

5

Input Specifications and Wiring Methods

In this chapter we tell the input specification and external wiring methods of XC series PLC. The connection method differs according to different model; the main reason is the terminal's position. For each model's terminal arrangement, please refer to chapter 2-3;

5-1 . Input Specification

5-2 . DC Input Signal (AC power supply type)

5-3 . High Speed counter input

5-1 . Input Specification

1 Basic Units

Input signal's voltage	DC24V \pm 10%
Input signal's current	7mA/DC24V
Input ON current	Up to 4.5mA
Input OFF current	Low than 1.5mA
Input response time	About 10ms
Input signal's format	Contact input or NPN open collector transistor
Circuit insulation	Photo-electricity coupling insulation
Input action's display	LED light when input ON

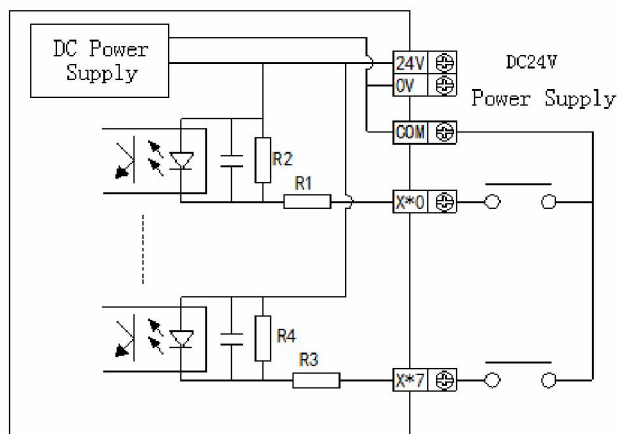

2 Expansion Modules

Input signal's voltage	DC24V \pm 10%
Input signal's current	7mA/DC24V
Input ON current	Up to 4.5mA
Input OFF current	Low than 1.5mA
Input response time	About 10ms
Input signal's format	Contact input or NPN open collector transistor
Circuit insulation	Photo-electricity coupling insulation
Input action's display	LED light when input ON

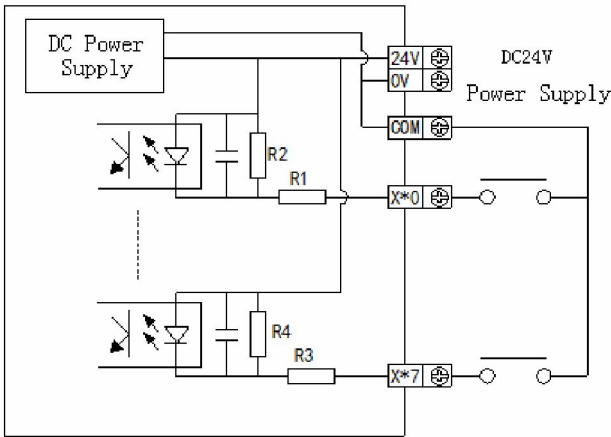

5-2 . DC Input Signal (AC Power Supply Type)

1	DC Input Signal
----------	----------------------------

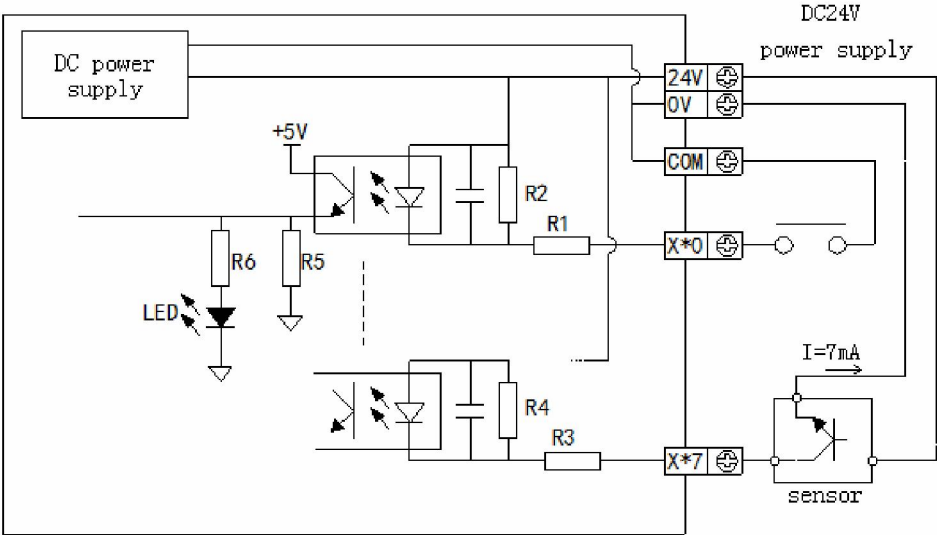

- l Input terminal
When connect input terminal and **COM** terminal with contacts without voltage or NPN open collector transistor, if input is ON , LED lamp lights, which indicates input. There are many **COM** terminals to connect in PLC.
- l Input circuit
Use optical coupling instrument to insulate the input once circuit and twice circuit , There's a C-R filter in the twice circuit. It is set to avoid wrong operation caused by vibration of input contacts or noise along with input signal. As the preceding reason, for the changing of input ON OFF , OFF ON , in PLC, the response time delays about 10ms. There's a digital filter inside X000~X015. This kind of filter can vary from 0~15ms according to the special register (D8020).
- l Input sensitive
The PLC's input current is DC24V 7mA , but to be safe , it needs current up to 3.5mA when it's ON , lower than 1.5mA when it's OFF.

2

External circuit used by sensors

XC series PLC's input power is supplied by its interior 24V power , so if use exterior power to drive photoelectricity sensor etc., , this exterior power should be $DC24V \pm 4V$, please use NPN open collector type for sensor's output transistor

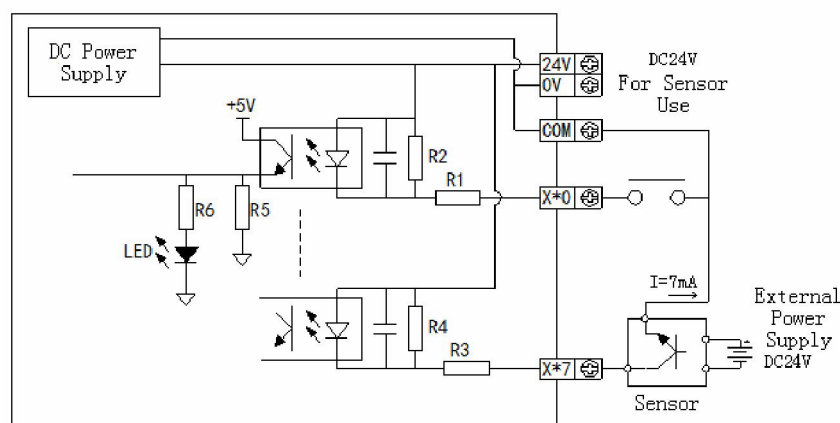

3

Input Wiring

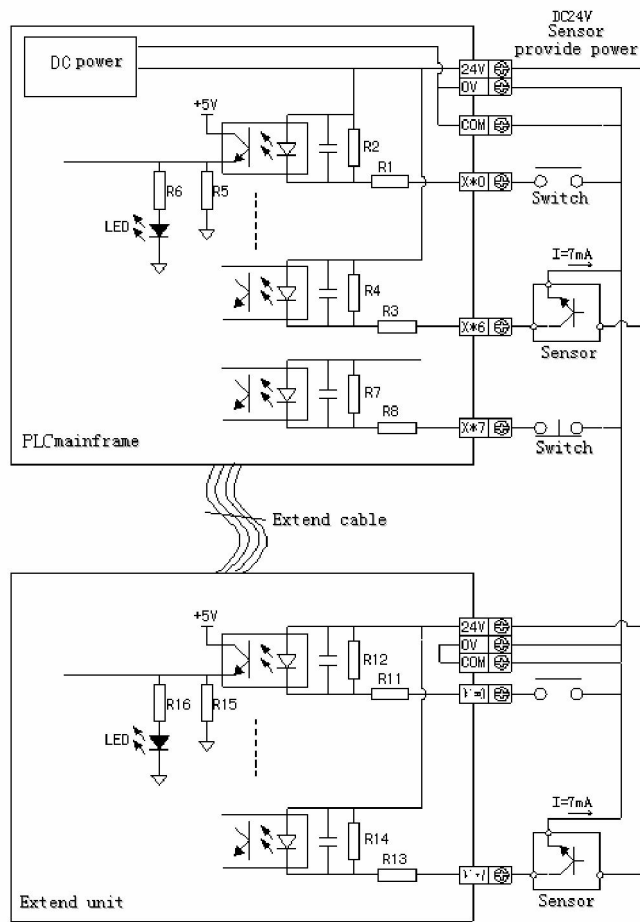

5-3 . High Speed Counter Input

XC series PLC support high speed count function which is independent with the scan cycle. Via choosing different counter, testing the high speed input signal comes from sensor and rotary encoder. The highest testing frequency can reach 80KHz.

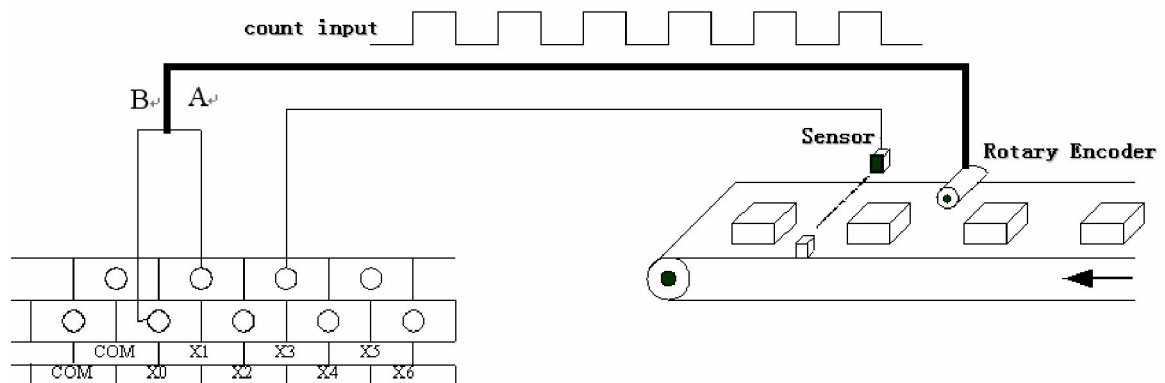

5-3-1 . Count Mode

XC series HSC function has three count modes: Increment mode, Pulse+Direction mode, AB-phase mode;

1 Increment Mode

Under this mode, input the pulse signal, the count value increase with every rising edge of pulse signal;

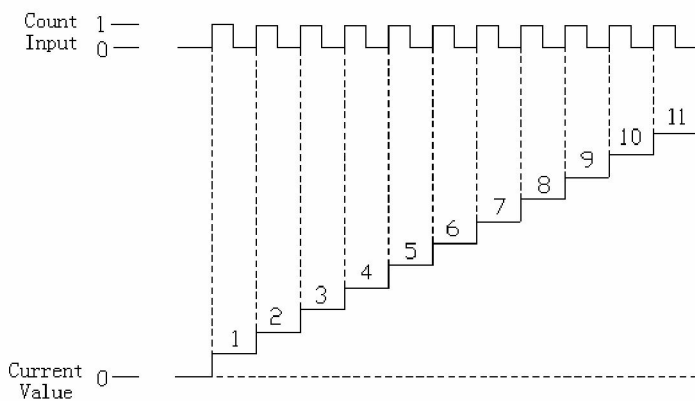

2 Pulse+Direction Mode

Under this mode, input the pulse signal and direction signal together. The count value increase or decrease according to the direction status. If the count direction is OFF, do increment count with the input's rising edge; If the count direction is ON, do decrement count with the input's rising edge;

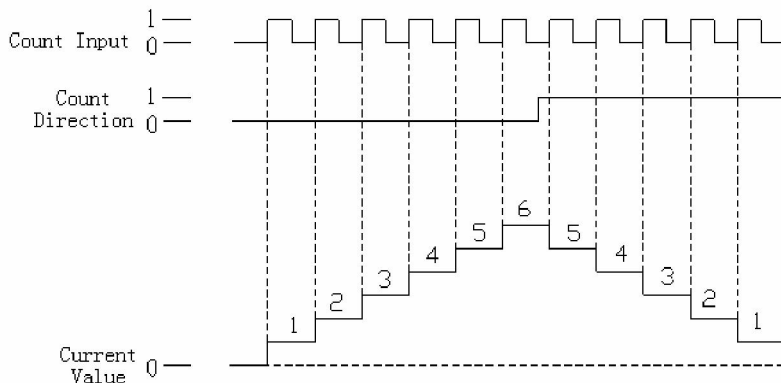

3 AB Phase Mode

Under this mode, the HSC value increase or decrease according to the two difference signal (A phase or B phase). According to the times number, we have also one-time frequency mode and four-time frequency mode. The default mode is four-time frequency mode.

One-time Frequency Mode

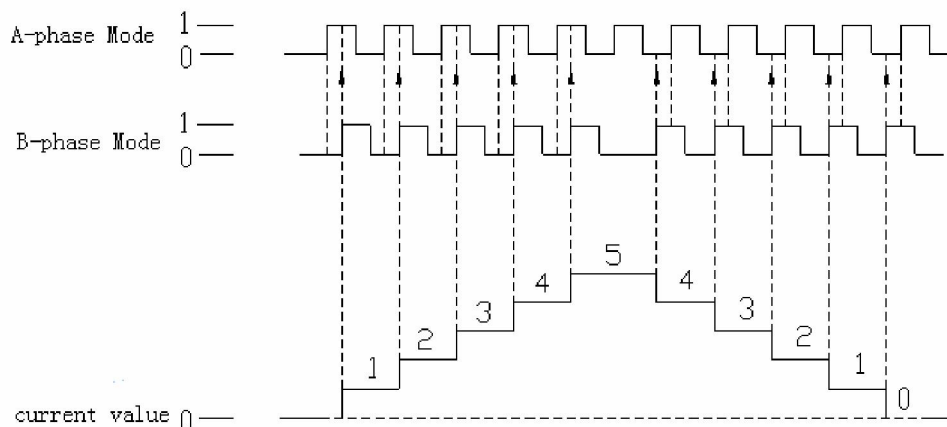

Four-time Frequency Mode

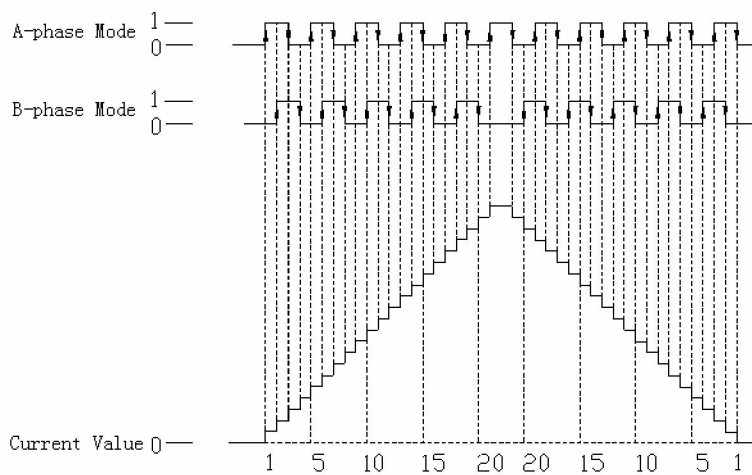

5-3-2 . High Speed Count Range

The HSC's count range is: $K-2,147,483,648 \sim K+2,147,483,647$. If the count value exceeds this range, up-flow or down-flow appears;

The up-flow means: the count value jumps from $K+2,147,483,647$ to be $K-2,147,483,648$, then continue to count; The down-flow means: the count value jumps from $K-2,147,483,648$ to be $K+2,147,483,647$, then continue to count;

5-3-3 . The Input Wiring Of HSC

For the input wiring of pulse, it differs according to PLC's model and counter's model. Below, we show several typical wiring method (take XC3-48 PLC as the example):

1 Increment Mode

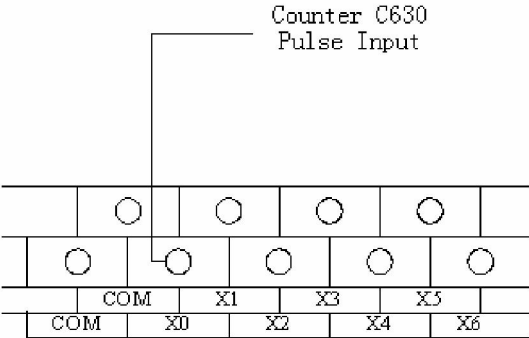

2 Pulse+Direction Mode

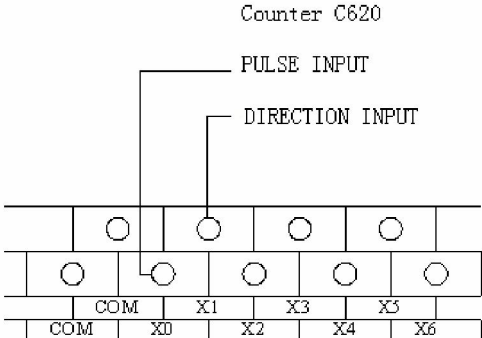

3 AB Phase Mode

X000	U										U					A		
X001		U									Dir					B		
X002																		
X003			U									U				A		
X004												Dir				B		
X005																		
X006				U														
X007					U													
X010																		
X011																		
X012																		

XC3 -14 PLC																		
	Increment Mode										Pulse + direction mode				AB phase mode			
	C600	C602	C604	C606	C608	C610	C612	C614	C616	C618	C620	C622	C624	C626	C628	C630	C632	C634
*Max. Frequency	10K	10K	10K	10K							10K	10K				5K	5K	
4 times frequency																		
Counter's interruption																		
X000	U										U					A		
X001											Dir					B		
X002		U																
X003			U															
X004												Dir					A	
X005				U								U					B	

* C600、 C620、 C630 can be 80KHz with customer's special requirements

XC3-19AR-E																		
	Increment Mode										Pulse + direction mode				AB phase mode			
	C600	C602	C604	C606	C608	C610	C612	C614	C616	C618	C620	C622	C624	C626	C628	C630	C632	C634
Max. Freq.	10K	10K	10K	10K							10K	10K				5K	5K	
4-time Freq.																		
Count Interrupt																		
X000	U										U					A		
X001											Dir					B		
X002		U										U					A	

XC5-24/32 PLC、XCM-24/32 PLC																		
	Increment Mode										Pulse + direction mode				AB phase mode			
	C600	C602	C604	C606	C608	C610	C612	C614	C616	C618	C620	C622	C624	C626	C628	C630	C632	C634
Max. Freq.	80K	10K									80K					80K		
4-time Freq.																		
Count Interrupt																		
X000	U										U					A		
X001											Dir					B		
X002																		
X003		U																
X004																		
X005																		
X006																		

5-3-4 . AB Phase Counter's Frequency Multiplication Setting

To AB phase counter, user can modify the value in FLASH data registers FD8241, FD8242, FD8243 to set the frequency multiplication value. When the value is 1, it is 1 time frequency; when the value is 4, it is 4 times frequency.

Register	Function	Setting Value	Content
FD8241	Frequency Multiplication of C630	1	1 time frequency
		4	4 time frequency
FD8242	Frequency Multiplication of C632	1	1 time frequency
		4	4 time frequency
FD8243	Frequency Multiplication of C634	1	1 time frequency
		4	4 time frequency

1 : For more information about high speed counter, please refer to 《XC series PLC user manual [Instruction Part]》

2 : To some special model, only one axis can be set as one time frequency or 4 times frequency, the left two axis are separately one time frequency and 4 times frequency.

