

# 6

## Output Specification and Wiring Methods

---

In this chapter we tell the output specification and external wiring methods of XC series PLC. The connection method differs according to different model; the main reason is the terminal's position. For each model's terminal arrangement, please refer to chapter 2-3;

6-1 . Output Specifications

6-2 . Relay Output Type

6-3 . Transistor Output Type

## 6-1 . Output Specification

1

### Relay Output

Interior power		Below AC250V、 DC30V
Circuit insulation		Mechanism insulation
Action denote		LED indicate lamp
Max load	Resistant load	3A
	Induce load	80VA
	Lamp load	100W
Open circuit's leak current		-
Mini load		DC5V 2mA
Response time	OFF ON	10ms
	ON OFF	10ms

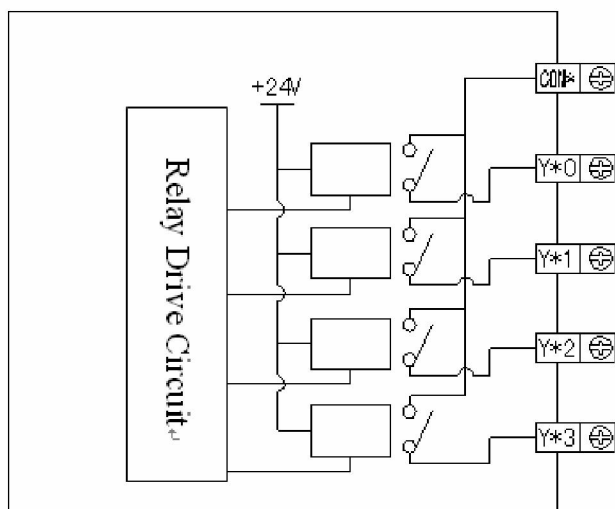

2	<b>Normal Transistor Output</b>
---	---------------------------------

Interior power		Below DC5~30V
Circuit insulation		Optical coupling insulation
Action denote		Indicate lamp LED
Max load	Restance load	0.8A
	Induce load	12W/DC24V
	Lamp load	1.5W/DC24V
Open circuit's leak current		-
Mini load		DC5V 2mA
Response time	OFF ON	Below 0.2ms
	ON OFF	Below 0.2ms

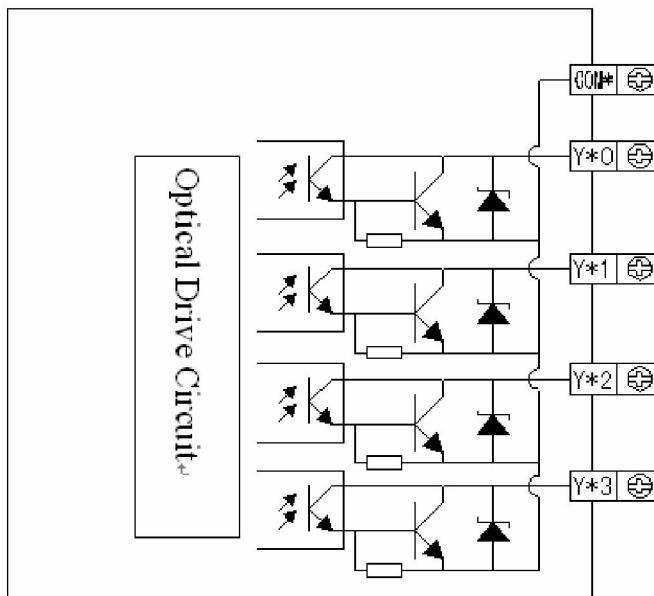

3

**High Speed Pulse Output**

Model	RT or T Type
High Speed Pulse Output Terminal	Common models are Y0、 Y1 ; XC5-24/32 model is Y0~Y3
External Power Supply	Below DC5~30V
Action Indication	LED Lamp
Maximum Current	50mA
Max output frequency of pulse	400KHZ

**6-2 . Relay Output Type**

1

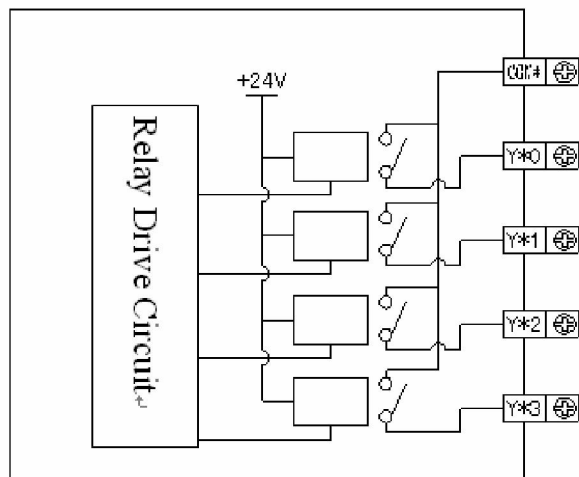
**Relay Output Circuit**

### 1 Output terminals

Relay output type includes 2~4 public terminals. So each public-end unit can drive different power-voltage system's (E.g. : AC200V , AC100V , DC24V etc.) load.

### 1 Circuit's insulation

Between the relay output coils and contacts , PLC's interior circuits and exterior circuits, load circuits are electric insulation. Besides, each public-end blocks are separate.

### 1 Action display

LED lamp lights when output relay's coils galvanize, output contacts are ON.

### 1 Response time

From the output relay galvanize (or cut) to the output contacts be ON (or OFF), the response time is about 10ms

### 1 Output current

The current-voltage below AC250V can drive the load of pure resistace 2A/1 point, inductance load below 80VA( AC100V or AC200V ) and lamp load below 100W ( AC100V or AC200V ) .

### 1 Open circuit's leak current

When the output contact be OFF and there's no leak current ,can directly drive Ne lamp etc.

### 1 The life of relay output contacts

Standard life of induce AC load such as contactor、 electromagnetism valve : 5 million times for 20VA load. Cut power device's life according to the company's test: for 80VA load, the action life is up to 2 million times. But if the load parallel connection with surge absorber, the life will be greatly improved!

## 2 Output Connection Example

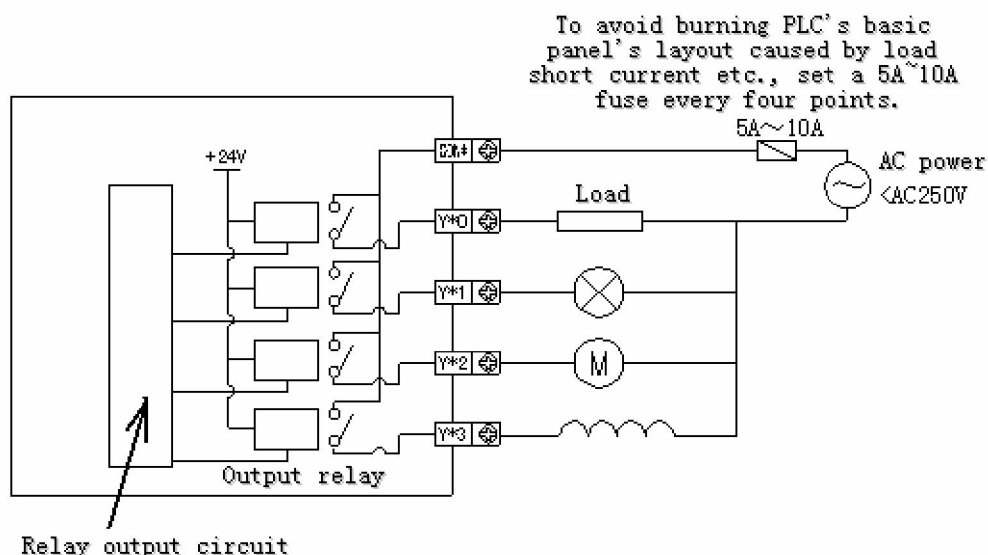

3

**Constitution of output circuit**

- | For DC induce load, please parallel connect with commutate diode. If not connect with the commutate diode, the contact's life will be decreased greatly. Please choose the commutate diode which allow inverse voltage endurance up to 5~10 times of the load's voltage, ordinal current exceeds load current.
- | Parallel connect AC induce load with surge absorber can reduce noise.

4

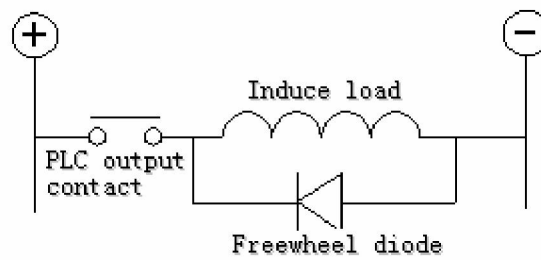
**DC Load**

5

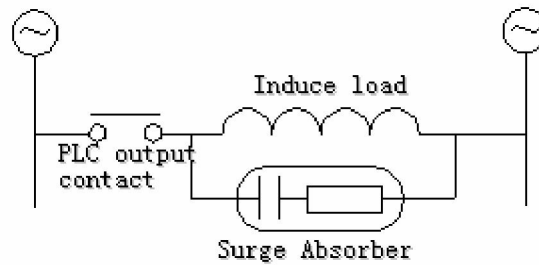
**AC Load**

### 6-3 . Transistor Output Type

Transistor output models support high speed pulse output and normal transistor these two types;

#### 1 Normal Transistor Output

##### Output Terminals

There are 1~4 COM outputs on transistor output type CPU units

##### External Power Supply

Please use DC5~30V this stable power supply to drive the load drive.

##### Circuit Isolation

Inside PLC, we use optical couples to isolate the internal circuit with the output transistors; besides, public blocks isolate to each other.

##### Action Indication

When driving optical couples, LED will be ON, the output transistors will be ON;

##### Response Time

From optical couple being ON (or OFF) to transistor being ON (or OFF), PLC needs time below 0.2ms.

##### Output current

Each output's current is 0.5A. But limited by the temperature rising, every 4 points' total current should be below 0.8A.

##### Open circuit current

Below 0.1mA

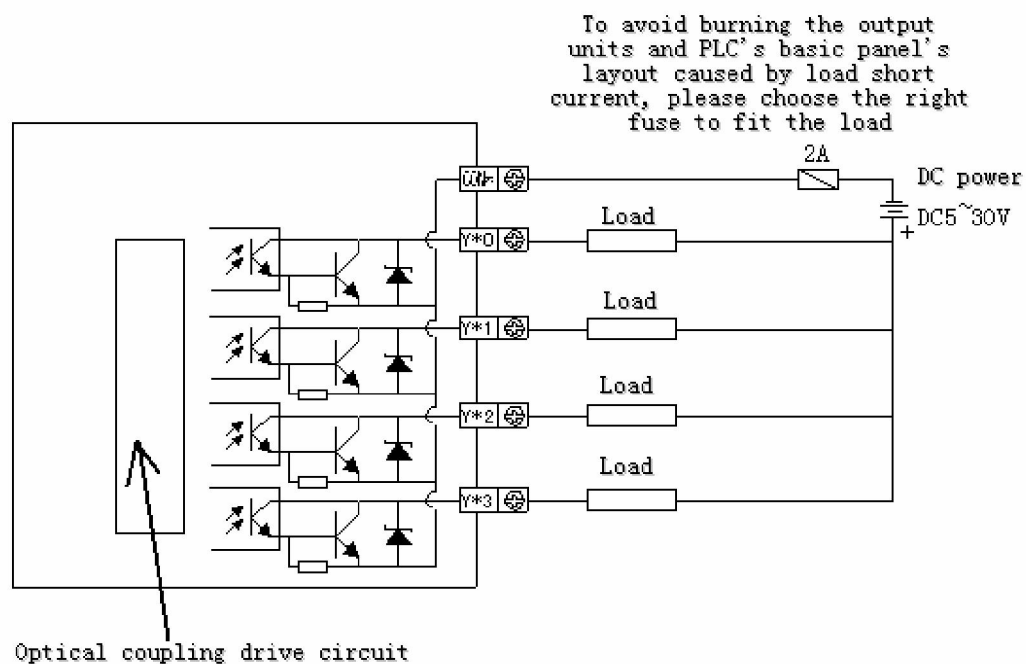

E.g.: Below is the connection diagram of RT/T type PLC with stepping driver:

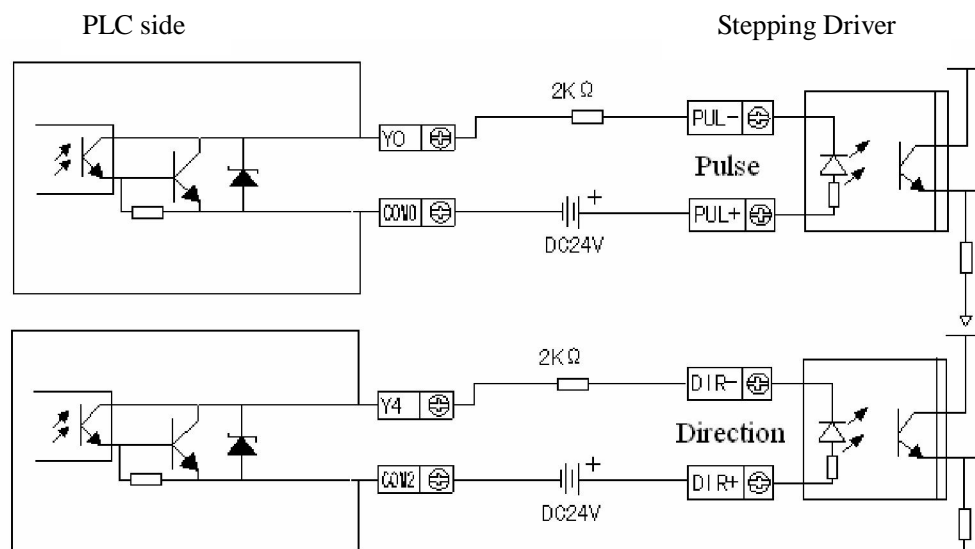

(Make sure the driver's optical couple's input terminal has 8~15mA reliable current)

