

8 Expansion Devices

XC series PLC expansions include expansion modules and expansion BD cards. The expansion modules include input/output expansion module, analogue, temperature expansion modules; BD cards include analogue temperature, communication applications etc. Via the expansion devices, XC series PLC are used widely in temperature, flow, liquid, pressure fields etc.

8-1 . Module's Summary

8-2 . Input/output modules

8-3 . Analogue Temperature Modules

8-4 . Expansion BD cards

8-1 . MODULES SUMMARY

1 General Specifications

Item	Content
Using environment	noncorrosive gas
Environmental Temperature	0 ~60
Stock temperature	-20~70
Environmental Humidity	5~95%
Stock Humidity	5~95%
Installation	Use M3 screws to fix or install on DIN46277 (width 35mm) DIN

2 Module's Structure

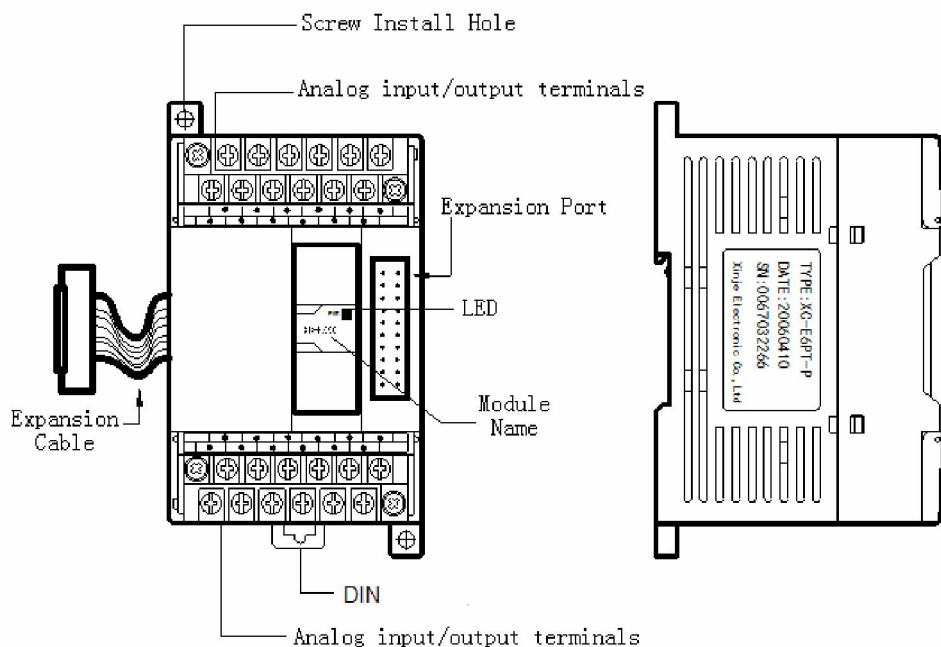

Name	Function
Power Supply Indication	The LED is ON when power on the module
Module Name	The model name of this special module
Expansion Port	Link with other expansion module
Analogue input/output	Used to connect with analogue input/output and peripheral

terminal	equipments, can be removed
DIN guild rail	Used to install the module directly
Screws install hole	Put M3 screw in the hole to finish installation
Expansion Cable	Realize data transfer by linking this cable to withPLC extension port

3 External Dimension

Graph 1 (Unit: mm)

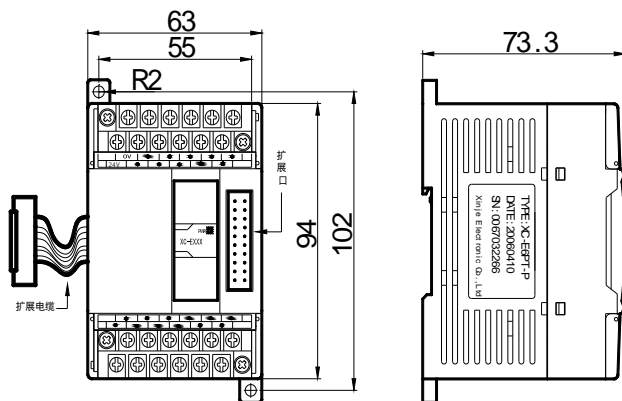

Suitable Models

Module Type	Model
Digital Input/output	8I/O、16I/O
Analogue	All
Temperature	All
Mixture	All

Graph 2 (Unit: mm)

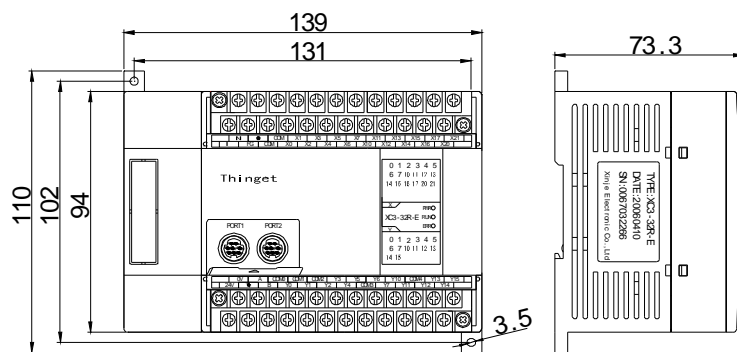

Suitable Models

Module Type	Model
Digital Input/output	32I/O
Analogue	None
Temperature	None
Mixture	None

4 Module Configuration

XC series modules can be installed on the right of XC-PLC main units:

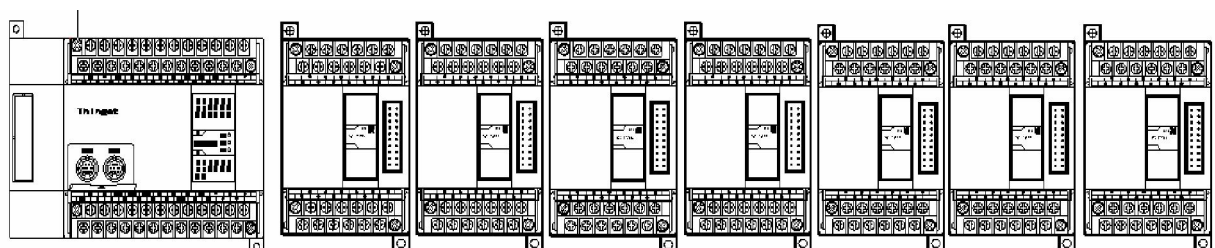

- | Digital input/output quantity is in octal form;
- | Input/output analog is in decimal form
- | PLC main units can work with 7 expansions and one extra BD card. The expansion module can be any type (analog or digital, temperature);

8-2 . Digital Input/output Modules

Input/output expansions, I/O ranges 8~32、 Input type、 output type、 input/output type、 transistor output、 relay output etc;

1 Model List

The detailed models are listed below:

	Model			I/O Nr.	Input Nr. (DC24V)	Output Nr. (R,T)
	Input	Output				
		Relay Output	Transistor Output			
N P N	XC-E8X	-	-	8	8	-
	-	XC-E8YR	XC-E8YT	8	-	8
	-	XC-E8X8YR	XC-E8X8YT	16	8	8
	XC-E16X	-	-	16	16	-
	-	XC-E16YR	XC-E16YT	16	-	16
	-	XC-E16X16YR	XC-E16X16YT	32	16	16
	XC-E32X	-	-	32	32	-
	-	XC-E32YR	-	32	-	32
P N P	XC-E8PX	-	-	8	8	-
	-	XC-E8YR	XC-E8YT	8	-	8
	-	XC-E8PX8YR	XC-E8PX8YT	16	8	8
	XC-E16PX	-	-	16	16	-
	-	XC-E16YR	XC-E16YT	16	-	16
	-	XC-E16PX16YR	XC-E16PX16YT	32	16	16
	XC-E32PX	-	-	32	32	-
	-	XC-E32YR	-	32	-	32

2	Module Specification
----------	-----------------------------

Power Supply Specification

DC24V (32 I/O expansion is AC220V)

| Input Specification

Input Items	Content
Input signal's voltage	DC24V \pm 10%
Input signal's current	7mA/DC24V
Input ON current	Up to 4.5mA
Input OFF current	Low than 1.5mA
Input response time	About 10ms
Input signal's format	Contact input or NPN open collector transistor
Circuit insulation	Photo-electricity coupling insulation
Input action's display	LED light when input ON

| Relay output

Input Items	Content	
Internal power	Below AC250V、 DC30V	
Circuit insulation	Mechanism insulation	
Action denote	LED indicate lamp	
Max load	3A	3A
	80VA	80VA
	100W	100W
Open circuit's leak current	-	
Mini load	DC5V 2mA	10ms
Response time	10ms	10ms

| Transistor Output

Input Items	Content	
Internal power	Below DC5~30V	
Circuit insulation	Optical coupling insulation	
Action denote	Indicate lamp LED	
Max load	0.8A	0.8A
	12W/DC24V	12W/DC24V

	1.5W/DC24V	1.5W/DC24V
Open circuit's leak current	-	
Mini load	DC5V 2mA	DC5V 2mA
Response time	Below 0.2ms	Below 0.2ms

3 Terminal Arrangement

I XC-E8X

	24V	COM	X1	X3	X5	X7	
	0V	COM	X0	X2	X4	X6	

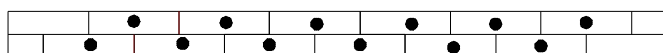

I XC-E8YR, XC-E8YT

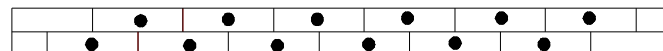

	Y0	Y1	Y2	COMB	Y5	Y7	
	COM0	COM1	COM2	Y3	Y4	Y6	

I XC-E8X8YR, XC-E8X8YT

	24V	COM	X1	X3	X5	X7	
	0V	COM	X0	X2	X4	X6	

	Y0	Y1	Y2	COMB	Y5	Y7	
	COM0	COM1	COM2	Y3	Y4	Y6	

I XC-E16X

	24V	COM	X1	X3	X5	X7	
	0V	COM	X0	X2	X4	X6	

	COM	X11	X13	X15	X17	●	
	COM	X10	X12	X14	X16	●	

I XC-E16YR, XC-E16YT

	Y0	Y1	Y2	COMB	Y5	Y7	
	COM0	COM1	COM2	Y3	Y4	Y6	

	Y10	Y11	Y12	COM7	Y15	Y17	
	COM4	COM5	COM6	Y13	Y14	Y16	

I XC-E32X

	N	●	COM	X1	X3	X5	X7	X11	X13	X15	X17	●	
	L	FG	COM	X0	X2	X4	X6	X10	X12	X14	X16	●	

	0V	●	COM	X21	X23	X25	X27	X31	X33	X35	X37	●	
	24V	●	COM	X20	X22	X24	X26	X30	X32	X34	X36	●	

I XC-E32YR, XC-E32YT

	N	•	Y0	Y2	COM1	Y5	Y7	Y20	Y22	COM3	Y25	Y27	
L	FG	COM0	Y1	Y3	Y4	Y6	COM2	Y21	Y23	Y24	Y26		

	0V	•	Y20	Y23	COM5	Y25	Y27	Y30	Y32	COM7	Y35	Y37	
24V	•	COM4	Y22	Y23	Y24	Y25	COM6	Y31	Y33	Y34	Y36		

I XC-E16X16YR

	N	•	COM	X1	X3	X5	X7	X11	X13	X15	X17	•	
L	FG	COM	X0	X2	X4	X6	X10	X12	X14	X16	•		

	0V	•	Y0	Y2	COM1	Y5	Y7	Y10	Y12	COM3	Y15	Y17	
24V	•	COM0	Y1	Y3	Y4	Y6	COM2	Y11	Y13	Y14	Y16		

8-3 . Analogue、 Temperature Modules

As the special modules of XC series PLC, analogue and temperature modules can work with XC series PLC, apply in process controls like temperature, pressure, flow etc.

For details, please refer to 《XC series analogue/temperature expansions manual》

The detailed modules are listed below:

Model	Function
XC-E8AD	8 channels analog input (14bit) ; 4 channels current input, 4 channels voltage input
XC-E4AD2DA	4 channels analog input (14bit); 2 channels analog output (12bit) ; current、 voltage selectable
XC-E4AD	4 channels analog input (14bit) ; current、 voltage selectable
XC-E4DA	4 channels analog output (12bit) ; current、 voltage selectable
XC-E2DA	2 channels analog output (12bit) ; current、 voltage selectable
XC-E6PT-P	-100 ~ 350 , 6 channels Pt100 temperature sampling, 0.1 degree precision, include PID operation
XC-E6TCA-P	0 ~ 1000 , 6 channels K type thermocouple temperature sampling module, 0.1 degree precision, include PID operation
XC-E3AD4PT2DA	3 channels current input (14bit), 4 channels Pt100 temperature sampling and 2 channels 10 bits voltage output
XC-E2AD2PT2DA	2 channels current input (14bit), 2 channels Pt100 temperature sampling (16bit), and 2 channels 10 bits voltage output

8-3-1 . XC-E8AD

1 Brief Introduction

- | 14 bits high precision analog input
- | 8 channels analog input : The first four channels voltage input (0~5V、0~10V two kinds) ; The left 4 channels current input (0~20mA、4~20 mA two kinds)
- | As special function module of XC, 7 models could be connected at most.
- | Support PID auto tune function

2 Specification

Items	Voltage input (0CH-3CH)	Current input (4CH-7CH)
Analog input bound	DC0 ~ 5V、 0 ~ 10V	DC0 ~ 20mA、 4 ~ 20mA
Max input bound	±18V	0 ~ 40mA
Digital output bound	14 bits binary data	
PID control value	0 ~ K4095	
Distinguish Ratio	1/16383 (14Bit)	
Integrate Precision	0.8%	
Convert speed	20ms/channel	
Power used by analog	DC24V±10% , 100mA	

3 Terminal Arrangement

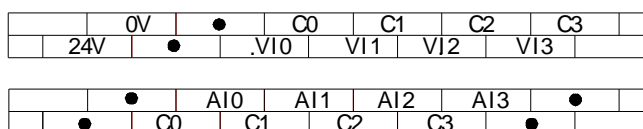

CH	NAME	SIGNAL	CH	NAME	SIGNAL
CH0	AI0	VI0+ voltage input	CH1	AI1	VI1+ voltage input
	C0	VI0- voltage input		C1	VI1- voltage input
CH2	AI2	VI2+ voltage input	CH3	AI3	VI3+ voltage input
	C2	VI2- voltage input		C3	VI3- voltage input
CH4	VI0	AI0+ current input	CH5	VI1	AI1+ current input
	C0	AI0- current input		C1	AI1- current input
CH6	VI2	AI2+ current input	CH7	VI3	AI3+ current input
	C2	AI2- current input		C3	AI3- current input

-	24V	+24V power supply
	0V	COM of power supply

8-3-2 . XC-E4AD2DA

1 Brief Introduction

- | 4CH analogue input: voltage and current input selectable; Voltage input range is 0 ~ 5V、0 ~ 10V selectable, current input range is 0 ~ 20mA、4 ~ 20mA selectable;
- | 2CH analogue output: voltage and current input selectable; Voltage input range is 0 ~ 5V、0 ~ 10V selectable, current input range is 0 ~ 20mA、4 ~ 20mA selectable;
- | 14 bits high precision analogue input;
- | As the special module, 7pcs XC-E4AD2DA can be connected to one XC series PLC main unit;

2 Specification

Items	Analogue Input		Analogue Output	
	Voltage Input	Current Input	Voltage output	Current Output
Analogue Input Range	0~5V,0~10V	0~20mA,4~20mA	-	
Max Input Range	DC±18V	0~40mA	-	
Analogue Output Range	-		0~5V、0~10V, (external load resistor 2K ~1M)	0~20mA,4~20mA (external load resistor 500)
Digital Input Range	-		12bits binary (0~4095)	
Digital Output Range	14 bits binary (0~16383)		-	
Distinguish Ratio	1/16383(14Bit); the convert data is stored in PLC in form of Hex. (14Bit)		1/4095(12Bit); the convert data is stored in PLC in form of Hex. (14Bit)	
PID Output Value	0~K4095			
Integral precision	0.8%			
Convert Speed	20ms/CH	3ms/CH		
Power Supply	DC24V±10%, 100mA			

3 Terminal Arrangement

	0V	●		C0	AO0		C1	AO1	
	24V	●	●	VO0	●	VO1			

	VI0	C1	A11	VI2	C3	A13	
	C0	AI0	VI1	C2	AI2	VI3	

CH	NAME	SIGNAL	CH	NAME	SIGNAL
CH0	AI0	Current analogue input	CH1	AI1	Current analogue input
	VI0	Voltage analogue input		VI1	Voltage analogue input
	C0	COM of CH0		C1	COM of CH1
CH2	AI2	Current analogue input	CH3	AI3	Current analogue input
	VI2	Voltage analogue input		VI3	Voltage analogue input
	C2	COM of CH2		C3	COM of CH3
CH0	AO0	Current analogue output	CH1	AO1	Current analogue output
	VO0	Voltage analogue output		VO1	Voltage analogue output
	C0	COM of CH0		C1	COM of CH1
-	24V	+24V power supply			
	0V	COM of power supply			

8-3-3 . XC-E4AD

1 Brief Introduction

- | 4CH analogue input: voltage and current input selectable; Voltage input range is 0 ~ 5V、0 ~ 10V selectable, current input range is 0 ~ 20mA、4 ~ 20mA selectable;
- | 14 bits high precision analogue input;
- | As the special module, 7pcs XC-E4AD can be connected to one XC series PLC main unit;
- | XC-E4AD module support PID auto tune function;

2	Specification
---	----------------------

Items	Analogue Input (AD)	
	Voltage Input	Current Input
Analogue Input Range	DC0 ~ 5V、0 ~ 10V	DC0 ~ 20mA、4 ~ 20mA
Max Input Range	DC±18V	DC0 ~ 40mA
Analogue Output	-	
Digital Input Range	-	
Digital Output Range	14 bits binary (0 ~ 16383)	
Distinguish Ratio	1/16383(14Bit); the convert data is stored in PLC in form of Hex. (14Bit)	
PID Output Value	0 ~ K4095	
Integral precision	0.8%	
Convert Speed	20ms/CH	
Power Supply	DC24V±10% , 100mA	

3	Terminal Arrangement
---	-----------------------------

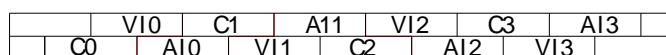
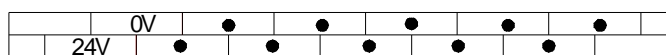

CH	NAME	SIGNAL	CH	NAME	SIGNAL
CH0	AI0	Current analogue input	CH1	AI1	Current analogue input
	VI0	Voltage analogue input		VI1	Voltage analogue input
	C0	COM of CH0		C1	COM of CH1
CH2	AI2	Current analogue input	CH3	AI3	Current analogue input
	VI2	Voltage analogue input		VI3	Voltage analogue input
	C2	COM of CH2		C3	COM of CH3
-	24V	+24V power supply			
	0V	COM of power supply			

8-3-4 . XC-E4DA

1	Brief Introduction
---	---------------------------

- l 4CH analogue output: voltage and current input selectable; Voltage input range is 0 ~ 5V, 0 ~ 10V selectable, current input range is 0 ~ 20mA, 4 ~ 20mA selectable;
- l 10 bits high precision analogue output;
- l As the special module, 7pcs XC-E4DA can be connected to one XC series PLC main unit;

2	Specification
---	----------------------

Items	Voltage Output	Current Output
Analogue Output Range	DC0 ~ 5V、0 ~ 10V (external load resistor 2K ~ 1M)	DC0 ~ 20mA、4 ~ 20mA (external load resistor less than 500)
Digital Input Range	12 bits binary	
Distinguish Ratio	1/1023(10Bit); the convert data is stored in PLC in form of Hex. (12Bit)	
Integral Precision	0.8%	
Convert Speed	3ms/CH	
Power Supply	DC24V±10% , 100mA	

3	Terminal
---	-----------------

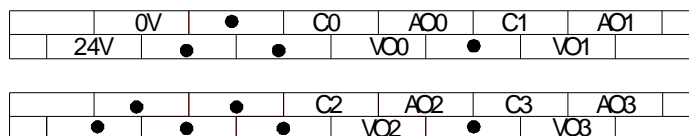

CH	NAME	SIGNAL	CH	NAME	SIGNAL
CH0	AO0	Current analogue output	CH1	AO1	Current analogue output
	VO0	Voltage analogue output		VO1	Voltage analogue output
	C0	COM of CH0		C1	COM of CH1
CH2	AO2	Current analogue output	CH3	AO3	Current analogue output
	VO2	Voltage analogue output		VO3	Voltage analogue output
	C2	COM of CH2		C3	COM of CH3
	24V	+24V power supply			

	0V	COM of power supply
--	----	---------------------

8-3-5 . XC-E2DA

1 Brief Introduction

- | 2CH analogue output: voltage and current input selectable; Voltage input range is 0 ~ 5V、0 ~ 10V selectable, current input range is 0 ~ 20mA、 4 ~ 20mA selectable;
- | 12 bits high precision analogue input;
- | As the special module, 7pcs XC-E2DA can be connected to one XC series PLC main unit;

2 Specification

Items	Voltage Output	Current Output
Analogue Output Range	DC0 ~ 5V、 0 ~ 10V	DC0 ~ 20mA、 4 ~ 20mA
	External Load Resistor (2K ~ 1M)	External Load Resistor less than 500
Digital Input Range	12 bits binary	
Distinguish Ratio	1/4096(12Bit); the convert data is stored in PLC in form of Hex. (12Bit)	
Integral Precision	0.8%	
Convert Speed	3ms/CH	
Power Supply	DC24V±10% , 100mA	

3 Terminal Arrangement

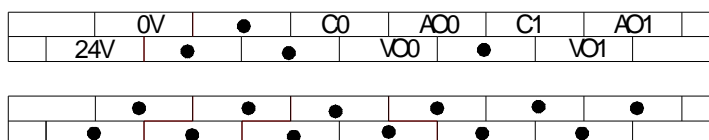

CH	NAME	SIGNAL
CH0	A00	Current analogue output
	VO0	Voltage analogue output
	C0	COM of CH0

CH1	AO1	Current analogue output
	VO1	Voltage analogue output
	C1	COM of CH1
-	24V	+24V power supply
	0V	COM of power supply

8-3-6 . XC-E6PT-P

1 Brief Introduction

- | Pt resistor input, the scale is Pt100
- | 6CH input, 6CH output, 2 groups PID parameters (3CH/group)
- | 1mA constant output, doesn't effected by the environment;
- | The distinguish precision is 0.1
- | As the special module, 7pcs XC-E6PT-P can be connected to one XC series PLC main unit;

2 Specification

Items	Content
Analogue Input Signal	Pt100 resistor
Temperature testing range	-100 ~ 350
Digital Output range	-1000 ~ 3500, 16bits with sign, binary
Control precision	±0.5
Distinguish Ratio	0.1
Integral Precision	0.8% (Relate to the max value)
Convert Speed	20ms/CH
Power Supply	DC24V±10% , 50mA

1: If no signal input, the value is 3500;

2: According to the actual requirements, connect with Pt100 resistors

3 Terminal Arrangement

	0V	COM0	COM1	COM2	Y3	Y5	
24V	●	Y0	Y1	Y2	Y4		
	A0	A1	A2	A3	A4	A5	
C0	C1	C2	C3	C4	C5		

CH	NAME	SIGNAL	CH	NAME	SIGNAL
CH0	A0	0CH thermo-resistor input terminal	CH1	A1	1CH thermo-resistor input terminal
	C0	0CH COM of thermo-resistor input		C1	1CH COM of thermo-resistor input
CH2	A2	2CH thermo-resistor input terminal	CH3	A3	3CH thermo-resistor input terminal
	C2	2CH COM of thermo-resistor input		C3	3CH COM of thermo-resistor input
CH4	A4	4CH thermo-resistor input terminal	CH5	A5	5CH thermo-resistor input terminal
	C4	4CH COM of thermo-resistor input		C5	5CH COM of thermo-resistor input
	Y0	Output of CH0		Y1	Output of CH1
	Y2	Output of CH2		Y3	Output of CH3
	Y4	Output of CH4		Y5	Output of CH5
-	24V	+24V power supply			
	0V	COM for power supply			
COM0、COM1、COM2: COM for outputs					

8-3-7 . XC-E6TCA-P

1 Brief Introduction

Support many thermocouple types (K, S, E, N, J, T, R types)

Adopt DC-DC power supply isolate design, enhance the anti-interfere ability;

The temperature precision is 0.1 °C.

Set each channel's PID parameters independently, equipped with separate register space;

Support real time PID auto tune function; enable the device to PID auto tune under every status (cold status, heating status, transition status etc), get the best PID values;

Realize data exchange with FROM and TO instructions, enhance the flexibility, reduce the data exchange quantity, expand the data memory space;

2 Specification

Items	Specifications
Analogue Input Signal	K、S、E、N、J、T、R type thermocouples
Temperature testing range	0 ~ 1000
Digital Output range	0 ~ 4095, without sign 12 bits, decimal
Control precision	0.1
Distinguish Ratio	0.1
Integral Precision	0.1
Convert Speed	20ms/CH
Power Supply	DC24V±10% , 50mA

1: When no signal input, the channel's data is 4095;

2: According to the actual requirements, connect with the thermo-resistors;

3 Terminal Arrangement

	0V	COM0	COM1	COM2	Y3	Y5	
24V	●	Y0	Y1	Y2	Y4		
	TC0+	TC1+	TC2+	TC3+	TC4+	TC5+	
	TC0-	TC1-	TC2-	TC3-	TC4-	TC5-	

CH	NAME	SIGNAL	CH	NAME	SIGNAL
CH0	TC0+	CH0 temperature input +	CH1	TC1+	CH1 temperature input +
	TC0-	CH0 temperature input -		TC1-	CH1 temperature input -
CH2	TC2+	CH2 temperature input +	CH3	TC3+	CH3 temperature input +
	TC2-	CH2 temperature input -		TC3-	CH3 temperature input -
CH4	TC4+	CH4 temperature input +	CH5	TC5+	CH5 temperature input +
	TC4-	CH4 temperature input -		TC5-	CH5 temperature input -
Y0~Y5		Output Channel Y0 ~ Y5 Analogue Output: in the form of digital type, the range is 0~4095 Digital Output: in the form of occupy ratio, Y output in the activate time			
-	24V	+24V power supply			
	0V	COM of power supply			

8-3-8 . XC-E3AD4PT2DA

1 Brief Introduction

- | 3CH 14bits current input、 4CH PT100 temperature input and 2CH 10bits voltage output
- | 3CH AD is current (0~20mA、 4~20mA) selectable; 2Ch DA is voltage (0~5V、 0~10V) selectable, choose via the software;
- | Pt resistor input, the scale is PT100
- | 3CH A/D and 4CH PT input are equipped with PID auto tune function;
- | As the special module, 7pcs XC-E3AD4PT2DA can be connected to one XC series PLC main unit;

2 Specification

Items	Analogue Current Input (AD)	Temperature Input (PT)	Analogue Voltage Output (DA)
Analogue input	DC0 ~ 20mA、 4 ~ 20mA	PT100	-
Temperature testing range	-	-100~350	-
Max input range	DC0 ~ 40mA	-	-
Analogue output range	-	-	DC0~5V、 0~10V(external load resistor 2K ~1M)
Digital input range	-	-	10 bits Binary (0~1023)
Digital Output Range	14 bits Binary (0~16383)	-1000~3500	-
Distinguish Ratio	1/16383(14Bit): The converted data is stored in PLC in Hex. (14Bit)	0.1	1/1023(10Bit): The converted data is stored in PLC in Hex. (10Bit)
PID Output Value	0~K4095		-
Integral Precision	0.8%	±0.5	0.8%
Convert Speed	20ms/CH		3ms/CH
Power Supply	DC24V±10% , 100mA		

3 Terminal Arrangement

	0V	AI0	AI1	AI2	VO0	VO1	
24V	C0	C1	C2	C3	C4		

	B0	A1	C1	B2	A3	C3	
A0	C0	B1	A2	C2	B3		

CH	NAME	SIGNAL	CH	NAME	SIGNAL
0CH	AI0	0CH current Input	1CH	AI1	1CH current Input
	C0	0CH current Input COM		C1	1CH current Input COM
2CH	AI2	2CH current Input			
	C2	2CH current Input COM			
0CH	A0	0CH temperature input	1CH	A1	1CH temperature input
	B0	-		B1	-
	C0	0CH input COM		C1	1CH input COM
2CH	A2	2CH temperature input	3CH	A3	3CH temperature input
	B2	-		B3	-
	C2	2CH input COM		C3	3CH input COM
0CH	VO0	0CH voltage output	1CH	VO1	1CH voltage output
	C3	0CH voltage output COM		C4	1CH voltage output COM
-	24V	+24V power supply			
	0V	power supply COM			

8-3-9 . XC-E2AD2PT2DA

1 Brief Introduction

2CH 16bits analogue input、 2CH PT100 temperature input and 2CH 10bits analogue output
2CH input/output is current, voltage selectable (current: 0~20mA、 4~20mA; voltage: 0~5V、
0~10V), select via XCPPro;

2CH A/D and 2CH PT input has PID auto tune function;

Adopt DC-DC power supply isolation design, enhance the anti-interfere ability;

The display precision is 0.01

Set each channel's PID value separately, equipped separate register space;

Support real time PID auto tune function; enable the device to PID auto tune under every
status (cold status, heating status, transition status etc), get the best PID values;

Realize data exchange with FROM and TO instructions, enhance the flexibility, reduce the
data exchange quantity, expand the data memory space;

2	Specification
---	----------------------

Items	Analogue Input (AD)		Temp. input (PT)	Analogue output (DA)	
Analogue Input	Current	0 ~ 20mA 4 ~ 20mA	PT100	-	
	Voltage	0 ~ 5V 0 ~ 10V			
Temperature Range	-		-100~350	-	
Max input range	DC0 ~ 40mA		-	-	
Analogue output range	-		-	Current	0 ~ 10V 0 ~ 5V
				Voltage	0 ~ 20mA 4 ~ 20mA
Digital input range	-		-	10 bits binary (0~1023)	
Digital Output range	16 bits binary (0~65535)		-1000~3500	-	
Distinguish Ratio	1/16383(16Bit)		0.01	1/1023(10Bit)	
PID Output value	0~K4095			-	
Integral precision	0.8%	±0.01		0.8%	
Convert speed	20ms/CH			3ms/CH	
Power supply	DC24V±10% , 100mA				

3 Terminal Arrangement

	0V	•	•	•	VO0	VO1	CO0	CO1
24V	•	•			IO0	IO1		
	PT0	VB	COM	AI0	VI1	CI1		
VA	COM	PT1	VI0	CI0	AI1			

Name	Terminals	Comments	
Input terminals	PT0, PT1	Temperature Input	Analogue input, PT100 temperature sensor (-100 ~ 350)
	VI0, VI1	Analogue Input	Voltage Input 0~10V or 0~5V
	AI0, AI1		Current input 0~20mA or 4~20mA
Output terminals	VO0, VO1	Analogue Output	Voltage Input in digital form, range: 0~1023
	IO0, IO1		Current input in digital form, range: 0~1023

Three-line PT100 resistor's input wiring is shown below:

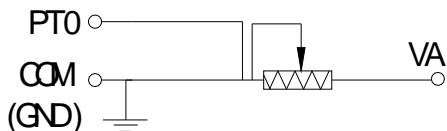

To normal PT100 resistors, wire according to the terminal's color; the terminal with same color can connect to PT1 and COM randomly, the other terminal connect to VA side;

8-4 . Expansion BD cards

1 Installatio

Open the cover on the left side (see the dotted line below), install the card according to the pin connectors and fix with screws; fix the protection cover to finish;

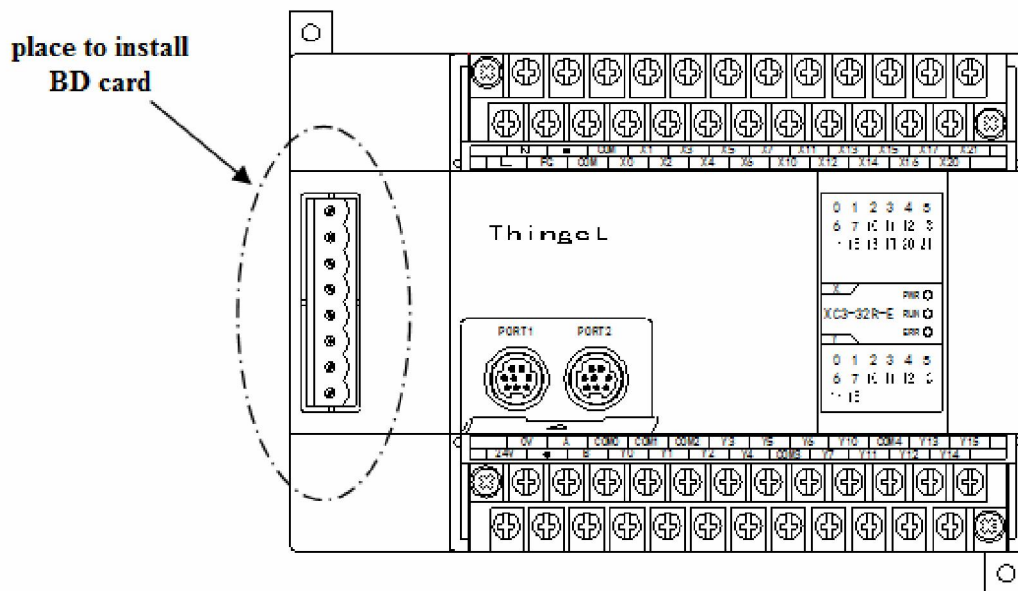

2 Configuration

- 1) Install the BD card on PLC correctly
- 2) Link PLC via XCPPro, in “Configure” menu, choose “BD settings ” (See graph below)

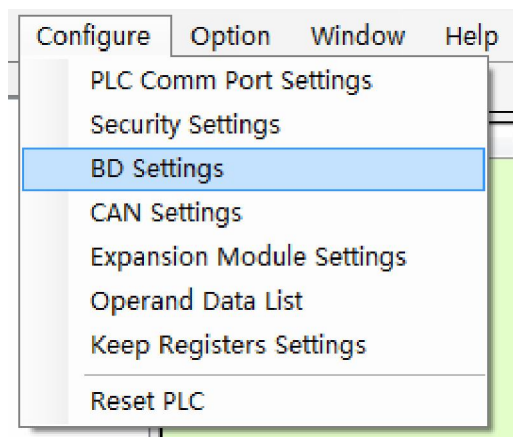

- 3) In “BD settings”, choose “Other BD”, then set BD from the right options; finally download the user program;

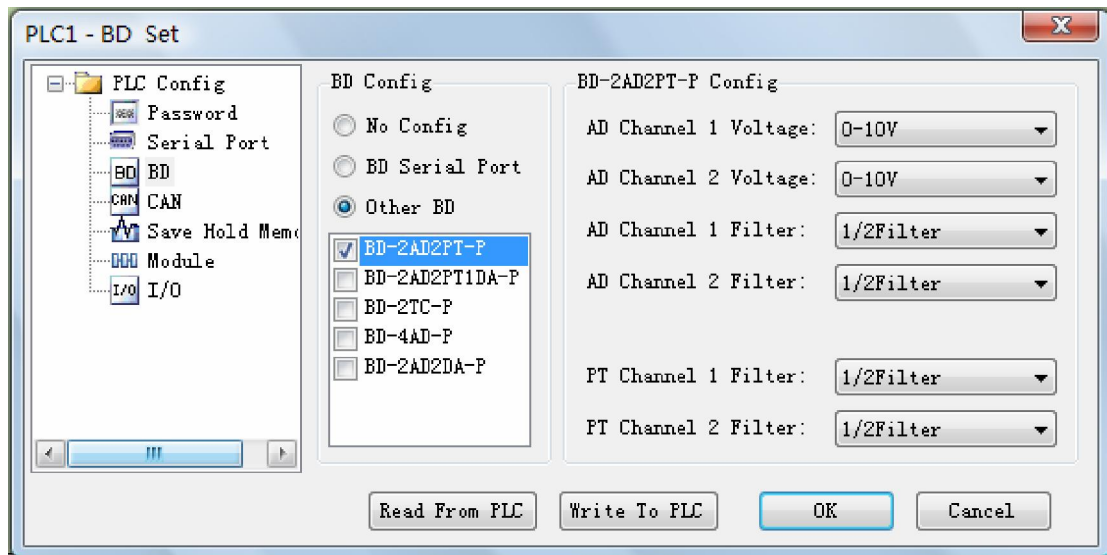

- 1: If configure XC-COM-BD, then “BD config” option should choose “BD Serial Port”

8-4-1 . XC-2AD2PT-BD

1 Specifications

- | 14 bits high precision analogue input
- | 2CH voltage 0~10V、 0~5V selectable; 2CH temperature input;
- | Pt temperature resistor sensor input (Pt100 2-line form)

2 Specification

Items	Voltage Input	Temperature Input
Analogue input signal	DC0~5V、 0~10V (the input resistor is 300k)	Pt resistor Pt100 (2-line)
Temperature testing range	-	-100~350
Distinguish	0.15mV (10/16383)	0.1
Digital output range	0~16383	-1000~3500
Integral precision	±0.8% of the full scale	
Convert time	15ms×4CH	
PID output value	0~K4095	
Default value	0	3500
Input Specialty		
Isolation	No isolation among PLC's each channel	
I/O occupation	0 I/O (as operate via data register, so I/O is not limited by PLC's standard I/O limitation) (

8-4-2 . XC-COM-BD

1

Specifications

- | For RS-485 communication
- | For RS-232 communication
- | RS-232 and RS-485 can't be used at the same time

2

Pins

