

THINGET

XC Series Programmable Controller

User Manual

Xinje Electronic Co., Ltd.

THINGET Xinje Electronic

	Preface	
	Catalog	
XC series	-----	
Programmable controller	Summary of XC series PLC	1
	➤ -----	
Operating manual	-----	
	Spec., Input/output and layout	2

	Function of each device	3

	Basic SFC instructions	4

	Applied instructions	5

	Special function	6

	Applied examples	7

	Appendix	8

This manual includes some basic precautions which you should follow to keep you safe and protect the products. These precautions are underlined with warning triangles in the manual. About other manuals that we do not mention, please follow basic electric operating rules.

Precautions



Please follow the precautions. If not, it may lead the control system incorrect or abnormal, even cause fortune lose.

**Correct
Application**



The models could only be used according to the manual, and an only be used along with the peripheral equipments recognized or recommended by Xinje Electronic. They could only work normally in the condition of be transported, kept and installed correctly, also please operate and maintain them according to the recommendation.

Xinje Electronic Co., Ltd. Copyright reserved

Without exact paper file allowance, copy, translate or using the manual is not allowed. Disobey this, people should take the responsibility of loss. We reserve all the right of expansions and their design patent.

Duty Declare

We have checked the manual, its content fits the hardware and software of the products. As mistakes are unavoidable, we couldn't promise all correct. However, we would check the data in the manual frequently, and in the next edition, we will correct the necessary information. Your recommendation would be highly appreciated

Preface

——Specialties of programmable controller

The programming of XC series programmable controller has the following characteristic:

- **Support two kinds of program languages**
In XC series PLC, besides statement format, you can also adopt ladder chart on the screen. And, these two formats could convert to the other.
- **Rich basic functions**
Based on the theory of "Basic functions, High speed dispose, convenient to use", XC series PLC can support not only functions relative to sequence control, but also basic application instructions of data transfer and compare, arithmetic and logic control, loop and shift of data etc., besides, it can support interrupt, high-speed counter exclusive compare instructions, high-speed impulse output and other high-speed dispose instructions.
- **Offset function (Indirect addressing)**
Add offset suffix after the coil, data register (e.g. X3[D100], D0[D100]) to realize indirect addressing. E.g. when D100=0, X3[D100] means X3, D0[D100] means D0; when D100=9, X3[D100] means X14, D0[D100] means D9;
- **Single phase or AB high speed counter**
The high speed counters in XC series PLC carry on interrupt disposal with the high speed pulse from special input points. So it is independent with the scan cycle, the count speed can reach 200KHz.
- **Convenient MODBUS communication instructions**
With Modbus communication instruction, PLC can easily communicate with every kind of peripheral device as long as they have Modbus protocol.
- **High speed pulse output**
The main units have two routes pulse output, output can be sequential segments, each segment of pulse number could be set freely. The pulse could reach 400KHz.

XC series PLC are divided into XC1、XC3、XC5 these three sub-series:

XC1 economic type: This sub-series has specifications of 16 I/O、24 I/O、32 I/O. The function is simple, suitable for common, small scale applications. They don't support high speed count, pulse output, free communication these advanced functions, also they can not connected with the expansions. For the details, please refer to the appendix 8-3 "XC1 using description".

XC3 Standard type: This sub-series belongs to the standard models of XC series PLC. They could fulfill most using requirements. If no special demonstrate, this manual's content are all written for XC3 series PLC.

XC5 strength type: This sub-series has specifications of 32 I/O、48 I/O、60 I/O . Besides the functions of XC3-PLC, XC5-32 has function of 4 channels pulse output, XC5-48, XC5-60 support CANBUS instructions, they can realize CAN bus network function. For the details, please refer to the appendix 8-4 "XC5 using description"

Memo

1. Summary of XC series PLC

XC series PLC are mini type PLC with powerful function. This series products can satisfy diverse control requirement. With compact design, excellent extend capability, cheap price and powerful function, XC series PLC has become perfect solution of small size control.

1-1. Summary of XC series PLC and program format

1-2. XC series PLC's model and type

1-3. Expansion's constitution and ID assignment

1-4. General specification

1-5. Shape and Size

1-6. Terminal arrangement

1-7. Communication ports' definition

1-1. Summary of XC series PLC and program format

Introduction

XC series programmable controller

- I/O 14~60 points
- FlashROM memory inside
- Real time clock: With clock inside, Li battery power drop memory
- Multi-COM ports, can connect with inverters、 instruments、 printers etc.
- Rich instructions, convenient to program

Program

Format

《Statement Program》

Statement program is the format which use "LD" "AND" "OUT" etc. these SFC instructions to input. This format is the basic input form to compile the SFC program. But it's not convenient for understanding.

E.g:

Step	Instruction	ID
0	LD	X000
1	OR	Y005
2	ANI	X002
3	OUT	Y005

《Ladder Program》

Use sequential control signal and soft unit's ID to draw the sequential circuit's graph on the screen, which is called ladder program. As this method uses trigger point's symbols and coil symbols to denote the sequential control circuit, so it is easy to understand the program's contents. At the same time it's also available to monitor the PLC's action via the status displayed in the circuit.

E.g:

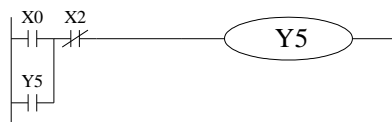

Alternation

The programs compiled with the preceding two methods are both stored in the PLC's program memory in the format of instruction table. So, the denotation and edition of this two program format can convert to the other.

1-2. XC series PLC's Model and Type

XC Series
Main Units

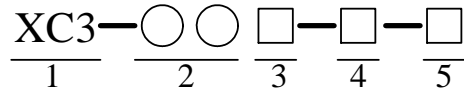

- 1: Series Name XC1 series、XC3 series、XC5 series、
- 2: I/O points
- 3: Input Format (NPN)R: Relay output
 - T: Transistor output
 - RT: Mix output of Transistor /Relay (Y0、Y1 are transistor)
- Output Format (PNP)PR: Relay output
 - PT: Transistor output
 - PRT: Mix output of Transistor /Relay (Y0、Y1 are transistor)
- 4: Supply Power E: AC Power (220V)
- C: DC Power (24V)
- 5: Clock S: With clock and RS485 COM port inside
- Vacant: Without clock and RS485 COM port inside

XC1 series models:

Model					Input (DC24V)	Output (R, T)
AC Power		DC Power				
Relay Output	Transistor Output	Relay Output	Transistor Output			
N P N Type	XC3-16R-E	XC3-16T-E	XC3-16R-C	XC3-16T-C	8 points	8 points
	XC3-24R-E	XC3-24T-E	XC3-24R-C	XC3-24T-C	12 points	12 points
	XC3-32R-E	XC3-32T-E	XC3-32R-C	XC3-32T-C	16 points	16 points
P N P Type	XC3-16PR-E	XC3-16PT-E	XC3-16PR-C	XC3-16PT-C	8 points	8 points
	XC3-24PR-E	XC3-24PT-E	XC3-24PR-C	XC3-24PT-C	12 points	12 points
	XC3-32PR-E	XC3-32PT-E	XC3-32PR-C	XC3-32PT-C	16 points	16 points

XC3 series models:

Model							Input (DC24V)	Output (R, T)
AC Power			DC Power					
Relay Output	Transistor Output	Mix output (R&T)	Relay Output	Transistor Output	Mix output (R&T)			
N P N Type	XC3-14R-E	XC3-14T-E	XC3-14RT-E	XC3-14R-C	XC3-14T-C	XC3-14RT-C	8 points	6 points
	XC3-24R-E	XC3-24T-E	XC3-24RT-E	XC3-24R-C	XC3-24T-C	XC3-24RT-C	14 points	10 points
	XC3-32R-E	XC3-32T-E	XC3-32RT-E	XC3-32R-C	XC3-32T-C	XC3-32RT-C	18 points	14 points
	XC3-48R-E	XC3-48T-E	XC3-48RT-E	XC3-48R-C	XC3-48T-C	XC3-48RT-C	28 points	20 points
	XC3-60R-E	XC3-60T-E	XC3-60RT-E	XC3-60R-C	XC3-60T-C	XC3-60RT-C	36 points	24 points
P N P Type	XC3-14PR-E	XC3-14PT-E	XC3-14PRT-E	XC3-14PR-C	XC3-14PT-C	XC3-14PRT-C	8 points	6 points
	XC3-24PR-E	XC3-24PT-E	XC3-24PRT-E	XC3-24PR-C	XC3-24PT-C	XC3-24PRT-C	14 points	10 points
	XC3-32PR-E	XC3-32PT-E	XC3-32PRT-E	XC3-32PR-C	XC3-32PT-C	XC3-32PRT-C	18 points	14 points
	XC3-48PR-E	XC3-48PT-E	XC3-48PRT-E	XC3-48PR-C	XC3-48PT-C	XC3-48PRT-C	28 points	20 points
	XC3-60PR-E	XC3-60PT-E	XC3-60PRT-E	XC3-60PR-C	XC3-60PT-C	XC3-60PRT-C	36 points	24 points

XC5 series models:

Model							Input (DC24V)	Output (R, T)
AC Power			DC Power					
Relay Output	Transistor Output	Mix output (R&T)	Relay Output	Transistor Output	Mix output (R&T)			
N P N Type	-	XC5-32T-E	XC5-32RT-E	-	XC5-32T-C	XC5-32RT-C	18 points	14 points
	XC5-48R-E	XC5-48T-E	XC5-48RT-E	XC5-48R-C	XC5-48T-C	XC5-48RT-C	28 points	20 points
	XC5-60R-E	XC5-60T-E	XC5-60RT-E	XC5-60R-C	XC5-60T-C	XC5-60RT-C	36 points	24 points
P N P Type	-	XC5-32PT-E	XC5-32PRT-E	-	XC5-32PT-C	XC5-32PRT-C	18 points	14 points
	XC5-48PR-E	XC5-48PT-E	XC5-48PRT-E	XC5-48PR-C	XC5-48PT-C	XC5-48PRT-C	28 points	20 points
	XC5-60PR-E	XC5-60PT-E	XC5-60PRT-E	XC5-60PR-C	XC5-60PT-C	XC5-60PRT-C	36 points	24 points

**Switch Quantity
Expansions**

XC — E $\frac{\bigcirc}{1}$ $\frac{\square}{2}$ $\frac{\bigcirc}{3}$ $\frac{\square}{4}$ $\frac{\bigcirc}{5}$ $\frac{\square}{6}$

- 1、 Series name
- 2、 E: Expansion
- 3、 Input points
- 4、 X: Input
- 5、 Output points
- 6、 Output format YR: Relay output YT: Transistor output

Model			I/O points	Input (DC24V)	Output (R, T)
Input	Relay Output	Transistor Output			
-	XC-E8YR	XC-E8YT	8 points	-	8 points
XC-E16X	-	-	16 points	16 points	-
-	XC-E16YR	XC-E16YT	16 points	-	16 points
-	XC-E8X8YR	XC-E8X8YT	16 points	8 points	8 points
	XC-E16X16YR	XC-E16X16YT	32 points	16 points	16 points
XC-E32X	-	-	32 points	32 points	-
-	XC-E32YR	-	32 points	-	32 points

1-3. Expansion's constitution and ID assignment

Expansion

XC series PLC can be used independently or used along with the expansions. The following is the chart of a basic unit with 7 expansions.

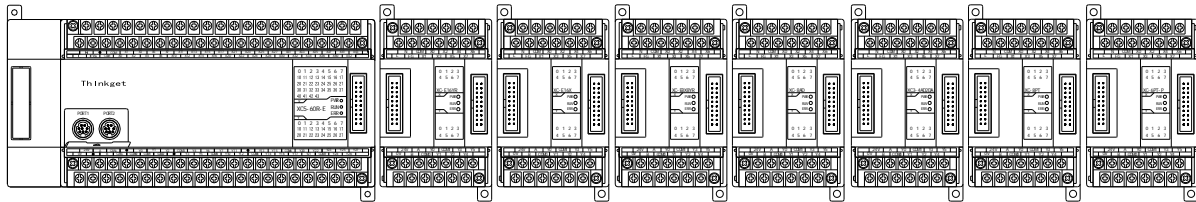

Constitution Rules

- Input/Output switch quantity is Octal
- Input/Output analog quantity is Decimal
- PLC main units can connect with 7 expansions and a BD module. The input/output type is not limited, both switch or analog quantity are available.

**ID
Assignment**

Unit	Type	ID (As register)	Max points/ Channels
Expansion 1#	Input switch quantity X	X100~X137	32 points
	Output switch quantity Y	Y100~Y137	32 points
	Input analog quantity ID	ID100~ID131	16 channels
	Output analog quantity QD	QD100~QD131	16 channels
	Module's set value D	D8250~D8259	-
Expansion 2#	Input switch quantity X	X200~X237	32 points
	Output switch quantity Y	Y200~Y237	32 points
	Input analog quantity ID	ID200~ID231	16 channels
	Output analog quantity QD	QD200~QD231	16 channels
	Module's set value D	D8260~D8269	-
Expansion 3#	Input switch quantity X	X300~X337	32 points
	Output switch quantity Y	Y300~Y337	32 points
	Input analog quantity ID	ID300~ID331	16 channels
	Output analog quantity QD	QD300~QD331	16 channels
	Module's set value D	D8270~D8279	-
Expansion 4#	Input switch quantity X	X400~X437	32 points
	Output switch quantity Y	Y400~Y437	32 points
	Input analog quantity ID	ID400~ID431	16 channels
	Output analog quantity QD	QD400~QD431	16 channels
	Module's set value D	D8280~D8289	-
Expansion 5#	Input switch quantity X	X500~X537	32 points
	Output switch quantity Y	Y500~Y537	32 points
	Input analog quantity ID	ID500~ID531	16 channels
	Output analog quantity QD	QD500~QD531	16 channels
	Module's set value D	D8290~D8299	-
Expansion 6#	Input switch quantity X	X600~X637	32 points
	Output switch quantity Y	Y600~Y637	32 points
	Input analog quantity ID	ID600~ID631	16 channels
	Output analog quantity QD	QD600~QD631	16 channels
	Module's set value D	D8300~D8309	-
Expansion 7#	Input switch quantity X	X700~X737	32 points
	Output switch quantity Y	Y700~Y737	32 points
	Input analog quantity ID	ID700~ID731	16 channels
	Output analog quantity QD	QD700~QD731	16 channels
	Module's set value D	D8310~D8319	-
BD Board	Input switch quantity X	X1000~X1037	32 points
	Output switch quantity Y	Y1000~Y1037	32 points
	Input analog quantity ID	ID1000~ID1031	16 channels
	Output analog quantity QD	QD1000~QD1031	16 channels
	Module's set value D	D8320~D8329	-

1-4. General Specification

General Specification

Items	Specifications
Insulate voltage	Up to DC 500V 2M Ω
Anti-noise	1000V 1uS pulse per minute
Ambient temperature	0°C~60°C
Ambient humidity	5%~95%
COM 1	RS-232, connect with host machine、HMI program or debug
COM 2	RS-232/RS-485, connect with network or aptitude instrument、inverters etc.
COM 3	BD board COM port RS-232C/RS-485
COM 4	CANBUS COM port (XC5 series)
Installation	Can use M3 screw to fix or install directly on DIN46277 (Width 35mm) orbit
Grounding	The third type grounding (can't public ground with strong power system.)

Performance

XC3 series:

Item	Specification		
	14 points	24/32 points	48/60 points
Program executing format	Loop scan format、time scan format		
Program format	Both statement and ladder		
Dispose speed	0.5us		
Power cut retentive	Use FlashROM and Li battery		
User program's capacity	2500 steps	8000 steps	
I/O points	8 I / 6 O	Input 14/18 points Output 10/14 points	Input 28/36 points Output 20/24 points
Interior coil's points (M)	8512 points		
Timer (T)	Points	620 points	
	Spec.	100mS timer: Set time 0.1~3276.7 seconds 10mS timer: Set time 0.01~327.67 seconds 1mS timer: Set time 0.001~32.767 seconds	
Counter (C)	Points	635 points	
	Spec.	16 bits counter: set value K0~32767 32 bits counter: set value K0~2147483647	
Data Register (D)	8512 words		
FlashROM Register (FD)	2048 words		
High speed dispose function	High speed count、pulse output、external interrupt		
Setting of time scan space	0~99mS		
Password protection	6 bits ASCII		
Self diagnose function	Power on self-diagnose、Monitor timer、grammar check		

Note: If choose "PLC Operation--Secret Download", "User program's capacity"

1-5. Shape and Size

Exterior Size

XC1 series 16 points main units

XC3 series 14 points main units (Including 16 points expansions)

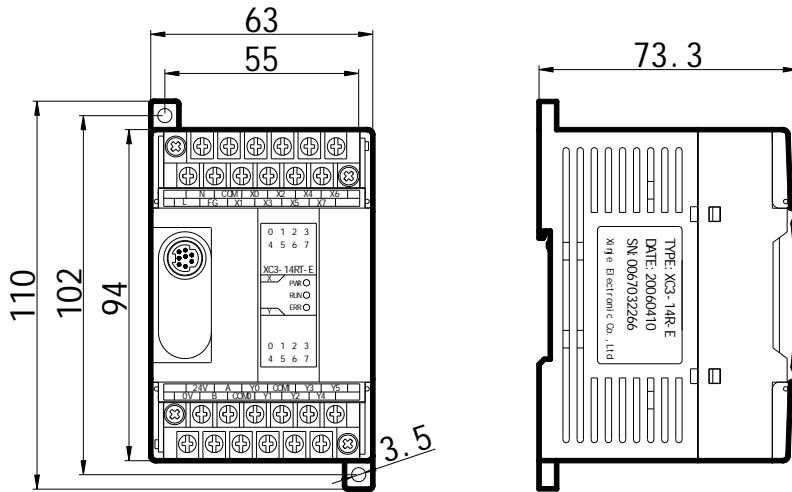

XC1 series 32 points main units (Including 24 points main units)

XC3 series 32 points main units (Including 24 points main units、 32 points expansions)

XC5 series 32 points main units

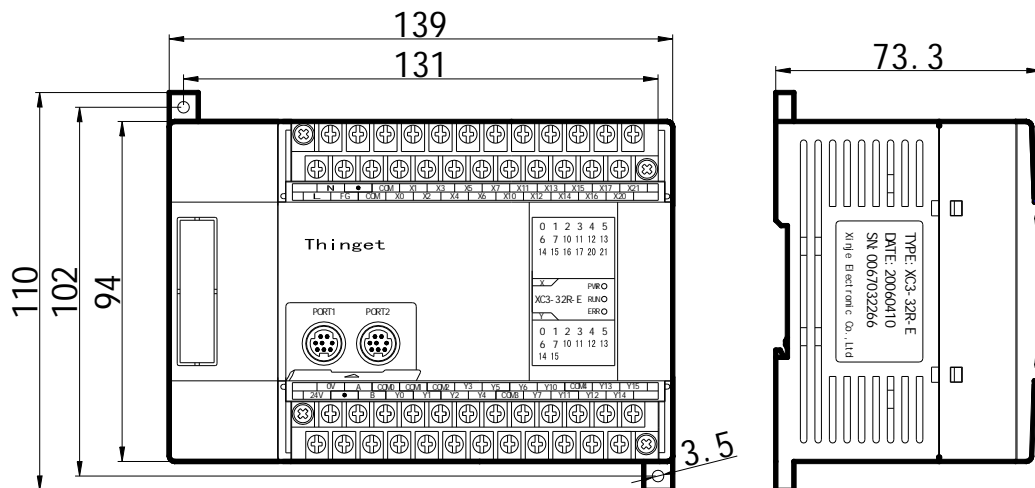

XC3 series 60 points main units (Including 48 points main units)

XC5 series 60 points main units (Including 48 points main units)

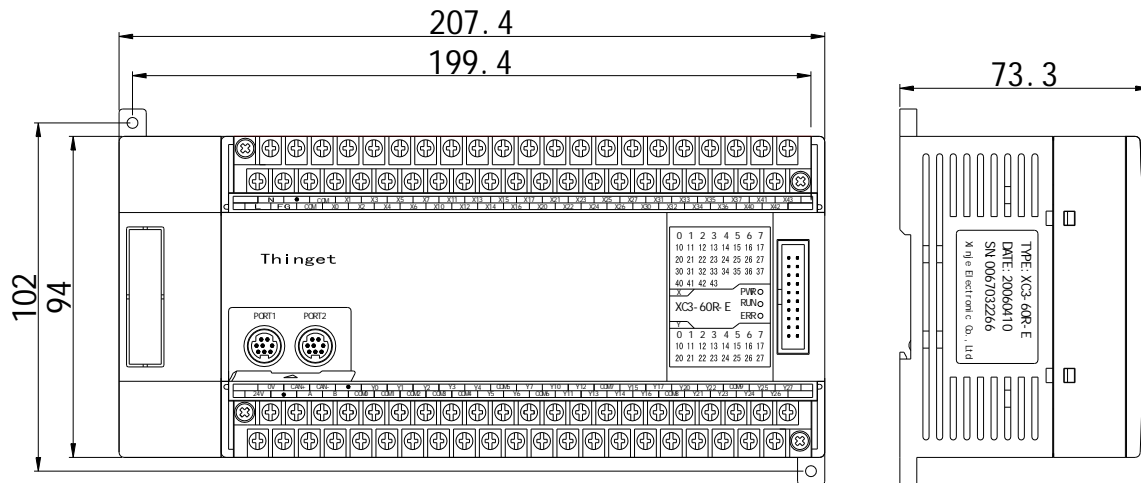

1-6. Terminal arrangement

Main Units

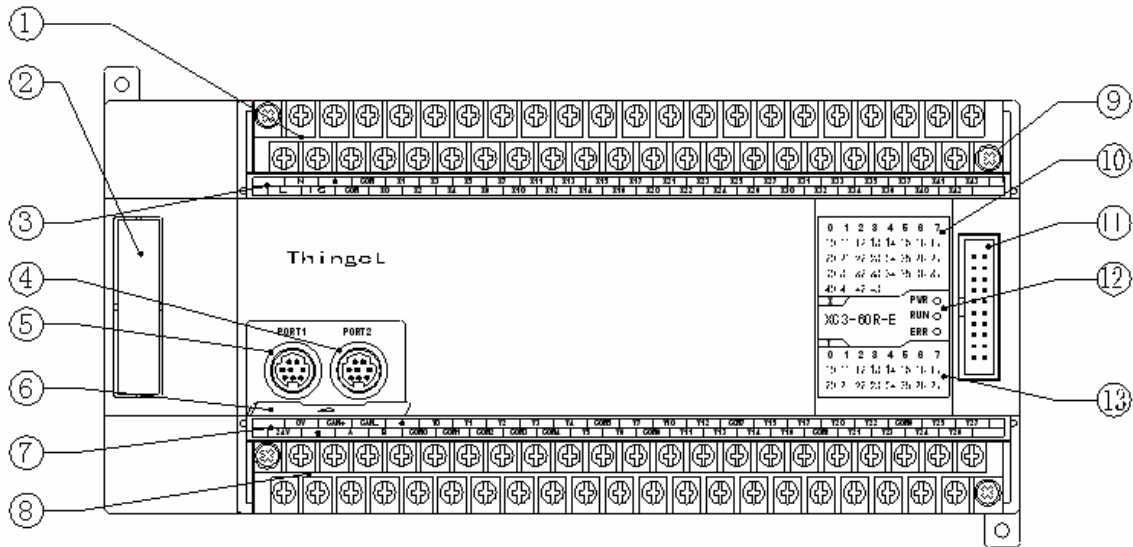

- ① Input terminals ② BD expansion ③ Input label ④ COM port
- ⑤ COM port ⑥ COM port's cover board ⑦ Output label
- ⑧ Output terminals ⑨ Screws ⑩ Input indicate LED ⑪ Extension port
- ⑫ Programming status indicate LED ⑬ Output indicate LED

XC3- 60 main units、XC5- 60 main units: 36 Input/24 Output

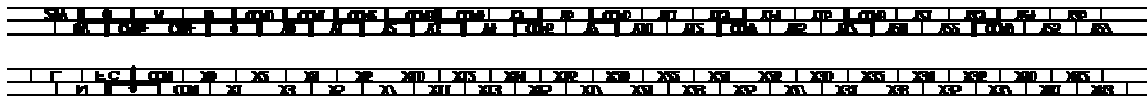

XC3- 48 main units、XC5- 48 main units: 28 Input /20 Output

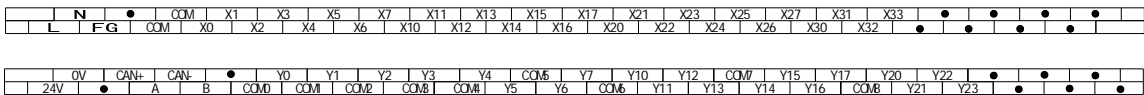

XC1- 32 main units、XC3- 32 main units、XC5- 32 main units: 18 Input /14 Output

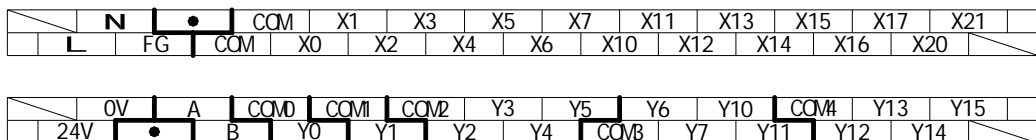

XC1- 24 main units、XC3- 24 main units: 14 Input /10 Output

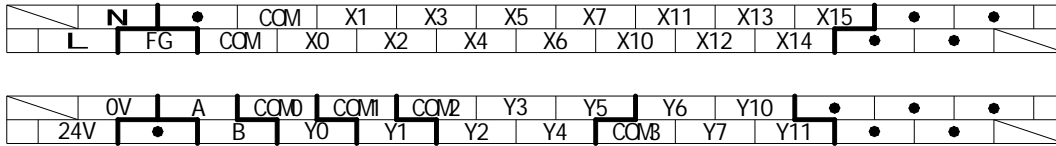

XC3- 14 main units: 8 Input /6 Output

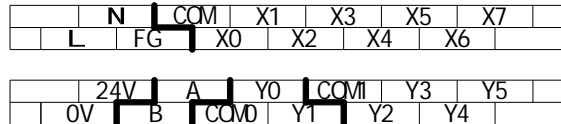

XC1- 16 main units: 8 Input /8 Output

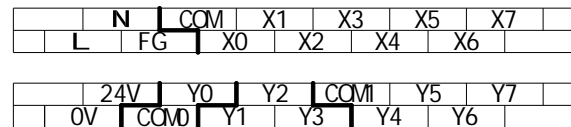

Expansions

XC-E8X8YR

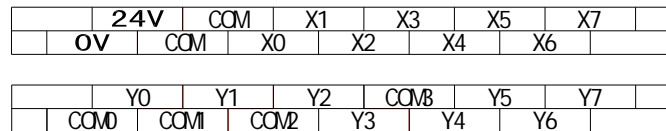

XC-E16X

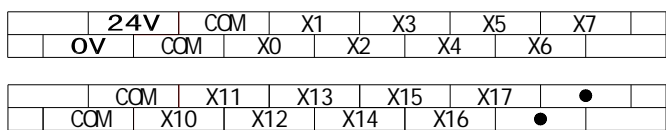

XC-E16YR

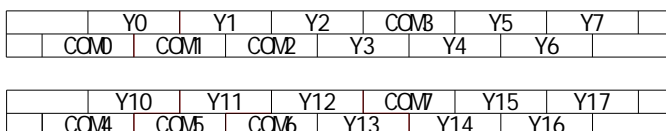

1-7. COM Port Definition

COM 1

Pin of COM 1:

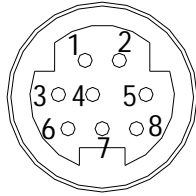

- 2: PRG
- 4: RxD
- 5: TxD
- 6: VCC
- 8: GND

Mini Din 88 core socket (hole)

COM 2

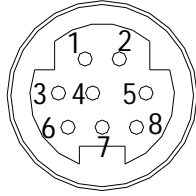

D

Mini Din 88 core socket (hole)

Program Cable

Connection of programmable cable is the following:

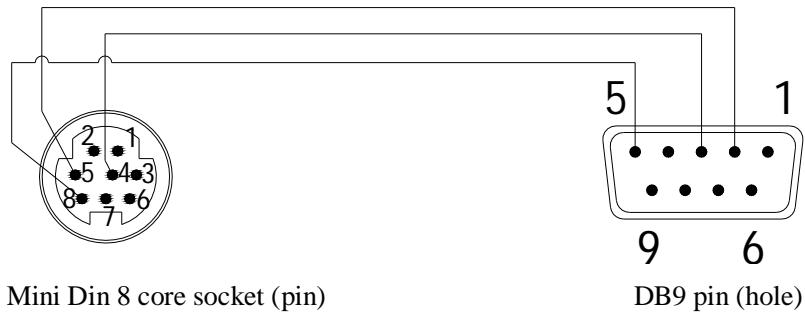

Mini Din 8 core socket (pin)

DB9 pin (hole)

MEMO

2. Power circuit's specification、input/output specification and exterior layout

In this chapter, we'll tell the power constitution, interior signal circuit's composing, output circuit's composing and exterior layout of XC series PLC.

When using the extend modules or special modules at the same time, please connect the power according to the user manual.

2-1. Power Specification

2-2. AC Power、DC Input Type

2-3. Input Specification

2-4. DC input signal disposal (AC power type)

2-5. Output Specification

2-6. Disposal of relay output circuit

2-7. Disposal of transistor output circuit

2-1. Power Specification

For the power specification of XC series programmable controller's basic units, please see the following table:

AC Power Type		
Rated voltage	AC100V~240V	
Voltage allow bound	AC90V~265V	
Rated frequency	50/60Hz	
Allow momentary power-cut time	Interrupt time ≤ 0.5 AC cycle, alternation ≥ 1 sec	
Impact current	Max 40A 5mS below/AC100V max 60A 5mS below /AC200V	
Max power consumption	12W	
Power for sensor use	24VDC? 10% max 400mA	



- To avoid voltage decrease, please use the power cable thicker than 2mm^2
- Even appear power cut within 10ms, PLC can still go on working. But if long time power cut or abnormal power decrease, PLC will stop working, output will also appear OFF status, when recover power supply, the PLC will auto start to work.
- Connect the grounding terminals of basic units and extend modules together, then ground

DC power type		
Rated voltage	DC24V	
Voltage allow bound	DC21.6V~26.4V	
Input current (Only basic unit)	120mA DC24V	
Allow momentary power-cut time	10mS DC24V	
Impact current	10A DC26.4V	
Max power consumption	12W	
Power for sensor use	24VDC? 10% Max 400mA	

2-2. AC Power、DC Input Type

Constitution and Connection

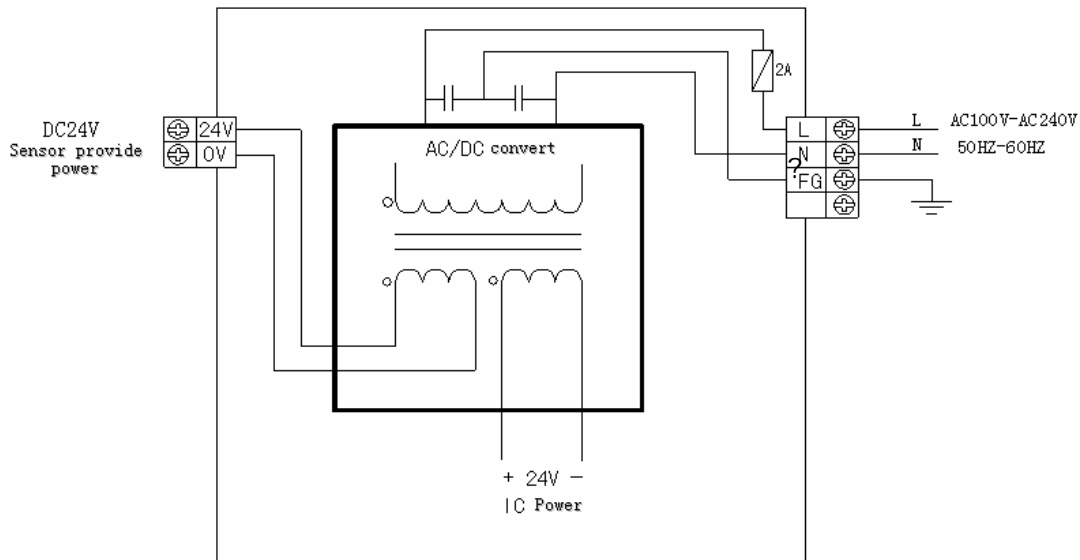

- The power is connected between L and N terminals.
- 24+、COM terminals can be used as power 400mA/DC24V which supply sensor. Besides, this terminal can't be given power from outside.
- terminal is vacant terminal, please don't go on exterior connection or use it as relay terminal.
- Please connect the basic unit with extend module's terminal.

2-3. Input Specification

Basic Units

Input signal's voltage	DC24V? 10%
Input signal's current	7mA/DC24V
Input ON current	Up to 4.5mA
Input OFF current	Low than 1.5mA
Input response time	About 10ms
Input signal's format	Contact input or NPN open collector transistor
Circuit insulation	Photo-electricity coupling insulation
Input action's display	LED light when input ON

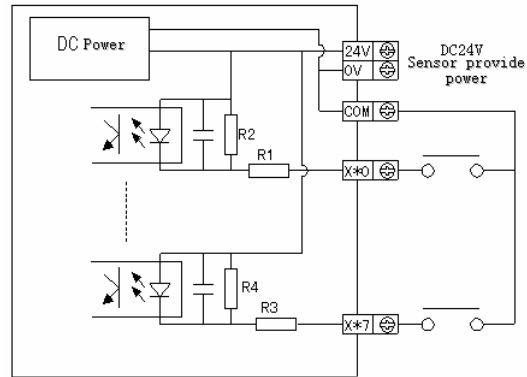

Expansions

Input signal's voltage	DC24V? 10%
Input signal's current	7mA/DC24V
Input ON current	Up to 4.5mA
Input OFF current	Below 1.5mA
Input response time	About 10ms
Input signal's format	Contacts input or NPN open collector transistor
Circuit insulation	Photo-electricity coupling insulation
Input action's display	LED light when input ON.

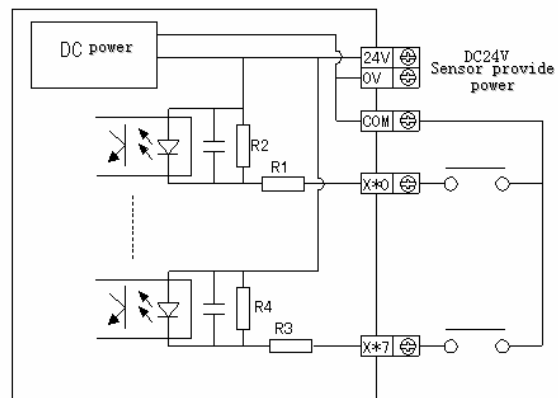

2-4. DC Input Signal's Disposal (AC Power Type)

DC input signal

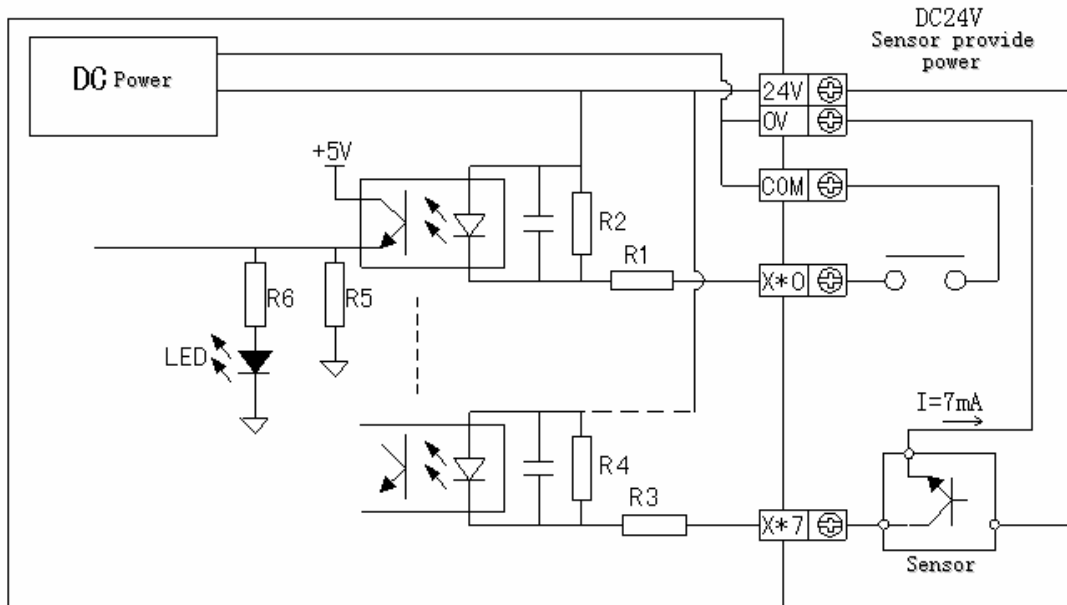

- **Input terminal**
When connect input terminal and **COM** terminal with contacts without voltage or NPN open collector transistor, if input is ON, LED lamp lights, which indicates input. There are many **COM** terminals to connect in PLC.
- **Input circuit**
Use optical coupling instrument to insulate the input once circuit and twice circuit, There's a C-R filter in the twice circuit. It is set to avoid wrong operation caused by vibration of input contacts or noise along with input signal. As the preceding reason, for the changing of input ON→OFF, OFF→ON, in PLC, the response time delays about 10ms. There's a digital filter inside X000~X015. This kind of filter can vary from 0~15ms according to the special register (D8020).
- **Input sensitive**
The PLC's input current is DC24V 7mA, but to be safe, it needs current up to 3.5mA when it's ON, lower than 1.5mA when it's OFF.

Exterior
circuit used

XC series PLC's input power is supplied by its interior 24V power, so if use exterior power to drive photoelectricity sensor etc., this exterior power should be DC24V? 4V, please use NPN open collector type for sensor's output transistor

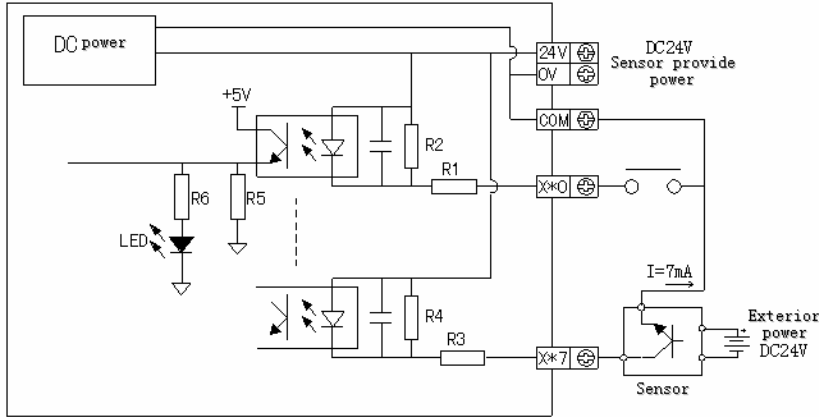

Input Connection

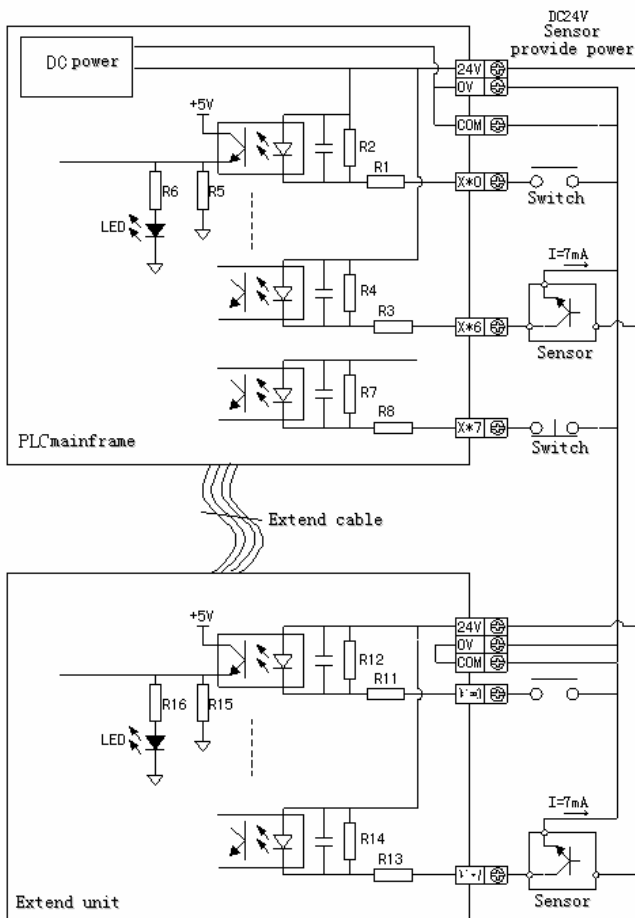

2-5. Output Specification

Relay output

Interior power		Below AC250V、DC30V
Circuit insulation		Mechanism insulation
Action denote		LED indicate lamp
Max load	Resistant load	3A
	Induce load	80VA
	Lamp load	100W
Open circuit's leak current		-
Mini load		DC5V 2mA
Response time	OFF→ON	10ms
	ON→OFF	10ms

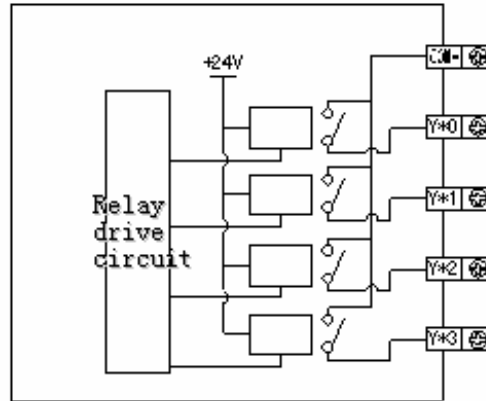

Transistor Output

Interior power		Below DC5~30V
Circuit insulation		Optical coupling insulation
Action denote		Indicate lamp LED
Max load	Restance load	0.8A
	Induce load	12W/DC24V
	Lamp load	1.5W/DC24V
Open circuit's leak current		-
Mini load		DC5V 2mA
Response time	OFF→ON	Below 0.2ms
	ON→OFF	Below 0.2ms

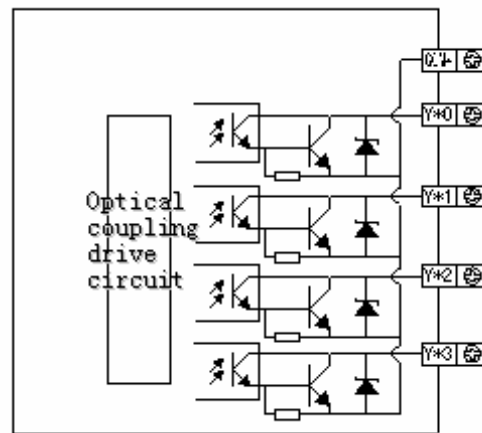

2-6. Disposal of Relay Output Circuit

Relay output circuit

- **Output terminals**
Relay output type includes 2~4 public terminals. So each public-end unit can drive different power-voltage system's (E.g.: AC200V, AC100V, DC24V etc.) load.
- **Circuit's insulation**
Between the relay output coils and contacts, PLC's interior circuits and exterior circuits, load circuits are electric insulation. Besides, each public-end blocks are separate.
- **Action display**
LED lamp lights when output relay's coils galvanize, output contacts are ON.
- **Response time**
From the output relay galvanize (or cut) to the output contacts be ON (or OFF), the response time is about 10ms
- **Output current**
The current-voltage below AC250V can drive the load of pure resistace 2A/1 point、 inductance load below 80VA (AC100V or AC200V) and lamp load below 100W (AC100V or AC200V) .
- **Open circuit's leak current**
When the output contact be OFF and there's no leak current, can directly drive Ne lamp etc.
- **The life of relay output contacts**
Standard life of induce AC load such as contactor、 electromagnetism valve: 5 million times for 20VA load. Cut power device's life according to the company's test: for 80VA load, the action life is up to 2 million times. But if the load parallel connect with surge absorber, the life will be greatly improved!

Output connection example

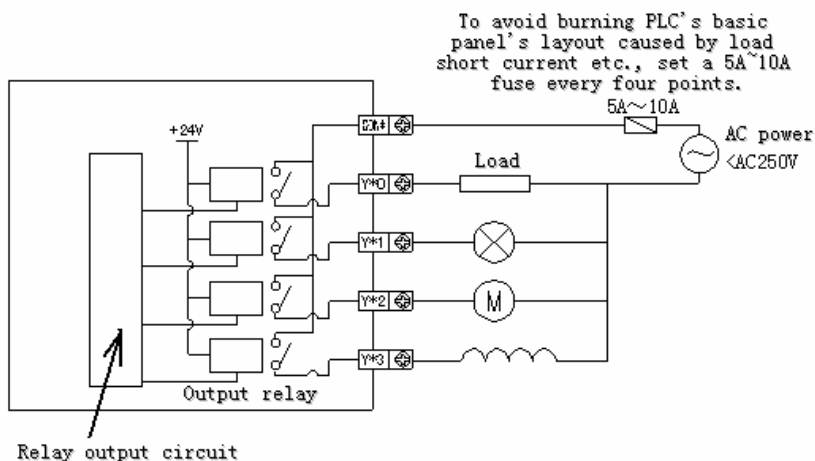

**Constitution
of output
circuit**

- For DC induce load, please parallel connect with commutate diode. If not connect with the commutate diode, the contact's life will be decreased greatly. Please choose the commutate diode which allow inverse voltage endurance up to 5~10 times of the load's voltage, ordinal current exceeds load current.
- Parallel connect AC induce load with surge absorber can reduce noise.

DC load

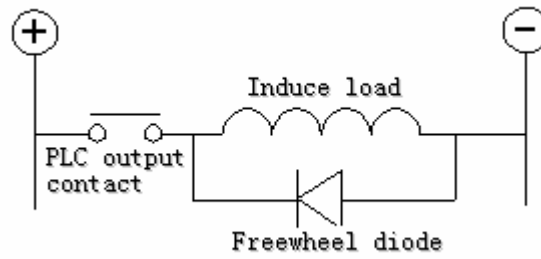

AC load

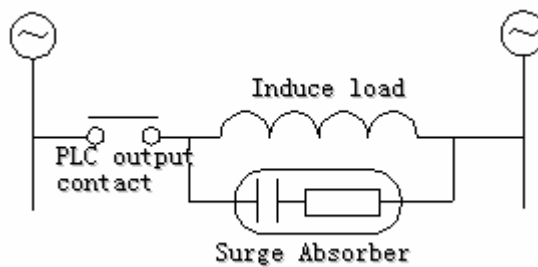

2-7. Disposal of Transistor Output Circuit

Transistor output circuit

- Output terminal
Basic unit's transistor output has 1~4 public-end output.
- Exterior power
Please use DC5~30V steady-voltage power for load drive,
- Circuit insulation
Use photoelectricity coupling device to insulate PLC's interior circuit and output transistor. Besides, each public block is separate.
- Action denote
When drive optical coupling, LED lights, output transistor is ON.
- Response time
From photoelectricity coupling device drive (or cut) to transistor ON (or OFF), the time PLC uses is below 0.2ms.
- Output current
The current is 0.5A per point. But as restrict by temperature goes up, the current is 0.8A every four points.
- Open circuit's current
Below 0.1mA

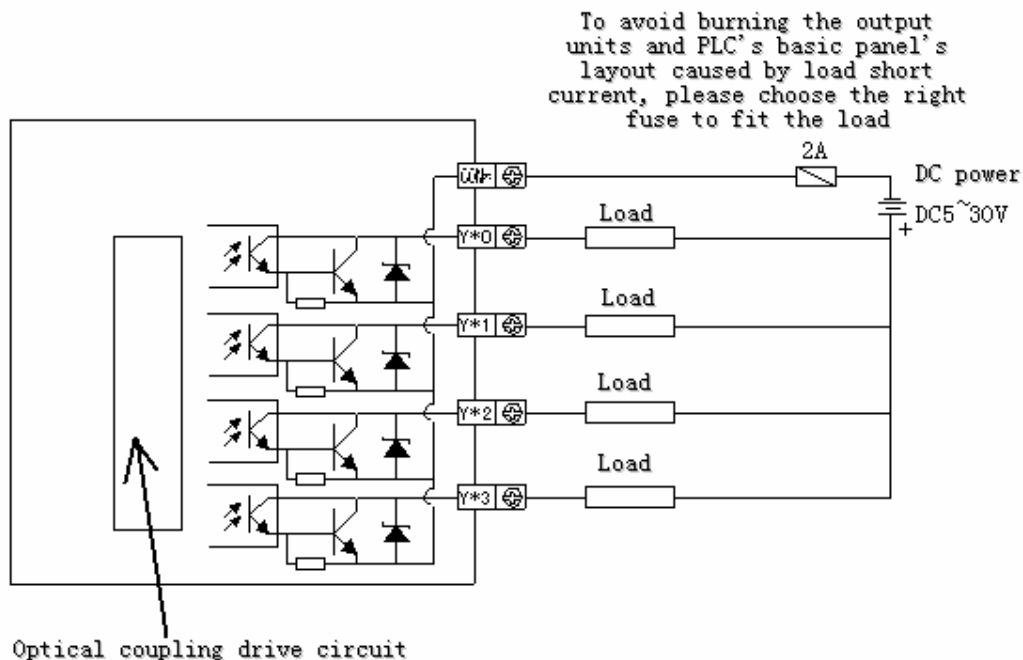

E.g. : The following is the connection graph of -RT type PLC with step motor driver.

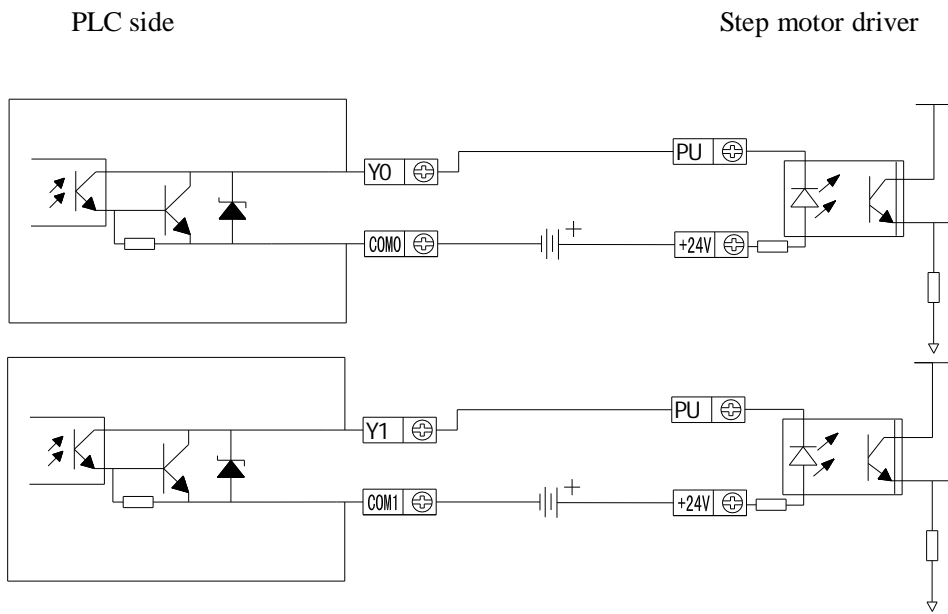

MEMO

3. Each Soft Unit's Usage and Function

This chapter, we'll give some description of the PLC's data and the function of interior input/output relay, auxiliary relay, status, counter, data register etc. This item is the base to use PLC.

3-1. Every Soft Unit of PLC

3-2. Soft Unit's ID List

3-3. Disposal of Data

3-4. Some Encode Principle of Soft Units

3-5. Timer's ID and Function [T]

3-6. Counter's ID and Function [C]

3-7. Note Items

3-1. Every Soft Unit of Programmable Controller

In the programmable controller, there are many relays、timers and counters, they all have countless “a” contacts (Normally open contacts) and “b” contacts (Normally closed contacts), Connect these contacts and coils to constitute sequential control circuit. The following, we’ll briefly introduce each soft unit:

【Input (X) and output (Y) relay】

- In each basic unit, assign the ID of input relay, output relay in the format of X000~X007, X010~X017...,Y000~Y007, Y010~Y017... this octal format. The ID of extension is connected behind basic unit.
- The ID of expansion obeys the principle of channel 1 starts from X100/Y100, channel 2 starts from X200/Y200... 7 expansions could be connected totally.
- Use digital filter in the special input filter of input relay, so you can use the program to change the sieve value. So in the high-speed receive application, you can assign this type of relay’s ID No.

【Auxiliary relay (M)】

- Auxiliary relay is the relay inside the programmable controller, this type of output relay is different from input/output relay, it can’t gain exterior input, it also can’t drive exterior load, it can only be used in the program.
- The relay used for retentive can still save its ON/OFF status in the case of PLC power cut.

【Status (S)】

- Relay used as step ladder chart.
- When not used as working procedure No., it’s the same with auxiliary relay and can be used as common contact/coil to carry on programming. Besides, it can also be signal alarm to diagnose exterior trouble.

【Timer (T)】

- Timer could carry on plus operation to 1ms, 10ms, 100ms etc. time pulse in PLC, When reach certain set value, output contact act.
- T100~T199 are timers with the unit of 100ms clock pulse, their current values are the accumulate values. So, even though timer coil’s drive input is cut, they will still hold the current value, go on accumulating the action.

【Counter (C)】

- The counters can be divided into the following sorts according to their usage and purpose:

[Used for interior count] Common use / power failure retentive use

16 bits counter: Used for plus count, count bound: 1~32,767

32 bits counter: Used for add / minus count, count bound: -2,147,483,648~+2,147,483,647

These counters are used for PLC's interior signals, usually their response speed is below 10Hz.

[Used for high-speed count] For power failure retentive use

32 bits counter: For plus / minus count, count bound: -2,147,483,648~+2,147,483,647

(Single phase plus count, single phase plus/minus count, AB phase count) allocate to the special input points.

High-speed counter can count with the frequency below 200kHz, independent with the PLC's scan cycle.

【Data register (D)】

- Data register is the soft unit used by data register to save data. XC series PLC's data registers are all 16 bits (The high bit is the sign bit), Combine two registers can carry on 32 bits data disposal (The high bit is the sign bit).

Just the same with other soft units, data registers can also be divided to be two types: for common use and power failure retentive use.

【Constant (K)、(H)】

- In the diverse value used by PLC, K means decimal integer, H means Hex. Value. They are used to be the set value and current value for the timer and counter, or applied instructions' operands.

【Pointer (P) (I)】

- Pointers are used for branch and interrupt. The pointer (P) used by branch is the jump aim used for condition jump or subroutine jump. Pointer used for interrupt is used for the assigned input interrupt, time interrupt.

3-2. Device's ID List

For the allocate of device's ID, please see the following list:

Besides, when connect input / output expansions and special expansions on the basic units, for the input / output relay's No., please refer to the user manual.

Mnemonic	Name	Bound			points		
		14 points	24\32 points	48 \60 points	14 points	24\32 points	48 \60 points
X	Input relay	X000~X007	X000~X015 X000~X021	X000~X033 X000~X043	8 points	14\18 points	28\36 points
Y	Output relay	Y000~Y005	Y000~Y011 Y000~Y015	Y000~Y023 Y000~Y027	6 points	10\14 points	20\24 points
M	Interior relay	M0~M2999 【M3000~M7999】			8000		
		M8000~M8511 for special using			512		
S	Flow	S0~S511 【S512~S1023】			1024		
T	Timer	T0~T99: 100ms not accumulation			620		
		T100~T199: 100ms accumulation					
		T200~T299: 10ms not accumulation					
		T300~T399: 10ms accumulation					
		T400~T499: 1ms not accumulation					
		T500~T599: 1ms accumulation					
		T600~T618: 1ms with interruption precise time					
C	Counter	C0~C299: 16 bits forth counter			635		
		C300~C598: 32 bits forth/back counter					
		C600~C634: high-speed counter					
D	Data Register	D0~D3999 【D4000~D7999】			8000		
		For special usage D8000~D8511			512		
FD	FlashROM Register	FD0~FD1535			1536		
		For special usage FD8000~FD8511			512		

◆ **NOTE:**

- ※1. The memorizer area in 【 】 is the defaulted power failure retentive area; soft elements D、M、S、T、C can be set to change the power failure retentive area. For the details, please see the following table
- ※2. FlashROM register needn't set power failure retentive, its data won't lose when power is cut (No battery).
- ※3. The serial No. of input coil、output relay are octal data, other memorizers' No. are all algorism data.

Setting of soft unit's power failure saving area:

Mnemonic	Set area	Function	System's defaulted value	Memory bound of power drop
D	FD8202	Start denotation of D power cut save area	4000	D4000~D8000
M	FD8203	Start denotation of M power cut save area	3000	M3000~M8000
T	FD8204	Start denotation of M power cut save area	620	Not set
C	FD8205	Start denotation of C power cut save area	320	C320~C640
S	FD8206	Start denotation of S power cut save area	512	S512~S1024

3-3. Data Disposal of Programmable Controller

According to different usage and purpose, XC series programmable controllers use 5 types of count format. For their usage and function, see the following:

《DEC》(DEC: DECIMAL NUMBER)

- The set value of timer and counter (K constant)
- The ID of auxiliary relay (M), timer (T), counter (C), status (S) (Soft unit's number)
- Assign the value in the operands and instruction's action (K constant)

《HEX》(HEX: HEXADECIMAL NUMBER)

- The same with DEC data, it is used to assign the value in the operands and instruction's action (H constant)

《BIN》(BIN: BINARY NUMBER)

- Just as said before, carry on data allocation to timer, counter or data register in the format of DEC. or Hex., But in the PLC, these data are all be put in the format of binary data. And, when carry on monitor on the peripheral device, these soft units will auto switch to be DEC. data as shown in the graph. (they can also switch to be Hex. Data.) .

《OCT》(OCT: OCTAL NUMBER)

- The input relay, output relay's soft units' ID of XC series PLC are allocate in the format of OCT data. So, it can go on carry of [1-7, 10-17, ... 70-77, 100-107].

《BCD code》(BCD: BINARY CODE DECIMAL)

- BCD is the method which use 4 bits binary to denote decimal 0~9. It's easy to despose bit. So, BCD is available to denote digital switch or 7 segments display control.

《Other data (float)》

- XC series PLC has the function of high precision floating point operation. Use binary floating point data to execute floating point operation, use decimal floating value to execute monitor.

3-4. Some encode principles of device

1、Data register could be used as offset (indirect assignment)

Format: $D_n[D_m]$ 、 $X_n[D_m]$ 、 $Y_n[D_m]$ 、 $M_n[D_m]$ etc.

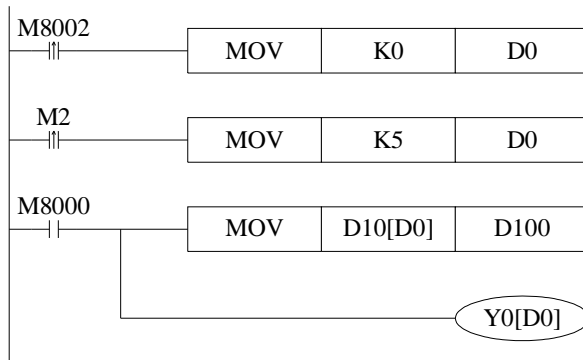

In the preceding example, when $D0=0$, then $D100=D10$, $Y0$ is ON;

When $M2$ turns from OFF to be ON, $D0=5$, then $D100=D15$, $Y5$ is ON.

When $D10[D0]=D[10+D0]$, $Y0[D0]=Y[0+D0]$.

- Word's offset composed by bit soft units: $DX_n[D_m]$ means $DX[n+D_m]$;
- Soft units with offset, the offset could only be denoted with soft device D.

2、Bit units compose word

Input X、output Y、middle coil M could compose 16 bits word. E.g. $DX0$ means $X0\sim X17$ compose to be a 16 bits data. $DX20$ means $X20\sim X37$ combines a 16 bits data.

Format: Add a D before bit device

Bit devices combine to be word devices: DX 、 DY 、 DM 、 DS 、 DT 、 DC

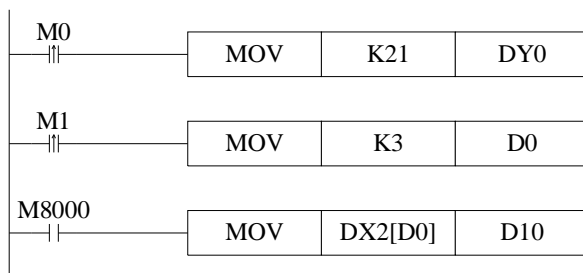

In the preceding example, when $M0$ turns from OFF to be ON, the value of the word $DY0$ composed by $Y0\sim Y17$ equals 21, i.e. $Y0$ 、 $Y2$ 、 $Y4$ turns to be ON status.

Before $M1$ be activate, when $D0=0$, $DX2[D0]$ means a word composed by $X2\sim X21$;

When $M1$ turns from OFF to be ON, $D0=3$, then $DX2[D0]$ means a word composed by $X5\sim X24$

- DX_n (the bound of "n" is the exact bound of "X"), choose 16 points from the head to the end, add 0 if not enough.
- Please note, the word composed by bit device couldn't carry on bit searching address.

3、Bit of word device

Format: Dn.m

Register could carry on bit searching address, e.g. Dn.m means number “m” bit of Dn data register ($0 \leq m \leq 15$).

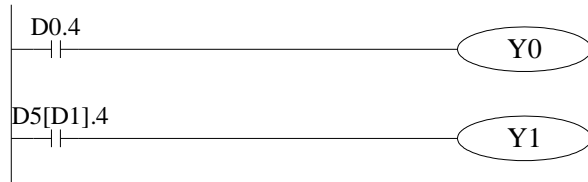

In the preceding example, D0.4 means when the No.4 bit of D0 is 1, Y0 set ON;

D5[D1].4 means bit searching address with offset, if D1=5, it says D5[D1] means the number 4 bit of D10.

- The bit of word device with offset is denoted as Dn[Dm].x
- Please note, to the bit of word device, they couldn't combined to be word device.

4、T/C means the difference of register's word and bit

To T and C register, Tn/Cn means be a bit register or a word register should be distinguished by the instructions.

T、C could denote the status of timer、counter, or the current value of time、counter, it is distinguished by the instructions.

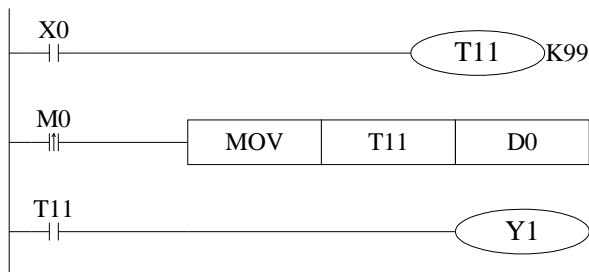

In the preceding example, MOV T11 D0, T11 means word register;

LD T11, T11 means bit register.

5、Tag type: P, I

e.g.: P means the tag which using CJ instruction or CALL instruction which could jump; I means interrupt tag.

3-5. Timer's Number and Function [T]

Timer's number

Please see the following table for the timer's [T] number (the number is assigned according to Hex.)

100ms not accumulated (16 bits)	T0~T99
100ms accumulated (16 bits)	T100~T199
10ms not accumulated (16 bits)	T200~T299
10ms accumulated (16 bits)	T300~T399
1ms not accumulated (16 bits)	T400~T499
1ms accumulated (16 bits)	T500~T599

Function

The timer accumulates clock pulse of 1ms, 10ms, 10ms inside PLC. When reach the set value, the output contact activates.

The common timers don't set exclusive instructions, use OUT instruction to time; use constant K in the program memory, also you could use register's content (D) to indirect assign.

Common format

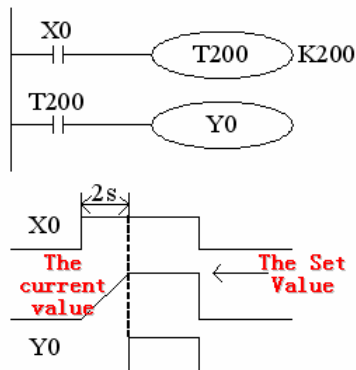

If drive input X000 of time coil T200 is ON, T200 accumulates 10ms clock pulse with the current value timer. If this current value equals the set value K200, timer's output contact activates. That is, output contact activates after 2 seconds of coil driving. Driving input X000 cut or power cut, timer reset, output contact reset.

Accumulation format

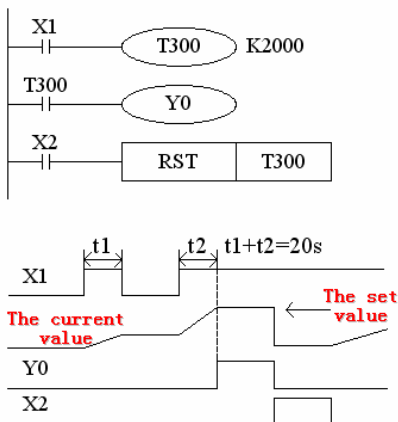

If the drive input X001 of timer's coil T300 is ON, T300 accumulates 10ms clock pulse with the current value counter. When the value reaches the set value K2000, counter's output contact activates. In the count process, even the input X001 cut or drop power, when start again, go on counting, its accumulation time is 20 seconds. When reset input X002 is ON, timer reset, output contact reset.

Assign method of the set value

《Constant assignment (K)》

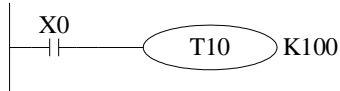

T10 is a timer with the unit of 100ms. Assign 100 as a constant, then 0.1s? 100=10s timer work.

《Indirect assignment (D)》

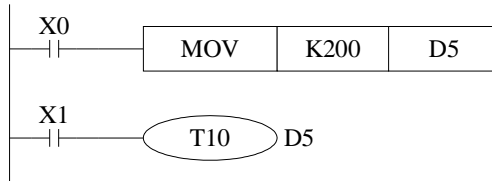

Write content in indirect data register to program or input via data switch. When assigned as power cut retentive register, please note that voltage low will cause the set value instable.

The Time Value

The count format of Timers T0~T599 is 16 bits linear increment mode (0~K32,767). If the timer's count value reaches the maximum value K32767, the timer will stop timing, the timer's status will remain the same status.

Action

《Output delay on-off timer》

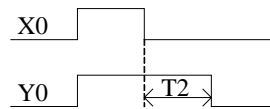
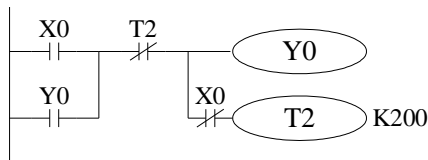

When X000 is ON, output Y000;
If X000 changes from ON to be OFF, T2 (20 seconds) will be delayed, then will output Y000 cut.

《Flicker》

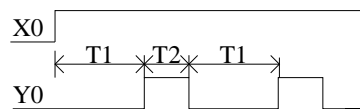
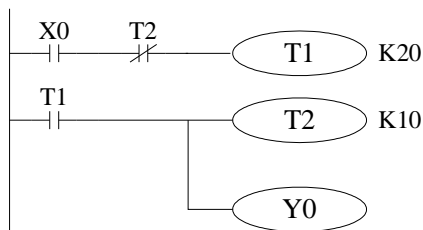

If X000 activates, Y000 starts flicker output.
T1 controls the OFF time of Y000, T2 controls the ON time of Y000.

3-6. Counter's ID and function [C]

Counter's ID

For the counter's number (C), please refer to the following table:

16 bits positive counter	C0~C299
32 bits positive/negative counter	C300~C598 (C300, C302...C598) (Each one engrosses 2 counter No.) The number must be even.
High speed counter	C600~C634(C600,C602...C634) (Each one engrosses 2 counter No.) The number must be even

Counter's characters

The characters of 16 bits counter and 32 bits counter are shown below:

Items	16 bits counter	32 bits counter
Count direction	Positive	Positive/negative
The set value	1~32,767	-2,147,483,648~+2,147,483,647
The assigned set value	Constant K or data register	Same as the left, but data register must be in a couple
Changing of the current value	Change after positive count	Change after positive count (Loop counter)
Output contact	Hold the action after positive count	Hold the action after positive count, reset if negative count
Reset activates	When executing RST command, counter's current value is 0, output contacts recover	
The current value register	16 bits	32 bits

Function

About the assignment of normally used counter and power failure retentive counter, they could be changed in the method of changing FD parameters' setting via the peripheral device.

16 bits counter For normally use or power count retentive

16 bits binary increment counter, its valid setting value is K1~K32,767 (Decimal constant). The set value K0 and K1 have the same meaning, i.e. act when output contacts at the beginning of first time count.

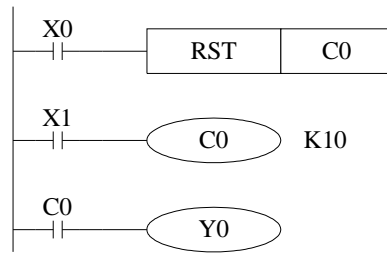

If cut the PLC's power, then the value of the normally use counter will be reset. However, counter used by power cut retentive could save the count value after power cut, and the counter will go on counting from the value.

- Every time when X001 drives coil C0, the counter's current value will increase. When execute the coil instruction the tenth time, output contact acts. Later, even X001 activates, counter's current value will not change.
- If reset input X000 is ON, execute RST instruction, counter's current value is 0, output contacts activates.
- For the counter's set value, it could not only set by constant K, but also be assigned by data register's ID. E.g. assign D10, if the content of D10 is 123, it's the same with setting K123.
- When write the set value to the current value register via MOV instruction etc. When input next time, output coil gets, current value register turns to the set value.

32 bits counter For normally use or power count retentive

For 32 bits binary increment counter, its valid bound is K1~K2,147,483,647 (Decimal constant). With special auxiliary relay M8238, assign the direction of bits positive/negative counter's (C300~C498) direction

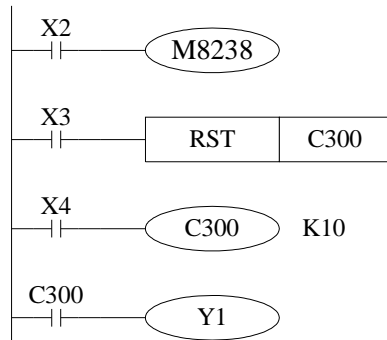

- If X2 drives M8238, then it is negative count; If no drive, then it is positive count.
- According to constant K or to the content of data register D, set the value to be positive. Treat contents in consecutive data register as a pair, and dispose it as 32 bits data. So, when assign D0, dispose D0 and D1 as a 32 bits set data. If use count input X004 to drive coil C300, execute increase count.

- When reset input X3 is ON, execute RST instruction, counter's current value turns to be 0, output contact resets.
- When use counter as power cut retentive, counter's current value, output contact's action and reset status cut power retentive.
- 32 bits counter can also be used as 32 bits data register. But 32 bits data register can't be used as device in 16 bits applied instructions.

Assign method of the set value

◆ 16 bits counter

《Constant assignment (K)》

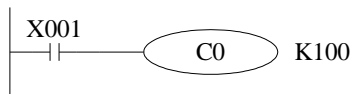

《Indicate assignment (K)》

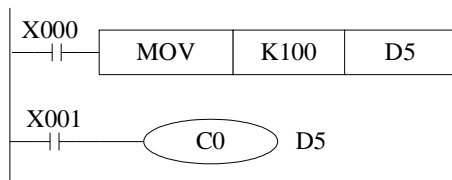

◆ 32 bits counter

《Constant assignment (K)》



《Indicate assignment (K)》

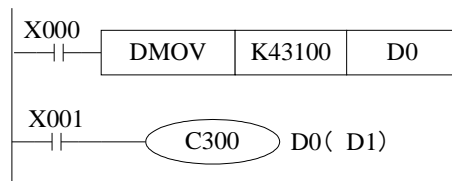

The count
value

The count mode of counters T0~T599 is 16 bits linear increment mode (0~K32767). When counter's count value reaches the max value K32767, the counter will stop counting, the counter's status will remain.

3-7. Some Points to Note

《Action order of input/output relay and response delay》

◆ Input disposal

Before PLC executing the program, read all the input terminal's ON/OFF status of PLC to the image area. In the process of executing the program, even the input changed, the content in the input image area will not change. However, in the input disposal of next scan cycle, read out the change.

◆ Output disposal

Once finish executing all the instructions, transfer the ON/OFF status of output Y image area to the output lock memory area. This will be the actual output of the PLC. The contacts used for the PLC's exterior output will act according to the device's response delay time.

When use this input/output format in a batch, the drive time and operation cycle of input filter and output device will also appear response delay.

《Not accept narrow input pulse signal》

PLC's input ON/OFF time should be longer than its loop time. If consider input filter's response delay 10ms, loop time is 10ms, then ON/OFF time needs 20 ms separately. So, up to 1, 000/ (20+20) =25Hz input pulse can't be disposed. But, this condition could be improved when use PLC's special function and applied instructions.

《Dual output (Dual coils) action》

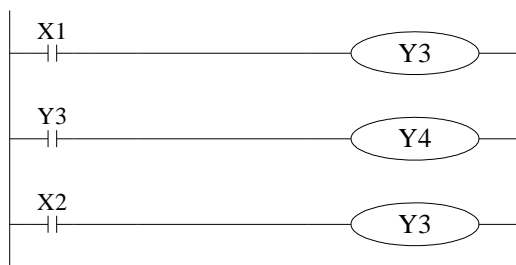

As shown in the left map, please consider the things of using the same coil Y003 at many positions:

E.g. X001=ON, X002=OFF

At first, X001 is ON, its image area is ON, output Y004 is also ON.

But, as input X002 is OFF, the image area of Y003 is OFF.

When executing dual output (use dual coil), the back side act in prior

So, the actual output is : Y003=OFF, Y004= ON.

4. Basic Program Instructions

In this chapter, we tell some basic instructions and their functions.

4-1. List of Basic Instructions

4-2. **【LD】** , **【LDI】** , **【OUT】**

4-3. **【AND】** , **【ANI】**

4-4. **【OR】** , **【ORI】**

4-5. **【LDP】** , **【LDF】** , **【ANDP】** , **【ANDF】** , **【ORP】** , **【ORF】**

4-6. Compare Instructions

4-7. **【ORB】**

4-8. **【ANB】**

4-9. **【MCS】** , **【MCR】**

4-10. **【ALT】**

4-11. **【PLS】** , **【PLF】**

4-12. **【SET】** , **【RST】**

4-13. **【OUT】** , **【RST】** (Compare with counter's soft unit)

4-14. **【NOP】** , **【END】**

4-15. Note Items When Programming



4-1. List of Basic Instructions

XC1、XC3、XC5 series basic SFC instructions

Mnemonic	Function	Format and Device
LD (LoaD)	Initial logical operation contact type NO (normally open)	X、Y、M、S、T、C、Dn.m、FDn.m
LDI (LoaD Inverse)	Initial logical operation contact type NC (normally closed)	X、Y、M、S、T、C、Dn.m、FDn.m
LDP (LoaD Pulse)	Initial logical operation-Rising edge pulse	X、Y、M、S、T、C、Dn.m、FDn.m
LDF (LoaD Falling Pulse)	Initial logical operation-Falling /trailing edge pulse	X、Y、M、S、T、C、Dn.m、FDn.m
AND (AND)	Serial connection of NO (normally open) contacts	X、Y、M、S、T、C、Dn.m、FDn.m
ANI (AND Inverse)	Serial connection of NC (normally closed) contacts	X、Y、M、S、T、C、Dn.m、FDn.m
ANDP (AND Pulse)	Serial connection of rising edge pulse	X、Y、M、S、T、C、Dn.m、FDn.m
ANDF (AND Falling pulse)	Serial connection of falling/trailing edge pulse	X、Y、M、S、T、C、Dn.m、FDn.m
OR (OR)	Parallel connection of NO (normally open) contacts	X、Y、M、S、T、C、Dn.m、FDn.m
ORI (OR Inverse)	Parallel connection of NC (normally closed) contacts	X、Y、M、S、T、C、Dn.m、FDn.m
ORP (OR Pulse)	Parallel connection of rising edge pulse	X、Y、M、S、T、C、Dn.m、FDn.m
ORF (OR Falling pulse)	Parallel connection of falling/trailing edge pulse	X、Y、M、S、T、C、Dn.m、FDn.m
ANB (ANd Block)	Serial connection of multiply parallel circuits	None
ORB (OR Block)	Parallel connection of multiply parallel circuits	None
OUT (OUT)	Final logic operation type coil drive	Y、M、S、T、C、Dn.m
SET (SET)	Set a bit device permanently ON	Y、M、S、T、C、Dn.m
RST (ReSeT)	Reset a bit device permanently OFF	Y、M、S、T、C、Dn.m
PLS (PuLSe)	Rising edge pulse	X、Y、M、S、T、C、Dn.m
PLF (PuLse Falling)	Falling/trailing edge pulse	X、Y、M、S、T、C、Dn.m

MCS (New bus line start)	Connect the public serial contacts	None
MCR (Bus line return)	Clear the public serial contacts	None
ALT (Alternate state)	The status of the assigned device is inverted on every operation of the instruction	X、Y、M、S、T、C、Dn.m
NOP (No Operation)	No operation or null step	None
END (END)	Force the current program scan to end	None

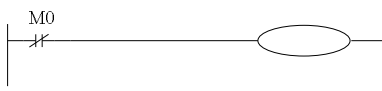
4-2. 【LD】 , 【LDI】 , 【OUT】

Mnemonic	Mnemonic	Function	Format and Devices
LD (LoaD)	LD	Initial logic operation contact type NO (Normally Open)	 Devices: X、Y、M、S、T、C、 Dn.m、FDn.m
LDI (LoaD Inverse)	LDI	Initial logic operation contact type NC (Normally Closed)	 Devices: X、Y、M、S、T、C、Dn.m、 FDn.m
OUT (OUT)	OUT	Final logic operation type drive coil	 Devices: X、Y、M、S、T、C、Dn.m、 FDn.m

Statement

- Connect the LD and LDI instructions directly to the left bus bar. Or use them to define a new block of program when using ANB instruction.
- OUT instruction is the coil drive instruction for the output relay、 auxiliary relay、 status、 timer、 counter. For the input relay, cannot use.
- Can not sequentially use parallel OUT command for many times.
- For the timer's time coil or counter's count coil, after using OUT instruction, set constant K is necessary.
- For the constant K's set bound、 actual timer constant、 program's step relative to OUT instruction (include the set value)

See the following table

Timer/Counter	Setting bound of K	The actual set value
1ms timer	1~32,767	0.001~32.767 seconds
10ms timer		0.01~32.767 seconds
100ms timer		0.1~32.767 seconds
16 bits counter	1~32,767	Same as the left
32 bits counter	1~2,147,483,647	Same as the left

Program

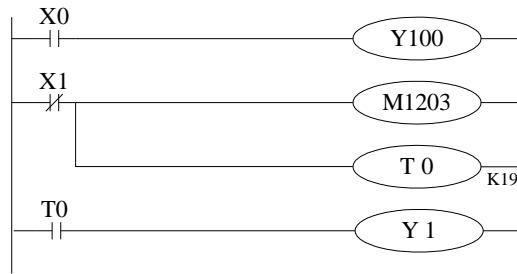



```

LD    X0
OUT   Y100
LDI   X1
OUT   M1203
OUT   T0
SP    K19
LD    T0
OUT   Y1
    
```

4-3. 【AND】 , 【ANI】

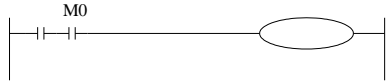
Mnemonic

Mnemonic	Function	Format and Devices
AND (AND)	Serial connection of NO (Normally Open) contacts	 Devices: X、Y、M、S、T、C、Dn.m、FDn.m
ANI (ANd Inverse)	Serial connection of NC (Normally Closed) contacts	 Devices: X、Y、M、S、T、C、Dn.m、FDn.m

Description

- Use the AND and ANI instructions for serial connection of contacts. As many contacts as required can be connected in series. They can be used for many times.
- The output processing to a coil, through writing the initial OUT instruction is called a “follow-on” output (For an example see the program below: OUT M2 and OUT Y003). Follow-on outputs are permitted repeatedly as long as the output order is correct. There’s no limit for the serial connected contacts’ No. and follow-on outputs’ number.

Program

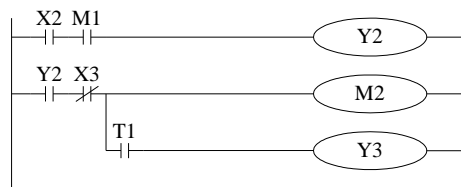

```
LD X2
AND M1
OUT Y2
LD Y2
ANI X3
OUT M2
AND T1
OUT Y3
```

4-4. 【OR】 , 【ORI】

Mnemonic and Function

Mnemonic	Function	Format and Devices
OR (OR)	Parallel connection of NO (Normally Open) contacts	<p>Devices: X、Y、M、S、T、C、Dn.m、FDn.m</p>
ORI (OR Inverse)	Parallel connection of NC (Normally Closed) contacts	<p>Devices: X、Y、M、S、T、C、Dn.m、FDn.m</p>

Description

- Use the OR and ORI instructions for parallel connection of contacts. To connect a block that contains more than one contact connected in series to another circuit block in parallel, use an ORB instruction.
- OR and ORI start from the instruction's step, parallel connect with the LD and LDI instruction's step said before. There is no limit for the parallel connect times.

Program

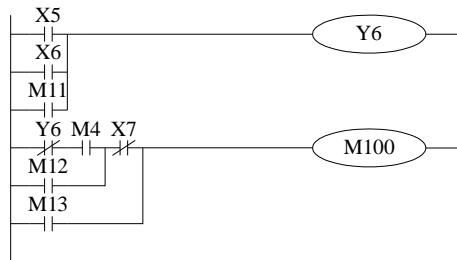

```

LD    X5
OR    X6
OR    M11
OUT   Y6
LDI   Y6
AND   M4
OR    M12
ANI   X7
OR    M13
OUT   M100
    
```

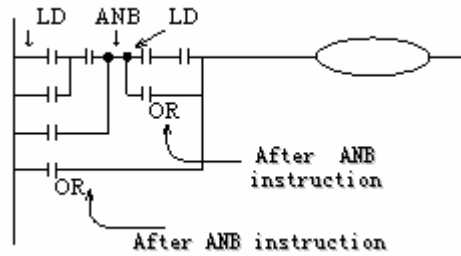

Relationship with ANB



The parallel connection with OR, ORI instructions should connect with LD, LDI instructions in principle. But after the ANB instruction, it's available to add a LD or LDI instruction.

4-5. 【LDP】 , 【LDF】 , 【ANDP】 , 【ANDF】 , 【ORP】 , 【ORF】

Mnemonic and Function

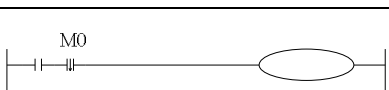
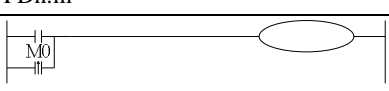
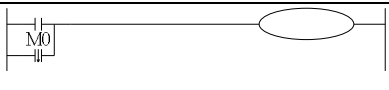
Mnemonic	Function	Format and Devices
LDP (LoaD Pulse)	Initial logical operation-Rising edge pulse	 Devices: X、Y、M、S、T、C、Dn.m、FDn.m
LDF (LoaD Falling pulse)	Initial logical operation Falling/trailing edge pulse	 Devices: X、Y、M、S、T、C、Dn.m、FDn.m
ANDP (AND Pulse)	Serial connection of Rising edge pulse	 Devices: X、Y、M、S、T、C、Dn.m、FDn.m
ANDF (AND Falling pulse)	Serial connection of Falling/trailing edge pulse	 Devices: X、Y、M、S、T、C、Dn.m、FDn.m
ORP (OR Pulse)	Parallel connection of Rising edge pulse	 Devices: X、Y、M、S、T、C、Dn.m、FDn.m
ORF (OR Falling pulse)	Parallel connection of Falling/trailing edge pulse	 Devices: X、Y、M、S、T、C、Dn.m、FDn.m

Description

- LDP、ANDP、ORP are active for one program scan after the associated devices switch from OFF to ON.
- LDF、ANDF、ORF are active for one program scan after the associated devices switch from ON to OFF.

Program



```

LDP   X5
ORP   X6
OUT   M13
LD    M8000
ANDP  X7
OUT   M15
    
```

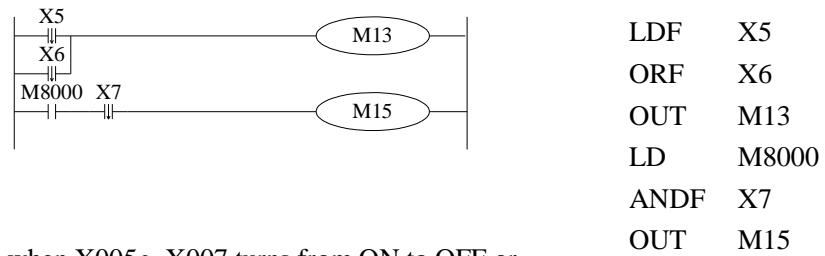

In the preceding chart, when X005~X007 turns from ON to OFF or from OFF to ON, M13 or M15 has only one scan cycle activates.

Output drive

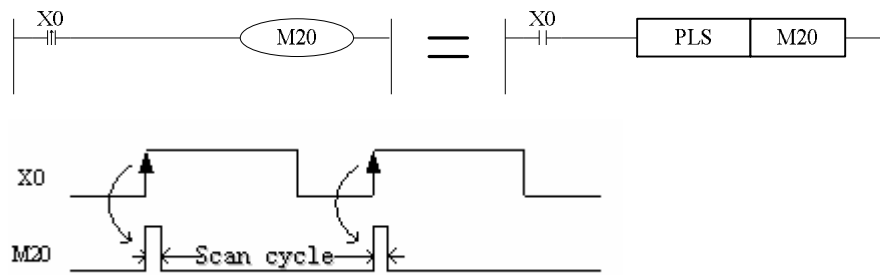

In two conditions, when X0 turns from OFF to ON, M20 gets a scan cycle.

NOTE:

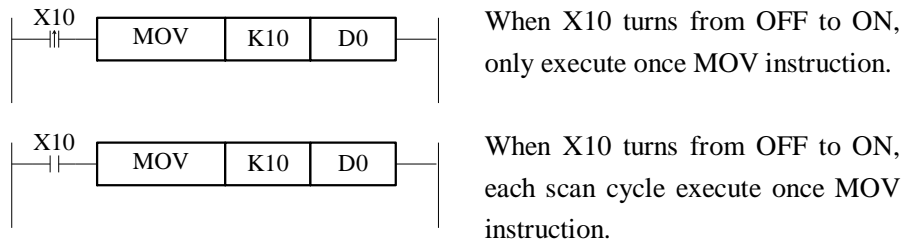

4-7. 【ORB】

Mnemonic and Function

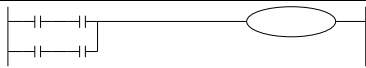
Mnemonic	Function	Format and Devices
ORB (OR Block)	Parallel connection of multiply parallel circuits	 Devices: none

Description

- To declare the starting point of the circuit (usually serial circuit blocks) to the preceding circuit in parallel. Serial circuit blocks are those in which more than one contacts in series or the ANB instruction is used.
- An ORB instruction is an independent instruction and is not associated with any device number.
- There are no limitations to the number of parallel circuits when using an ORB instruction in the sequential processing configuration.
- When using ORB instructions in a batch, use no more than 8 LD and LDI instructions in the definition of the program blocks (to be connected parallel).

Program

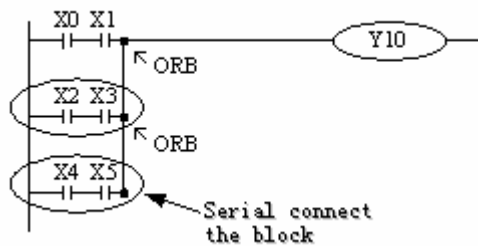

Recommended sequential programming method:

```
LD    X0
AND   X1
LD    X2
AND   X3
ORB
LDI   X4
AND   X5
ORB
```

Non-preferred batch programming method:

```
LD    X0
AND   X1
LD    X2
AND   X3
LDI   X4
AND   X5
ORB
```

4-8. 【ANB】

Mnemonic

Mnemonic	Function	Format and Devices
ANB (ANd Block)	Serial connection of multiply parallel circuits	 Devices: none

Description

- To declare the starting point of the circuit block, use a LD or LDI instruction. After completing the parallel circuit block, connect it to the preceding block in series using the ANB instruction.
- It is possible to use as many ANB instructions as necessary to connect a number of parallel circuit blocks to the preceding block in series. When using ANB instructions in a batch, use no more than 8 LD and LDI instructions in the definition of the program blocks (to be connected in parallel)

Program

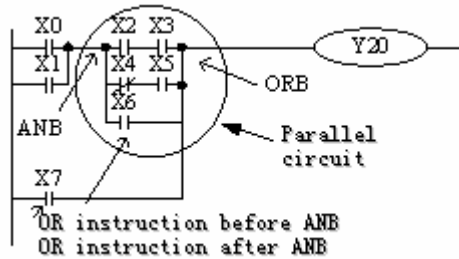



```

LD    X0
OR    X1
LD    X2           Start of a branch
AND   X3
LDI   X4           Start of a branch
AND   X5
ORB
OR    X6           End of a parallel circuit block
ANB
OR    X7           End of a parallel circuit block
OUT   Y20         Serial connect with the preceding circuit
    
```

4-9. 【MCS】 , 【MCR】

Mnemonic

Mnemonic	Function	Format and Devices
MCS (Master control)	Denotes the start of a master control block	 Devices: None
MCR (Master control Reset)	Denotes the end of a master control block	 Devices: None

Description

- After the execution of an MCS instruction, the bus line (LD, LDI) shifts to a point after the MCS instruction. An MCR instruction returns this to the original bus line.
- MCS、MCR instructions should use in pair.
- The bus line could be used nesting. Between the matched MCS、MCR instructions use matched MCS、MCR instructions. The nest level increase with the using of MCS instruction. The max nest level is 10. When executing MCR instruction, go back to the upper bus line.
- When use flow program, bus line management could only be used in the same flow. When end some flow, it must go back to the main bus line.

Description

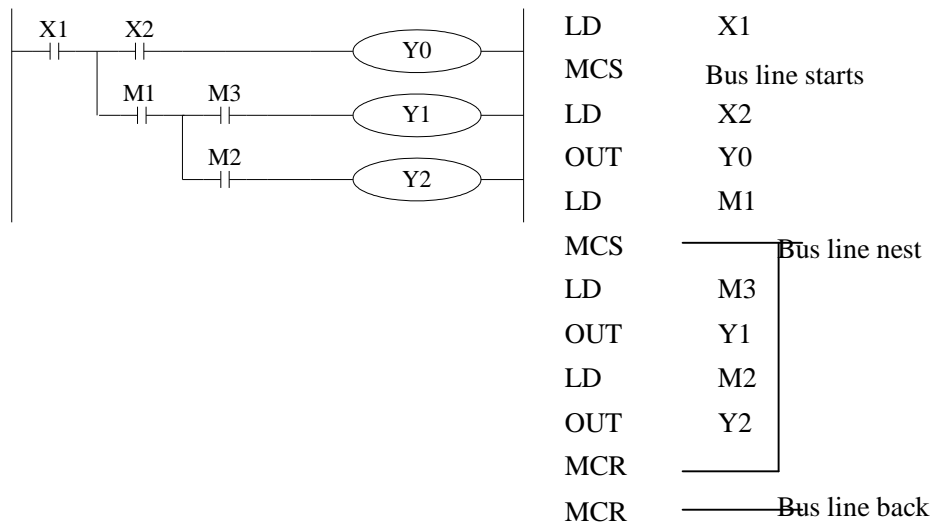

4-10. 【ALT】

Mnemonic and Function

Mnemonic	Function	Format and Devices
ALT (Alternate status)	The status of the assigned devices inverted on every operation of the instruction	 Devices: Y、M、S、T、C、Dn.m

Description

The status of the destination device is alternated on every operation of the ALT instruction.

Program

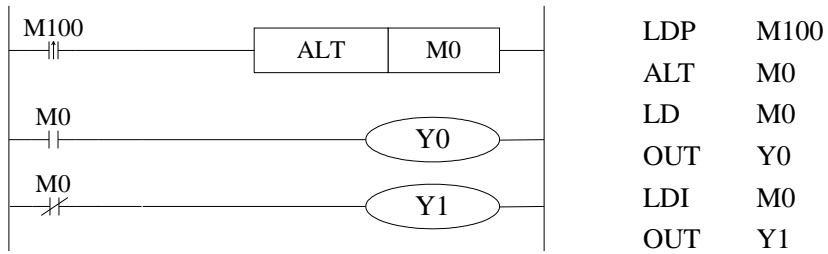

4-11. 【PLS】 , 【PLF】

Mnemonic and Function

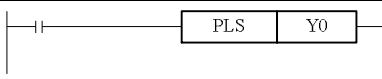
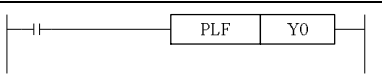
Mnemonic	Function	Format and Devices
PLS (PuLSe)	Rising edge pulse	 Devices: Y、M、S、T、C、Dn.m
PLF (PuLse Falling)	Falling/trailing edge pulse	 Devices: Y、M、S、T、C、Dn.m

Description

- When a PLS instruction is executed, object devices Y and M operate for one operation cycle after the drive input signal has turned ON.
- When a PLF instruction is executed, object devices Y and M operate for one operation cycle after the drive input signal has turned OFF.

Program

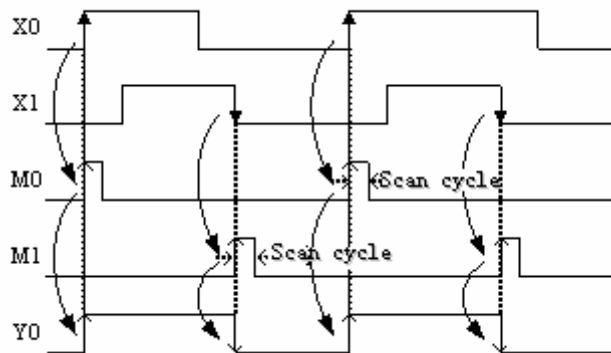
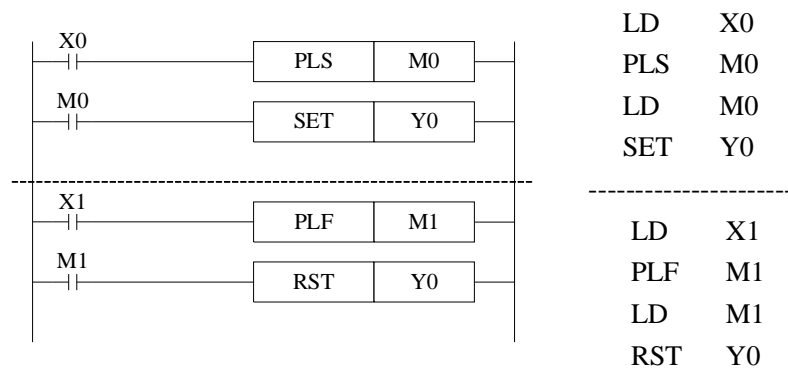

4-12. 【SET】 , 【RST】

Mnemonic and Function

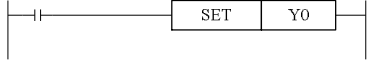
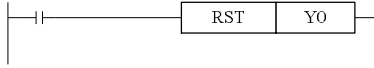
Mnemonic	Function	Format and Devices
SET (SET)	Set a bit device permanently ON	 Devices: Y、M、S、T、C、Dn.m
RST (ReSeT)	Reset a bit device permanently OFF	 Devices: Y、M、S、T、C、Dn.m

Description

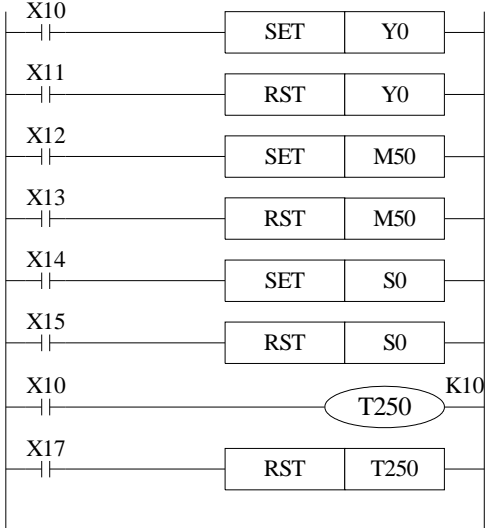
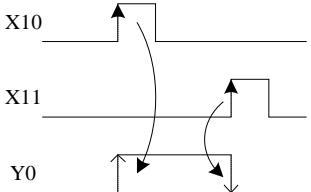

- Turning ON X010 causes Y000 to turn ON. Y000 remains ON even after X010 turns OFF. Turning ON X011 causes Y000 to turn OFF. Y000 remains OFF even after X011 turns OFF. It's the same with M、S.
- SET and RST instructions can be used for the same device as many times as necessary. However, the last instruction activated determines the current status.
- After assign the start definition ID and end definition ID, operate the operands in one bound at the same time is available.
- Besides, it's also possible to use RST instruction to reset the current contents of timer, counter and contacts.

Program

	<pre style="font-family: monospace;"> LD X10 SET Y0 LD X11 RST Y0 LD X12 SET M50 LD X13 RST M50 LD X14 SET S0 LD X15 RST S0 LD X10 SET T250 LD X17 RST T250 </pre>
	

4-13. 【OUT】 , 【RST】 for the counters

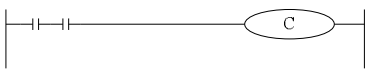
Mnemonic and Function

Mnemonic	Function	Format and Devices
OUT (OUT)	Final logic operation type coil drive	 K or D
RST (ReSeT)	Reset a bit device permanently OFF	

Programming

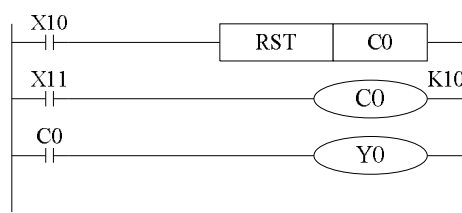

C0 carries on increase count for the OFF→ON of X011. When reach the set value K10, output contact C0 activates. Afterwards, even X011 turns from OFF to ON, counter's current value will not change, output contact keep on activating.

Counter used for power cut retentive. Even when power is cut, hold the current value and output contact's action status and reset status.

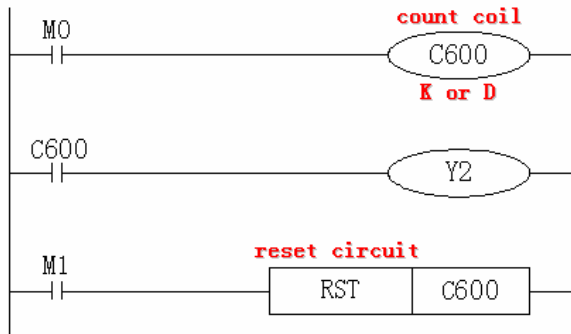

To clear this, let X010 be the activate status and reset the output contact. It's necessary to assign constant K or indirect data register's ID behind OUT instruction.

Programming of high speed counter



- In the preceding example, when M0 is ON, carry on positive count with OFF→ON of X0.
- Counter's current value increase, when reach the set value (K or D), the output contact is reset.
- When M1 is ON, counter's C600 output contact is reset, counter's current value turns to be 0.

4-14. 【NOP】 , 【END】

Mnemonic	Function	Format and Devices: None
NOP (No Operation)	No operation or null step	 Devices: None
END (END)	Force the current program scan to end	 Devices: None

Description

- When clear the whole program, all the instructions become NOP. If add NOP instructions between the common instructions, they have no effect and PLC will keep on working. If add NOP instructions in the program, then when modify or add programs, the step vary will be decreased. But the program should have rest quantity.
- If replace the program's instructions with NOP instructions, then the

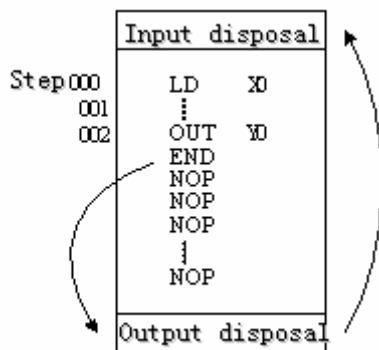
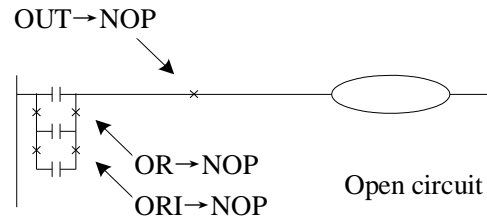
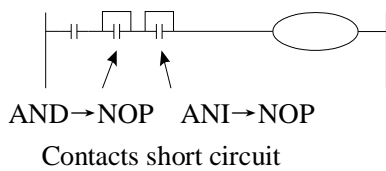

PLC repeatedly carry on input disposal, program executing and output disposal. If write END instruction at the end of the program, then the instructions behind END instruction won't be executed. If there's no END instruction in the program, the PLC executes the end step and then repeat executing the program from step 0.

When debug, insert END in each program segment to check out each program's action.

Then, after confirm the correction of preceding block's action, delete END instruction.

Besides, the first execution of RUN begins with END instruction.

When executing END instruction, refresh monitor timer. (Check if scan cycle is a long timer.)

4-15. Items To Note When Programming

1、Contacts' structure and step number

Even in the sequential control circuit with the same action, it's also available to simple the program and save program's steps according to the contacts' structure. General program principle is: a) write the circuit with many serial contacts on the top; b) write the circuit with many parallel contacts in the left.

2、Program's executing sequence

Handle the sequential control program by 【From top to bottom】 and 【From left to right】 Sequential control instructions also encode following this flow.

3、Dual output dual coil's activation and the solution

- If carry on coil's dual output (dual coil) in the sequential control program, then the backward action is prior.
- Dual output (dual coil) doesn't go against the input rule at the program side. But as the preceding action is very complicate, please modify the program as in the following example.

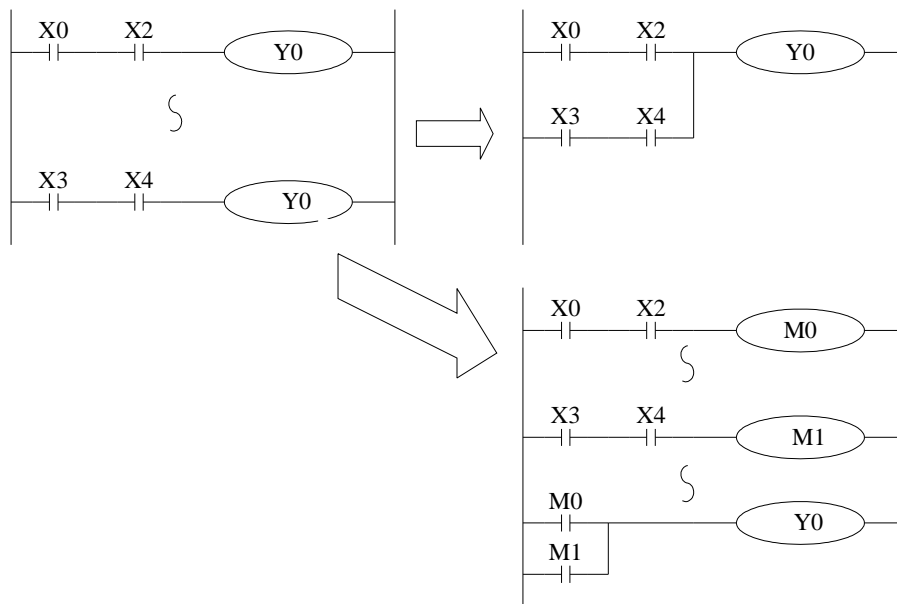

There are other methods. E.g. jump instructions or step ladder. However, when use step ladder, if the main program's output coil is programmed, then the disposal method is the same with dual coil, please note this.

Memo

5. Applied Instructions

In this chapter, we describe applied instruction's function of XC series PLC.

5-1. Table of Applied Instructions

5-2. Reading Method of Applied Instructions

5-3. Flow Instructions

5-4. Contactors Compare Instructions

5-5. Move and Compare Instructions

5-6. Arithmetic and Logic Operation Instructions

5-7. Loop and Shift Instructions

5-8. Data Convert

5-9. Floating Operation

5-10. Clock Operation

5-1. Applied Instruction List

The applied instructions' sort and their correspond instructions are listed in the following table:

Common statements of XC1/XC3/XC5:

Sort	Mnemonic	Function
Program Flow	CJ	Condition jump
	CALL	Call subroutine
	SRET	Subroutine return
	STL	Flow start
	STLE	Flow end
	SET	Open the assigned flow, close the current flow
	ST	Open the assigned flow, not close the current flow
	FOR	Start of a FOR-NEXT loop
	NEXT	End of a FOR-NEXT loop
	FEND	First end
Data Compare	LD=	LD activates if (S1) = (S2)
	LD>	LD activates if (S1) > (S2)
	LD<	LD activates if (S1) < (S2)
	LD<>	LD activates if (S1) ≠ (S2)
	LD<=	LD activates if (S1) ≤ (S2)
	LD>=	LD activates if (S1) ≥ (S2)
	AND=	AND activates if (S1) = (S2)
	AND>	AND activates if (S1) > (S2)
	AND<	AND activates if (S1) < (S2)
	AND<>	AND activates if (S1) ≠ (S2)
	AND<=	AND activates if (S1) ≤ (S2)
	AND>=	AND activates if (S1) ≥ (S2)
	OR=	OR activates if (S1) = (S2)
	OR>	OR activates if (S1) > (S2)
	OR<	OR activates if (S1) < (S2)
	OR<>	OR activates if (S1) ≠ (S2)
	OR<=	OR activates if (S1) ≤ (S2)
OR>=	OR activates if (S1) ≥ (S2)	
Data Move	MOV	Move
	BMOV	Block move
	FMOV	Fill move
	FWRT	FlashROM written
	MSET	Zone set
	ZRST	Zone reset

	SWAP	The high and low byte of the destinated devices are exchanged
	XCH	Exchange
Data Operation	ADD	Addition
	SUB	Subtraction
	MUL	Multiplication
	DIV	Division
	INC	Increment
	DEC	Decrement
	MEAN	Mean
	WAND	Word And
	WOR	Word OR
	WXOR	Word exclusive OR
	CML	Compliment
	NEG	Negative

Common statements of XC3/XC5

Data Shift	SHL	Arithmetic Shift Left
	SHR	Arithmetic Shift Right
	LSL	Logic shift left
	LSR	Logic shift right
	ROL	Rotation shift left
	ROR	Rotation shift right
	SFTL	Bit shift left
	SFTR	Bit shift right
	WSFL	Word shift left
	WSFR	Word shift right
Data Convert	WTD	Single word integer converts to double word integer
	FLT	32 bits integer converts to float point
	FLTD	64 bits integer converts to float point
	INT	Float point converts to binary
	BIN	BCD converts to binary
	BCD	Binary converts to BCD
	ASC	Hex. converts to ASCII
	HEX	ASCII converts to Hex.
	DECO	Coding
	ENCO	High bit coding
ENCOL	Low bit coding	
Float Point Operation	ECMP	Float compare
	EZCP	Float Zone compare
	EADD	Float Add
	ESUB	Float Subtract
	EMUL	Float Multiplication
	EDIV	Float division
	ESQR	Float Square Root
	SIN	Sine
	COS	Cosine
TAN	Tangent	
Clock Operation	TCMP	Time Compare
	TZCP	Time Zone Compare
	TADD	Time Add
	TSUB	Time Subtract
	TRD	Read RTC data
	TWR	Set RTC data

5-2. Reading Method of Applied Instructions

Understanding method of instruction understanding

In this manual, the applied instructions are described in the following manner.

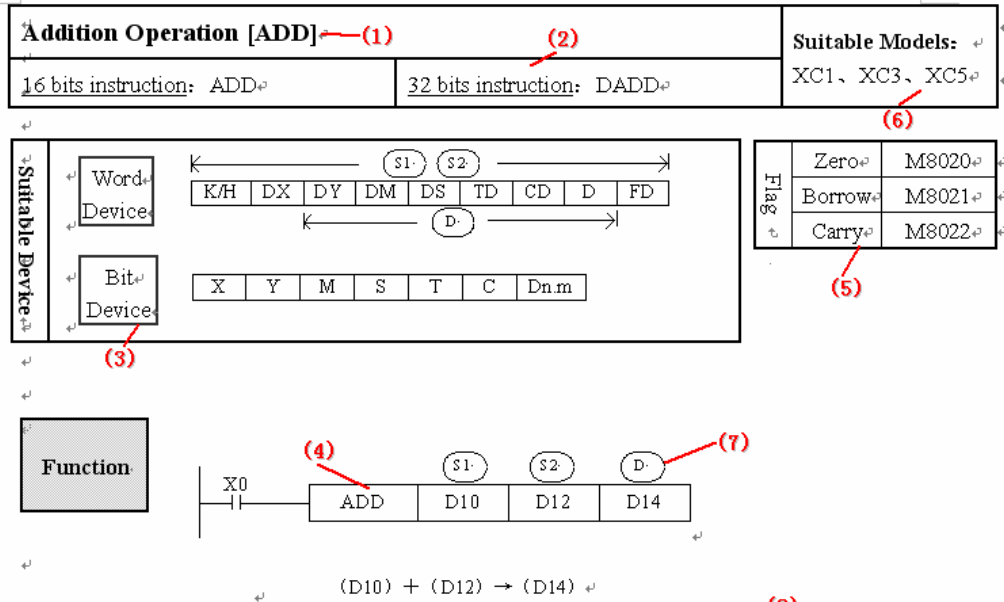

- The data contained within the two source devices are combined and the total is stored in the specified destination device. Each data's highest bit is the sign bit, 0 stands for positive, 1 stands for negative. All calculations are algebraic processed. (5+ (-8) =-3)
- If the result of a calculation is "0", the "0" flag acts. If the result exceeds 323, 767 (16 bits limit) or 2,147,483,647 (32 bits limit), the carry flag acts. (refer to the next page). If the result exceeds -323,768 (16 bits limit) or -2,147,483,648 (32 bits limit), the borrow flag acts (Refer to the next page)
- When carry on 32 bits operation, word device's low 16 bits are assigned, the device following closely the preceding device's ID will be the high bits. To avoid ID repetition, we recommend you assign device's ID to be even ID.
- The same device may be used as a source and a destination. If this is the case then the result changes after every scan cycle. Please note this point.

Note:

- ① Denote the instruction name
- ② 16 bits instruction and 32 bits instruction
- ③ Denotes the soft units which can be used as the operation object
- ④ Ladder Example
- ⑤ Flag after executing the instruction. Instructions without the direct flag will not display.
- ⑥ Suitable models for the instruction
- ⑦ (S?) Source operand, its content won't change after executing the instruction
(D?) Destinate operand, its content changes with the execution of the instruction
- (8) Tell the instruction's basic action, using way, applied example, extend function, note items etc.

The related description

- The assignment of the data

The data register of XC series PLC is a single word (16 bit) data register, single word data only engross one data register which is assigned by single word object instruction. The disposal bound is: Dec. -327,68~327,67, Hex. 0000~FFFF.

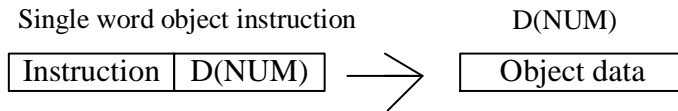

Double word(32 bit)engrosses two data register, it's composed by two consecutive data registers, the first one is assigned by double word object instruction. The dispose bound is: Dec. -214,748,364,8~214,748,364,7, Hex. 00000000~FFFFFFFF.

Double word object instruction

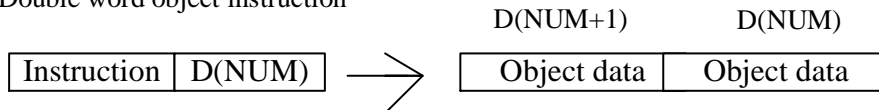

- The denote way of 32 bits instruction

If an instruction can not only be 16 bits but also be 32 bits, then the denote method for 32 bits instruction is to add a “D” before 16 bits instruction.

E.g: ADD D0 D2 D4 denotes two 16 bits data adds;

DADD D10 D12 D14 denotes two 32 bits data adds

Instructions list of 16 bits and correspond 32 bits:

	16 bits	32 bits		16 bits	32 bits
Program Flow	CJ	-	Data convert	WTD	-
	CALL	-		FLT	DFLT
	SRET	-		INT	DINT
	STL	-		BIN	DBIN
	STLE			BCD	DBCD
	SET			ASC	-
	ST			HEX	-
	FOR	-		DECO	-
	NEXT	-		ENCO	-
	FEND	-		ENCOL	-
	Data Move	MOV		DMOV	Float operation
BMOV			-	EZCP	
FMOV		-	-	EADD	
FWRT		DFWRT	-	ESUB	
ZRST		-	-	EMUL	
SWAP		-	-	EDIV	
XCH		DXCH	-	ESQR	
Data operation	ADD	DADD	-	SIN	
	SUB	DSUB	-	COS	
	MUL	DMUL		TAN	
	DIV	DDIV	Clock operation	TCMP	
	INC	DINC		TZCP	-
	DEC	DDEC		TADD	-
	MEAN	DMEAN		TSUB	-
	WAND	DWAND		TRD	-
	WOR	DWOR		TWR	-
	WXOR	DWXOR			
	Data Shift	CML	DCML		
NEG		DNEG			
SHL		DSHL			
SHR		DSHR			
LSL		DLSL			
LSR		DLSR			
ROL		DROL			
ROR		DROR			
SFTL		DSFTL			
SFTR		DSFTR			
WSFL	DWSFL				
WSFR	DWSFR				

5-3. Program Flow Instructions

➤ Mnemonic	Instruction's name
CJ	Condition Jump
CALL	Call subroutine
SRET	Subroutine return
STL	Flow start
STLE	Flow end
SET	Open the assigned flow, close the current flow (flow jump)
ST	Open the assigned flow, not close the current flow (Open the new flow)
FOR	Start of a FOR-NEXT loop
NEXT	End of a FOR-NEXT loop
FEND	First End

Condition Jump [CJ]		Suitable Models: XC1、XC3、XC5
<u>16 bits instruction:</u> CJ	<u>32 bits instruction:</u> -	
Suitable Device	Pointer: P	
	Soft Unit's Bound: P0~P9999	

Function and Action

As the instructions of executing list, with CJ instructions, the operate cycle and dual coil can be greatly shorten.

In the following chart, if X000" ON", then jump from step 1 to the end step of flag P6. When X000" OFF" , do not execute jump instructions.

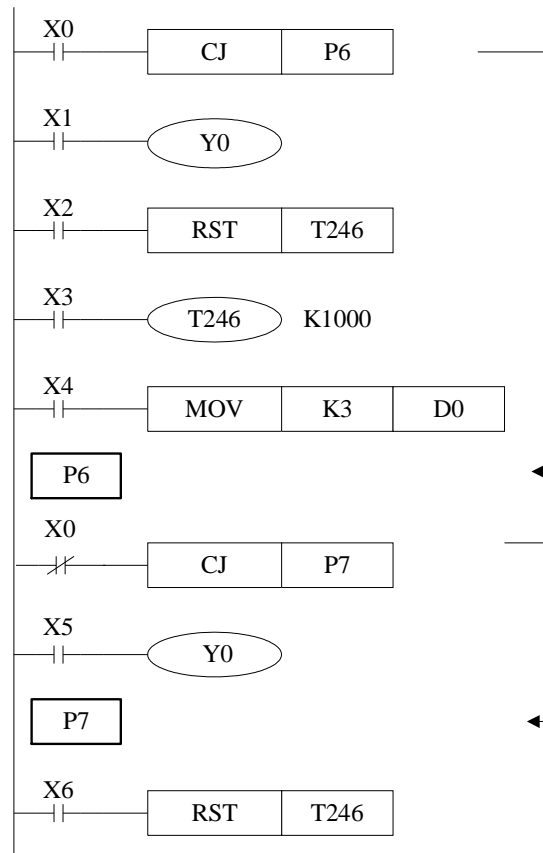

- See the upward graph, Y000 turns to be dual coil and output. But when X000=OFF, X001 activates. When X000=ON, X005 activates.
- CJ can not jump from one STL to another STL.
- If program timer T0~T640 and high speed counter C600~C640 jump after driving, go on working, output point also activate.

Call subroutine [CALL] and Subroutine return [SRET]		Suitable Models: XC1、XC3、XC5
<u>16 bits instruction:</u> CALL、SRET	<u>32 bits instruction:</u> -	

Suitable Device	Pointer: P Soft Unit's Bound: P0~P9999
------------------------	---

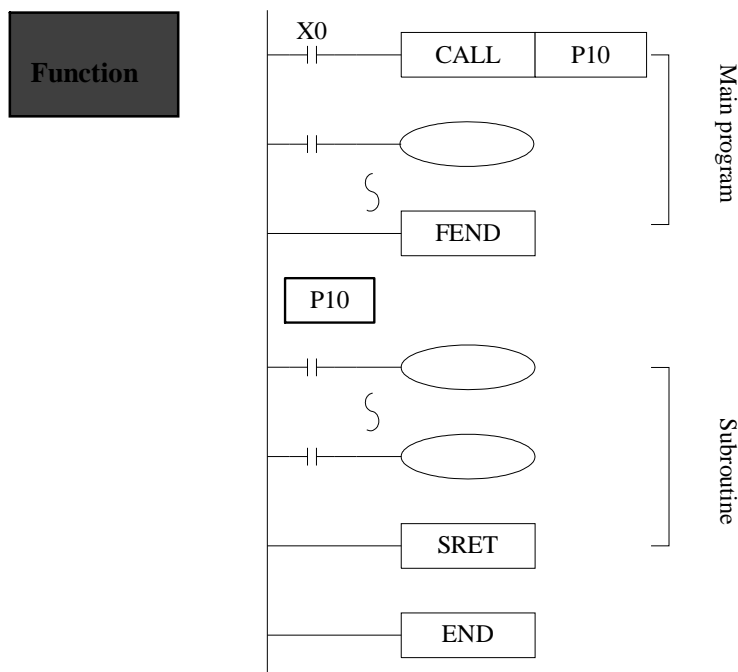

- If X000“ ON” , carry on Jump instruction and jump to step of flag P10. Here, after executing the subroutine, return to the original step via executing SRET instruction. After the following FEND instruction, program with the flag.
- In the subroutine, 9 levels Call instruction is allowed, so to the all, 10 levels nesting is available.

Flow [SET]、[ST]、[STL]、[STLE]		Suitable Models: XC1、XC3、XC5
<u>16 bits instruction:</u> SET、ST、STL、STLE	<u>32 bits instruction:</u> -	

Suitable Device	Pointer: S Soft Unit's Bound: S0~S
------------------------	---------------------------------------

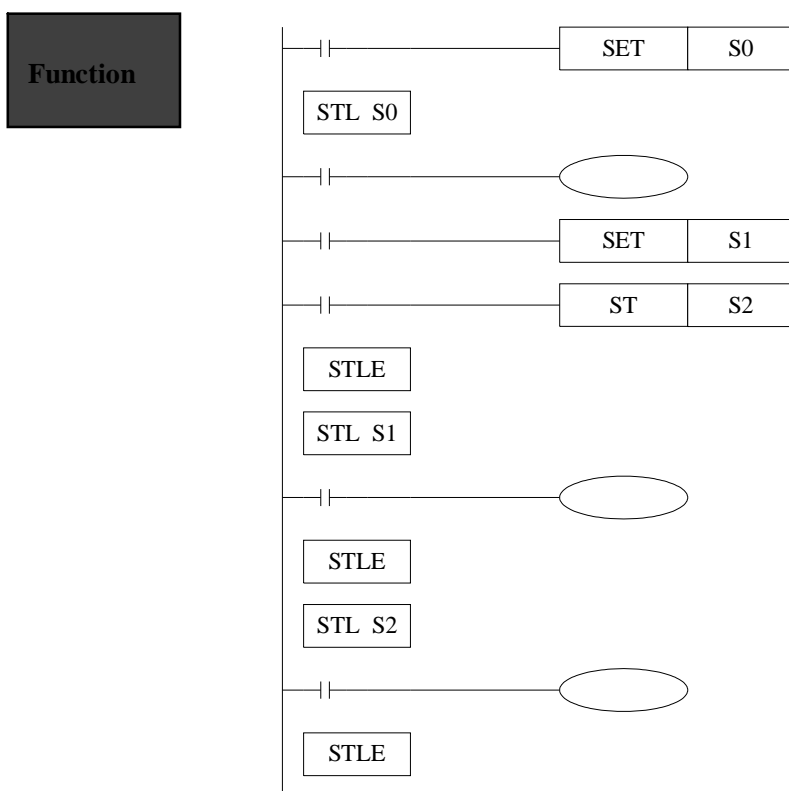

- STL and STLE should be used in pairs. STL means start of a flow, STLE means end of a flow.
- After executing of SET Sxxx instruction, the flow assigned by these instructions is ON.
- After executing RST Sxxx instruction, the assigned flow is OFF.
- In flow S0, SET S1 close the current flow S0, open flow S1.
- In flow S0, ST S2 open the flow S2, but don't close flow S0.
- When flow turns from ON to be OFF, OFF or reset OUT、PLS、PLF、not accumulate timer etc. which belongs to the flow.
- ST instruction is usually used when a program needs to run more flows at the same time.
- In a main program, usually use ST instruction to open a flow.

[FOR] AND [NEXT]		Suitable Models: XC1、XC3、XC5
<u>16 bits instruction:</u> FOR、NEXT	<u>32 bits instruction:</u> -	

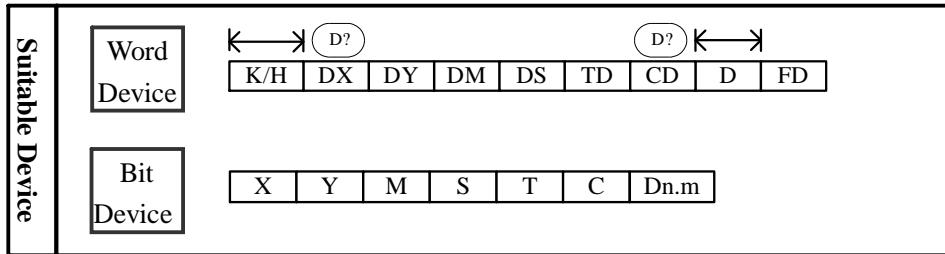

Function

First execute the instructions between FOR~NEXT instructions for several times (the loop time is assigned by the source data), then execute the steps after NEXT.

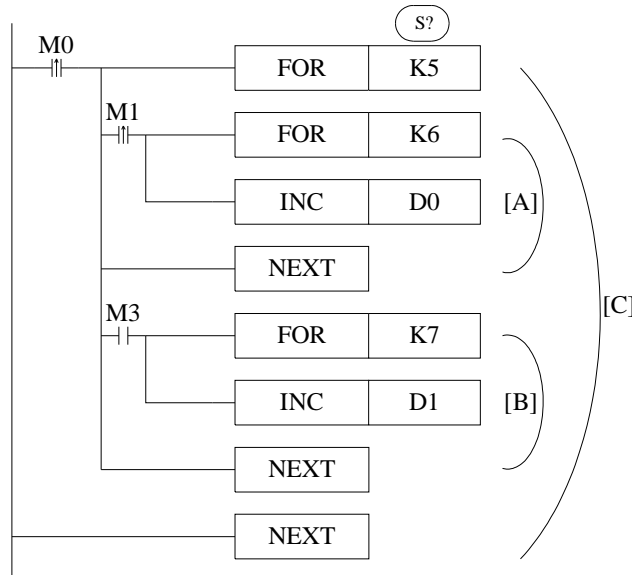

- FOR、NEXT instructions must be programmed as a pair. Nesting is allowed, and the nesting level is 8.
- Between FOR/NEXT, LDP、LDF instructions are effective for one time. Every time when M0 turns from OFF to ON, and M1 turns from OFF to ON, [A] loop is executed 6 times.
- Every time if M0 turns from OFF to ON and M3 is ON, [B] loop is executed 5? 7=35 times.
- If there are many loop times, the scan cycle will be prolonged. Monitor timer error may occur, please note this.
- If NEXT is before FOR, or no NEXT, or NEXT is behind FENG, END, or FOR and NEXT number is not equal, an error will occur.
- Between FOR~NEXT, CJ nesting is not allowed, also in one STL, FOR~NEXT must be programmed as a pair.

[FEND] AND [END]		Suitable Models: XC1、XC3、XC5
<u>16 bits instruction:</u> FEND、END	<u>32 bits instruction:</u> -	

Suitable Device	None
-----------------	------

Function

An FEND instruction indicates the first end of a main program and the start of the program area to be used for subroutines. Under normal operating circumstances the FEND instruction performs a similar action to the END instruction, i.e. output processing, input processing and watchdog timer refresh are all carried out on execution.

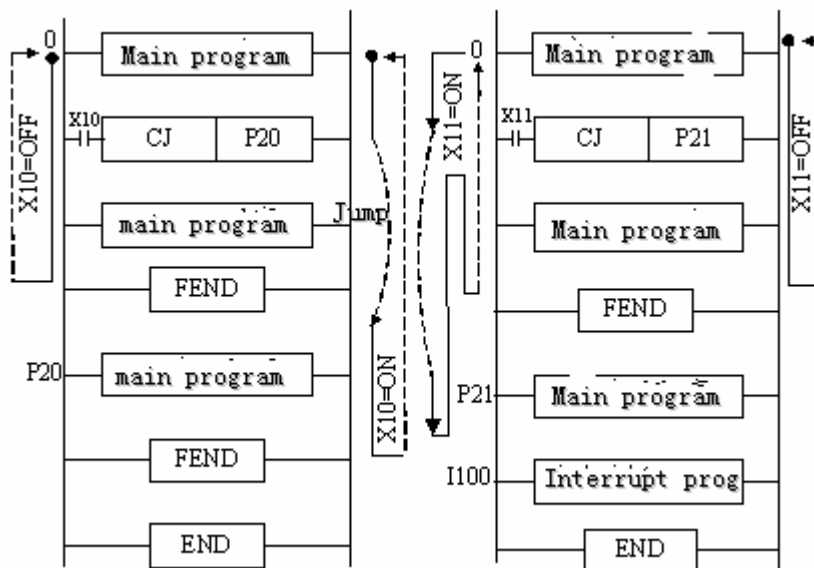

- If program the tag of CALL instruction behind FEND instruction, there must be SRET instruction. If the interrupt pointer program behind FEND instruction, there must be SRET instruction.
- After executing CALL instruction and before executing SRET instruction, if execute FEND instruction; or execute FEND instruction after executing FOR instruction and before executing NEXT, then an error will occur.
- In the condition of using many FEND instruction, please compile routine or subroutine between the last FEND instruction and END instruction.

5-4. Contactor's Compare Instructions

Mnemonic & Function

Mnemonic	➤ Function
LD=	Initial comparison contact. Active when the comparison $(S1)=(S2)$ is true.
LD>	Initial comparison contact. Active when the comparison $(S1)>(S2)$ is true
LD<	Initial comparison contact. Active when the comparison $(S1)<(S2)$ is true
LD<>	Initial comparison contact. Active when the comparison $(S1)\neq(S2)$ is true
LD<=	Initial comparison contact. Active when the comparison $(S1)\leq(S2)$ is true
LD>=	Initial comparison contact. Active when the comparison $(S1)\geq(S2)$ is true
AND=	Serial comparison contact. Active when the comparison $(S1)=(S2)$ is true.
AND>	Serial comparison contact. Active when the comparison $(S1)>(S2)$ is true.
AND<	Serial comparison contact. Active when the comparison $(S1)<(S2)$ is true.
AND<>	Serial comparison contact. Active when the comparison $(S1)\neq(S2)$ is true.
AND<=	Serial comparison contact. Active when the comparison $(S1)\leq(S2)$ is true.
AND>=	Serial comparison contact. Active when the comparison $(S1)\geq(S2)$ is true.
OR=	Parallel comparison contact. Active when the comparison $(S1)=(S2)$ is true.
OR>	Parallel comparison contact. Active when the comparison $(S1)>(S2)$ is true.
OR<	Parallel comparison contact. Active when the comparison $(S1)<(S2)$ is true.
OR<>	Parallel comparison contact. Active when the comparison $(S1)\neq(S2)$ is true.
OR<=	Parallel comparison contact. Active when the comparison $(S1)\leq(S2)$ is true.
OR>=	Parallel comparison contact. Active when the comparison $(S1)\geq(S2)$ is true.

Initial Comparison LD □		Suitable Models: XC1、XC3、XC5
<u>16 bits instruction:</u> Refer Below	<u>32 bits instruction:</u> Refer Below	

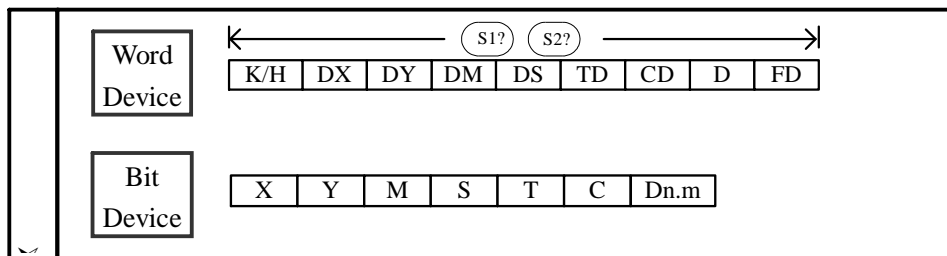

Instruction & Function

The value of S1 and S2 are tested according to the comparison of the instruction. If the comparison is true then the LD contact is active. If the comparison is false then the LD contact is not active.

16 bits	➤ 32 bits	➤ Active condition	➤ Inactive condition
LD =	DLD=	(S1) = (S2)	(S1) ≠ (S2)
LD >	DLD>	(S1) > (S2)	(S1) ≤ (S2)
LD <	DLD<	(S1) < (S2)	(S1) ≥ (S2)
LD <>	DLD<>	(S1) ≠ (S2)	(S1) = (S2)
LD <=	DLD<=	(S1) ≤ (S2)	(S1) > (S2)
LD >=	DLD>=	(S1) ≥ (S2)	(S1) < (S2)

Program

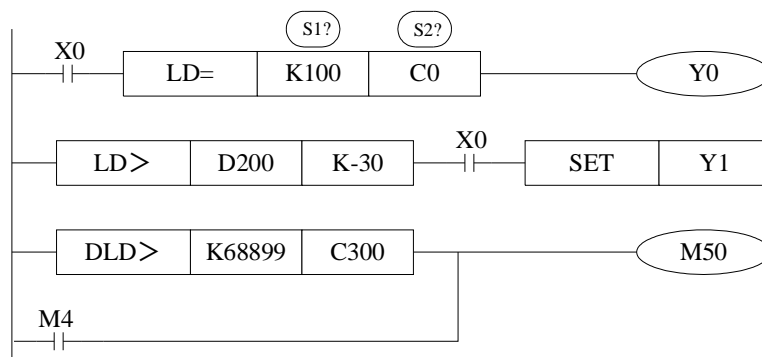

Note Items

- When the source data's highest bit (16 bits: b15, 32 bits: b31) is 1, use the data as a negative.
- The comparison of 32 bits counter (C300~) must use 32 bits instruction. If assigned as 16 bits instruction, it will lead the program error or operation error.

Serial Refer Below AND □		Suitable Models: XC1、XC3、XC5
16 bits instruction: Refer Below	32 bits instruction: Refer Below	

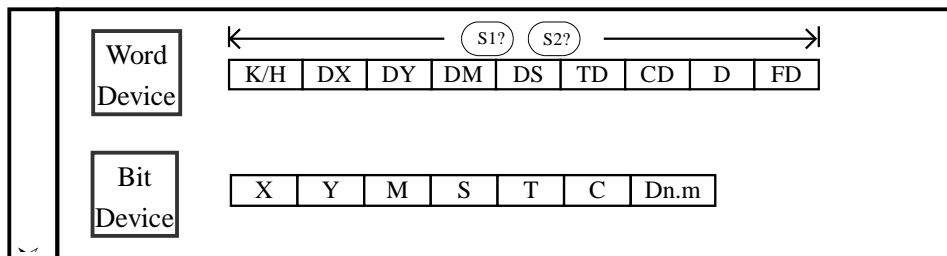

Instruction & Function

The value of S1 and S2 are tested according to the comparison of the instruction. If the comparison is true then the LD contact is active. If the comparison is false then the LD contact is not active.

16 bits	➤ 32 bits	➤ Active condition	➤ Inactive condition
AND =	DAND=	(S1) = (S2)	(S1) ≠ (S2)
AND >	DAND>	(S1) > (S2)	(S1) ≤ (S2)
AND <	DAND<	(S1) < (S2)	(S1) ≥ (S2)
AND <>	DAND<>	(S1) ≠ (S2)	(S1) = (S2)
	AND<=	(S1) ≤ (S2)	(S1) > (S2)
AND >=	DAND>=	(S1) ≥ (S2)	(S1) < (S2)

Program

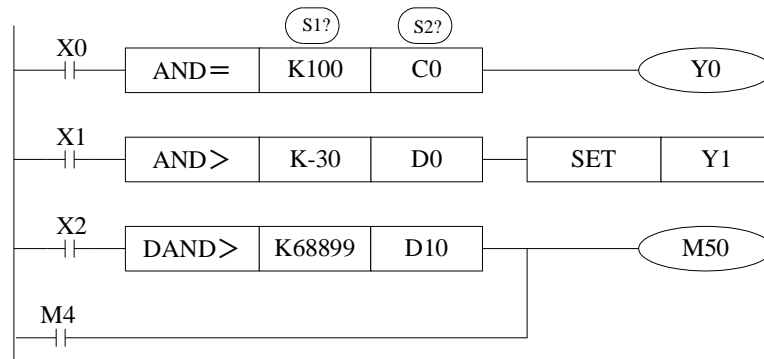

Note Items

- When the source data's highest bit (16 bits: b15, 32 bits: b31) is 1, use the data as a negative.
- The comparison of 32 bits counter (C300~) must use 32 bits instruction. If assigned as 16 bits instruction, it will lead the program error or operation error.

Parallel Comparison OR □		Suitable Models: XC1、XC3、XC5
16 bits instruction: Refer Below	32 bits instruction: Refer Below	

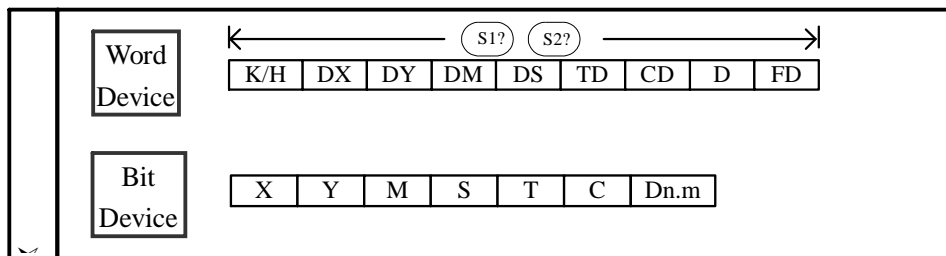

Instruction & Function

The value of S1 and S2 are tested according to the instruction. If the comparison is true then the AND contact is active. If the comparison is false then the AND contact is not active.

16 bits	32 bits	Active condition	Inactive condition
AND=	DAND=	(S1) = (S2)	(S1) ≠ (S2)
AND>	DAND>	(S1) > (S2)	(S1) ≤ (S2)
AND<	DAND<	(S1) < (S2)	(S1) ≥ (S2)
AND<>	DAND<>	(S1) ≠ (S2)	(S1) = (S2)
AND≤	DAND≤	(S1) ≤ (S2)	(S1) > (S2)
AND≥	DAND≥	(S1) ≥ (S2)	(S1) < (S2)

Program

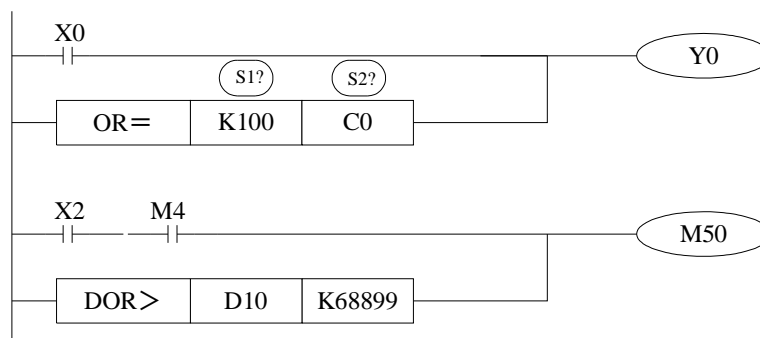

Note Items

- When the source data's highest bit (16 bits: b15, 32 bits: b31) is 1, use the data as a negative.
- The comparison of 32 bits counter (C300~) must be 32 bits instruction. If assigned as a 16 bits instruction, it will lead the program error or operation error.

5-5. Data Move

Mnemonic	Function
MOV	Move
BMOV	Block Move
FMOV	Fill Move
FWRT	Written of FlashROM
MSET	Zone Set
ZRST	Zone Reset
SWAP	Float To Scientific
XCH	Exchange

[MOV]		Suitable Models: XC1、XC3、XC5
<u>16 bits instruction:</u> MOV	<u>32 bits instruction:</u> DMOV	

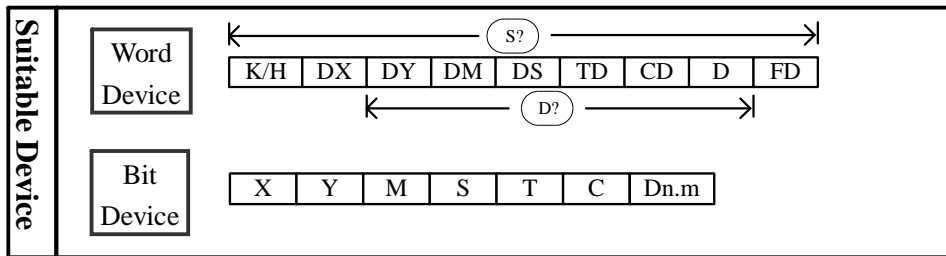

Function & Action

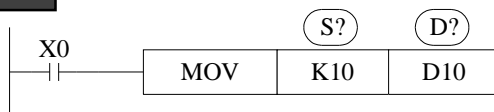

Move data from one storage area to a new one.

- Move contents from source to destination
- If X000 is OFF, data will not change.
- Constant K10 will automatically convert to be BIN code.

《Read out the current value of timer、 counter》

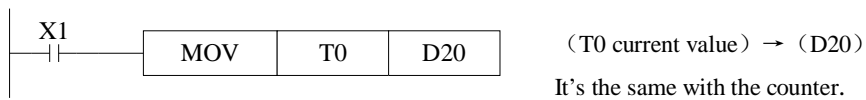

《Indirect assign the set value of timer、 counter》

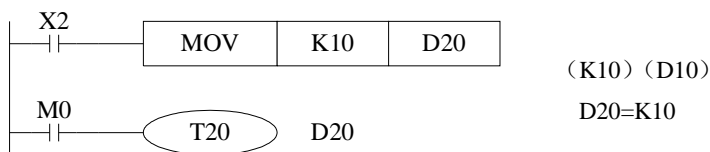

《Move of 32 bits data》

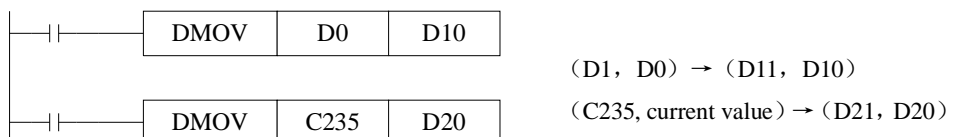

[BMOV]		Suitable Models: XC1、XC3、XC5
<u>16 bits instruction:</u> BMOV	<u>32bits instruction:</u> -	

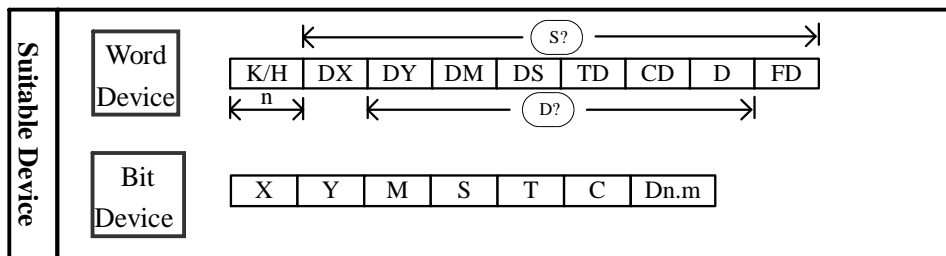

Function

- A quantity of consecutively occurring data elements can be copied to a new destination. The source data is identified as a device head address(S) and a quantity of consecutive data elements (n). This is moved to the destination device (D) for the same number of elements (n). (If the quantity of source device (n) exceeds the actual number of available source devices, then only those devices which fall in the available range will be used. If the number of source devices exceeds the available space at the destination location, then only the available destination devices will be written to.)

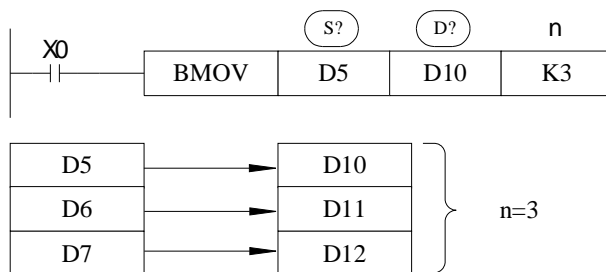

- The BMOV instruction has a built in automatic feature to prevent overwriting errors from occurring when the source (S-n) and destination (D-n) data ranges coincide. This is clearly identified in the following diagram:
- (NOTE: The numbered arrows indicate the order in which the BMOV is processed).

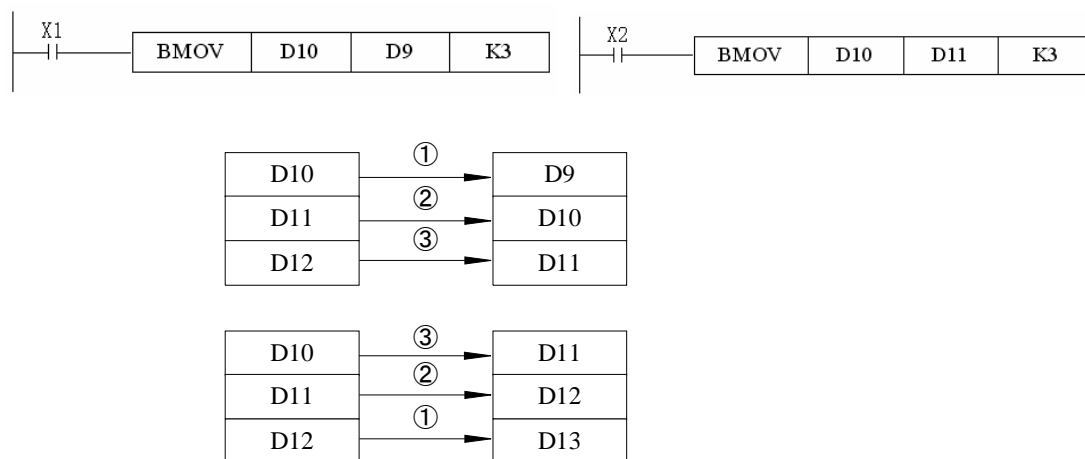

[FMOV]		Suitable Models: XC1、XC3、XC5
<u>16 bits instruction:</u> FMOV	<u>32 bits instruction:</u> -	

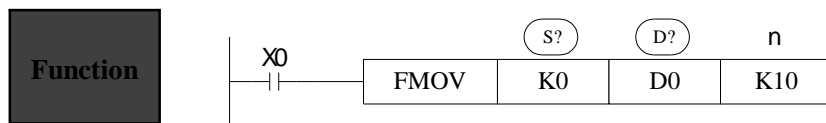
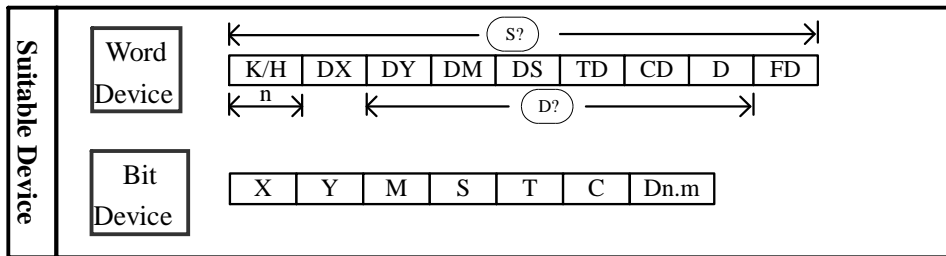

- Move K0 to D0~D9. Copy a single data device to a range of destination devices.
- The data stored in the source device (S) is copied to every device within the destination range, The range is specified by a device head address (D) and a quantity of consecutive elements (n).
- If the specified number of destination devices (n) exceeds the available space at the destination location, then only the available destination devices will be written to.

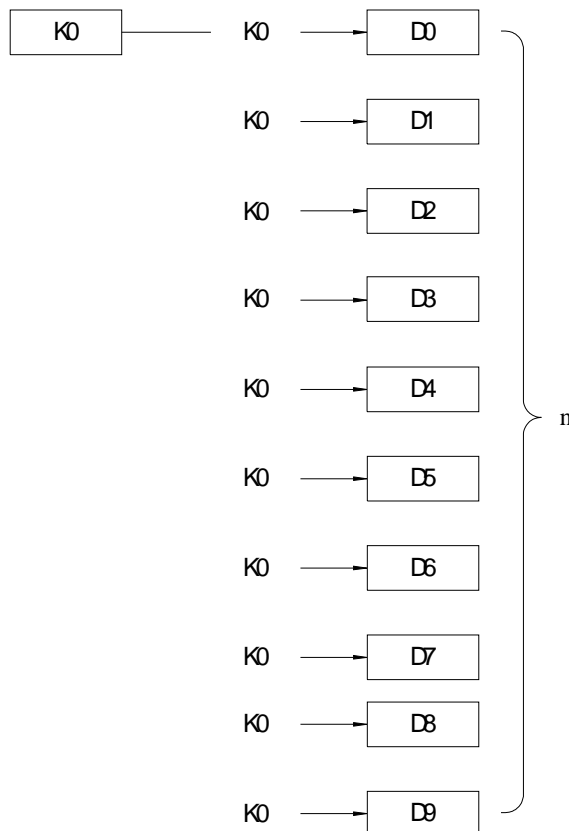

[FWRT]		Suitable Models: XC1、XC3、XC5
<u>16 bits instruction:</u> FWRT	<u>32 bits instruction:</u> DFWRT	

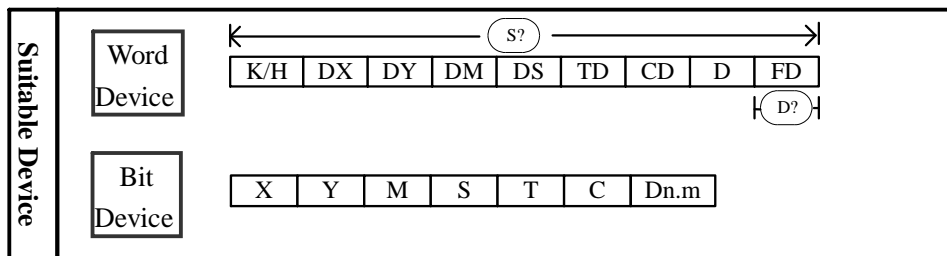

Function

1、Written of a word

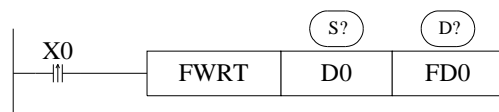

Function: write value in D0 into FD0

2、Written of double word

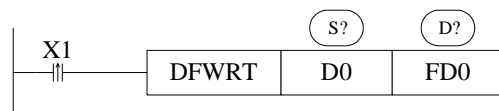

Function: write value in D0、D1 into FD0、FD1

3、Written of multi-word

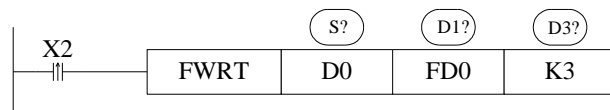

Function: write value in D0、D2、D3 into FD0、FD1、FD2.

- Note: 1, FWRT instruction only allow to write data into FlashROM register. In this storage area, even battery drop, data could be stored. So it could be used to store important technical parameters.
- 2, Written of FWRT needs a long time, about 150ms, so, frequently operate this operation is not recommended.
- 3, The written time of FlashROM is about 1,000,000 times. So, we suggest using edge signals (LDP、LDF etc.) to trigger.
- ※ Frequently written of FlashROM will ruin FlashROM forever.

[MSET]		Suitable Models: XC1、XC3、XC5
16 bits instruction: MSET	32 bits instruction: -	

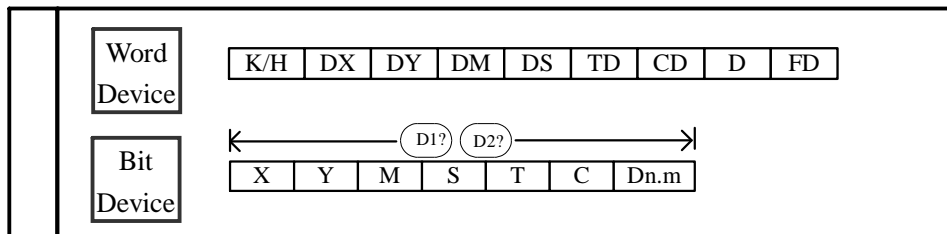

[ZRST]		Suitable Models: XC1、XC3、XC5
16 bits instruction: ZRST	32 bits instruction: -	

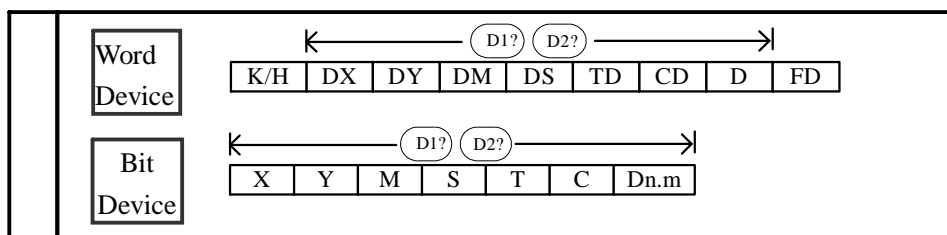

Function & Action

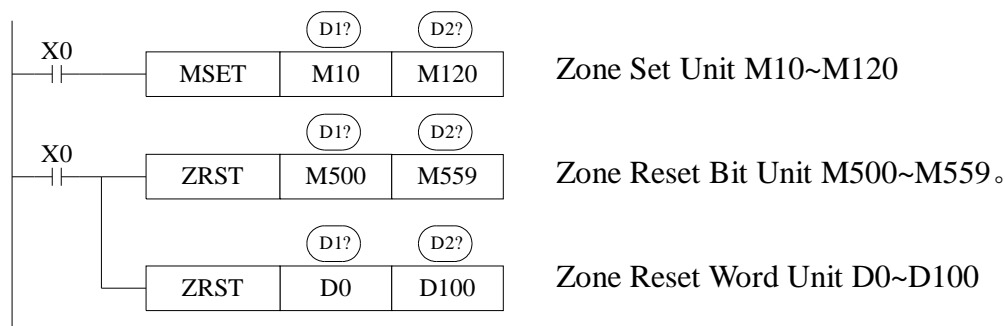

- (D1?) (D2?) Are specified as the same type of soft units, and (D1?) < (D2?)
When (D1?) > (D2?) , only reset the soft unit specified in (D1?)

Other Reset Instruction

- As soft unit's separate reset instruction, RST instruction can be used to bit unit Y, M, S and word unit T, C, D.
- As fill move for constant K0, 0 can be written into DX, DY, DM, DS, T, C, D.

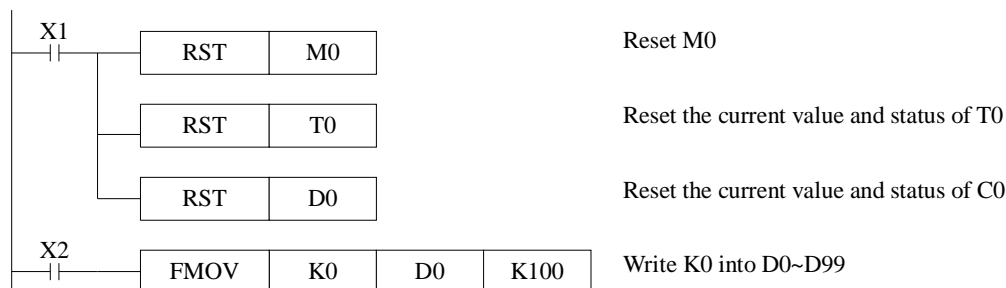

[SWAP]		Suitable Models: XC1、XC3、XC5
<u>16bits instruction:</u> SWAP	<u>32 bits instruction:</u> -	

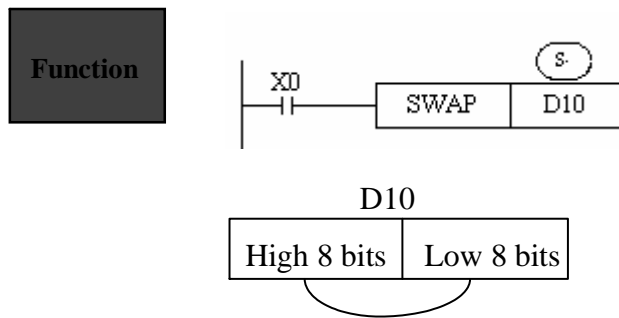
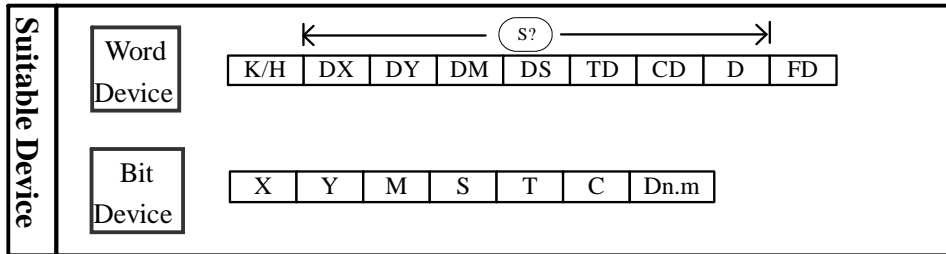

- Low 8 bits and high 8 bits change when it is 16 bits instruction.
- If the instruction is a consecutive executing instruction, each operation cycle should change.

[XCH]		Suitable Models: XC1、XC3、XC5
16 bits instruction: XCH	32 bits instruction: DXCH	

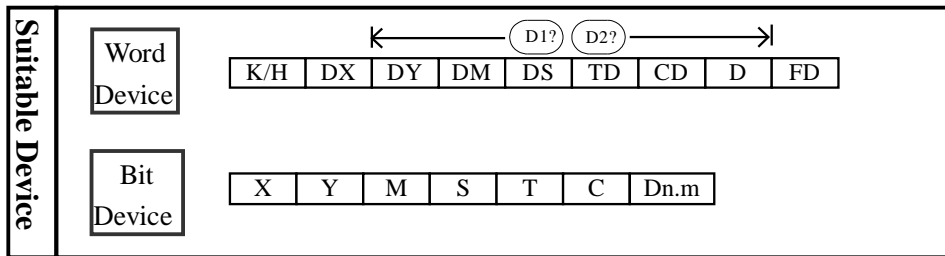

Function

《16 bits instruction》

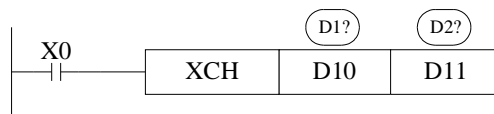

Before (D10) =100 →After (D10) =101
 (D11) =101 (D11) =100

- The contents of the two destination devices D1 and D2 are swapped,
- When drive input X0 is ON, each scan cycle should carry on data exchange.

《32 bits instruction》

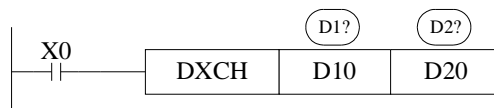

- 32 bits instruction [DXCH] swaps value composed by D10、D11 and the value composed by D20、D21

5-6. Data Operation Instructions

Mnemonic	Function
ADD	Addition
SUB	Subtraction
MUL	Multiplication
DIV	Division
INC	Increment
DEC	Decrement
MEAN	Mean
WAND	Logic Word And
WOR	Logic Word Or
WXOR	Logic Exclusive Or
CML	Compliment
NEG	Negation

Addition Operation [ADD]		Suitable Models: XC1、XC3、XC5
<u>16 bits instruction:</u> ADD	<u>32 bits instruction:</u> DADD	

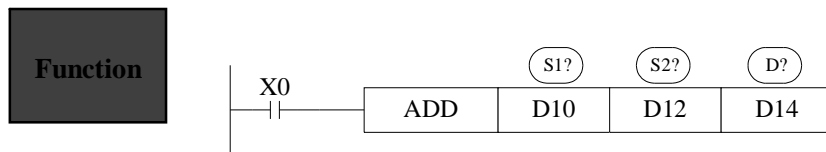
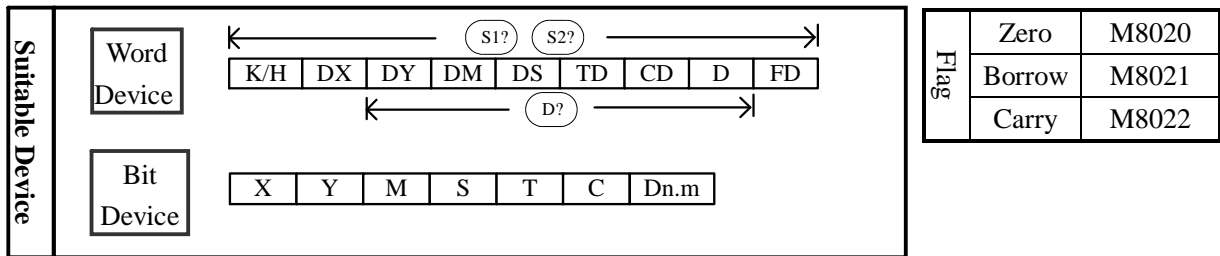

$$(D10) + (D12) \rightarrow (D14)$$

- The data contained within the two source devices are combined and the total is stored in the specified destination device. Each data's highest bit is the sign bit, 0 stands for positive、1 stands for negative. All calculations are algebraic processed. (5+ (-8) =-3)
- If the result of a calculation is "0", the "0" flag acts. If the result exceeds 323, 767 (16 bits limit) or 2,147,483,647 (32 bits limit) , the carry flag acts. (refer to the next page) . If the result exceeds -323,768 (16 bits limit) or -2,147,483,648 (32 bits limit) , the borrow flag acts (Refer to the next page)
- When carry on 32 bits operation, word device's low 16 bits are assigned, the device following closely the preceding device's ID will be the high bits. To avoid ID repetition, we recommend you assign device's ID to be even ID.
- The same device may be used as a source and a destination. If this is the case then the result changes after every scan cycle. Please note this point.

[SUB]		Suitable Models: XC1、XC3、XC5
16 bits instruction: SUB	32 bits instruction: DSUB	

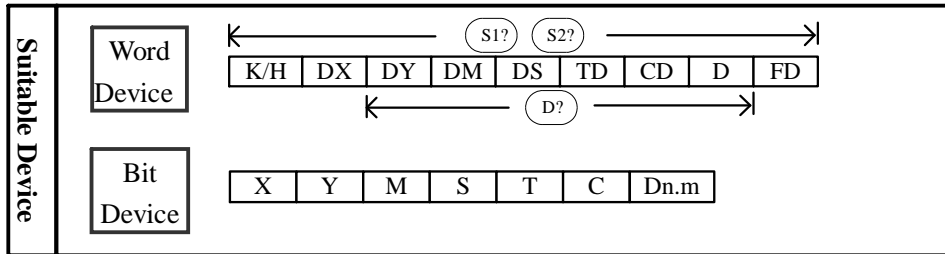

Flag	Zero	M8020
	Borrow	M8021
	Carry	M8022

Function

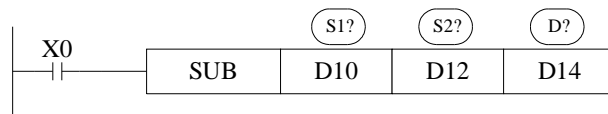

$$(D10) - (D12) \rightarrow (D14)$$

- $(S1?)$ appoint the soft unit's content, subtract the soft unit's content appointed by $(S2?)$ in the format of algebra. The result will be stored in the soft unit appointed by $(D?)$. $(5 - (-8) = 13)$
- The action of each flag, the appointment method of 32 bits operation's soft units are both the same with the preceding ADD instruction.
- The importance is: in the preceding program, if X0 is ON, SUB operation will be executed every scan cycle

The relationship of the flag's action and vale's positive/negative is shown below:

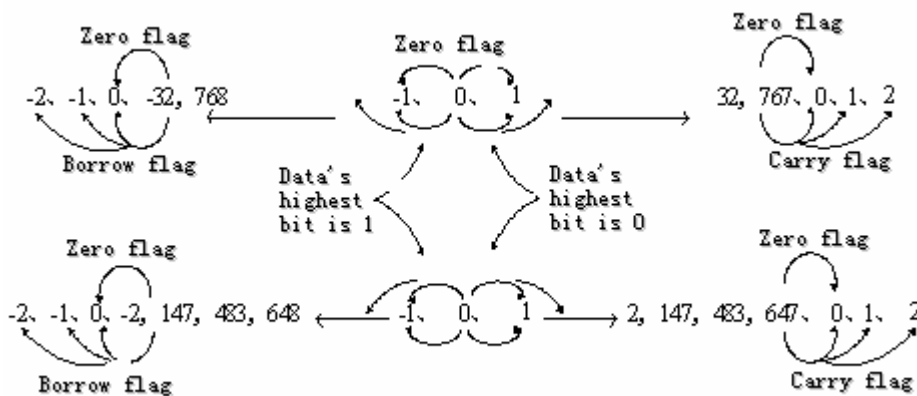

[MUL]		Suitable Models: XC1、XC3、XC5
16 bits instruction: MUL	32 bits instruction: DMUL	

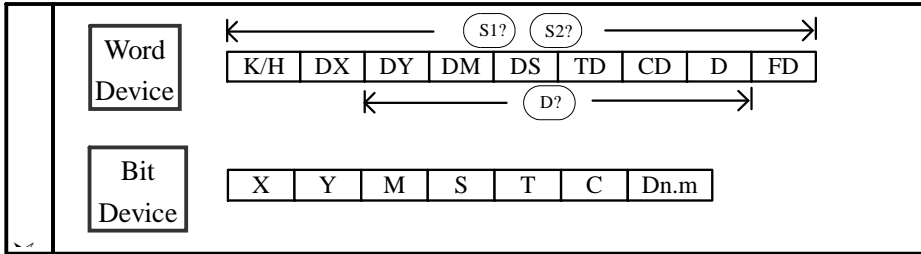

Flag	Zero	M8020
	Borrow	M8021
	Carry	M8022

Function & action

《16 bits operation》

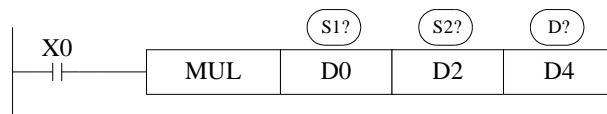

BIN BIN BIN
 (D0) ? (D2) → (D5, D4)
 16 bits 16 bits → 32 bits

- The contents of the two source devices are multiplied together and the result is stored at the destination device in the format of 32 bits. As in the upward chart: when (D0)=8、(D2)=9, (D5, D4) =72.
- The result's highest bit is the symbol bit: positive (0)、negative (1).
- When be bit unit, it can carry on the bit appointment of K1~K8. When appoint K4, only the result's low 16 bits can be obtained.

《32 bits operation》

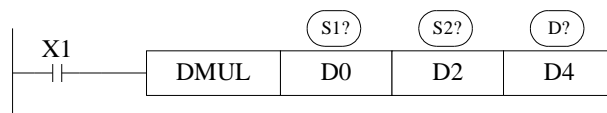

BIN BIN BIN
 (D1, D0) ? (D3, D2) → (D7, D6, D5, D4)
 32 bits 32 bits → 64 bits

- In 32 bits operation, when use bit device as the destination address, only low 32 bits result can be obtained. The high 32 bits result can not be obtained, so please operate again after transfer one time to the word device
- Even use word device, 64 bits results can't be monitored at once.
- In this situation, float point data operation is recommended.

[DIV]		特殊功能 Suitable Models:
16 bits instruction: DIV	32 bits instruction: DDIV	XC1、XC3、XC5

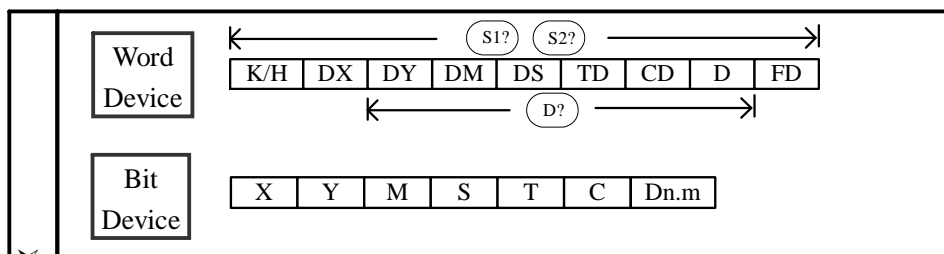

Flag	Zero	M8020
	Borrow	M8021
	Carry	M8022

Function & Action

《16 bits operation》

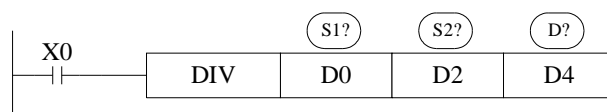

Dividend	Divisor	Result	Remainder
BIN	BIN	BIN	BIN
(D0) ?	(D2) →	D4) ---	(D5)
16 bits	16 bits	16 bits	16 bits

- (S1?) appoints the device's content be the dividend, (S2?) appoints the device's content be the divisor, (D?) appoints the device and the next one to store the result and the remainder.
- In the above example, if input X0 is ON, division operation is executed every scan cycle.

《32 bits operation》

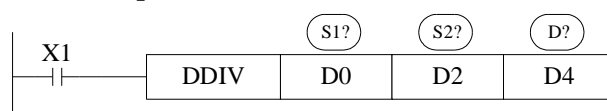

Dividend	Divisor	Result	Remainder
BIN	BIN	BIN	BIN
(D1,D0) ?	(D3,D2)	(D5,D4) ---	(D7,D6)
32 bits	32 bits	32 bits	32 bits

- The dividend is composed by the device appointed by (S1?) and the next one. The divisor is composed by the device appointed by (S2?) and the next one. The result and the remainder are stored in the four sequential devices, the first one is appointed by (D?)
- If the value of the divisor is 0, then an operation error is executed and the operation of the DIV instruction is cancelled.
- The highest bit of the result and remainder is the symbol bit (positive:0, negative: 1). When any of the dividend or the divisor is negative, then the result will be negative. When the dividend is negative, then the remainder will be negative.

[INC] & [DEC]		Suitable Models: XC1、XC3、XC5
16 bits instruction: INC、DEC	32 bits instruction: DINC、DDEC	

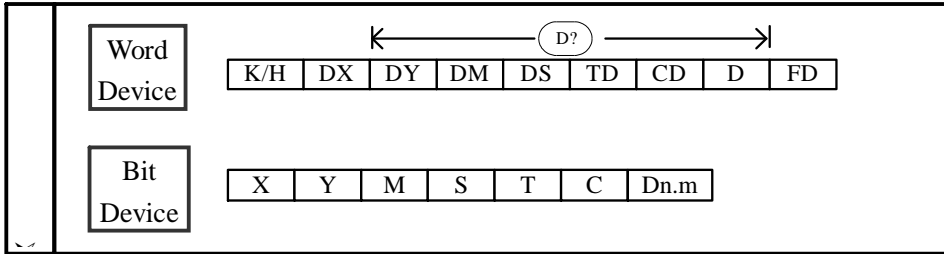

Flag	Zero	M8020
	Borrow	M8021
	Carry	M8022

Function & Action

1、Increment [INC]

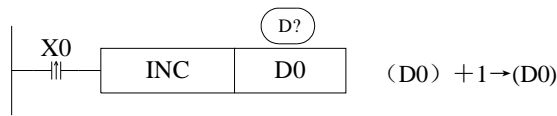

- On every execution of the instruction the device specified as the destination (D?) has its current value incremented (increased) by a value of 1.
- In 16 bits operation, when +32, 767 is reached, the next increment will write -32, 767 to the destination device. In this case, there's no additional flag to identify this change in the counted value.

2、Decrement [DEC]

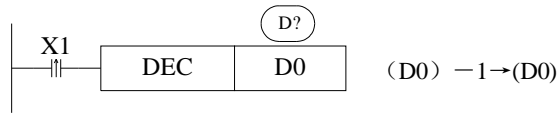

- On every execution of the instruction the device specified as the destination (D?) has its current value decremented (decreased) by a value of 1.
- When -32, 768 or -2, 147, 483, 648 is reached, the next decrement will write +32, 767 or +2, 147, 483, 647 to the destination device.

[MEAN]		Suitable Models: XC1、XC3、XC5
<u>16 bits instruction:</u> MEAN	<u>32 bits instruction:</u> -	

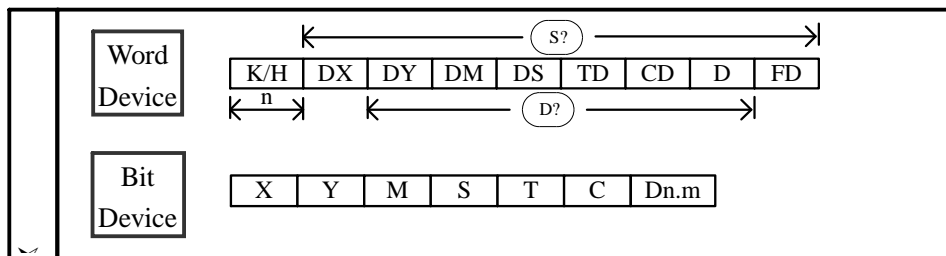

Flags	Zero	M8020
	Borrow	M8021
	Carry	M8022

Function & Action

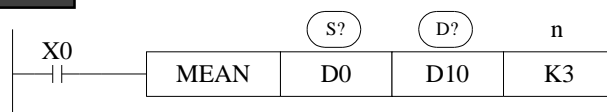

$$\frac{(D0) + (D1) + (D2)}{3} \longrightarrow (D10)$$

- The value of all the devices within the source range is summed and then divided by the number of devices summed, i.e. n.. This generates an integer mean value which is stored in the destination device (D) The remainder of the calculated mean is ignored.
- If the value of n is specified outside the stated range (1 to 64) an error is generated.

[WAND], [WOR] & [WXOR]		Suitable Models: XC1, XC3, XC5
<u>16 bits instruction:</u> WAND, WOR	<u>32 bits instruction:</u> DWAND, DWOR	

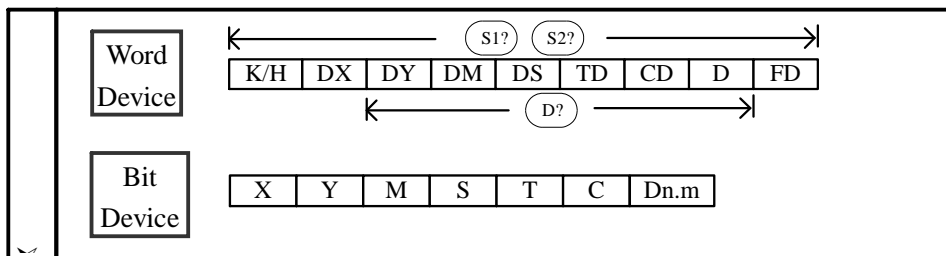

Flags	Zero	M8020
	Borrow	M8021
	Carry	M8022

Function & Action

- Execute logic AND operation with each bit



- Execute logic OR operation with each bit

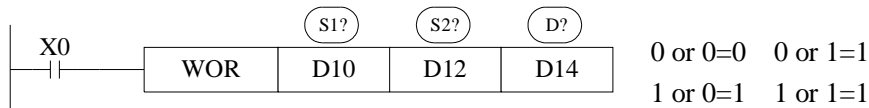

- Execute logic Exclusive OR operation with each bit.

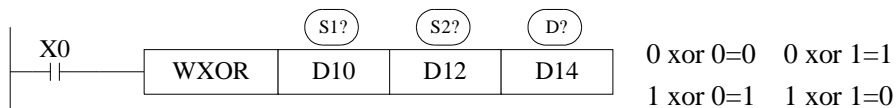

If use this instruction along with CML instruction, XOR NOT operation could also be executed.

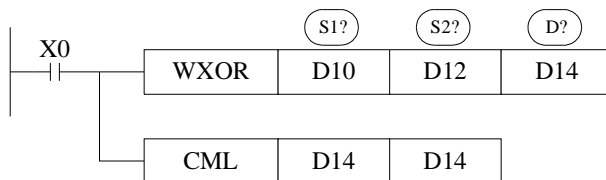

[CML]		Suitable Models: XC1、XC3、XC5
16 bits instruction: CML	32 bits instruction: DCML	

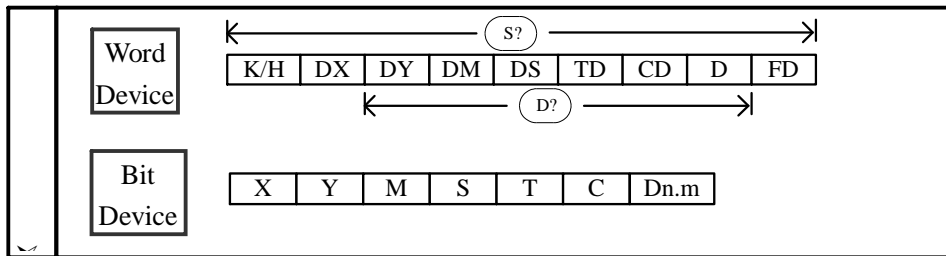

Function & Action

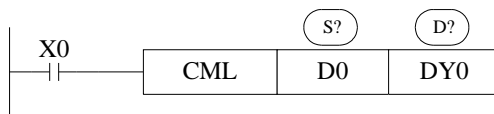

A copy of each data bit within the source device is inverted and then moved to the designated destination.

- Each data bit in the source device is inverted (0->1, 1->0) and sent to the destination device. If use constant K in the source device, it can be auto convert to be binary.
- It's available when you want to inverted output the PLC's output

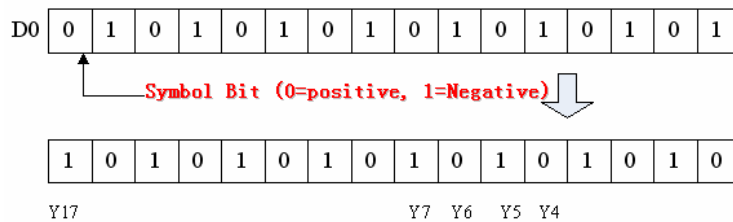

《Reading of inverted input》

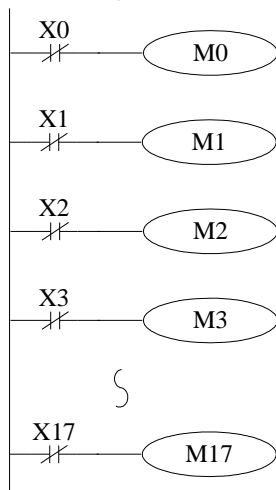

The sequential control instruction in the left could be denoted by the following CML instruction.



[NEG]		Suitable Models: XC1、XC3、XC5
<u>16 bits instruction:</u> NEG	<u>32 bits instruction:</u> DNEG	

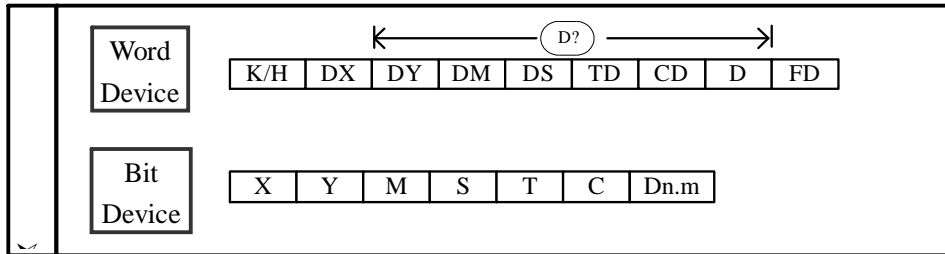

Function & Action

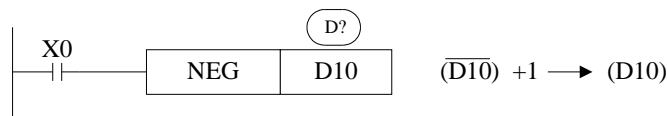

- The bit format of the selected device is inverted, I.e. any occurrence of a “1” becomes a “0” and any occurrence of “0” becomes “1”, when this is complete, a further binary 1 is added to the bit format. The result is the total logic sign change of the selected devices contents.

5-7. Shift Instructions

Mnemonic	➤ Function
SHL	Arithmetic shift left
SHR	Arithmetic shift right
LSL	Logic shift left
LSR	Logic shift right
ROL	Rotation left
ROR	Rotation right
SFTL	Bit shift left
SFTR	Bit shift right
WSFL	Word shift left
WSFR	Word shift right

[SHL] & [SHR]		Suitable Models:
<u>16 bits instruction:</u> SHL、SHR	<u>32 bits instruction:</u> DSHL、DSHR	XC3、XC5

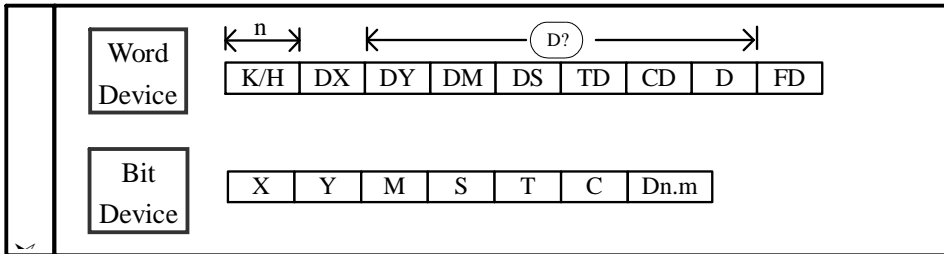

Function & Action

《Arithmetic shift left》

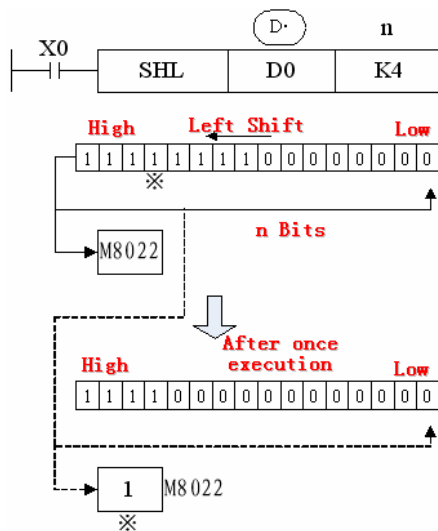

- After once execution, the low bit is filled in 0, the final bit is stored in carry flag.

《Arithmetic shift right》

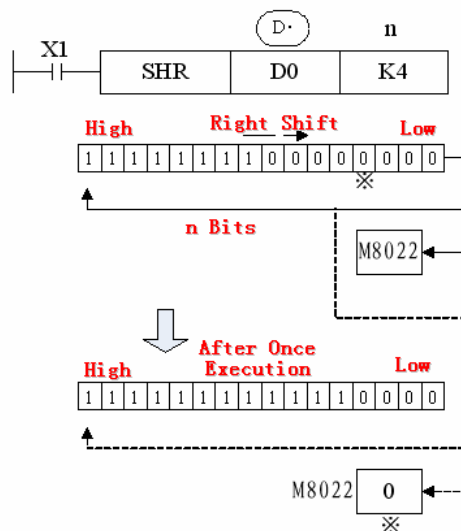

- After once execution, the high bit is same with the bit before shifting, the final bit is stored in carry flag.

Note:

- In the left example, when X1 is ON, left/right shift is executed at every scan cycle.

[LSL] & LSR		Suitable Models:
16 bits instruction:	32 bits instruction: DLSL、DLSR	XC3、XC5

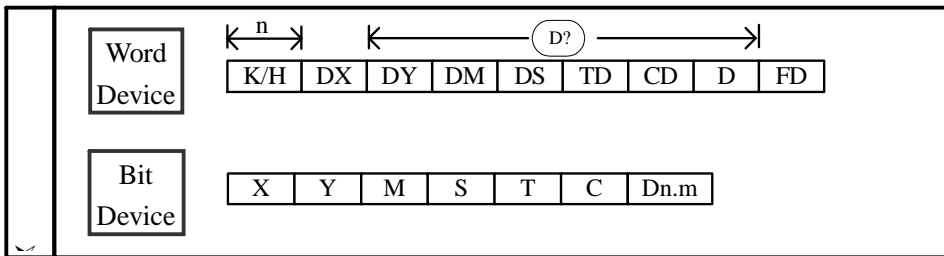

Function & Action

《Logic shift left》

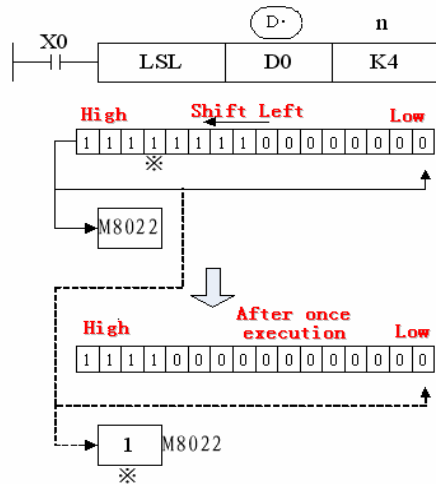

- After once execution, the low bit is filled in 0, the final bit is stored in carry flag.

《Logic shift right》

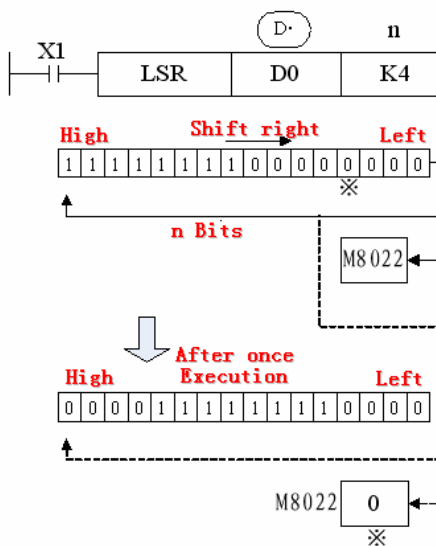

- After once execution, the high bit is same with the bit before shifting, the final bit is stored in carry flag.

NOTE:

- In every scan cycle, loop shift left/right action will be executed

[ROL] & [ROR]		Suitable Models: XC3、XC5
16 bits instruction: ROL、ROR	32 bits instruction: DROL、DROR	

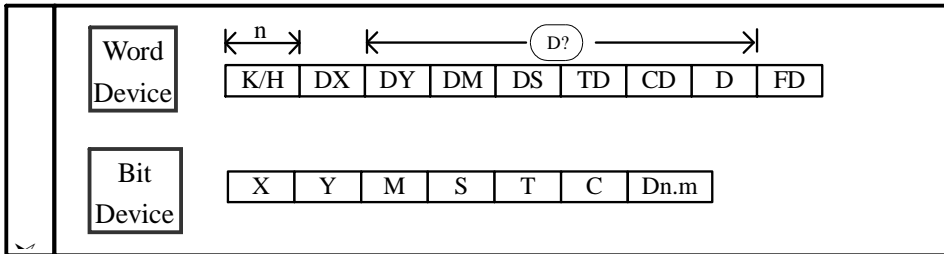

Function & Action

The bit format of the destination device is rotated n bit places to the left on every operation of the instruction

《Rotation shift left》

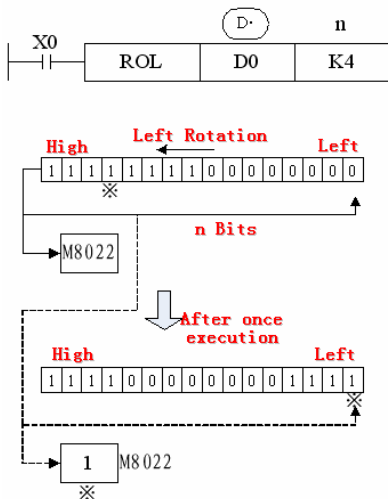

- Every time when X000 turns from OFF to ON, executes n bits left rotation.

《Rotation shift right》

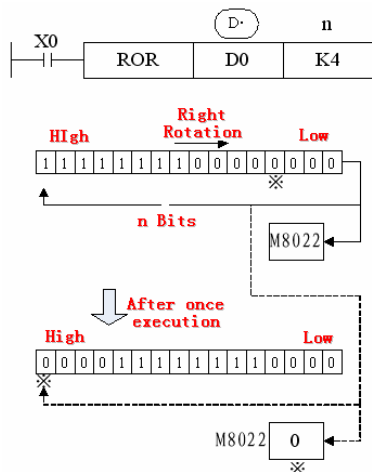

- Every time when X000 turns from OFF to ON, executes n bits right rotation.

[SFTL] & [SFTR]		Suitable Models: XC3、XC5
16 bits instruction: SFTL、SFTR	32 bits instruction: DSFTL、DSFTR	

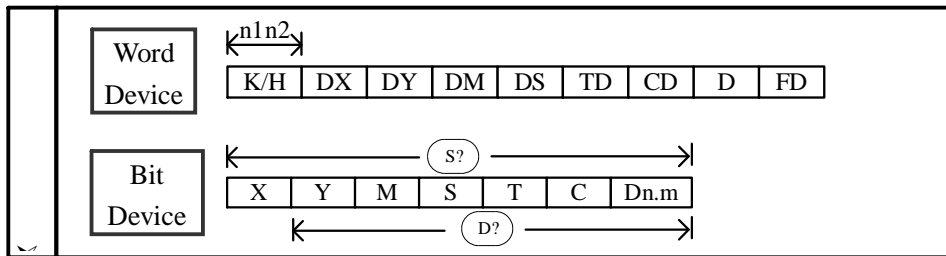

Function & Action

- The instruction copies n2 source devices to a bit stack of length n1. For every new addition of n2 bits, the existing data within the bit stack is shifted n2 bits to the left/right. Any bit data moving to the position exceeding the n1 limit is diverted to an overflow area. The bit shifting operation will occur every time the instruction is processed unless it is modified with either the pulse suffix or a controlled interlock.

《Bit shift left》

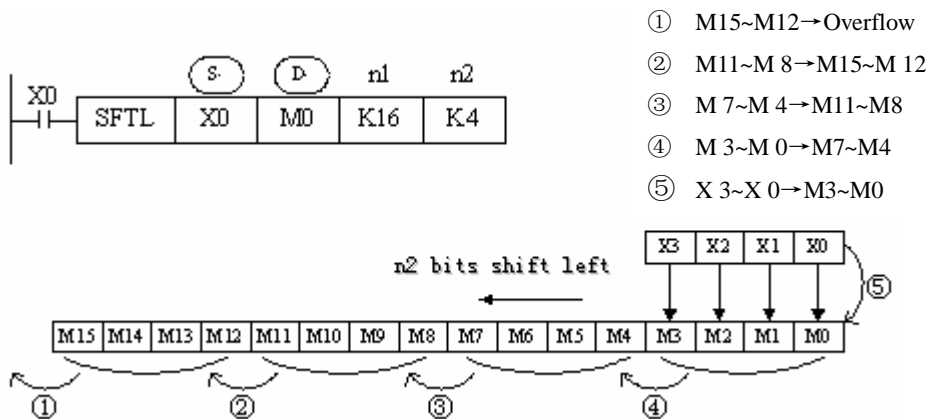

《Bit shift right》

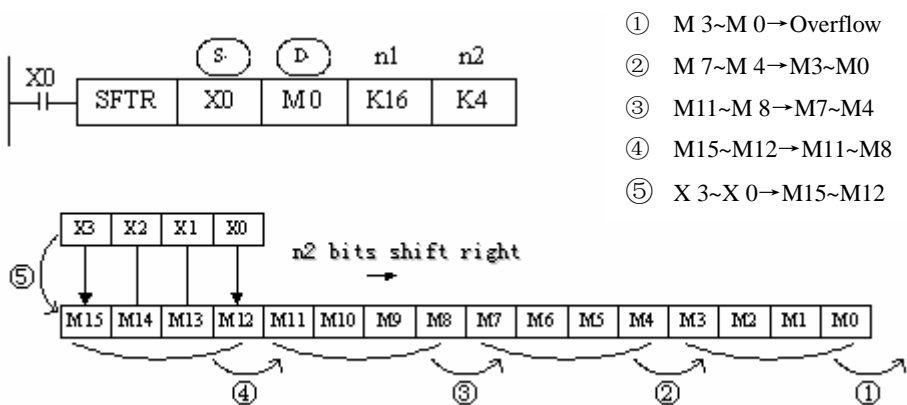

- In every scan cycle, loop shift left/right action will be executed

[WSFL] & [WSFR]		Suitable Models: XC3、XC5
<u>16 bits instruction:</u> WSFL、WSFR	<u>32 bits instruction:</u> DWSFL、DWSFR	

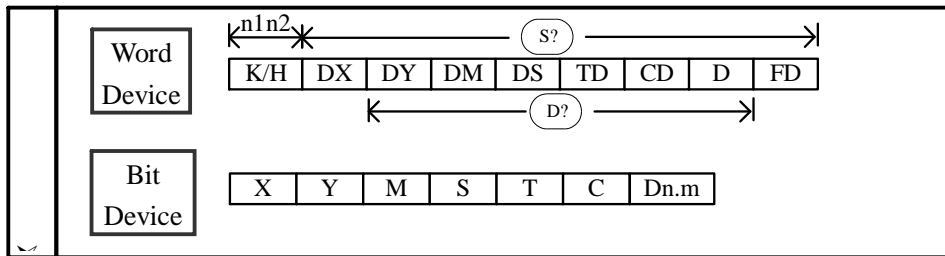

Function & Action

- The instruction copies n2 source devices to a word stack of length n1. For each addition of n2 words, the existing data within the word stack is shifted n2 words to the left/right. Any word data moving to a position exceeding the n1 limit is diverted to an overflow area. The word shifting operation will occur every time the instruction is processed unless it is modified with either the pulse suffix or a controller interlock.

《Word shift left》

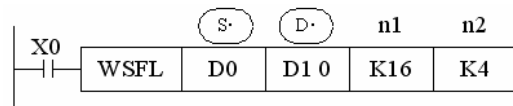

- ① D25~D22→ overflow
- ② D21~D18→D25~D22
- ③ D17~D14→D21~D18
- ④ D13~D10→D17~D14
- ⑤ D3~D0→D13~D10

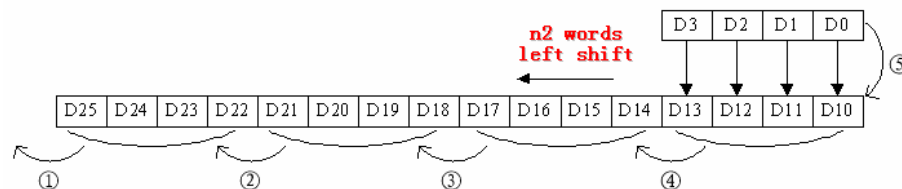

《Word shift right》

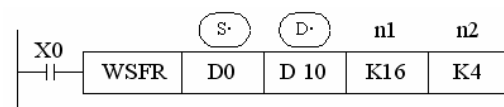

- ① D13~D10→ overflow
- ② D17~D14→D13~D10
- ③ D21~D18→D17~D14
- ④ D25~D22→D21~D18
- ⑤ D3~D0→D25~D22

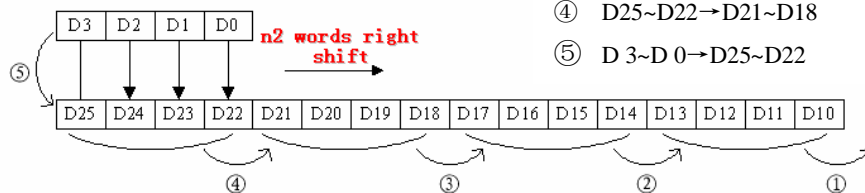

- In every scan cycle, loop shift left/right action will be executed

5-8. Data Convert

Mnemonic	Function
WTD	Single word integer converts to double word integer
FLT	32 bits integer converts to float point
FLTD	64 bits integer converts to float point
INT	Float point converts to integer
BIN	BCD convert to binary
BCD	Binary converts to BCD
ASC	Hex. converts to ASCII
HEX	ASCII converts to Hex.
DECO	Coding
ENCO	High bit coding
ENCOL	Low bit coding

[WTD]		Suitable Models: XC3、XC5
<u>16 bits instruction:</u> WTD	<u>32 bits instruction:</u> -	

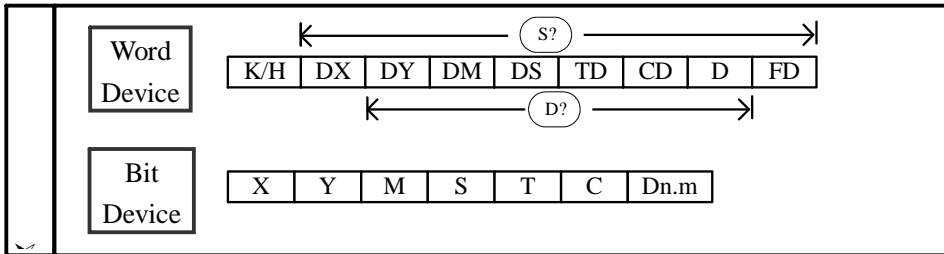

Function & Action

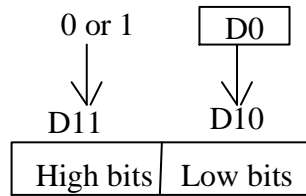
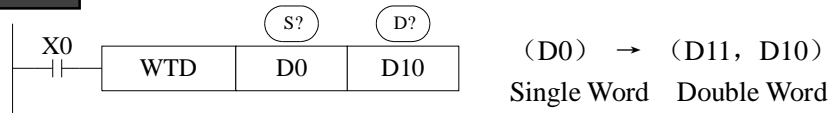

- When single word D0 is positive integer, after executing this instruction, the high bit of double word D10 is 0.
- When single word D0 is negative integer, after executing this instruction, the high bit of double word D10 is 1.

[FLT] & [FLTD]		Suitable Models: XC3、XC5
16 bits instruction: FLT	32 bits instruction: DFLT	

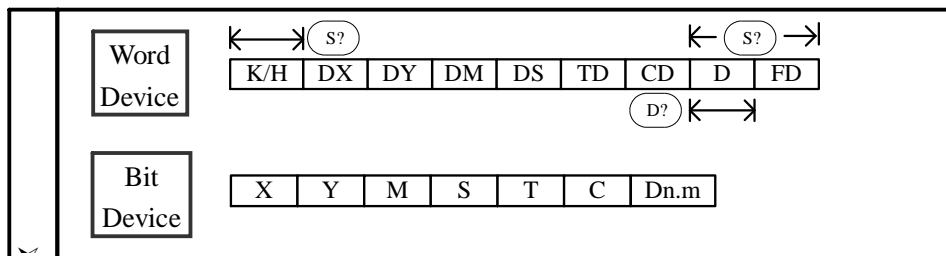

Function & Action

《16 Bits》

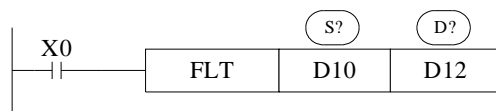

(D10) → (D13,D12)
BIN integer Binary float point

《32 Bits》

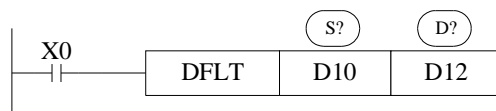

(D11,D10) → (D13,D12)
BIN integer Binary float point

《64 Bits》

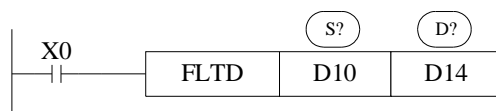

(D13,D12,D11,D10) → (D17,D16,D15,D14)
BIN integer Binary float point

- Convert BIN integer to binary float point. As the constant K、H will auto convert by the float operation instruction, so this FLT instruction can't be used.
- The instruction is contrary to INT instruction.

[INT]		Suitable Models: XC3、XC5
<u>16 bits instruction:</u> -	<u>32 bits instruction:</u> INT	

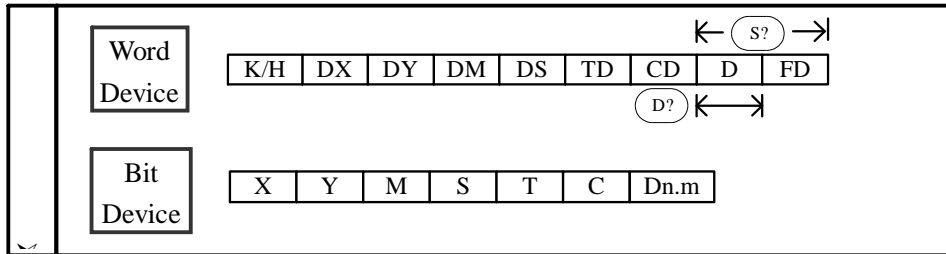

Function & Action

《16 位》

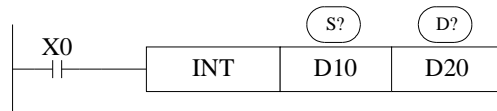

(D11,D10) → (D20)
 Binary Floating BIN integer
 Give up the data after the decimal dot

《32 位》

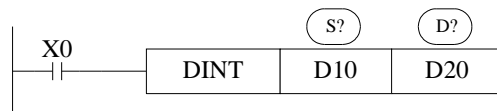

(D11,D10) → (D20,D21)
 Binary Floating BIN integer
 Give up the data after the decimal dot

- The binary source number is converted into an BIN integer and stored at the destination device. Abandon the value behind the decimal point.
- This instruction is contrary to FLT instruction.
- When the result is 0, the flag bit is ON.
 When converting, less than 1 and abandon it, zero flag is ON.
 16 bits operation: -32,768~32,767
 32 bits operation: -2,147,483,648~2,147,483,647

[BIN]		Suitable Models: XC3、XC5
<u>16 bits instruction:</u> BIN	<u>32 bits instruction:</u> -	

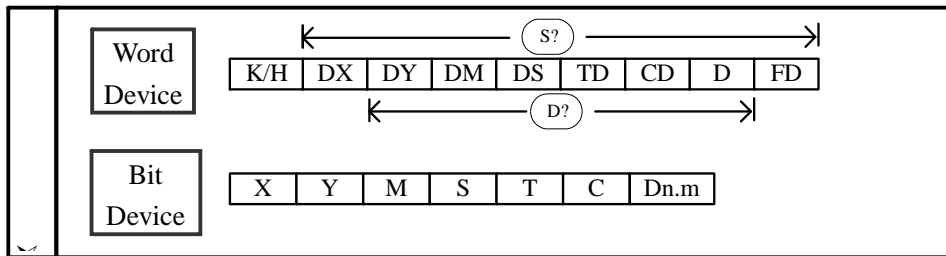

Function & Action

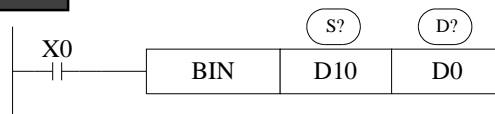

Convert and move instruction of Source (BCD) → destination (BIN)

- When source data is not BCD code, M8067 (Operation error), M8068 (Operation error lock) will not work.
- As constant K automatically converts to binary, so it's not suitable for this instruction.

[BCD]		Suitable Models: XC3、XC5
<u>16 bits instruction:</u> BCD	<u>32 bits instruction:</u> -	

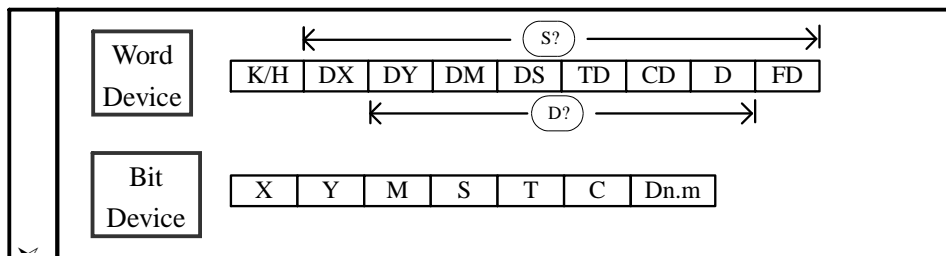

Function & Action

Convert and move instruction of source (BIN)→destination (BCD).

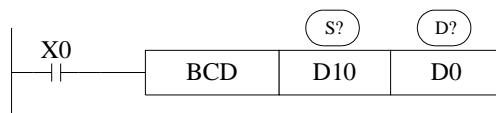

- This instruction can be used to output data directly to a seven-segment display.

[ASCII]		Suitable Models: XC3、XC5
<u>16 bits instruction:</u> ASCII	<u>32 bits instruction:</u> -	

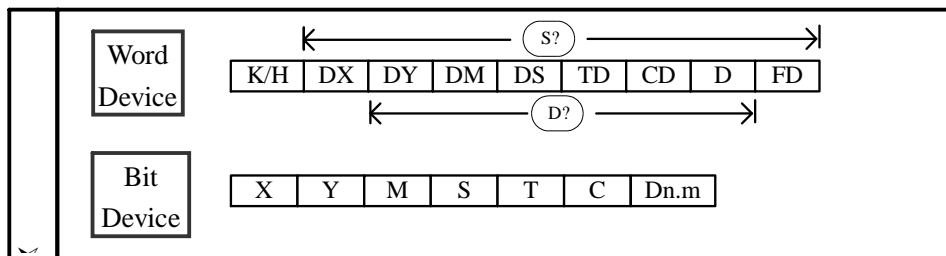

Function & Action

《16 bits convert mode》

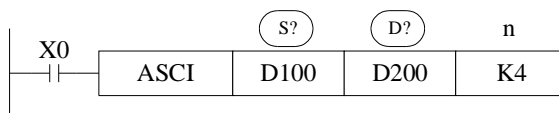

Convert each bit of source's (S) Hex. format data to be ASCII code, move separately to the high 8 bits and low 8 bits of destination (D). The convert alphanumeric number is assigned with n. (D) is low 8 bits, high 8 bits, store ASCII data.

The convert result is the

Assign start device:	[0]=30H	[1]=31H	[5]=35H
(D100)=0ABCH	[A]=41H	[2]=32H	[6]=36H
(D101)=1234H	[B]=42H	[3]=33H	[7]=37H
(D102)=5678H	[C]=43H	[4]=34H	[8]=38H

D \ n	K1	K2	K3	K4	K5	K6	K7	K8	K9
D200 down	[C]	[B]	[A]	[0]	[4]	[3]	[2]	[1]	[8]
D200 up		[C]	[B]	[A]	[0]	[4]	[3]	[2]	[1]
D201 down			[C]	[B]	[A]	[0]	[4]	[3]	[2]
D201 up				[C]	[B]	[A]	[0]	[4]	[3]
D202 down					[C]	[B]	[A]	[0]	[4]
D202 up						[C]	[B]	[A]	[0]
D203 down							[C]	[B]	[A]
D203 up								[C]	[B]
D204 down									[C]

[HEX]		Suitable Models: XC3、XC5
16 bits instruction: HEX	32 bits instruction: -	

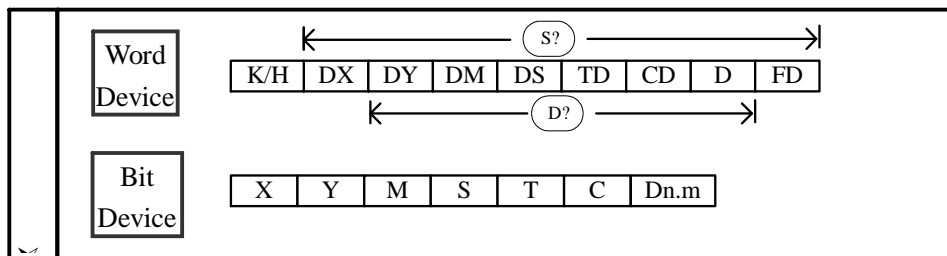

Function & Action

《16 bits switch mode》

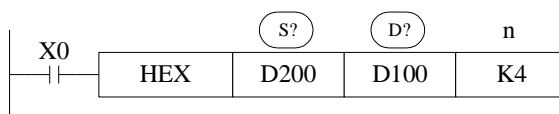

Convert the high and low 8 bits in source to HEX data. Move 4 bits every time to destination. The convert alphanumeric number is assigned by n.

The convert of the upward program is the following:

(S?)	ASCII Code	HEX Convert
D200 down	30H	0
D200 up	41H	A
D201 down	42H	B
D201 up	43H	C
D202 down	31H	1
D202 up	32H	2
D203 down	33H	3
D203 up	34H	4
D204 down	35H	5

(D?)	D102	D101	D100
n			
1	Not change to be 0		? 0H
2			? 0AH
3			? 0ABH
4			0ABCH
5		? 0H	ABC1H
6		? 0AH	BC12H
7		? 0ABH	C123H
8		0ABCH	1234H
9	? 0H	ABC1H	2345H

n=k4

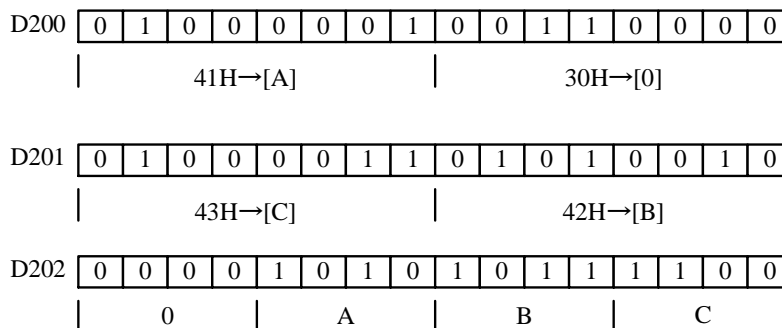

[DECO]		Suitable Models: XC3、XC5
16 bits instruction: DECO	32 bits instruction: -	

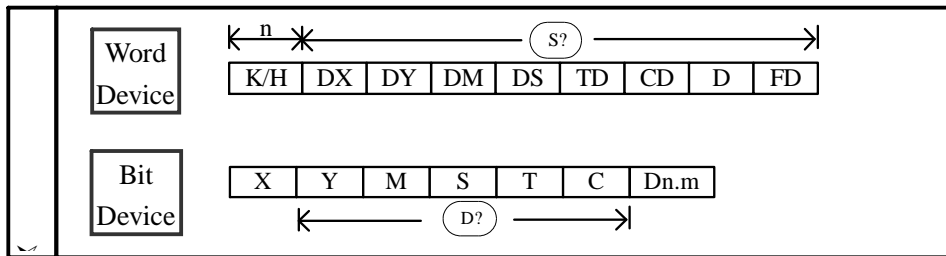

Function & Action

《 When (D?) is software unit》 $n \leq 16$

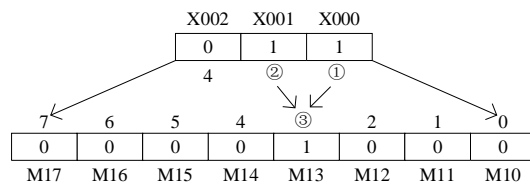
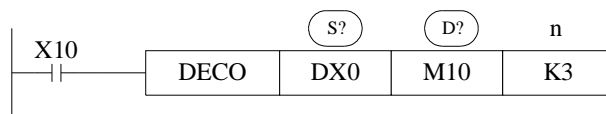

- The source address is $1+2=3$, so starts from M10, the number 3 bit (M13) is 1. If the source are all 0, M10 is 1
- When $n=0$, no operation, beyond $n=0\sim 16$, don't execute the instruction.
- When $n=16$, if coding command "D" is soft unit, it's point is $2^8=256$.
- When drive input is OFF, instructions are not executed, the activate coding output keep on activate.

《 When (D?) is word device》 $n \leq 4$

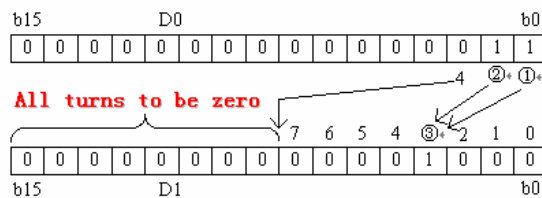
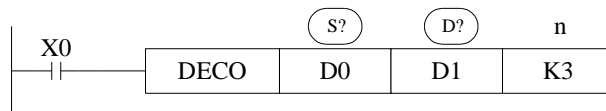

- Source ID's low n bits ($n \leq 4$) are encoded to the destination ID. When $n \leq 3$, destination's high bits all converts to be 0.
- When $n=0$, no disposal, beyond $n=0\sim 4$, don't execute the instruction.

[ENCO]		Suitable Models: XC3、XC5
16 bits instruction: ENCO	32 bits instruction: -	
Word Device		
Bit Device		

Function & Action

《 When (S?) is bit device》 $n \leq 16$

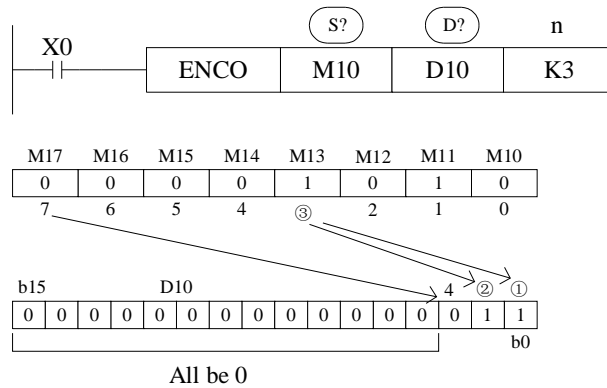

《 When (S?) is word device》 $n \leq 4$

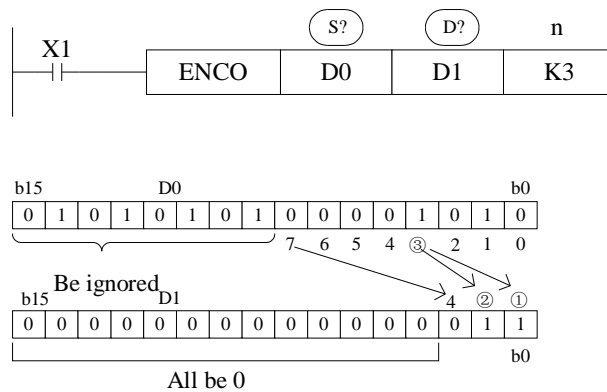

- If many bits in the source ID are 1, ignore the low bits. If source ID are all 0, don't execute the instructions.
- When drive input is OFF, the instruction is not executed, encode output don't change.
- When $n=8$, if encode instruction's "S" is bit unit, it's point number is $2^8=256$

[ENCOL]		Suitable Models: XC3、XC5
<u>16 bits instruction:</u> ENCOL	<u>32 bits instruction:</u> -	

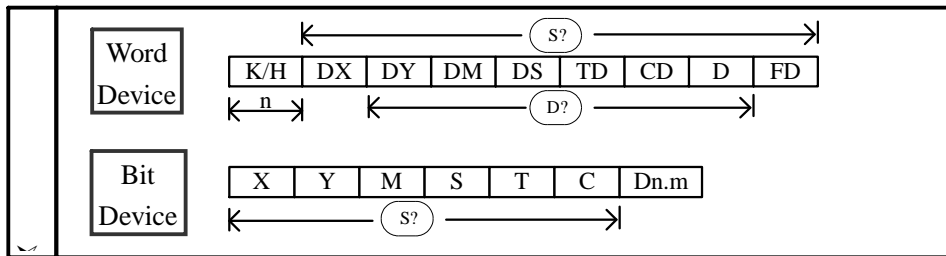

Function & Action

《 If (S?) is bit device》 $n \leq 16$

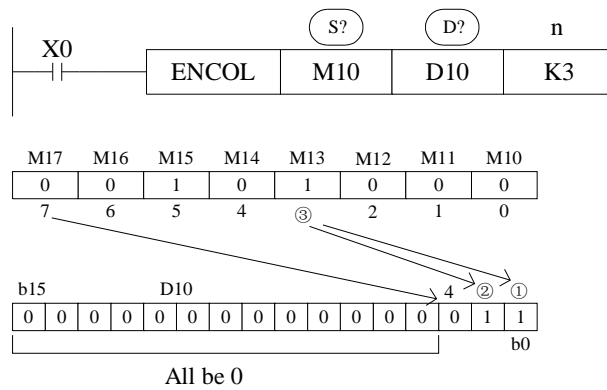

《 (S?) 是字软元件时》 $n \leq 16$

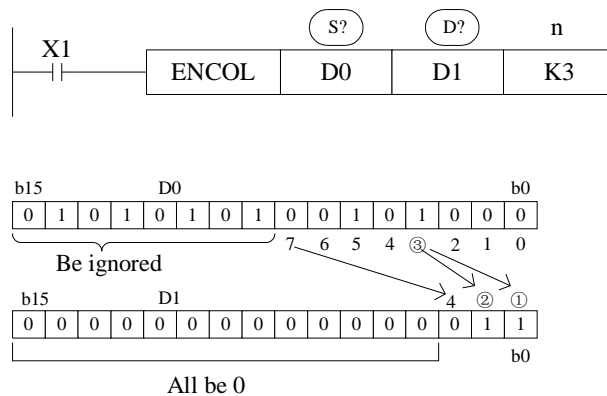

- If many bits in the source ID are 1, ignore the high bits. If source ID are all 0, don't execute the instructions.
- When drive input is OFF, the instruction is not executed, encode output don't change.
- When $n=8$, if encode instruction's "S" is bit unit, it's point number is $2^8=256$

5-9. Floating Operation

Mnemonic	Function
ECMP	Float Compare
EZCP	Float Zone Compare
EADD	Float Add
ESUB	Float Subtract
EMUL	Float Multiplication
EDIV	Float Division
ESQR	Float Square Root
SIN	Sine
COS	Cosine
TAN	Tangent

[ECMP]		Suitable Models: XC3、XC5
<u>16 bits instruction:</u> -	<u>32 bits instruction:</u> ECMP	

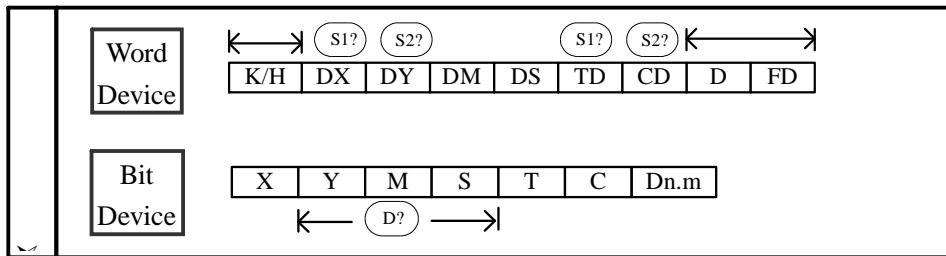

Function & Action

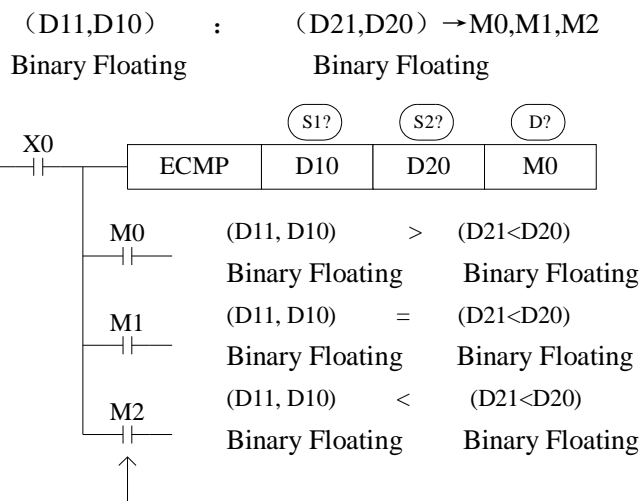

The status of the destination device will be kept even if the ECMP instruction is deactivated.

- The binary float data of S1 is compared to S2. The result is indicated by 3 bit devices specified with the head address entered as D.
- If a constant K or H used as source data, the value is converted to floating point before the addition operation.

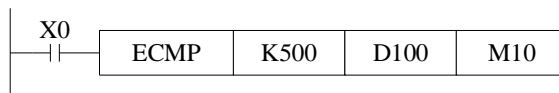

(K500) : (D101, D100) → M10,M11,M12
 Binary converts Binary floating
 to floating

[EZCP]		Suitable Models: XC3、XC5
<u>16 bits instruction:</u> -	<u>32 bits instruction:</u> ECMP	

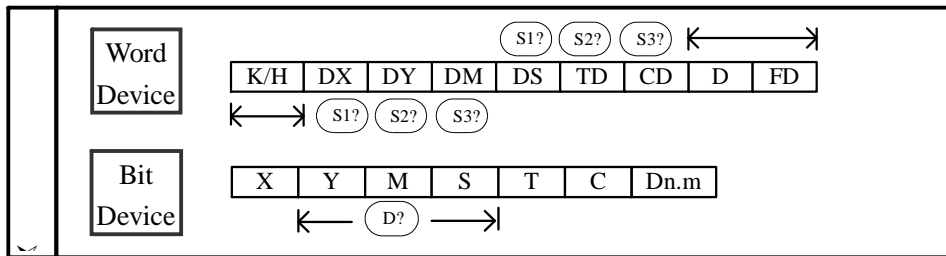

Function & Action

Compare a float range with a float value.

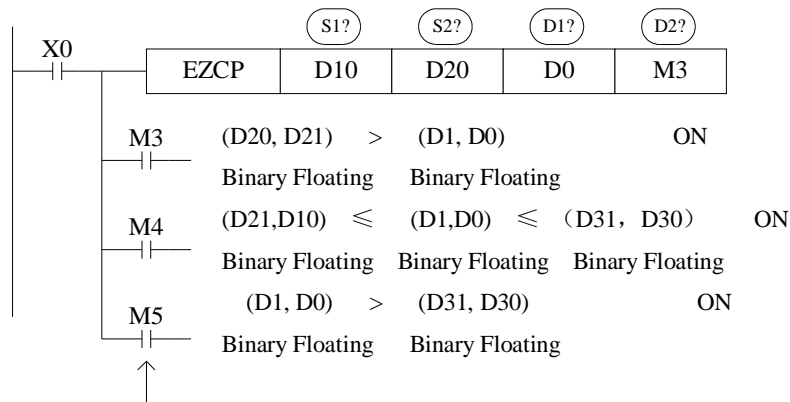

The status of the destination device will be kept even if the EZCP instruction is deactivated.

- The data of S1 is compared to the data of S2. The result is indicated by 3 bit devices specified with the head address entered as D.
- If a constant K or H used as source data, the value is converted to floating point before the addition operation.

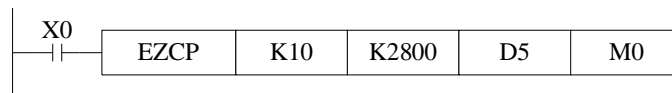

(K10) : [D6,D5] : (K2800) → M0, M1, M2
 Binary converts to Floating Binary Floating Binary converts to Floating

Please set S1<S2, when S2>S1, see S2 as the same with S1 and compare them.

[EADD]		Suitable Models: XC3、XC5
<u>16 bits instruction:</u> -	<u>32 bits instruction:</u> EADD	

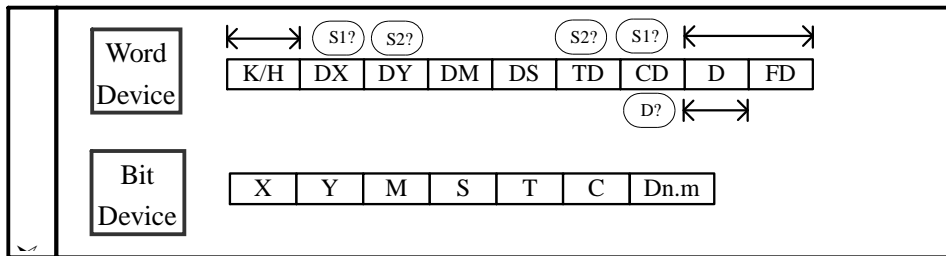

Function & Action

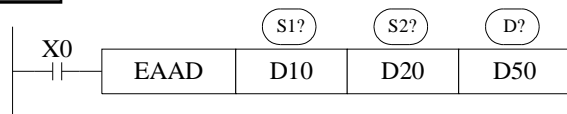

(D11,D10) + (D21,D20) → (D51,D50)
Binary Floating Binary Floating Binary Floating

- The floating point values stored in the source devices S1 and S2 are algebraically added and the result stored in the destination device D.
- If a constant K or H used as source data, the value is converted to floating point before the addition operation.

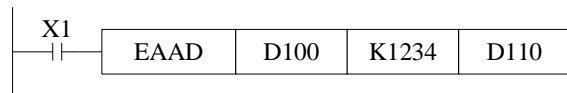

(K1234) + (D101,D100) → (D111,D110)
Binary converts to Floating Binary Floating Binary Floating

- The same device may be used as a source and as the destination. If this is the case then, on continuous operation of the EADD instruction, the result of the previous operation will be used as a new source value and a new result calculated. This will happen every program scan unless the pulse modifier or an interlock program is used.

[ESUB]		Suitable Models: XC3、XC5
<u>16 bits instruction:</u> -	<u>32 bits instruction:</u> ESUB	

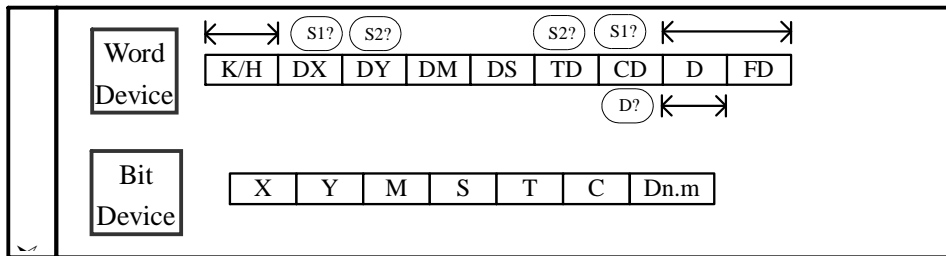

Function & Action

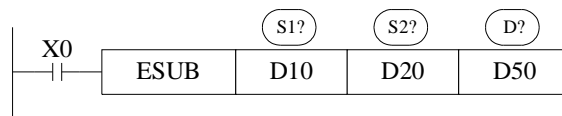

$$(D11,D10) \text{ Binary Floating} - (D21,D20) \text{ Binary Floating} \rightarrow (D51,D50) \text{ Binary Floating}$$

- The floating point value of S2 is subtracted from the floating point value of S1 and the result stored in destination device D.
- If a constant K or H used as source data, the value is converted to floating point before the addition operation.

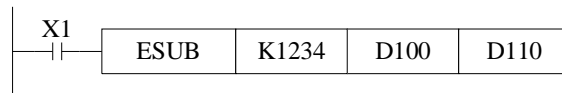

$$(K1234) \text{ Binary converts to Floating} - (D101,D100) \text{ Binary Floating} \rightarrow (D111,D110) \text{ Binary Floating}$$

- The same device may be used as a source and as the destination. If this is the case then, on continuous operation of the EADD instruction, the result of the previous operation will be used as a new source value and a new result calculated. This will happen every program scan unless the pulse modifier or an interlock program is used.

[EMUL]		Suitable Models: XC3、XC5
16 bits instruction: -	32 bits instruction: EMUL	

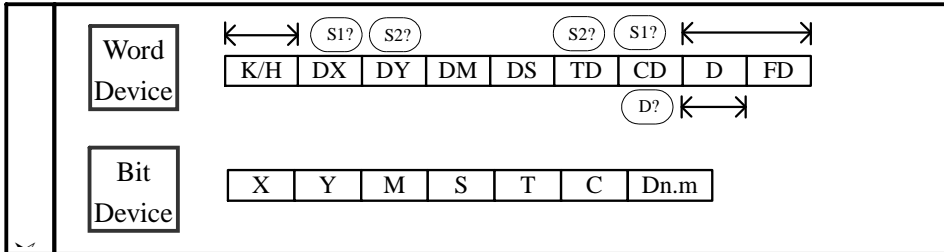

Function & Action

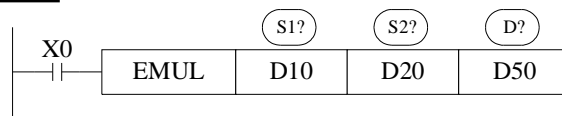

(D11, D10) ? (D21,D20) → (D51,D50)
 Binary Floating Binary Floating Binary Floating

- The floating value of S1 is multiplied with the floating value point value of S2. The result of the multiplication is stored at D as a floating value.
- If a constant K or H used as source data, the value is converted to floating point before the addition operation.

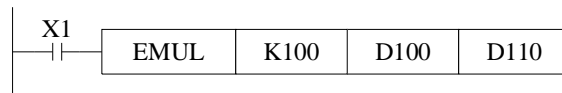

(K100) ? (D101,D100) → (D111,D110)
 Binary converts to Floating Binary Floating Binary Floating

[EDIV]		Suitable Models: XC3、XC5
16 bits instruction: -	32 bits instruction: EDDIV	

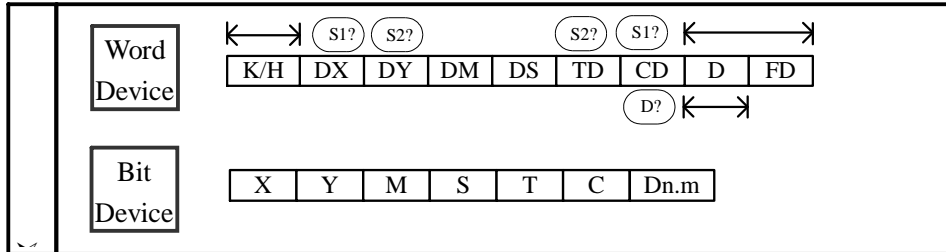

Function & Action

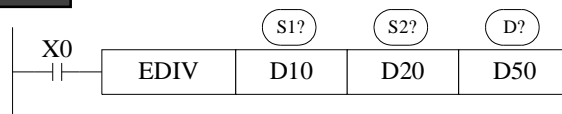

(D11,D10) ? (D21,D20) → (D51,D50)

Binary Floating Binary Floating Binary Floating

- The floating point value of S1 is divided by the floating point value of S2. The result of the division is stored in D as a floating point value. No remainder is calculated.
- If a constant K or H used as source data, the value is converted to floating point before the addition operation.

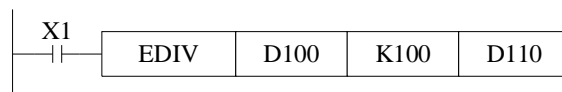

(D101,D100) ? (K100) → (D111,D110)

Binary Floating Binary converts to Floating Binary Floating

- If S2 is zero then a divide by zero error occurs and the operation fails.

[ESQR]		Suitable Models: XC3、XC5
<u>16 bits instruction:</u> -	<u>32 bits instruction:</u> ESQR	

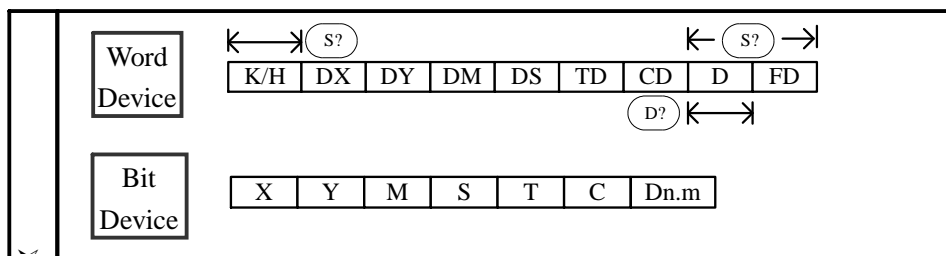

Function & Action

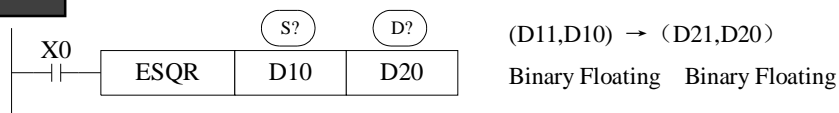

- A square root is performed on the floating point value in S the result is stored in D.
- If a constant K or H used as source data, the value is converted to floating point before the addition operation.

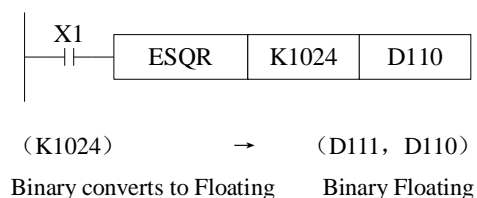

- When the result is zero, zero flag activates
- Only when the source data is positive will the operation be effective. If S is negative then an error occurs and error flag M8067 is set ON, the instruction can't be executed.

[SIN]		Suitable Models: XC3、XC5
<u>16 bits instruction:</u> -	<u>32 bits instruction:</u> SIN	

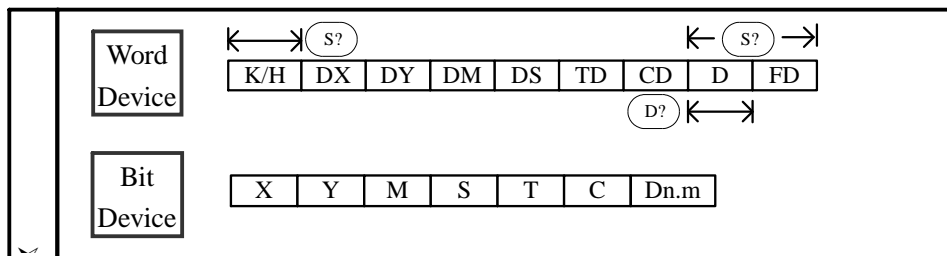

Function & Action

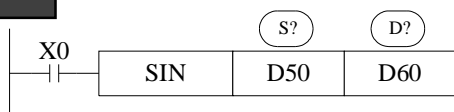

(D51,D50) → (D61,D60)SIN
 Binary Floating Binary Floating

- This instruction performs the mathematical SIN operation on the floating point value in S (angle RAD). The result is stored in D.

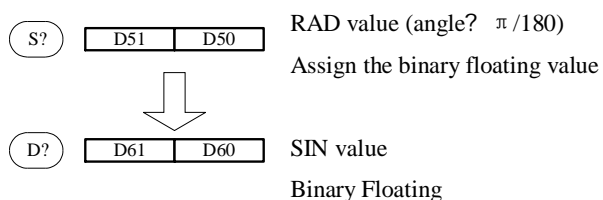

[COS]		Suitable Models: XC3、XC5
<u>16 bits instruction:</u> -	<u>32 bits instruction:</u> COS	

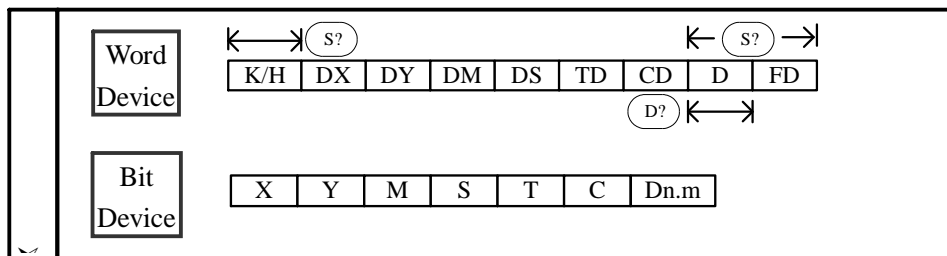

Function & Action

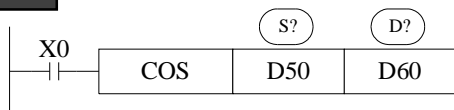

(D51,D50)RAD → (D61,D60)COS
 Binary Floating Binary Floating

- This instruction performs the mathematical COS operation on the floating point value in S (angle RAD). The result is stored in D.

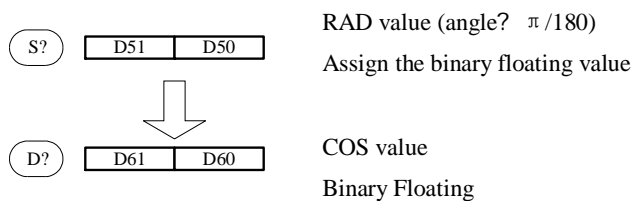

[TAN]		Suitable Models: XC3、XC5
<u>16 bits instruction:</u> -	<u>32 bits instruction:</u> TAN	

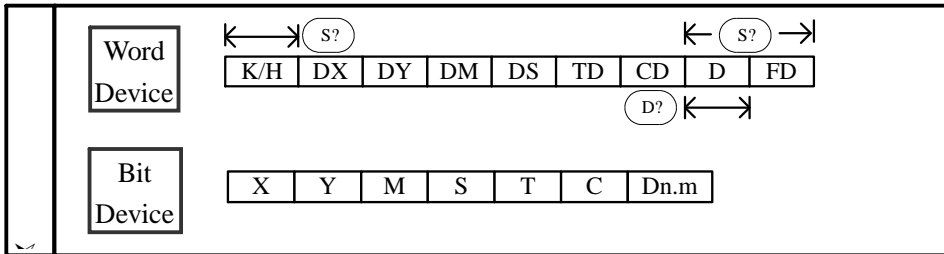

Function & Action

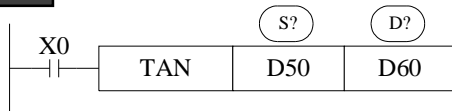

(D51,D50)RAD → (D61,D60)TAN
 Binary Floating Binary Floating

- This instruction performs the mathematical TAN operation on the floating point value in S. The result is stored in D.

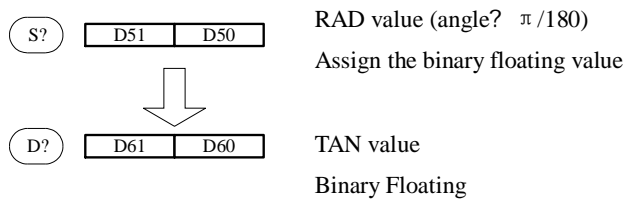

5-10. Clock Operation

Mnemonic	Function
TCMP	Time Compare
TZCP	Time Zone Compare
TADD	Time Add
TSUB	Time Subtract
TRD	Read RTC data
TWR	Set RTC data

Note: The models without clock can not use these instructions.

Time Compare [TCMP]		Suitable Models: XC3、XC5
16 bits instruction: DIV	32 bits instruction: DDIV	

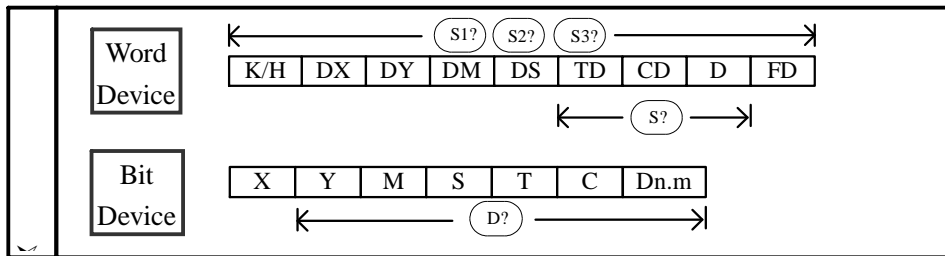

Function & Action

Compare the assigned time with time data.

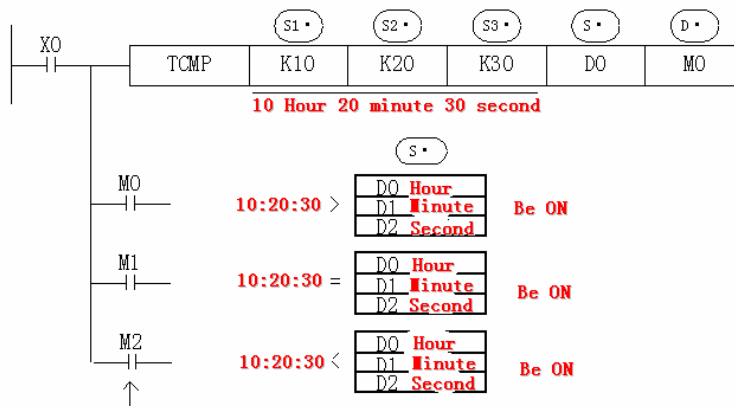

The status of the destination devices is kept, even if the TCMP instruction is deactivated.

- 「 (S1?) , (S2?) , (S3?) 」 represent hours, minutes and seconds respectively. This time is compared to the time value in the 3 data devices specified by the head address (S?), The result is indicated in the 3 bit devices specified by the head address (D?)

- (S1?): Assign the compare standard “Hour”
- (S2?): Assign the compare standard “Minute”
- (S3?): Assign the compare standard “Second”

- (S?) : Assign the “Hour” of clock data
- (S?) + 1 : Assign the “Minute” of clock data
- (S?) + 2 : Assign the “Second” of clock data

(D?), (D?) + 1, (D?) + 2 : According to the compare result, the 3 devices output ON/OFF.

The valid range of “Hour” is 「0~23」 .
 The valid range of “Minute” is 「0~59」 .
 The valid range of “Second” is 「0~59」 .

[TZCP]		Suitable Models: XC3、XC5
16 bits instruction: DIV	32 bits instruction: DDIV	

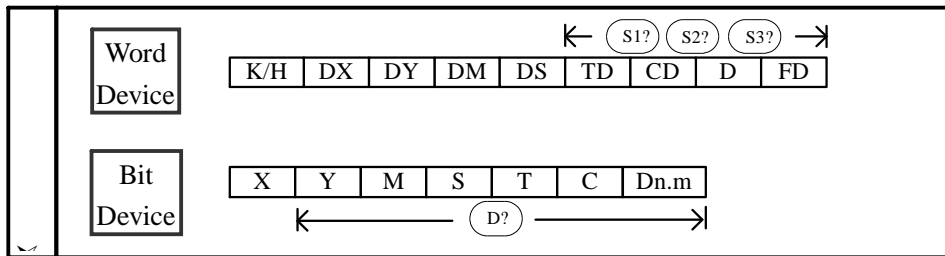

Function & Action

Compare the two assigned time with time data

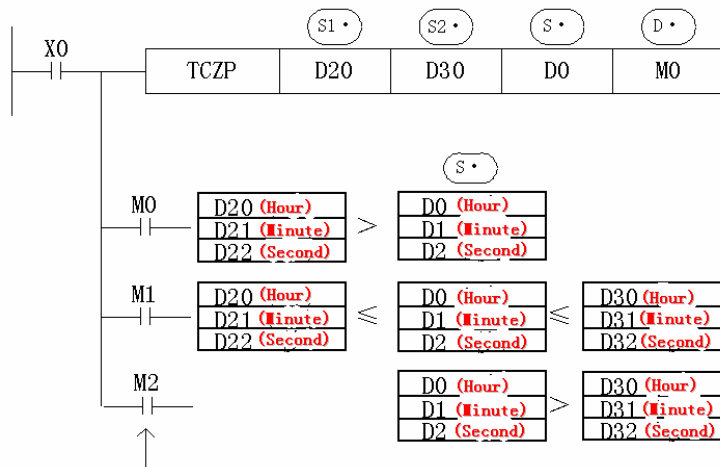

The status of the destination devices is kept, even if the TCMP instruction is deactivated.

- Compare the 3 clock data start from (S?) with the two ends on the clock compare bound, according to the area bound, output the three ON/OFF status starts from (D?)

- (S1?), (S1?) + 1, (S1?) + 2 : Assign the compare low limit in the form of “Hour”, “Minute” and “Second”.
- (S2?), (S2?) + 1, (S2?) + 2 : Assign the compare low limit in the form of “Hour”, “Minute” and “Second”.
- (S?), (S?) + 1, (S?) + 2 : Assign the clock data in the form of “Hour”, “Minute” and “Second”.
- (D?), (D?) + 1, (D?) + 2 : According to the compare result, the 3 devices output ON/OFF.

The valid range of “Hour” is 「0~23」 .
 The valid range of “Minute” is 「0~59」 .
 The valid range of “Second” is 「0~59」 .

[TADD]		Suitable Models: XC3、XC5
<u>16 bits instruction:</u> DIV	<u>32 bits instruction:</u> DDIV	

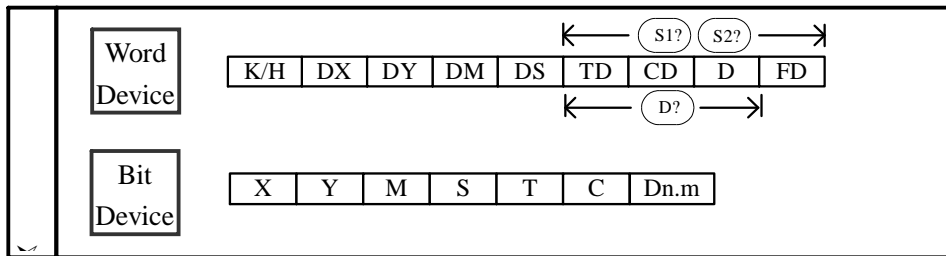

Function & Action

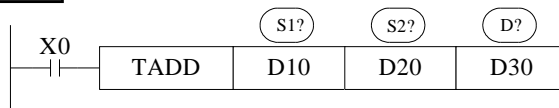

$$(D10, D11, D12) + (D20, D21, D22) \rightarrow (D30, D31, D32)$$

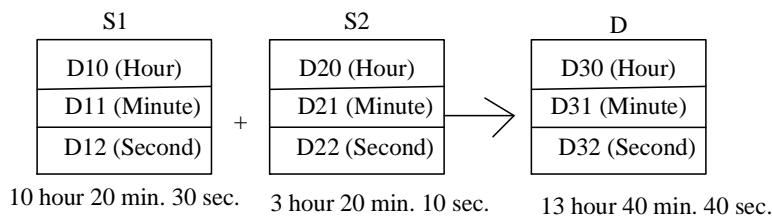

- Each of S1, S2 and D specify the head address of 3 data devices to be used a time value. The time value in S1 is added to the value in S2, the result is stored to D as a new time value.
- If the addition of the two times results in a value greater than 24 hours, the value of the result is the time remaining above 24 hours. When this happens the carry flag M8022 is

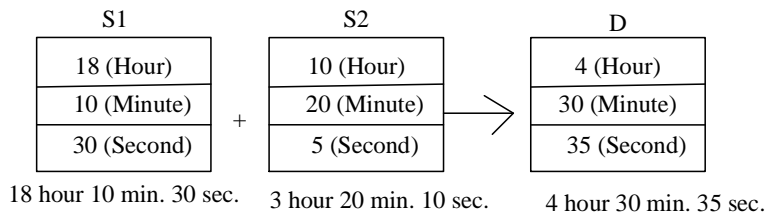

- When the result is 0 (0 Hour 0 Minute 0 Second), Set zero flag ON.

The valid range of “Hour” is 「0~23」 .
 The valid range of “Minute” is 「0~59」 .
 The valid range of “Second” is 「0~59」 .

[TSUB]		Suitable Models: XC3、XC5
16 bits instruction: DIV	32 bits instruction: DDIV	

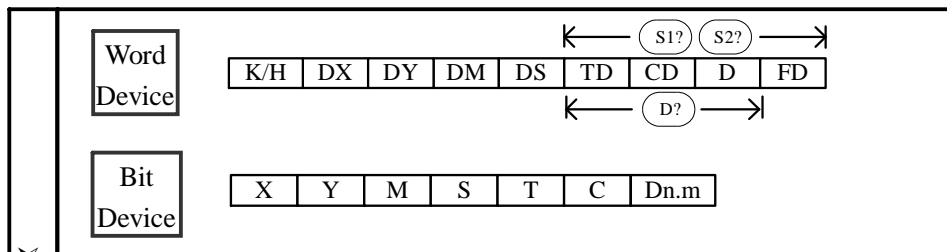

Function & Action

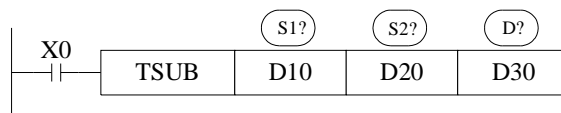

(D10, D11, D12) – (D20, D21, D22) → (D30, D31, D32)

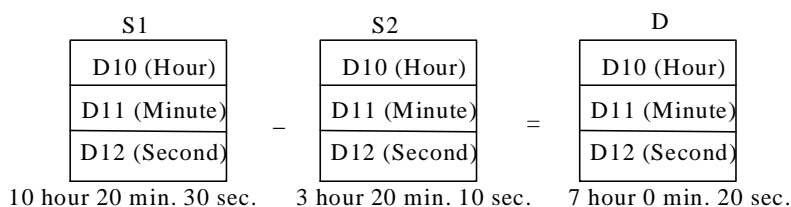

- Each of S1, S2 and D specify the head address of 3 data devices to be used a time value. The time value in S1 is subtracted from the time value in S2, the result is stored to D as a new time.
- If the subtraction of the two times results in a value less than 00:00:00 hours, the value of the result is the time remaining below 00:00:00 hours. When this happens the borrow flag M8021 is set ON.

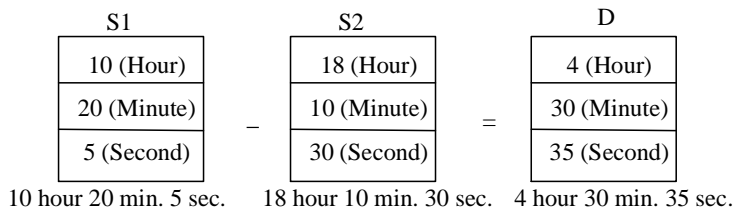

- When the result is 0 (0 hour 0 min. 0 sec.), zero flag set ON.

The valid range of “Hour” is 「0~23」 .
 The valid range of “Minute” is 「0~59」 .
 The valid range of “Second” is 「0~59」 .

[TRD]		Suitable Models: XC3、XC5
16 bits instruction: DIV	32 bits instruction: DDIV	

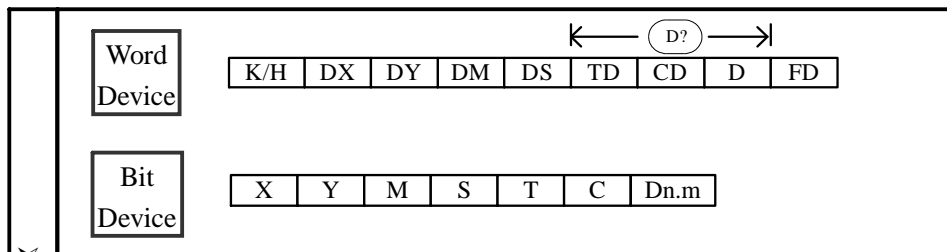

Function & Action

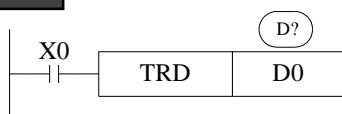

The current time and date of the real time clock are read and stored in the 7 data devices specified by the head address D.

- Read PLC's real time clock according to the following format.
The reading source is the special data register (D8013~D8019) which save clock data.

		Unit	Item	Clock data		Unit	Item
Special data register for real time clock	D8018	Year		0-99	→	D0	Year
	D8017	Month		1-12	→	D1	Month
	D8016	Date		1-31	→	D2	Date
	D8015	Hour		0-23	→	D3	Hour
	D8014	Minute		0-59	→	D4	Minute
	D8013	Second		0-59	→	D5	Second
	D8019	Week		0 (Sun.)-6 (Sat.)	→	D	Week

[TWR]		Suitable Models: XC3、XC5
16 bits instruction: DIV	32 bits instruction: DDIV	

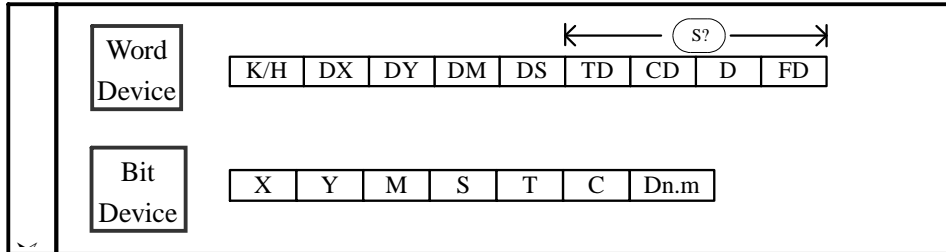

Function & Action

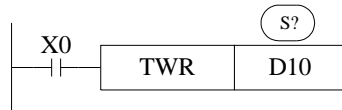

The 7 data devices specified with the

- Write the set clock data into PLC's real time clock.
In order to write real time clock, the 7 data devices with the head address (S?) should be pre-set.

	Unit	Item	Clock data		Unit	Item	
Data for clock setting	D0	Year	0-99	→	D8018	Year	Special data register for real time clock t
	D1	Month	1-12	→	D8017	Month	
	D2	Date	1-31	→	D8016	Date	
	D3	Hour	0-23	→	D8015	Hour	
	D4	Minute	0-59	→	D8014	Minute	
	D5	Second	0-59	→	D8013	Second	
	D6	Week	0 (Sun.)-6 (Sat.)	→	D8019	Week	

After executing TWR instruction, the time in real time clock will immediately change to be the new set time. So, when setting the time it is a good idea to set the source data to a time a number of minutes ahead and then drive the instruction when the real time reaches this value.

5. Applied Instructions

In this chapter, we describe applied instruction's function of XC series PLC.

5-1. Table of Applied Instructions

5-2. Reading Method of Applied Instructions

5-3. Flow Instructions

5-4. Contactors Compare Instructions

5-5. Move and Compare Instructions

5-6. Arithmetic and Logic Operation Instructions

5-7. Loop and Shift Instructions

5-8. Data Convert

5-9. Floating Operation

5-10. Clock Operation

5-1. Applied Instruction List

The applied instructions' sort and their correspond instructions are listed in the following table:

Common statements of XC1/XC3/XC5:

Sort	Mnemonic	Function
Program Flow	CJ	Condition jump
	CALL	Call subroutine
	SRET	Subroutine return
	STL	Flow start
	STLE	Flow end
	SET	Open the assigned flow, close the current flow
	ST	Open the assigned flow, not close the current flow
	FOR	Start of a FOR-NEXT loop
	NEXT	End of a FOR-NEXT loop
	FEND	First end
Data Compare	LD=	LD activates if (S1) = (S2)
	LD>	LD activates if (S1) > (S2)
	LD<	LD activates if (S1) < (S2)
	LD<>	LD activates if (S1) ≠ (S2)
	LD<=	LD activates if (S1) ≤ (S2)
	LD>=	LD activates if (S1) ≥ (S2)
	AND=	AND activates if (S1) = (S2)
	AND>	AND activates if (S1) > (S2)
	AND<	AND activates if (S1) < (S2)
	AND<>	AND activates if (S1) ≠ (S2)
	AND<=	AND activates if (S1) ≤ (S2)
	AND>=	AND activates if (S1) ≥ (S2)
	OR=	OR activates if (S1) = (S2)
	OR>	OR activates if (S1) > (S2)
	OR<	OR activates if (S1) < (S2)
	OR<>	OR activates if (S1) ≠ (S2)
Data Move	MOV	Move
	BMOV	Block move
	FMOV	Fill move
	FWRT	FlashROM written
	MSET	Zone set
	ZRST	Zone reset

	SWAP	The high and low byte of the destinated devices are exchanged
	XCH	Exchange
Data Operation	ADD	Addition
	SUB	Subtraction
	MUL	Multiplication
	DIV	Division
	INC	Increment
	DEC	Decrement
	MEAN	Mean
	WAND	Word And
	WOR	Word OR
	WXOR	Word exclusive OR
	CML	Compliment
	NEG	Negative

Common statements of XC3/XC5

Data Shift	SHL	Arithmetic Shift Left
	SHR	Arithmetic Shift Right
	LSL	Logic shift left
	LSR	Logic shift right
	ROL	Rotation shift left
	ROR	Rotation shift right
	SFTL	Bit shift left
	SFTR	Bit shift right
	WSFL	Word shift left
	WSFR	Word shift right
Data Convert	WTD	Single word integer converts to double word integer
	FLT	32 bits integer converts to float point
	FLTD	64 bits integer converts to float point
	INT	Float point converts to binary
	BIN	BCD converts to binary
	BCD	Binary converts to BCD
	ASC	Hex. converts to ASCII
	HEX	ASCII converts to Hex.
	DECO	Coding
	ENCO	High bit coding
Float Point Operation	ENCOL	Low bit coding
	ECMP	Float compare
	EZCP	Float Zone compare
	EADD	Float Add
	ESUB	Float Subtract
	EMUL	Float Multiplication
	EDIV	Float division
	ESQR	Float Square Root
	SIN	Sine
	COS	Cosine
Clock Operation	TAN	Tangent
	TCMP	Time Compare
	TZCP	Time Zone Compare
	TADD	Time Add
	TSUB	Time Subtract
	TRD	Read RTC data
TWR	Set RTC data	

5-2. Reading Method of Applied Instructions

Understanding method of instruction understanding

In this manual, the applied instructions are described in the following manner.

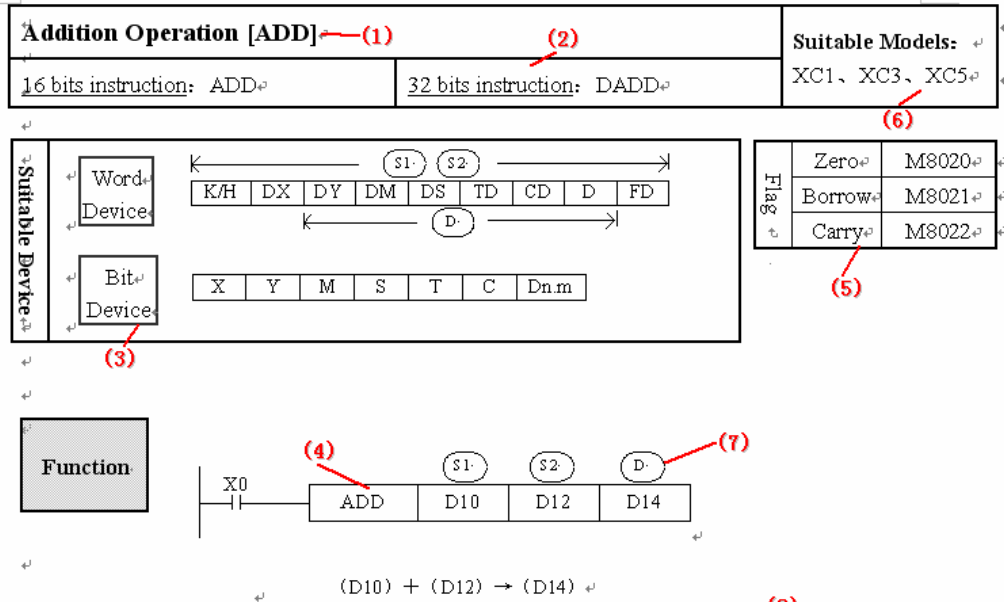

- The data contained within the two source devices are combined and the total is stored in the specified destination device. Each data's highest bit is the sign bit, 0 stands for positive, 1 stands for negative. All calculations are algebraic processed. (5+ (-8) =-3)
- If the result of a calculation is "0", the "0" flag acts. If the result exceeds 323, 767 (16 bits limit) or 2,147,483,647 (32 bits limit), the carry flag acts. (refer to the next page). If the result exceeds -323,768 (16 bits limit) or -2,147,483,648 (32 bits limit), the borrow flag acts (Refer to the next page)
- When carry on 32 bits operation, word device's low 16 bits are assigned, the device following closely the preceding device's ID will be the high bits. To avoid ID repetition, we recommend you assign device's ID to be even ID.
- The same device may be used as a source and a destination. If this is the case then the result changes after every scan cycle. Please note this point.

Note:

- ⑧ Denote the instruction name
- ⑨ 16 bits instruction and 32 bits instruction
- ⑩ Denotes the soft units which can be used as the operation object

Ladder Example

Flag after executing the instruction. Instructions without the direct flag will not display.

Suitable models for the instruction

(S?) Source operand, its content won't change after executing the instruction

(D?) Destinate operand, its content changes with the execution of the instruction

(8) Tell the instruction's basic action, using way, applied example, extend function, note items etc.

The related description

- The assignment of the data

The data register of XC series PLC is a single word (16 bit) data register, single word data only engross one data register which is assigned by single word object instruction. The disposal bound is: Dec. -327,68~327,67, Hex. 0000~FFFF.

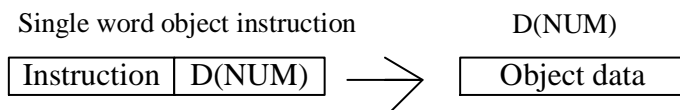

Double word(32 bit)engrosses two data register, it's composed by two consecutive data registers, the first one is assigned by double word object instruction. The dispose bound is: Dec. -214,748,364,8~214,748,364,7, Hex. 00000000~FFFFFFFF.

Double word object instruction

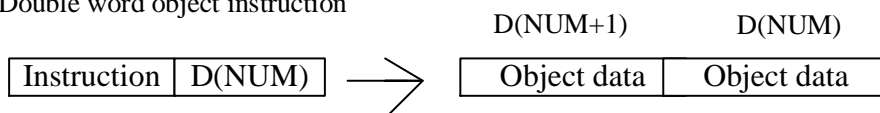

- The denote way of 32 bits instruction

If an instruction can not only be 16 bits but also be 32 bits, then the denote method for 32 bits instruction is to add a “D” before 16 bits instruction.

E.g: ADD D0 D2 D4 denotes two 16 bits data adds;

DADD D10 D12 D14 denotes two 32 bits data adds

Instructions list of 16 bits and correspond 32 bits:

	16 bits	32 bits		16 bits	32 bits
Program Flow	CJ	-	Data convert	WTD	-
	CALL	-		FLT	DFLT
	SRET	-		INT	DINT
	STL	-		BIN	DBIN
	STLE			BCD	DBCD
	SET			ASC	-
	ST			HEX	-
	FOR	-		DECO	-
	NEXT	-		ENCO	-
	FEND	-		ENCOL	-
	Data Move	MOV		DMOV	Float operation
BMOV			-	EZCP	
FMOV		-	-	EADD	
FWRT		DFWRT	-	ESUB	
ZRST		-	-	EMUL	
SWAP		-	-	EDIV	
XCH		DXCH	-	ESQR	
Data operation	ADD	DADD	-	SIN	
	SUB	DSUB	-	COS	
	MUL	DMUL		TAN	
	DIV	DDIV	Clock operation	TCMP	
	INC	DINC		TZCP	-
	DEC	DDEC		TADD	-
	MEAN	DMEAN		TSUB	-
	WAND	DWAND		TRD	-
	WOR	DWOR		TWR	-
	Data Shift	WXOR	DWXOR		
		CML	DCML		
NEG		DNEG			
SHL		DSHL			
SHR		DSHR			
LSL		DLSL			
LSR		DLSR			
ROL		DROL			
ROR		DROR			
SFTL		DSFTL			
SFTR		DSFTR			
WSFL	DWSFL				
WSFR	DWSFR				

5-3. Program Flow Instructions

➤ Mnemonic	Instruction's name
CJ	Condition Jump
CALL	Call subroutine
SRET	Subroutine return
STL	Flow start
STLE	Flow end
SET	Open the assigned flow, close the current flow (flow jump)
ST	Open the assigned flow, not close the current flow (Open the new flow)
FOR	Start of a FOR-NEXT loop
NEXT	End of a FOR-NEXT loop
FEND	First End

Condition Jump [CJ]		Suitable Models: XC1、XC3、XC5
<u>16 bits instruction:</u> CJ	<u>32 bits instruction:</u> -	
Suitable Device	Pointer: P	
	Soft Unit's Bound: P0~P9999	

Function and Action

As the instructions of executing list, with CJ instructions, the operate cycle and dual coil can be greatly shorten.

In the following chart, if X000" ON", then jump from step 1 to the end step of flag P6. When X000" OFF" , do not execute jump instructions.

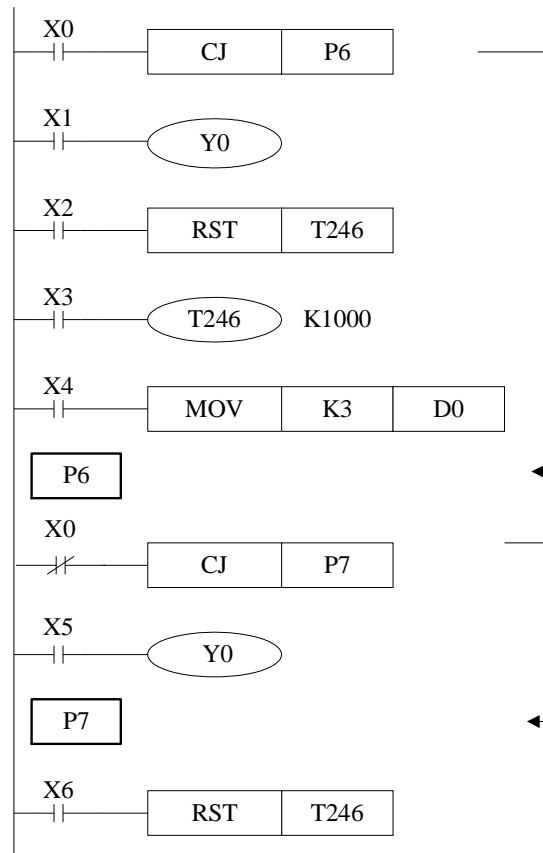

- See the upward graph, Y000 turns to be dual coil and output. But when X000=OFF, X001 activates. When X000=ON, X005 activates.
- CJ can not jump from one STL to another STL.
- If program timer T0~T640 and high speed counter C600~C640 jump after driving, go on working, output point also activate.

Call subroutine [CALL] and Subroutine return [SRET]		Suitable Models: XC1、XC3、XC5
<u>16 bits instruction:</u> CALL、SRET	<u>32 bits instruction:</u> -	

Suitable Device	Pointer: P Soft Unit's Bound: P0~P9999
------------------------	---

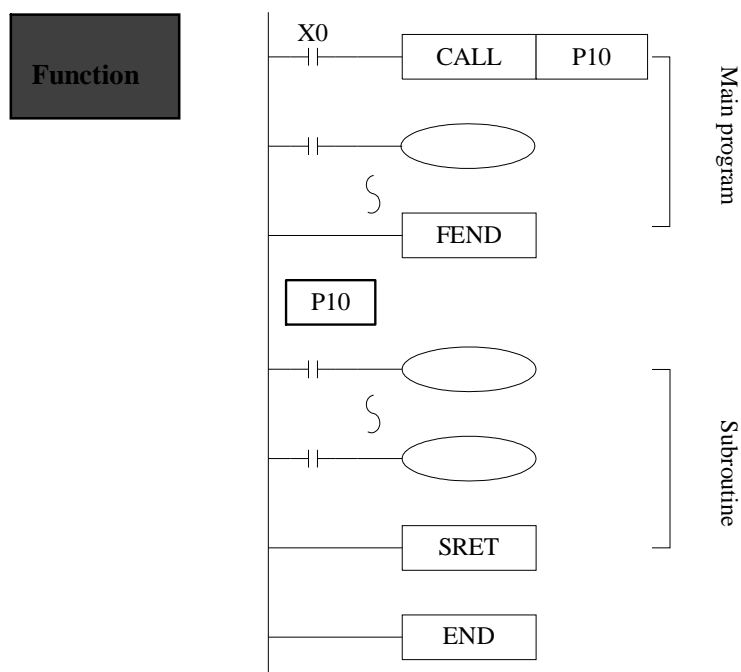

- If X000“ ON” , carry on Jump instruction and jump to step of flag P10. Here, after executing the subroutine, return to the original step via executing SRET instruction. After the following FEND instruction, program with the flag.
- In the subroutine, 9 levels Call instruction is allowed, so to the all, 10 levels nesting is available.

Flow [SET]、[ST]、[STL]、[STLE]		Suitable Models: XC1、XC3、XC5
<u>16 bits instruction:</u> SET、ST、STL、STLE	<u>32 bits instruction:</u> -	
Suitable Device	Pointer: S	
	Soft Unit's Bound: S0~S	

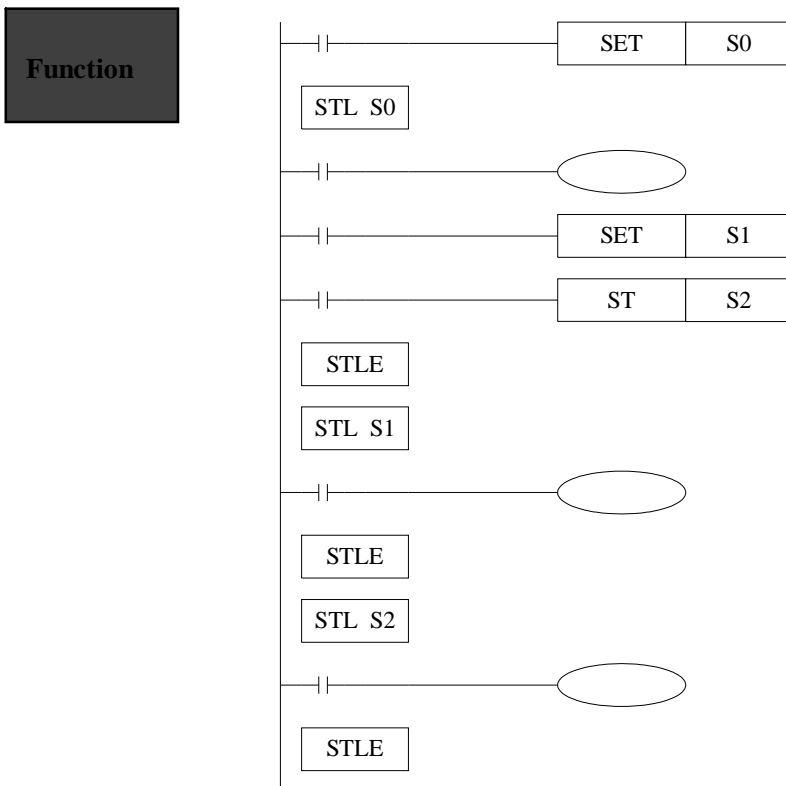

- STL and STLE should be used in pairs. STL means start of a flow, STLE means end of a flow.
- After executing of SET Sxxx instruction, the flow assigned by these instructions is ON.
- After executing of RST Sxxx instruction, the assigned flow is OFF.
- In flow S0, SET S1 close the current flow S0, open flow S1.
- In flow S0, ST S2 open the flow S2, but don't close flow S0.
- When flow turns from ON to be OFF, OFF or reset OUT、PLS、PLF、not accumulate timer etc. which belongs to the flow.
- ST instruction is usually used when a program needs to run more flows at the same time.
- In a main program, usually use ST instruction to open a flow.

[FOR] AND [NEXT]		Suitable Models: XC1、XC3、XC5
16 bits instruction: FOR、NEXT	32 bits instruction: -	

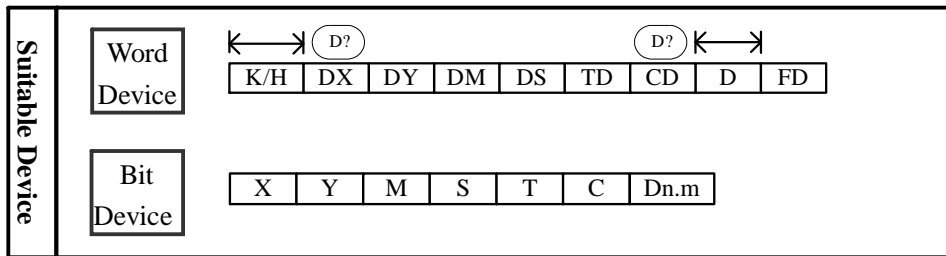

Function

First execute the instructions between FOR~NEXT instructions for several times (the loop time is assigned by the source data), then execute the steps after NEXT.

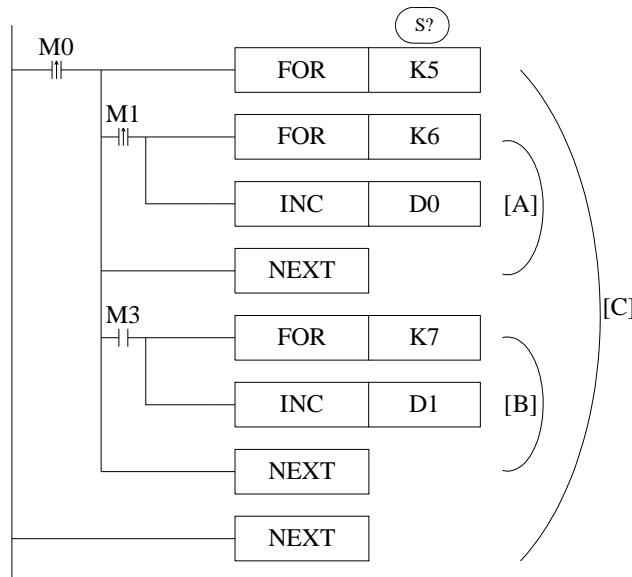

- FOR、NEXT instructions must be programmed as a pair. Nesting is allowed, and the nesting level is 8.
- Between FOR/NEXT, LDP、LDF instructions are effective for one time. Every time when M0 turns from OFF to ON, and M1 turns from OFF to ON, [A] loop is executed 6 times.
- Every time if M0 turns from OFF to ON and M3 is ON, [B] loop is executed 5? 7=35 times.
- If there are many loop times, the scan cycle will be prolonged. Monitor timer error may occur, please note this.
- If NEXT is before FOR, or no NEXT, or NEXT is behind FENG, END, or FOR and NEXT number is not equal, an error will occur.
- Between FOR~NEXT, CJ nesting is not allowed, also in one STL, FOR~NEXT must be programmed as a pair.

[FEND] AND [END]		Suitable Models: XC1、XC3、XC5
16 bits instruction: FEND、END	32 bits instruction: -	

Suitable Device	None
-----------------	------

Function

An FEND instruction indicates the first end of a main program and the start of the program area to be used for subroutines. Under normal operating circumstances the FEND instruction performs a similar action to the END instruction, i.e. output processing, input processing and watchdog timer refresh are all carried out on execution.

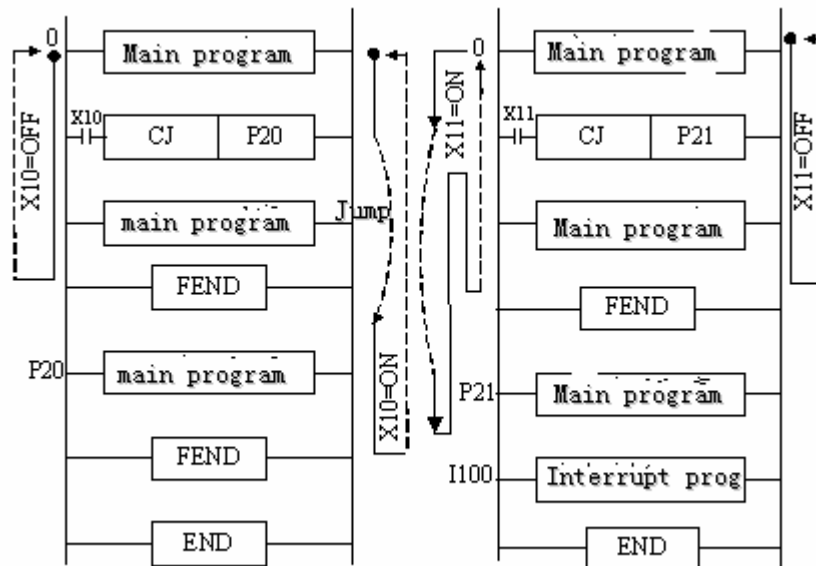

- If program the tag of CALL instruction behind FEND instruction, there must be SRET instruction. If the interrupt pointer program behind FEND instruction, there must be SRET instruction.
- After executing CALL instruction and before executing SRET instruction, if execute FEND instruction; or execute FEND instruction after executing FOR instruction and before executing NEXT, then an error will occur.
- In the condition of using many FEND instruction, please compile routine or subroutine between the last FEND instruction and END instruction.

5-4. Contactor's Compare Instructions

Mnemonic & Function

Mnemonic	➤ Function
LD=	Initial comparison contact. Active when the comparison $(S1)=(S2)$ is true.
LD>	Initial comparison contact. Active when the comparison $(S1)>(S2)$ is true
LD<	Initial comparison contact. Active when the comparison $(S1)<(S2)$ is true
LD<>	Initial comparison contact. Active when the comparison $(S1)\neq(S2)$ is true
LD<=	Initial comparison contact. Active when the comparison $(S1)\leq(S2)$ is true
LD>=	Initial comparison contact. Active when the comparison $(S1)\geq(S2)$ is true
AND=	Serial comparison contact. Active when the comparison $(S1)=(S2)$ is true.
AND>	Serial comparison contact. Active when the comparison $(S1)>(S2)$ is true.
AND<	Serial comparison contact. Active when the comparison $(S1)<(S2)$ is true.
AND<>	Serial comparison contact. Active when the comparison $(S1)\neq(S2)$ is true.
AND<=	Serial comparison contact. Active when the comparison $(S1)\leq(S2)$ is true.
AND>=	Serial comparison contact. Active when the comparison $(S1)\geq(S2)$ is true.
OR=	Parallel comparison contact. Active when the comparison $(S1)=(S2)$ is true.
OR>	Parallel comparison contact. Active when the comparison $(S1)>(S2)$ is true.
OR<	Parallel comparison contact. Active when the comparison $(S1)<(S2)$ is true.
OR<>	Parallel comparison contact. Active when the comparison $(S1)\neq(S2)$ is true.
OR<=	Parallel comparison contact. Active when the comparison $(S1)\leq(S2)$ is true.
OR>=	Parallel comparison contact. Active when the comparison $(S1)\geq(S2)$ is true.

Initial Comparison LD □		Suitable Models: XC1、XC3、XC5
<u>16 bits instruction:</u> Refer Below	<u>32 bits instruction:</u> Refer Below	

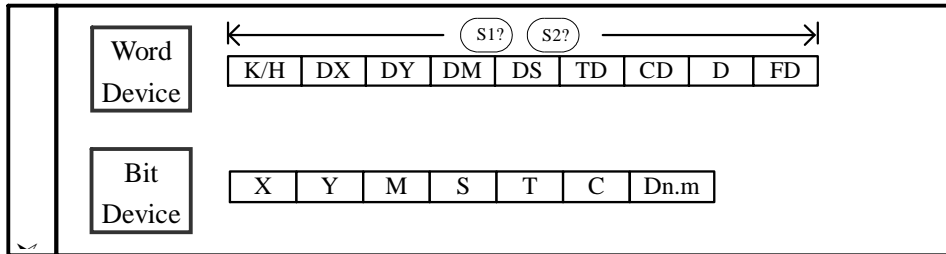

Instruction & Function

The value of S1 and S2 are tested according to the comparison of the instruction. If the comparison is true then the LD contact is active. If the comparison is false then the LD contact is not active.

16 bits	➤ 32 bits	➤ Active condition	➤ Inactive condition
LD =	DLD =	(S1) = (S2)	(S1) ≠ (S2)
LD >	DLD >	(S1) > (S2)	(S1) ≤ (S2)
LD <	DLD <	(S1) < (S2)	(S1) ≥ (S2)
LD < >	DLD < >	(S1) ≠ (S2)	(S1) = (S2)
LD < =	DLD < =	(S1) ≤ (S2)	(S1) > (S2)
LD > =	DLD > =	(S1) ≥ (S2)	(S1) < (S2)

Program

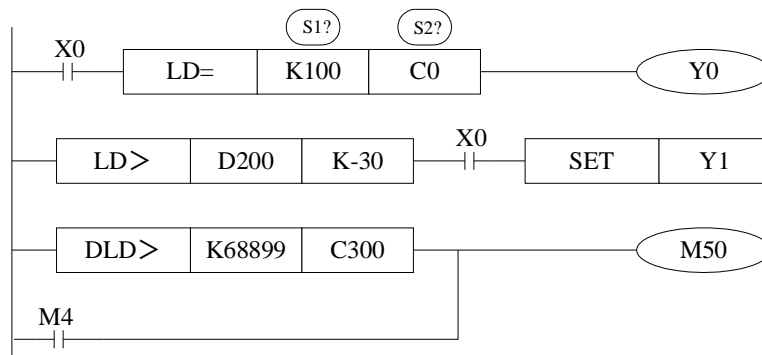

Note Items

- When the source data's highest bit (16 bits: b15, 32 bits: b31) is 1, use the data as a negative.
- The comparison of 32 bits counter (C300~) must use 32 bits instruction. If assigned as 16 bits instruction, it will lead the program error or operation error.

Serial Refer Below AND □		Suitable Models: XC1、XC3、XC5
16 bits instruction: Refer Below	32 bits instruction: Refer Below	

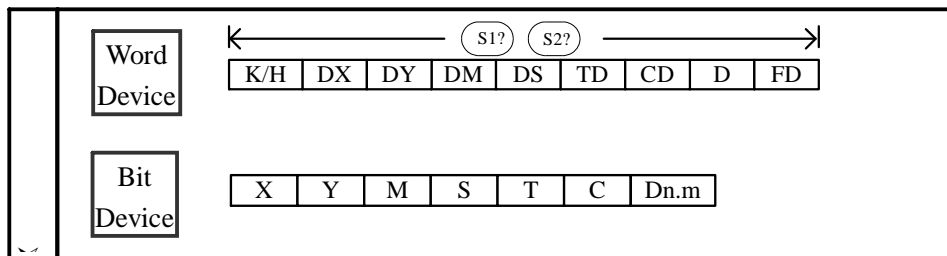

Instruction & Function

The value of S1 and S2 are tested according to the comparison of the instruction. If the comparison is true then the LD contact is active. If the comparison is false then the LD contact is not active.

16 bits	➤ 32 bits	➤ Active condition	➤ Inactive condition
AND =	DAND=	(S1) = (S2)	(S1) ≠ (S2)
AND >	DAND>	(S1) > (S2)	(S1) ≤ (S2)
AND <	DAND<	(S1) < (S2)	(S1) ≥ (S2)
AND	DAND<>	(S1) ≠ (S2)	(S1) = (S2)
Program	AND<=	(S1) ≤ (S2)	(S1) > (S2)
AND >=	DAND>=	(S1) ≥ (S2)	(S1) < (S2)

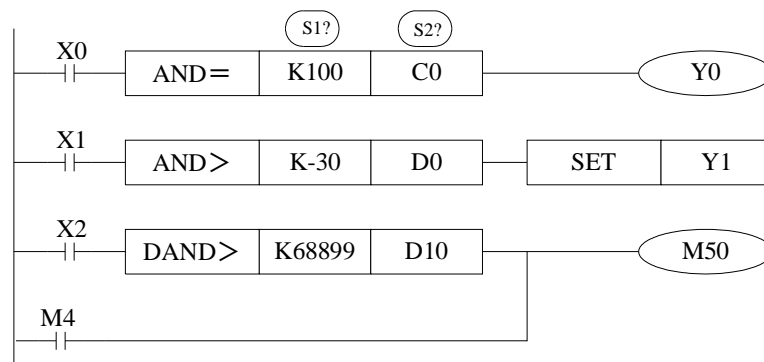

Note Items

- When the source data's highest bit (16 bits: b15, 32 bits: b31) is 1, use the data as a negative.
- The comparison of 32 bits counter (C300~) must use 32 bits instruction. If assigned as 16 bits instruction, it will lead the program error or operation error.

Parallel Comparison OR <input type="checkbox"/>		Suitable Models: XC1、XC3、XC5
<u>16 bits instruction:</u> Refer Below	<u>32 bits instruction:</u> Refer Below	

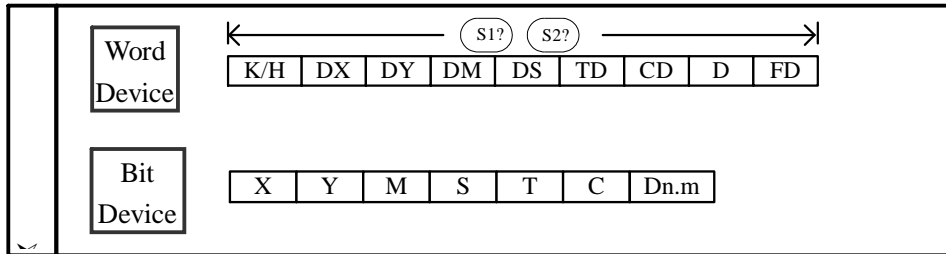

Instruction & Function

The value of S1 and S2 are tested according to the instruction. If the comparison is true then the AND contact is active. If the comparison is false then the AND contact is not active.

16 bits	32 bits	Active condition	Inactive condition
AND=	DAND=	(S1) = (S2)	(S1) ≠ (S2)
AND>	DAND>	(S1) > (S2)	(S1) ≤ (S2)
AND<	DAND<	(S1) < (S2)	(S1) ≥ (S2)
AND<>	DAND<>	(S1) ≠ (S2)	(S1) = (S2)
AND≤	DAND≤	(S1) ≤ (S2)	(S1) > (S2)
AND≥	DAND≥	(S1) ≥ (S2)	(S1) < (S2)

Program

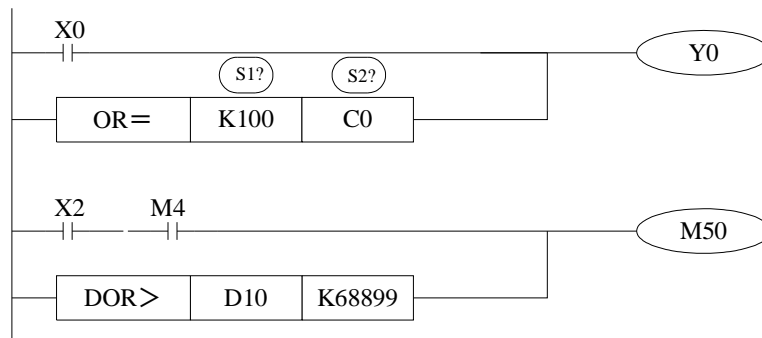

Note Items

- When the source data's highest bit (16 bits: b15, 32 bits: b31) is 1, use the data as a negative.
- The comparison of 32 bits counter (C300~) must be 32 bits instruction. If assigned as a 16 bits instruction, it will lead the program error or operation error.

5-5. Data Move

Mnemonic	Function
MOV	Move
BMOV	Block Move
FMOV	Fill Move
FWRT	Written of FlashROM
MSET	Zone Set
ZRST	Zone Reset
SWAP	Float To Scientific
XCH	Exchange

[MOV]		Suitable Models: XC1、XC3、XC5
<u>16 bits instruction:</u> MOV	<u>32 bits instruction:</u> DMOV	

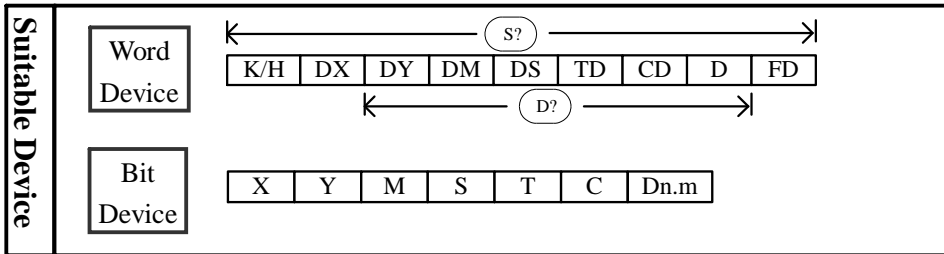

Function & Action

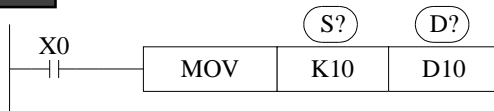

Move data from one storage area to a new one.

- Move contents from source to destination
- If X000 is OFF, data will not change.
- Constant K10 will automatically convert to be BIN code.

《Read out the current value of timer、 counter》

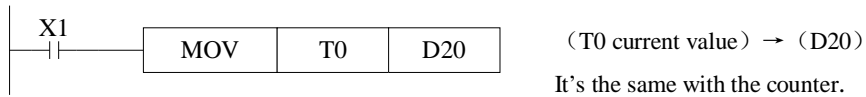

《Indirect assign the set value of timer、 counter》

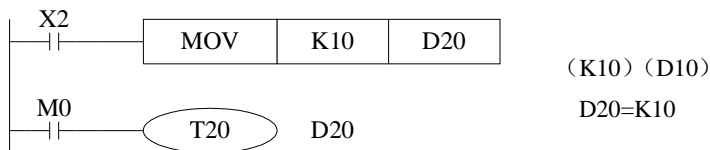

《Move of 32 bits data》

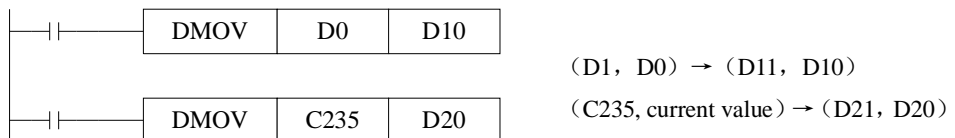

[BMOV]		Suitable Models: XC1、XC3、XC5
16 bits instruction: BMOV	32bits instruction: -	

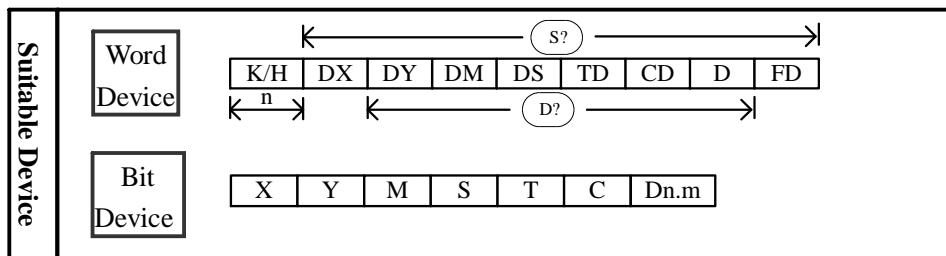

Function

- A quantity of consecutively occurring data elements can be copied to a new destination. The source data is identified as a device head address(S) and a quantity of consecutive data elements (n). This is moved to the destination device (D) for the same number of elements (n). (If the quantity of source device (n) exceeds the actual number of available source devices, then only those devices which fall in the available range will be used. If the number of source devices exceeds the available space at the destination location, then only the available destination devices will be written to.)

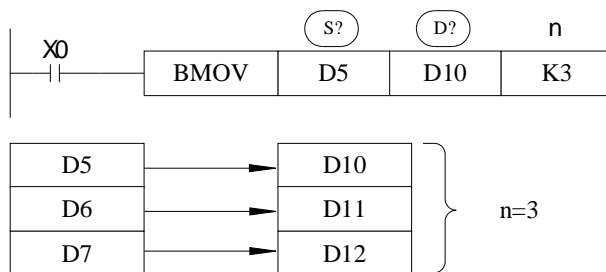

- The BMOV instruction has a built in automatic feature to prevent overwriting errors from occurring when the source (S-n) and destination (D-n) data ranges coincide. This is clearly identified in the following diagram:
- (NOTE: The numbered arrows indicate the order in which the BMOV is processed).

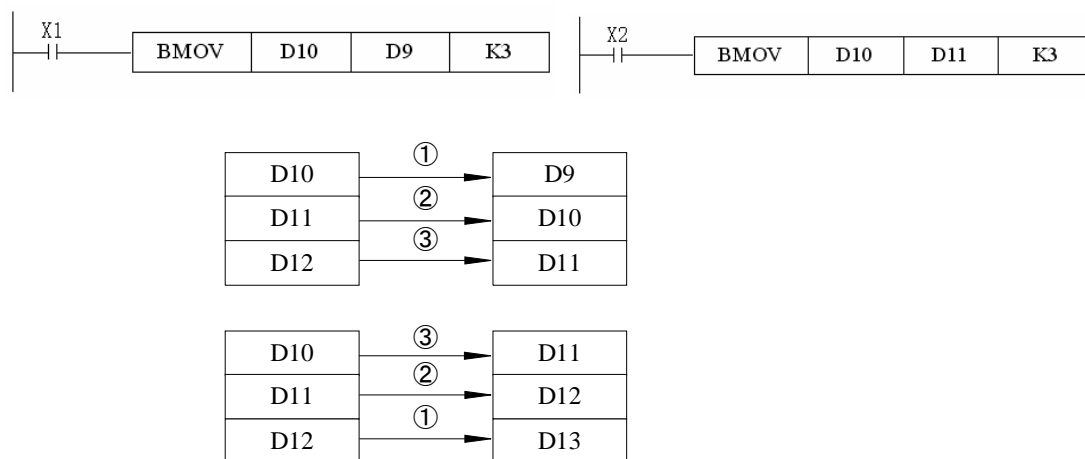

[FMOV]		Suitable Models: XC1、XC3、XC5
<u>16 bits instruction:</u> FMOV	<u>32 bits instruction:</u> -	

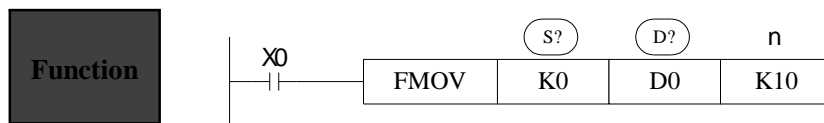
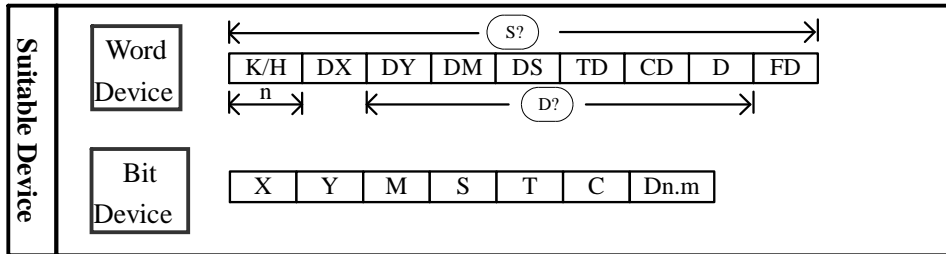

- Move K0 to D0~D9. Copy a single data device to a range of destination devices.
- The data stored in the source device (S) is copied to every device within the destination range, The range is specified by a device head address (D) and a quantity of consecutive elements (n).
- If the specified number of destination devices (n) exceeds the available space at the destination location, then only the available destination devices will be written to.

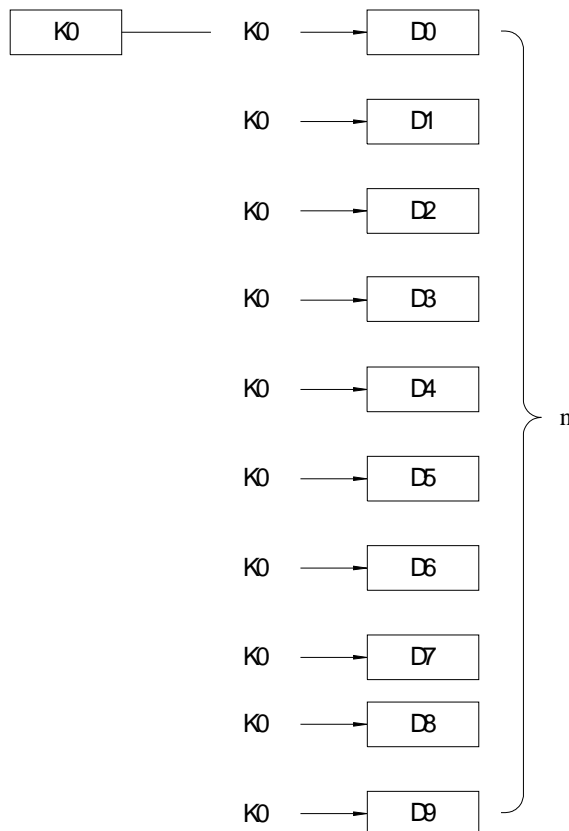

[FWRT]		Suitable Models: XC1、XC3、XC5
<u>16 bits instruction:</u> FWRT	<u>32 bits instruction:</u> DFWRT	

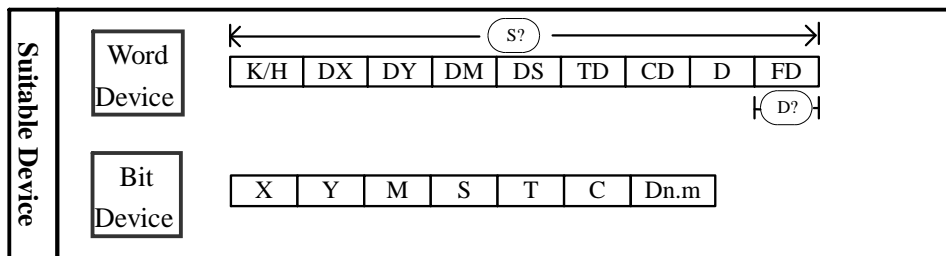

Function

1、Written of a word

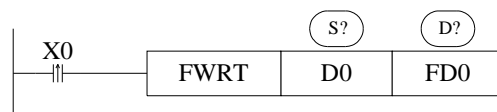

Function: write value in D0 into FD0

2、Written of double word

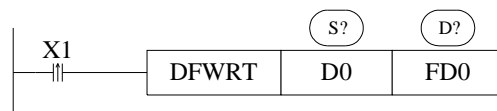

Function: write value in D0、D1 into FD0、FD1

3、Written of multi-word

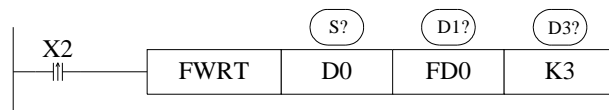

Function: write value in D0、D2、D3 into FD0、FD1、FD2.

- Note: 1, FWRT instruction only allow to write data into FlashROM register. In this storage area, even battery drop, data could be stored. So it could be used to store important technical parameters.
- 2, Written of FWRT needs a long time, about 150ms, so, frequently operate this operation is not recommended.
- 3, The written time of FlashROM is about 1,000,000 times. So, we suggest using edge signals (LDP、LDF etc.) to trigger.
- ※ Frequently written of FlashROM will ruin FlashROM forever.

[MSET]		Suitable Models: XC1、XC3、XC5
16 bits instruction: MSET	32 bits instruction: -	

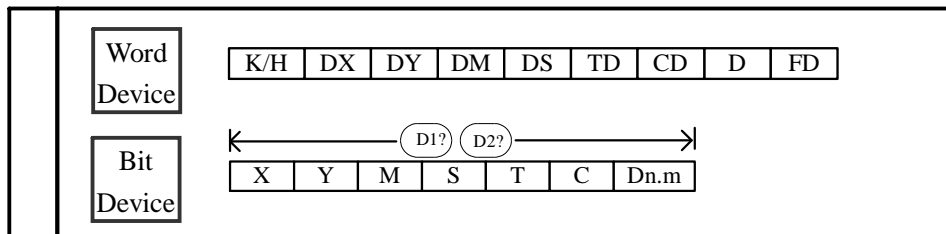

[ZRST]		Suitable Models: XC1、XC3、XC5
16 bits instruction: ZRST	32 bits instruction: -	

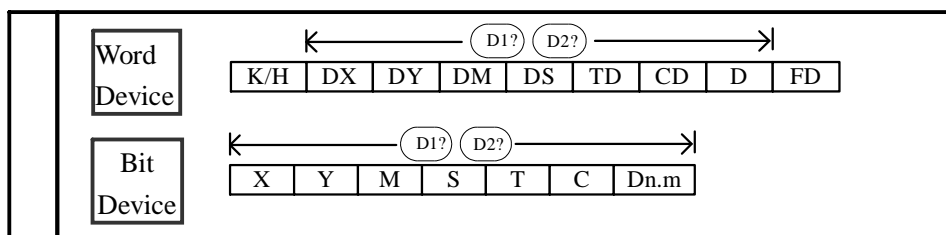

Function & Action

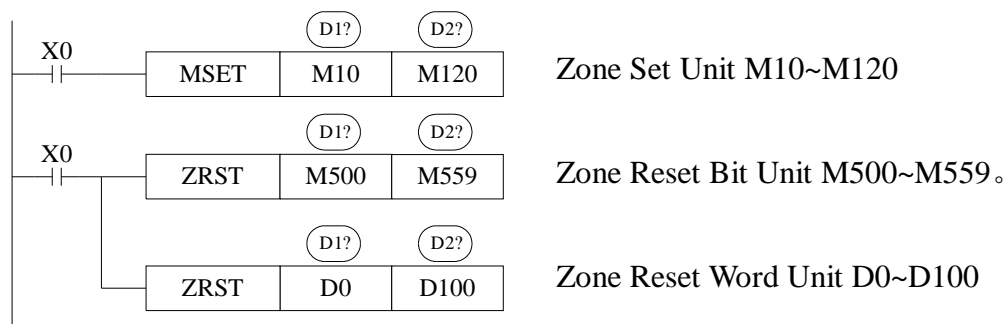

- (D1?) (D2?) Are specified as the same type of soft units, and (D1?) < (D2?)
When (D1?) > (D2?) , only reset the soft unit specified in (D1?)

Other Reset Instruction

- As soft unit's separate reset instruction, RST instruction can be used to bit unit Y, M, S and word unit T, C, D.
- As fill move for constant K0, 0 can be written into DX, DY, DM, DS, T, C, D.

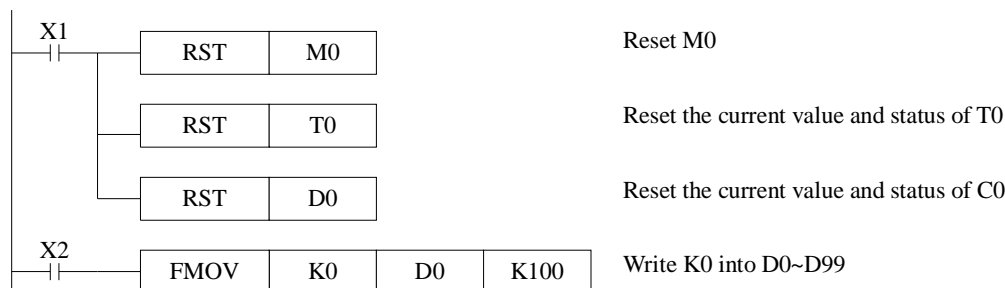

[SWAP]		Suitable Models: XC1、XC3、XC5
<u>16bits instruction:</u> SWAP	<u>32 bits instruction:</u> -	

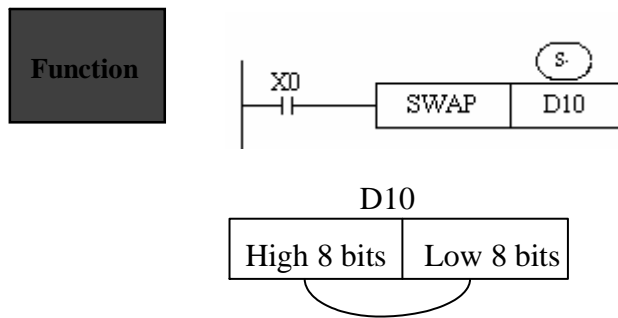
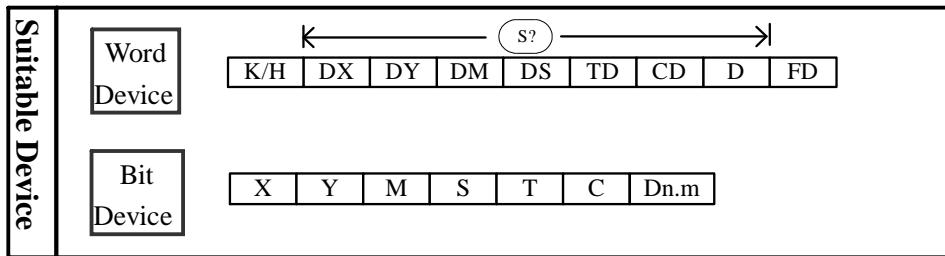

- Low 8 bits and high 8 bits change when it is 16 bits instruction.
- If the instruction is a consecutive executing instruction, each operation cycle should change.

[XCH]		Suitable Models: XC1、XC3、XC5
16 bits instruction: XCH	32 bits instruction: DXCH	

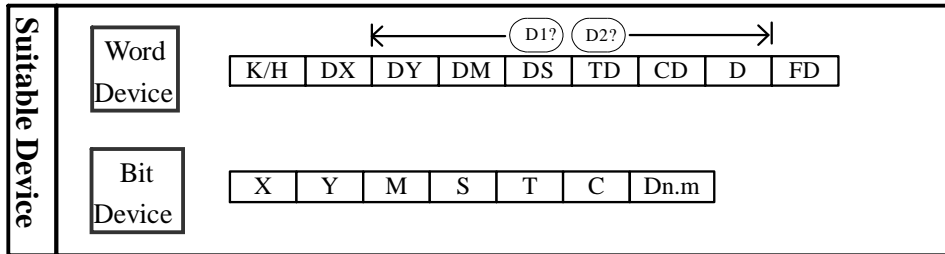

Function

《16 bits instruction》

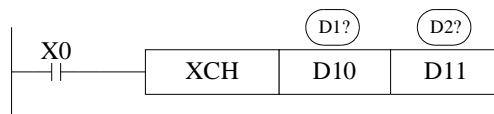

Before (D10) =100 → After (D10) =101
 (D11) =101 (D11) =100

- The contents of the two destination devices D1 and D2 are swapped,
- When drive input X0 is ON, each scan cycle should carry on data exchange.

《32 bits instruction》

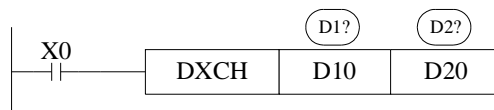

- 32 bits instruction [DXCH] swaps value composed by D10、D11 and the value composed by D20、D21.

5-6. Data Operation Instructions

Mnemonic	Function
ADD	Addition
SUB	Subtraction
MUL	Multiplication
DIV	Division
INC	Increment
DEC	Decrement
MEAN	Mean
WAND	Logic Word And
WOR	Logic Word Or
WXOR	Logic Exclusive Or
CML	Compliment
NEG	Negation

Addition Operation [ADD]		Suitable Models: XC1、XC3、XC5
<u>16 bits instruction:</u> ADD	<u>32 bits instruction:</u> DADD	

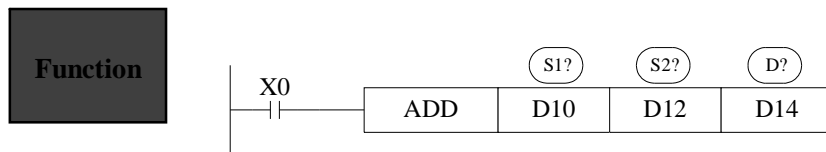
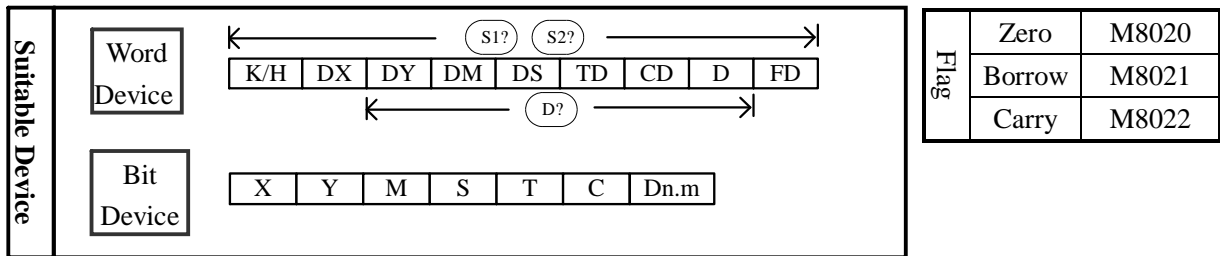

$$(D10) + (D12) \rightarrow (D14)$$

- The data contained within the two source devices are combined and the total is stored in the specified destination device. Each data's highest bit is the sign bit, 0 stands for positive、1 stands for negative. All calculations are algebraic processed. (5+ (-8) =-3)
- If the result of a calculation is "0", the "0" flag acts. If the result exceeds 323, 767 (16 bits limit) or 2,147,483,647 (32 bits limit) , the carry flag acts. (refer to the next page) . If the result exceeds -323,768 (16 bits limit) or -2,147,483,648 (32 bits limit) , the borrow flag acts (Refer to the next page)
- When carry on 32 bits operation, word device's low 16 bits are assigned, the device following closely the preceding device's ID will be the high bits. To avoid ID repetition, we recommend you assign device's ID to be even ID.
- The same device may be used as a source and a destination. If this is the case then the result changes after every scan cycle. Please note this point.

[SUB]		Suitable Models: XC1、XC3、XC5
16 bits instruction: SUB	32 bits instruction: DSUB	

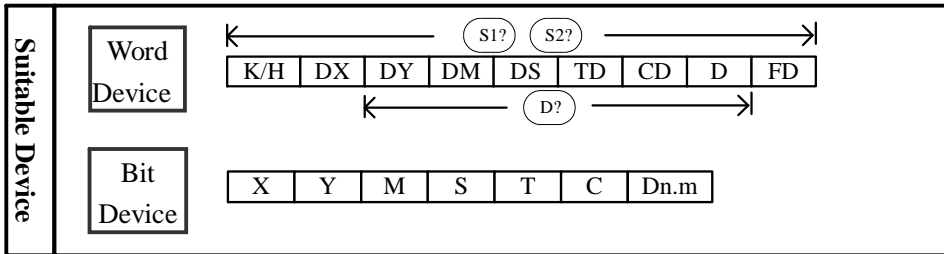

Flag	Zero	M8020
	Borrow	M8021
	Carry	M8022

Function

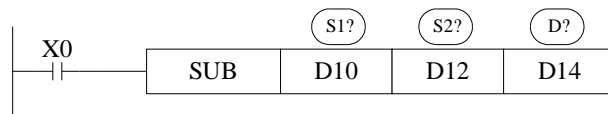

$(D10) - (D12) \rightarrow (D14)$

- $(S1?)$ appoint the soft unit's content, subtract the soft unit's content appointed by $(S2?)$ in the format of algebra. The result will be stored in the soft unit appointed by $(D?)$. $(5 - (-8) = 13)$
- The action of each flag, the appointment method of 32 bits operation's soft units are both the same with the preceding ADD instruction.
- The importance is: in the preceding program, if X0 is ON, SUB operation will be executed every scan cycle

The relationship of the flag's action and vale's positive/negative is shown below:

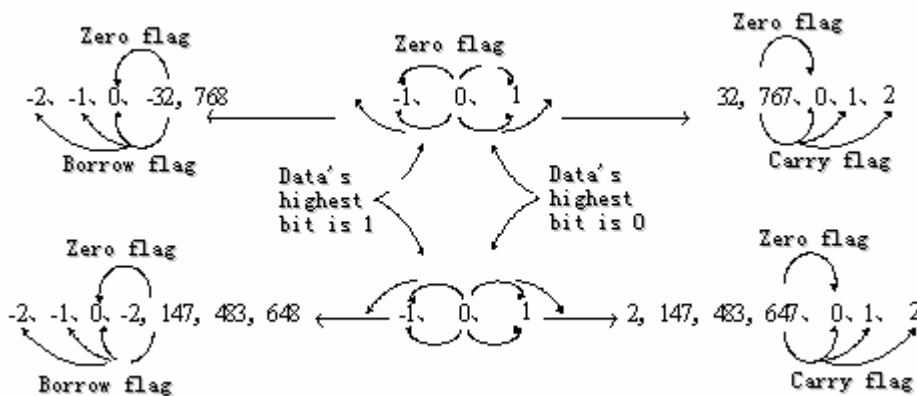

[MUL]		Suitable Models: XC1、XC3、XC5
16 bits instruction: MUL	32 bits instruction: DMUL	

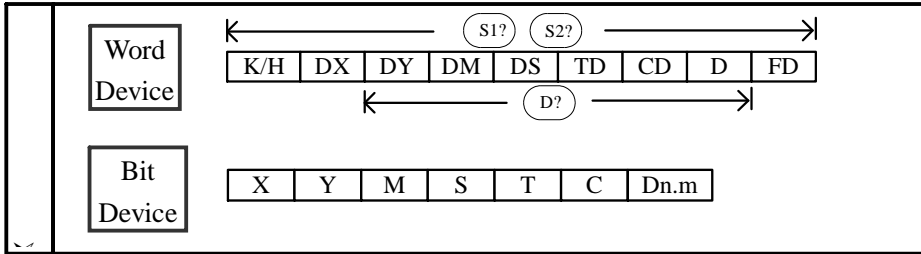

Flag	Zero	M8020
	Borrow	M8021
	Carry	M8022

Function & action

《16 bits operation》

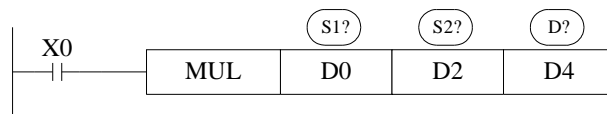

BIN BIN BIN
 (D0) ? (D2) → (D5, D4)
 16 bits 16 bits → 32 bits

- The contents of the two source devices are multiplied together and the result is stored at the destination device in the format of 32 bits. As in the upward chart: when (D0)=8、(D2)=9, (D5, D4) =72.
- The result's highest bit is the symbol bit: positive (0)、negative (1).
- When the bit unit, it can carry on the bit appointment of K1~K8. When appoint K4, only the result's low 16 bits can be obtained.

《32 bits operation》

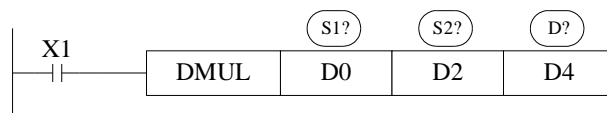

BIN BIN BIN
 (D1, D0) ? (D3, D2) → (D7, D6, D5, D4)
 32 bits 32 bits → 64 bits

- In 32 bits operation, when use bit device as the destination address, only low 32 bits result can be obtained. The high 32 bits result can not be obtained, so please operate again after transfer one time to the word device
- Even use word device, 64 bits results can't be monitored at once.
- In this situation, float point data operation is recommended.

[DIV]		特殊功能 Suitable Models:
16 bits instruction: DIV	32 bits instruction: DDIV	XC1、XC3、XC5

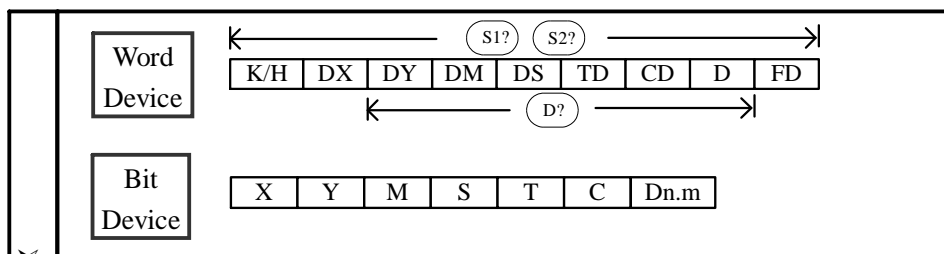

Flags	Zero	M8020
	Borrow	M8021
	Carry	M8022

Function & Action

《16 bits operation》

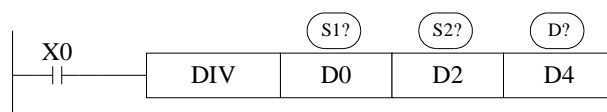

Dividend	Divisor	Result	Remainder
BIN	BIN	BIN	BIN
(D0) ?	(D2) →	D4) ---	(D5)
16 bits	16 bits	16 bits	16 bits

- (S1?) appoints the device's content be the dividend, (S2?) appoints the device's content be the divisor, (D?) appoints the device and the next one to store the result and the remainder.
- In the above example, if input X0 is ON, division operation is executed every scan cycle.

《32 bits operation》

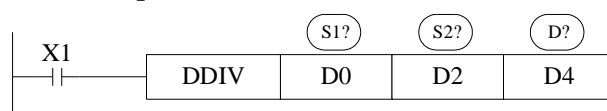

Dividend	Divisor	Result	Remainder
BIN	BIN	BIN	BIN
(D1,D0) ?	(D3,D2)	(D5,D4) ---	(D7,D6)
32 bits	32 bits	32 bits	32 bits

- The dividend is composed by the device appointed by (S1?) and the next one. The divisor is composed by the device appointed by (S2?) and the next one. The result and the remainder are stored in the four sequential devices, the first one is appointed by (D?)
- If the value of the divisor is 0, then an operation error is executed and the operation of the DIV instruction is cancelled.
- The highest bit of the result and remainder is the symbol bit (positive:0, negative: 1). When any of the dividend or the divisor is negative, then the result will be negative. When the dividend is negative, then the remainder will be negative.

[INC] & [DEC]		Suitable Models: XC1、XC3、XC5
16 bits instruction: INC、DEC	32 bits instruction: DINC、DDEC	

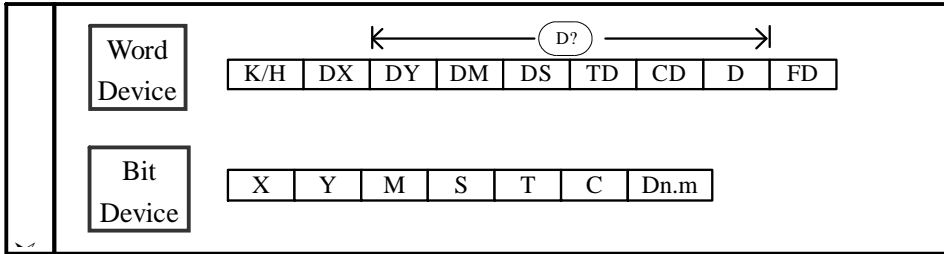

Flag	Zero	M8020
	Borrow	M8021
	Carry	M8022

Function & Action

1、Increment [INC]

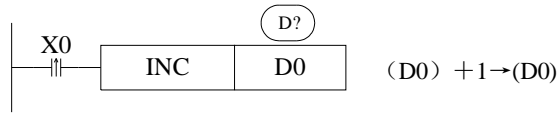

- On every execution of the instruction the device specified as the destination (D?) has its current value incremented (increased) by a value of 1.
- In 16 bits operation, when +32, 767 is reached, the next increment will write -32, 767 to the destination device. In this case, there's no additional flag to identify this change in the counted value.

2、Decrement [DEC]

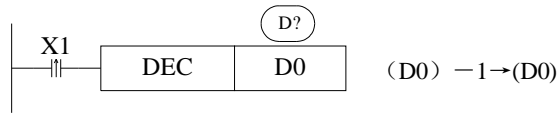

- On every execution of the instruction the device specified as the destination (D?) has its current value decremented (decreased) by a value of 1.
- When -32, 768 or -2, 147, 483, 648 is reached, the next decrement will write +32, 767 or +2, 147, 483, 647 to the destination device.

[MEAN]		Suitable Models: XC1、XC3、XC5
<u>16 bits instruction:</u> MEAN	<u>32 bits instruction:</u> -	

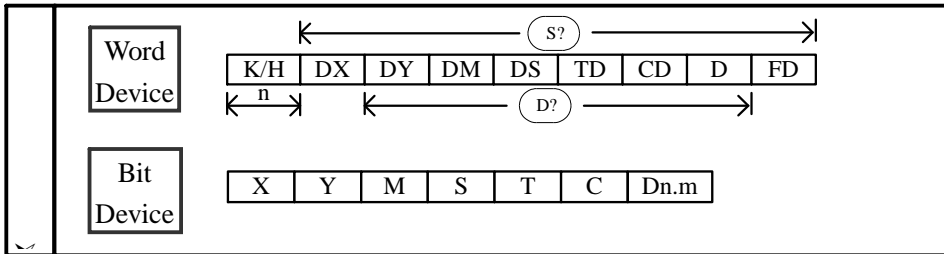

Flags	Zero	M8020
	Borrow	M8021
	Carry	M8022

Function & Action

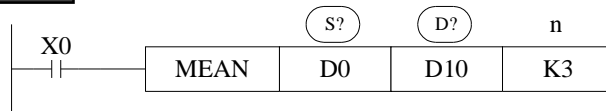

$$\frac{(D0) + (D1) + (D2)}{3} \longrightarrow (D10)$$

- The value of all the devices within the source range is summed and then divided by the number of devices summed, i.e. n.. This generates an integer mean value which is stored in the destination device (D) The remainder of the calculated mean is ignored.
- If the value of n is specified outside the stated range (1 to 64) an error is generated.

[WAND], [WOR] & [WXOR]		Suitable Models: XC1, XC3, XC5
<u>16 bits instruction:</u> WAND、WOR	<u>32 bits instruction:</u> DWAND、DWOR	

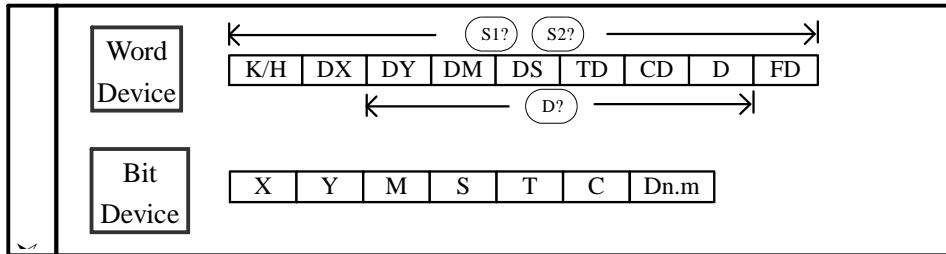

Flags	Zero	M8020
	Borrow	M8021
	Carry	M8022

Function & Action

- Execute logic AND operation with each bit

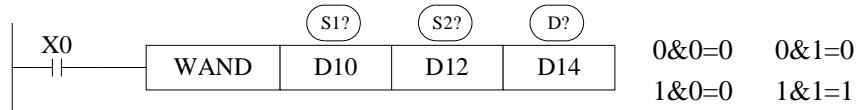

- Execute logic OR operation with each bit

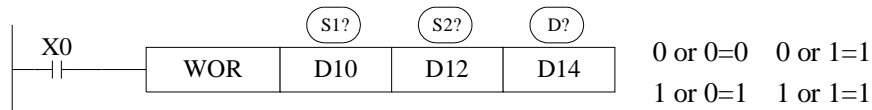

- Execute logic Exclusive OR operation with each bit.

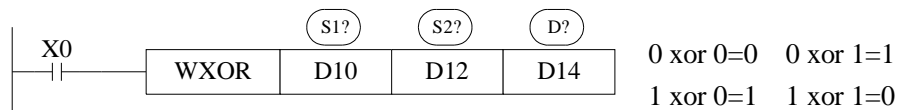

If use this instruction along with CML instruction, XOR NOT operation could also be executed.

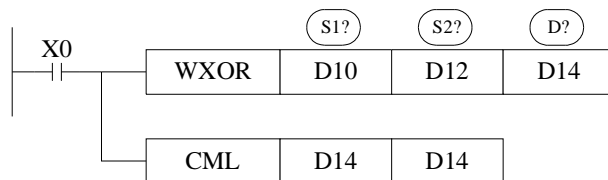

[CML]		Suitable Models: XC1、XC3、XC5
16 bits instruction: CML	32 bits instruction: DCML	

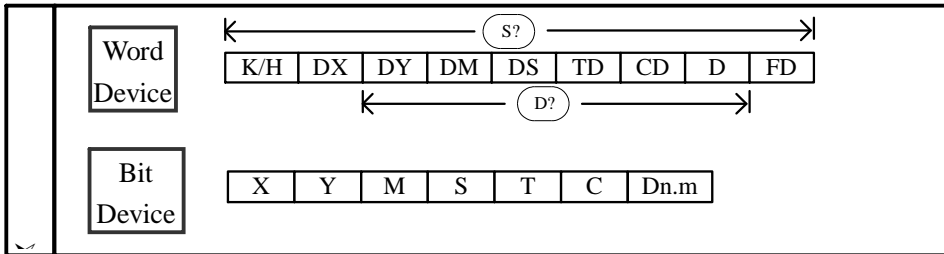

Function & Action

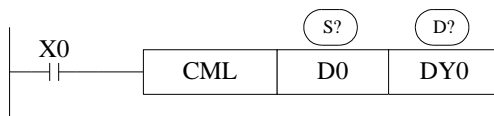

A copy of each data bit within the source device is inverted and then moved to the designated destination.

- Each data bit in the source device is inverted (0->1, 1->0) and sent to the destination device. If use constant K in the source device, it can be auto convert to be binary.
- It's available when you want to inverted output the PLC's output

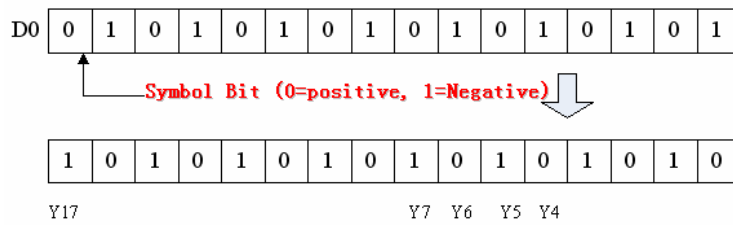

《Reading of inverted input》

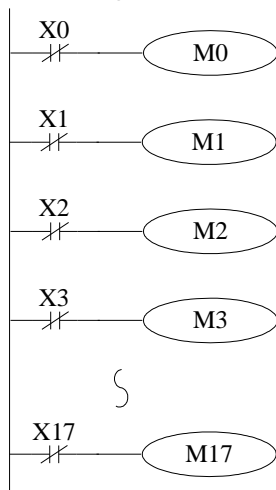

The sequential control instruction in the left could be denoted by the following CML instruction.



[NEG]		Suitable Models: XC1、XC3、XC5
<u>16 bits instruction:</u> NEG	<u>32 bits instruction:</u> DNEG	

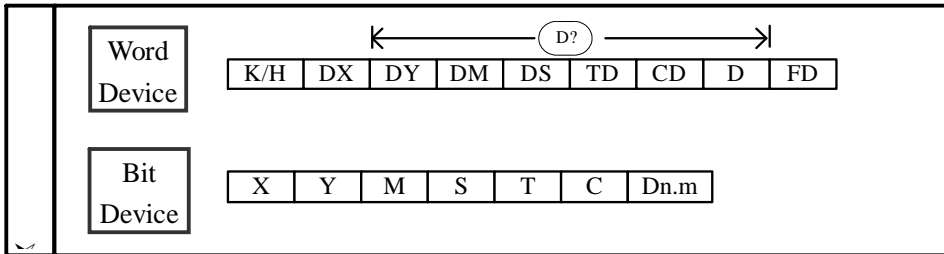

Function & Action

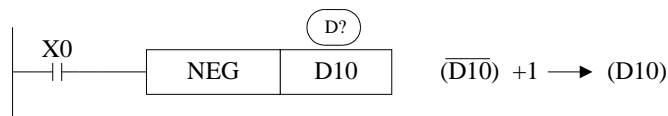

- The bit format of the selected device is inverted, I.e. any occurrence of a “1” becomes a “0” and any occurrence of “0” becomes “1”, when this is complete, a further binary 1 is added to the bit format. The result is the total logic sign change of the selected devices contents.

5-7. Shift Instructions

Mnemonic	➤ Function
SHL	Arithmetic shift left
SHR	Arithmetic shift right
LSL	Logic shift left
LSR	Logic shift right
ROL	Rotation left
ROR	Rotation right
SFTL	Bit shift left
SFTR	Bit shift right
WSFL	Word shift left
WSFR	Word shift right

[SHL] & [SHR]		Suitable Models:
<u>16 bits instruction:</u> SHL、SHR	<u>32 bits instruction:</u> DSHL、DSHR	XC3、XC5

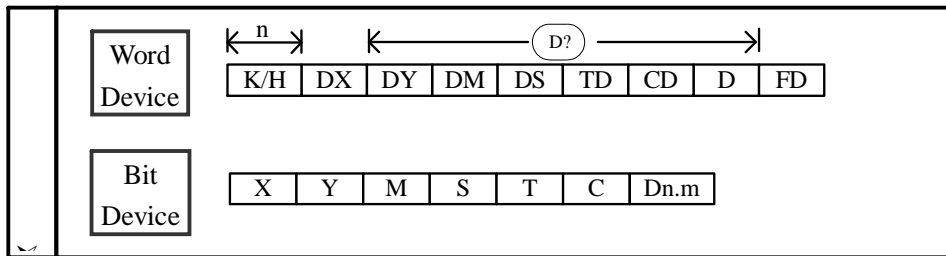

Function & Action

《Arithmetic shift left》

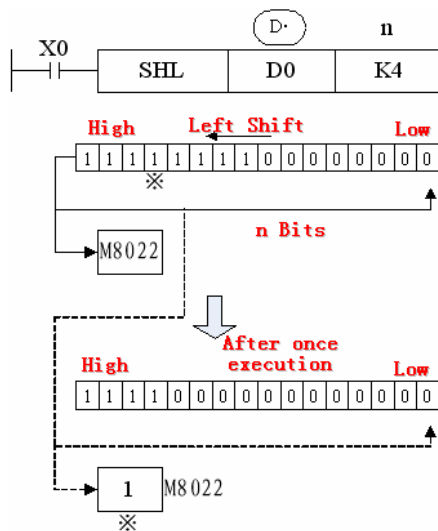

- After once execution, the low bit is filled in 0, the final bit is stored in carry flag.

《Arithmetic shift right》

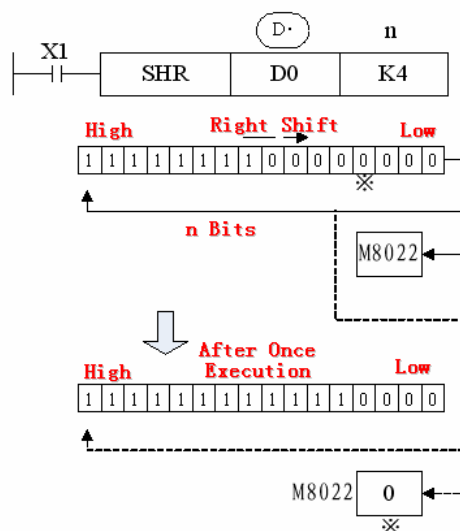

- After once execution, the high bit is same with the bit before shifting, the final bit is stored in carry flag.

Note:

- In the left example, when X1 is ON, left/right shift is executed at every scan cycle.

[LSL] & LSR		Suitable Models:
16 bits instruction:	32 bits instruction: DLSL、DLSR	XC3、XC5

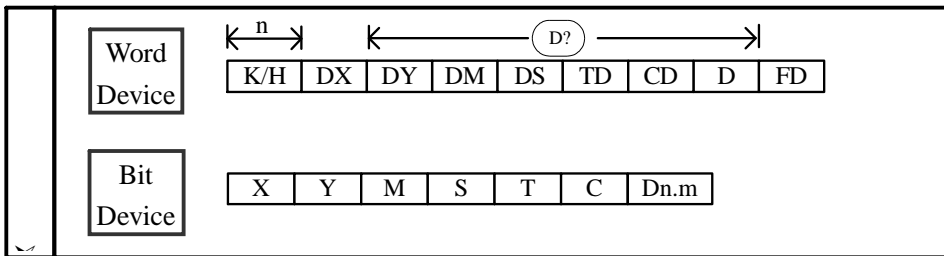

Function & Action

《Logic shift left》

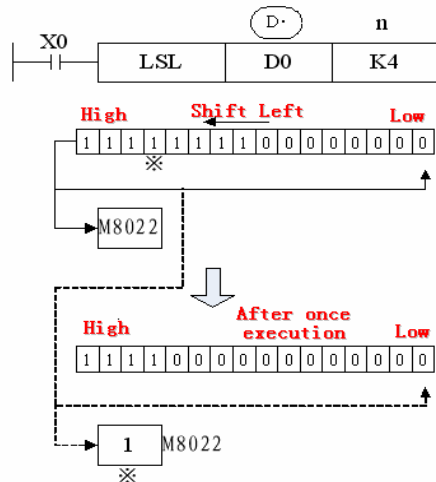

- After once execution, the low bit is filled in 0, the final bit is stored in carry flag.

《Logic shift right》

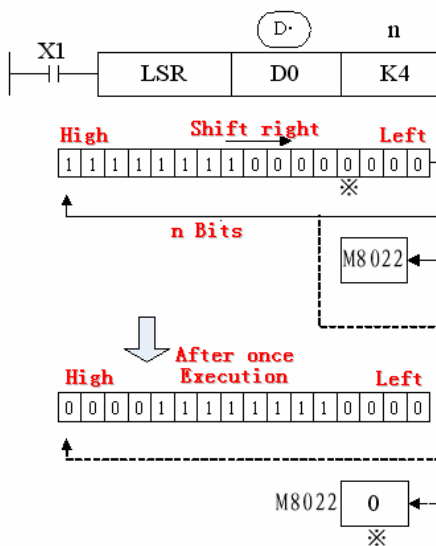

- After once execution, the high bit is same with the bit before shifting, the final bit is stored in carry flag.

NOTE:

- In every scan cycle, loop shift left/right action will be executed

[ROL] & [ROR]		Suitable Models: XC3、XC5
16 bits instruction: ROL、ROR	32 bits instruction: DROL、DROR	

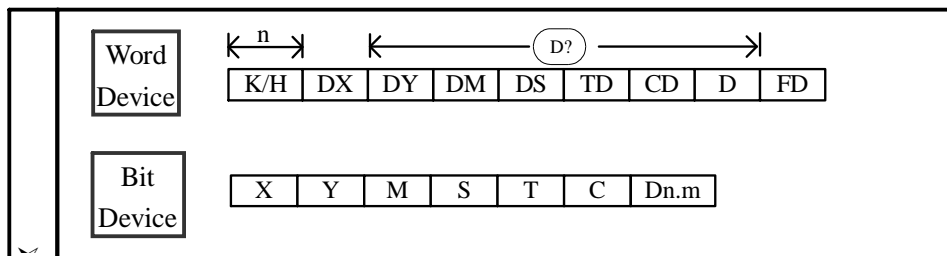

Function & Action

The bit format of the destination device is rotated n bit places to the left on every operation of the instruction

《Rotation shift left》

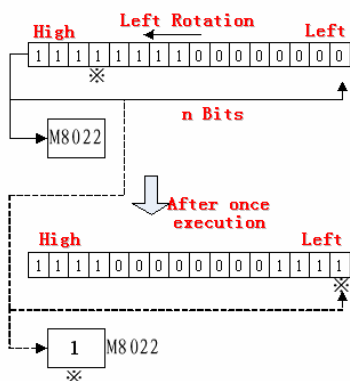
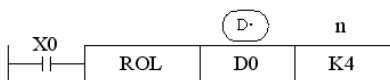

- Every time when X000 turns from OFF to ON, executes n bits left rotation.

《Rotation shift right》

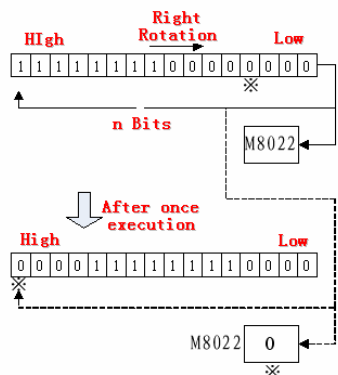
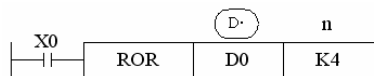

- Every time when X000 turns from OFF to ON, executes n bits right rotation.

[SFTL] & [SFTR]		Suitable Models: XC3、XC5
16 bits instruction: SFTL、SFTR	32 bits instruction: DSFTL、DSFTR	

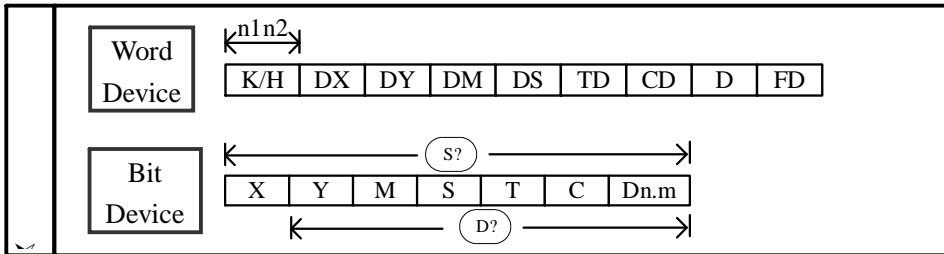

Function & Action

- The instruction copies n2 source devices to a bit stack of length n1. For every new addition of n2 bits, the existing data within the bit stack is shifted n2 bits to the left/right. Any bit data moving to the position exceeding the n1 limit is diverted to an overflow area. The bit shifting operation will occur every time the instruction is processed unless it is modified with either the pulse suffix or a controlled interlock.

《Bit shift left》

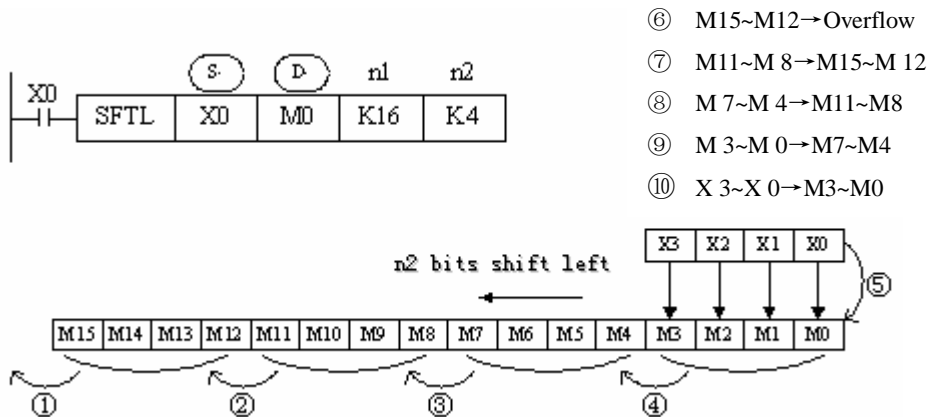

《Bit shift right》

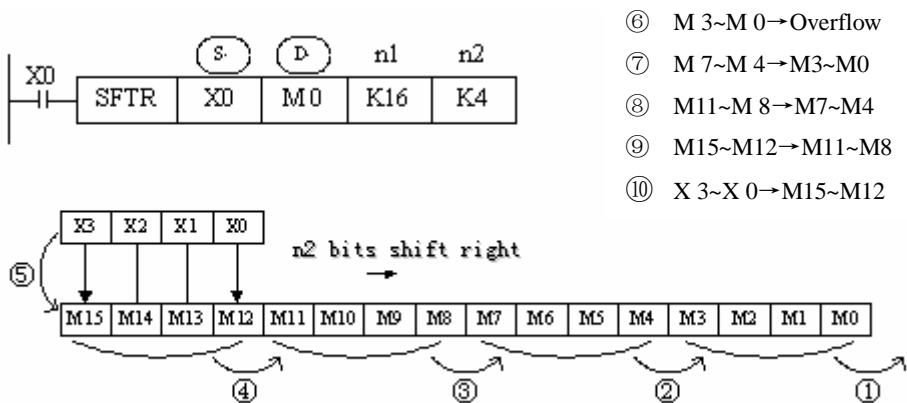

- In every scan cycle, loop shift left/right action will be executed

[WSFL] & [WSFR]		Suitable Models: XC3、XC5
<u>16 bits instruction:</u> WSFL、WSFR	<u>32 bits instruction:</u> DWSFL、DWSFR	

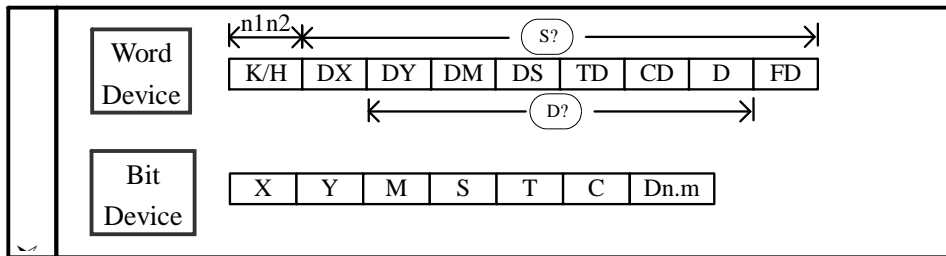

Function & Action

- The instruction copies n2 source devices to a word stack of length n1. For each addition of n2 words, the existing data within the word stack is shifted n2 words to the left/right. Any word data moving to a position exceeding the n1 limit is diverted to an overflow area. The word shifting operation will occur every time the instruction is processed unless it is modified with either the pulse suffix or a controller interlock.

《Word shift left》

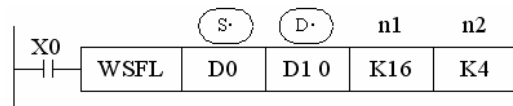

- ⑥ D25~D22→overflow
- ⑦ D21~D18→D25~D22
- ⑧ D17~D14→D21~D18
- ⑨ D13~D10→D17~D14
- ⑩ D3~D0→D13~D10

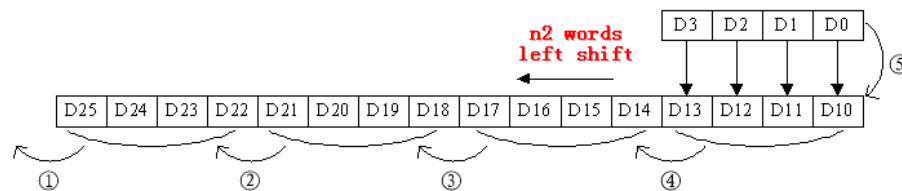

《Word shift right》

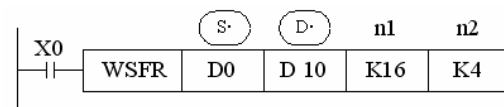

- ⑥ D13~D10→overflow
- ⑦ D17~D14→D13~D10
- ⑧ D21~D18→D17~D14
- ⑨ D25~D22→D21~D18
- ⑩ D3~D0→D25~D22

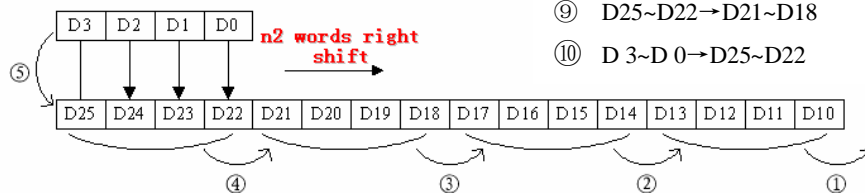

- In every scan cycle, loop shift left/right action will be executed

5-8. Data Convert

Mnemonic	Function
WTD	Single word integer converts to double word integer
FLT	32 bits integer converts to float point
FLTD	64 bits integer converts to float point
INT	Float point converts to integer
BIN	BCD convert to binary
BCD	Binary converts to BCD
ASC	Hex. converts to ASCII
HEX	ASCII converts to Hex.
DECO	Coding
ENCO	High bit coding
ENCOL	Low bit coding

[WTD]		Suitable Models: XC3、XC5
<u>16 bits instruction:</u> WTD	<u>32 bits instruction:</u> -	

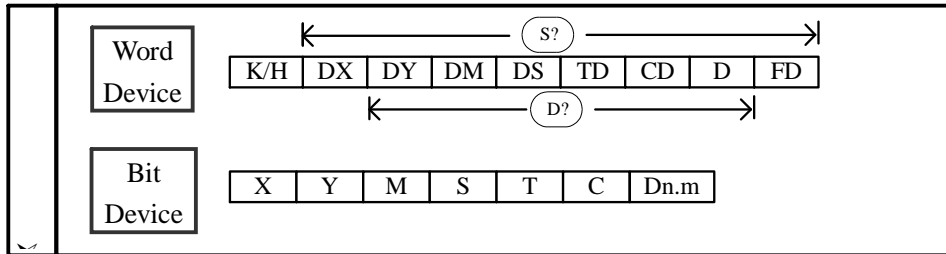

Function & Action

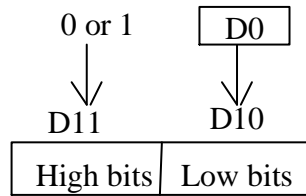
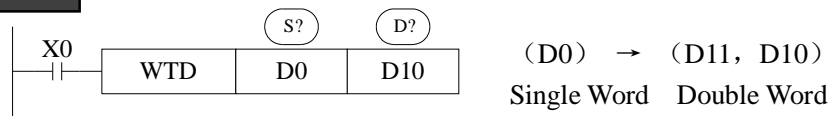

- When single word D0 is positive integer, after executing this instruction, the high bit of double word D10 is 0.
- When single word D0 is negative integer, after executing this instruction, the high bit of double word D10 is 1.

[FLT] & [FLTD]		Suitable Models: XC3、XC5
16 bits instruction: FLT	32 bits instruction: DFLT	

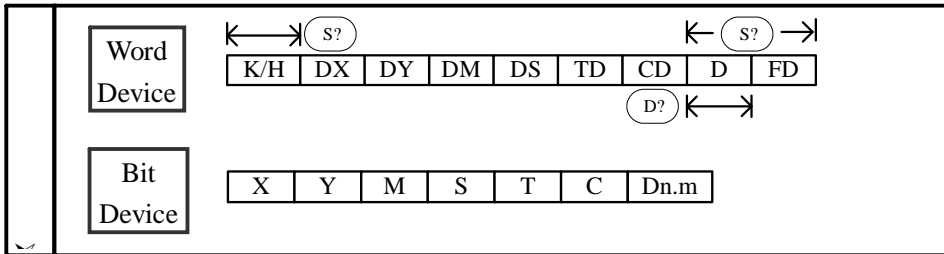

Function & Action

《16 Bits》

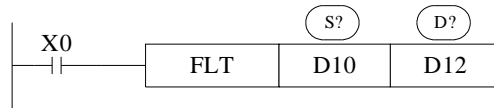

(D10) → (D13,D12)
BIN integer Binary float point

《32 Bits》

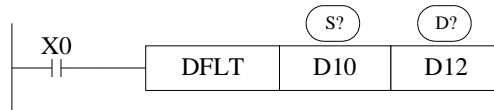

(D11,D10) → (D13,D12)
BIN integer Binary float point

《64 Bits》

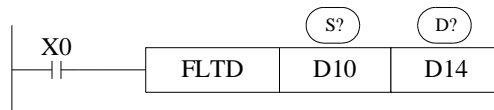

(D13,D12,D11,D10) → (D17,D16,D15,D14)
BIN integer Binary float point

- Convert BIN integer to binary float point. As the constant K、H will auto convert by the float operation instruction, so this FLT instruction can't be used.
- The instruction is contrary to INT instruction.

[INT]		Suitable Models: XC3、XC5
<u>16 bits instruction:</u> -	<u>32 bits instruction:</u> INT	

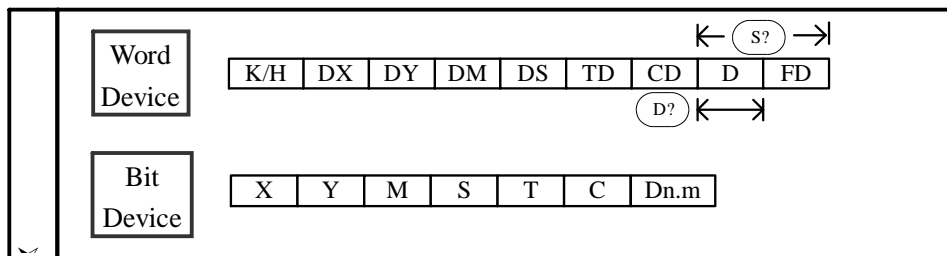

Function & Action

《16 位》

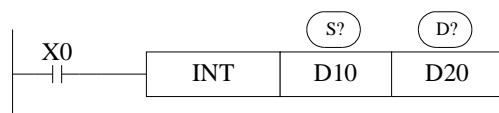

(D11,D10) → (D20)
 Binary Floating BIN integer
 Give up the data after the decimal dot

《32 位》

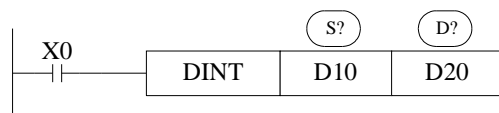

(D11,D10) → (D20,D21)
 Binary Floating BIN integer
 Give up the data after the decimal dot

- The binary source number is converted into an BIN integer and stored at the destination device. Abandon the value behind the decimal point.
- This instruction is contrary to FLT instruction.
- When the result is 0, the flag bit is ON.
 When converting, less than 1 and abandon it, zero flag is ON.
 16 bits operation: -32,768~32,767
 32 bits operation: -2,147,483,648~2,147,483,647

[BIN]		Suitable Models: XC3、XC5
<u>16 bits instruction:</u> BIN	<u>32 bits instruction:</u> -	

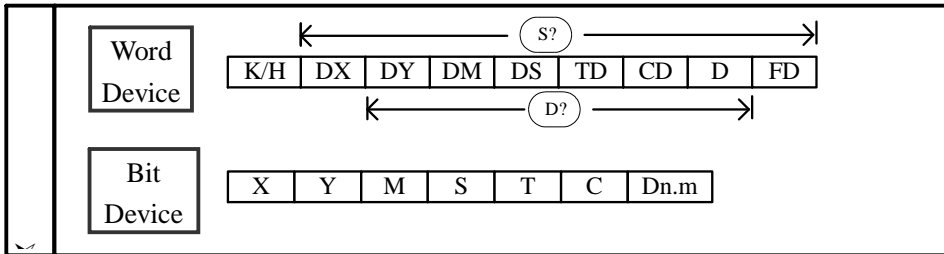

Function & Action

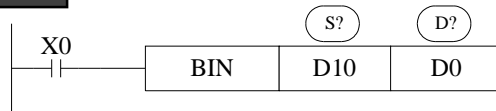

Convert and move instruction of Source (BCD) → destination (BIN)

- When source data is not BCD code, M8067 (Operation error), M8068 (Operation error lock) will not work.
- As constant K automatically converts to binary, so it's not suitable for this instruction.

[BCD]		Suitable Models: XC3、XC5
<u>16 bits instruction:</u> BCD	<u>32 bits instruction:</u> -	

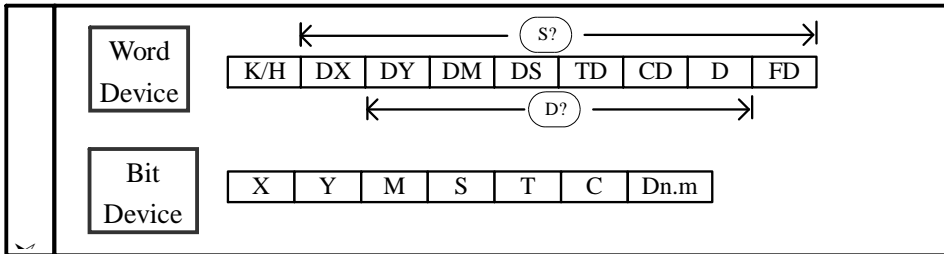

Function & Action

Convert and move instruction of source (BIN)→destination (BCD).

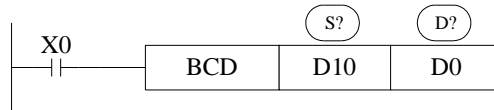

- This instruction can be used to output data directly to a seven-segment display.

[ASCII]		Suitable Models: XC3、XC5
16 bits instruction: ASCII	32 bits instruction: -	

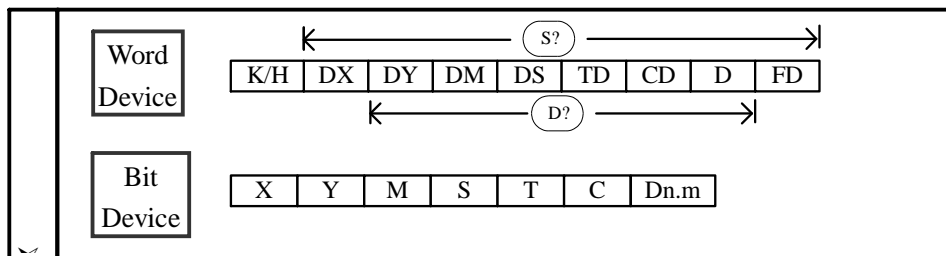

Function & Action

《16 bits convert mode》

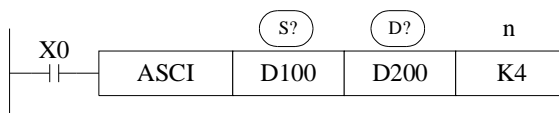

Convert each bit of source's (S) Hex. format data to be ASCII code, move separately to the high 8 bits and low 8 bits of destination (D). The convert alphanumeric number is assigned with n.
(D) is low 8 bits, high 8 bits, store ASCII data.

The convert result is the

Assign start device:	[0]=30H	[1]=31H	[5]=35H
(D100)=0ABCH	[A]=41H	[2]=32H	[6]=36H
(D101)=1234H	[B]=42H	[3]=33H	[7]=37H
(D102)=5678H	[C]=43H	[4]=34H	[8]=38H

D \ n	K1	K2	K3	K4	K5	K6	K7	K8	K9
D200 down	[C]	[B]	[A]	[0]	[4]	[3]	[2]	[1]	[8]
D200 up		[C]	[B]	[A]	[0]	[4]	[3]	[2]	[1]
D201 down			[C]	[B]	[A]	[0]	[4]	[3]	[2]
D201 up				[C]	[B]	[A]	[0]	[4]	[3]
D202 down					[C]	[B]	[A]	[0]	[4]
D202 up						[C]	[B]	[A]	[0]
D203 down							[C]	[B]	[A]
D203 up								[C]	[B]
D204 down									[C]

[HEX]		Suitable Models: XC3、XC5
16 bits instruction: HEX	32 bits instruction: -	

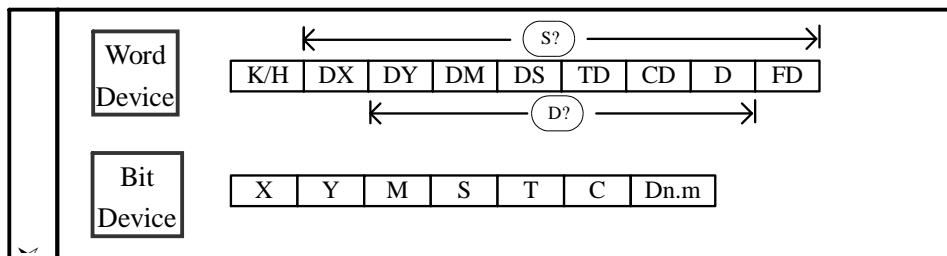

Function & Action

《16 bits switch mode》

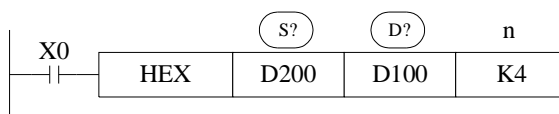

Convert the high and low 8 bits in source to HEX data. Move 4 bits every time to destination. The convert alphanumeric number is assigned by n.

The convert of the upward program is the following:

(S?)	ASCII Code	HEX Convert
D200 down	30H	0
D200 up	41H	A
D201 down	42H	B
D201 up	43H	C
D202 down	31H	1
D202 up	32H	2
D203 down	33H	3
D203 up	34H	4
D204 down	35H	5

(D?)	D102	D101	D100
n			
1	Not change to be 0		? 0H
2			? 0AH
3			? 0ABH
4			0ABCH
5		? 0H	ABC1H
6		? 0AH	BC12H
7		? 0ABH	C123H
8		0ABCH	1234H
9	? 0H	ABC1H	2345H

n=k4

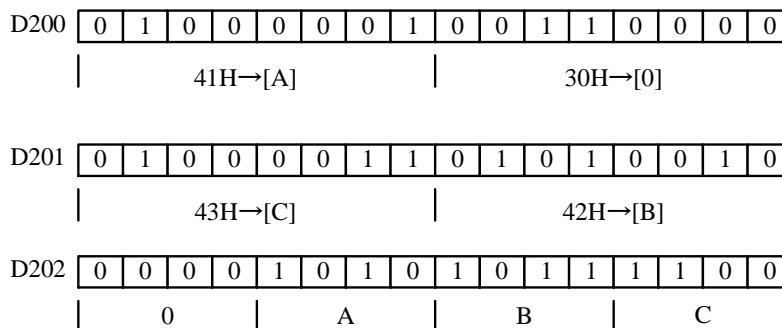

[DECO]		Suitable Models: XC3、XC5
16 bits instruction: DECO	32 bits instruction: -	

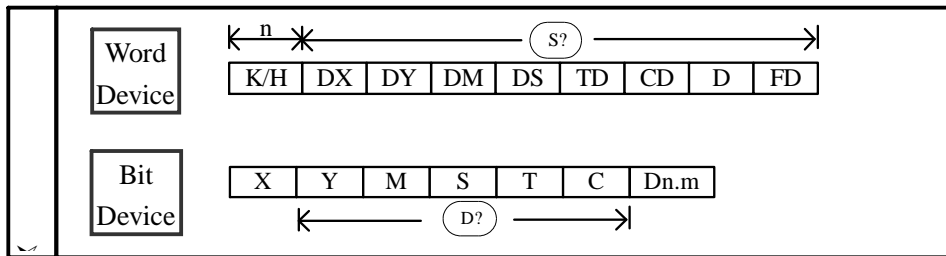

Function & Action

《 When (D?) is software unit》 $n \leq 16$

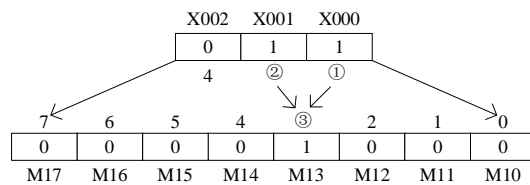
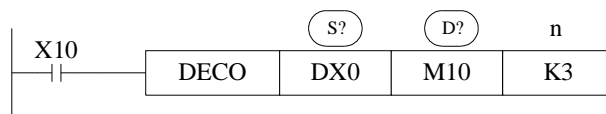

- The source address is $1+2=3$, so starts from M10, the number 3 bit (M13) is 1. If the source are all 0, M10 is 1
- When $n=0$, no operation, beyond $n=0\sim 16$, don't execute the instruction.
- When $n=16$, if coding command "D" is soft unit, it's point is $2^8=256$.
- When drive input is OFF, instructions are not executed, the activate coding output keep on activate.

《 When (D?) is word device》 $n \leq 4$

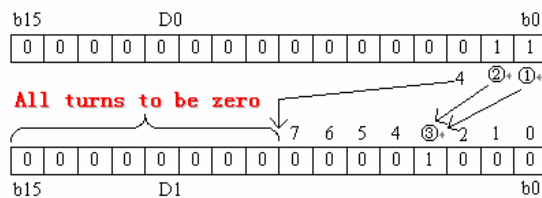
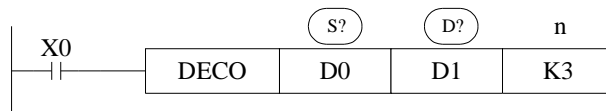

- Source ID's low n bits ($n \leq 4$) are encoded to the destination ID. When $n \leq 3$, destination's high bits all converts to be 0.
- When $n=0$, no disposal, beyond $n=0\sim 4$, don't execute the instruction.

[ENCO]		Suitable Models: XC3、XC5
16 bits instruction: ENCO	32 bits instruction: -	
Word Device		
Bit Device		

Function & Action

《 When (S?) is bit device》 $n \leq 16$

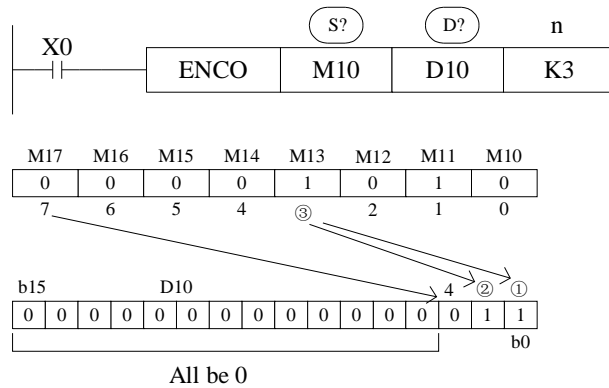

《 When (S?) is word device》 $n \leq 4$

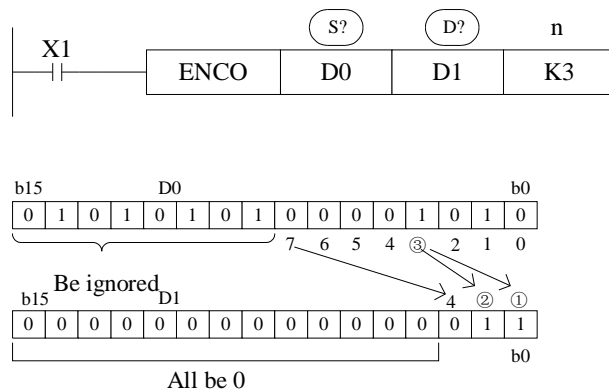

- If many bits in the source ID are 1, ignore the low bits. If source ID are all 0, don't execute the instructions.
- When drive input is OFF, the instruction is not executed, encode output don't change.
- When $n=8$, if encode instruction's "S" is bit unit, it's point number is $2^8=256$

[ENCOL]		Suitable Models: XC3、XC5
<u>16 bits instruction:</u> ENCOL	<u>32 bits instruction:</u> -	

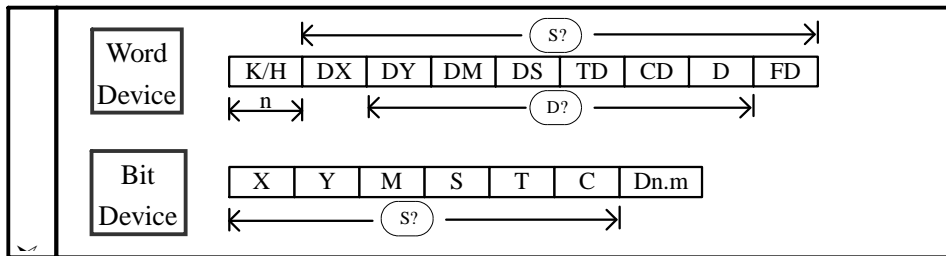

Function & Action

《 If (S?) is bit device》 n ≤ 16

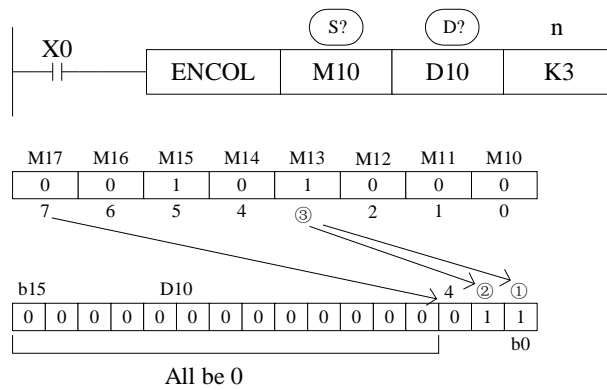

《 (S?) 是字软元件时》 n ≤ 16

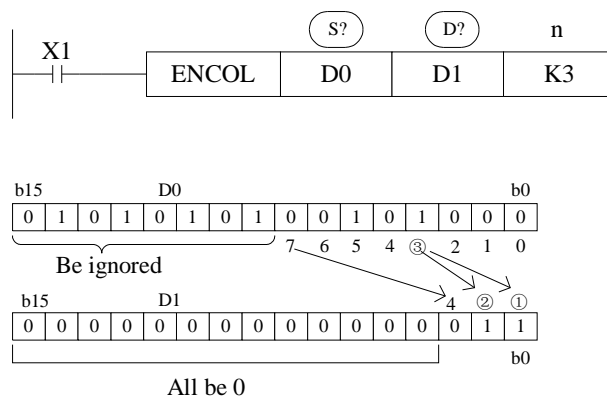

- If many bits in the source ID are 1, ignore the high bits. If source ID are all 0, don't execute the instructions.
- When drive input is OFF, the instruction is not executed, encode output don't change.
- When n=8, if encode instruction's "S" is bit unit, it's point number is 2^8=256

5-9. Floating Operation

Mnemonic	Function
ECMP	Float Compare
EZCP	Float Zone Compare
EADD	Float Add
ESUB	Float Subtract
EMUL	Float Multiplication
EDIV	Float Division
ESQR	Float Square Root
SIN	Sine
COS	Cosine
TAN	Tangent

[ECMP]		Suitable Models: XC3、XC5
<u>16 bits instruction:</u> -	<u>32 bits instruction:</u> ECMP	

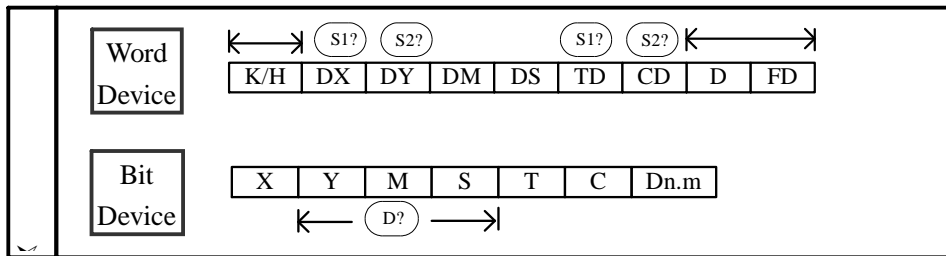

Function & Action

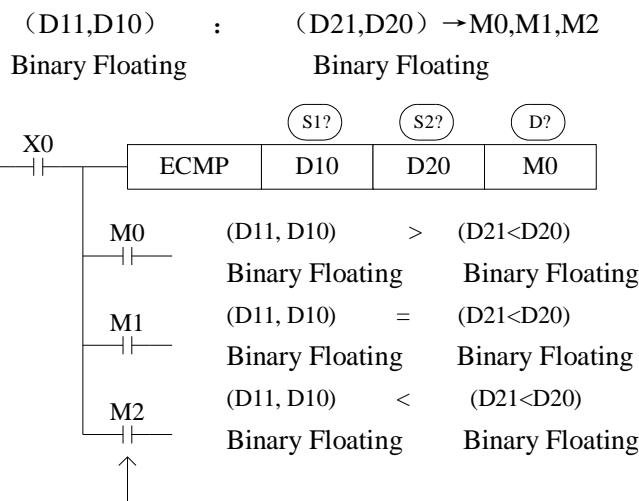

The status of the destination device will be kept even if the ECMP instruction is deactivated.

- The binary float data of S1 is compared to S2. The result is indicated by 3 bit devices specified with the head address entered as D.
- If a constant K or H used as source data, the value is converted to floating point before the addition operation.

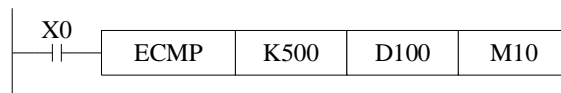

(K500) : (D101, D100) → M10,M11,M12
 Binary converts Binary floating
 to floating

[EZCP]		Suitable Models: XC3、XC5
<u>16 bits instruction:</u> -	<u>32 bits instruction:</u> ECMP	

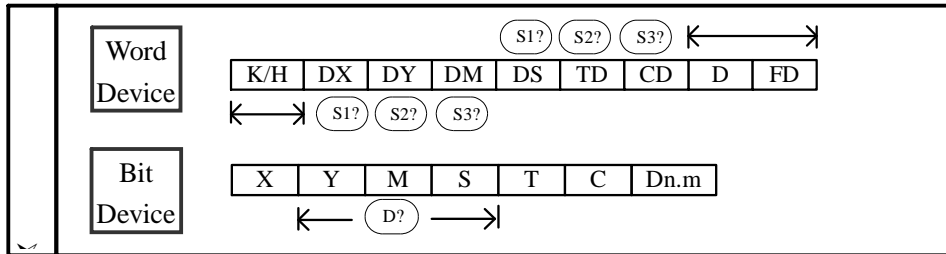

Function & Action

Compare a float range with a float value.

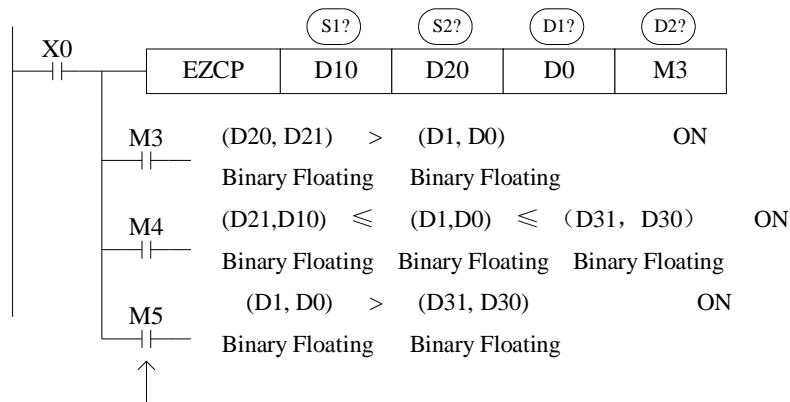

The status of the destination device will be kept even if the EZCP instruction is deactivated.

- The data of S1 is compared to the data of S2. The result is indicated by 3 bit devices specified with the head address entered as D.
- If a constant K or H used as source data, the value is converted to floating point before the addition operation.

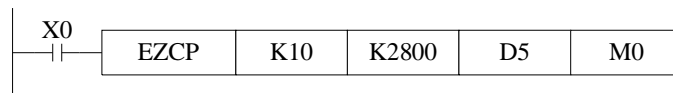

(K10) : [D6,D5] : (K2800) → M0, M1, M2
 Binary converts to Floating Binary Floating Binary converts to Floating

Please set S1<S2, when S2>S1, see S2 as the same with S1 and compare them.

[EADD]		Suitable Models: XC3、XC5
<u>16 bits instruction:</u> -	<u>32 bits instruction:</u> EADD	

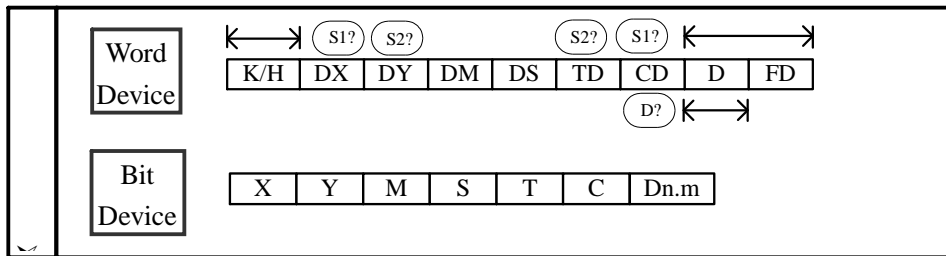

Function & Action

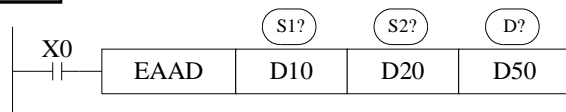

(D11,D10) + (D21,D20) → (D51,D50)
 Binary Floating Binary Floating Binary Floating

- The floating point values stored in the source devices S1 and S2 are algebraically added and the result stored in the destination device D.
- If a constant K or H used as source data, the value is converted to floating point before the addition operation.

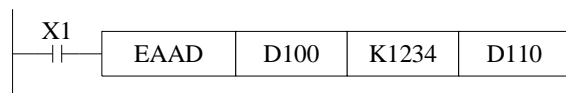

(K1234) + (D101,D100) → (D111,D110)
 Binary converts to Floating Binary Floating Binary Floating

- The same device may be used as a source and as the destination. If this is the case then, on continuous operation of the EADD instruction, the result of the previous operation will be used as a new source value and a new result calculated. This will happen every program scan unless the pulse modifier or an interlock program is used.

[ESUB]		Suitable Models: XC3、XC5
<u>16 bits instruction:</u> -	<u>32 bits instruction:</u> ESUB	

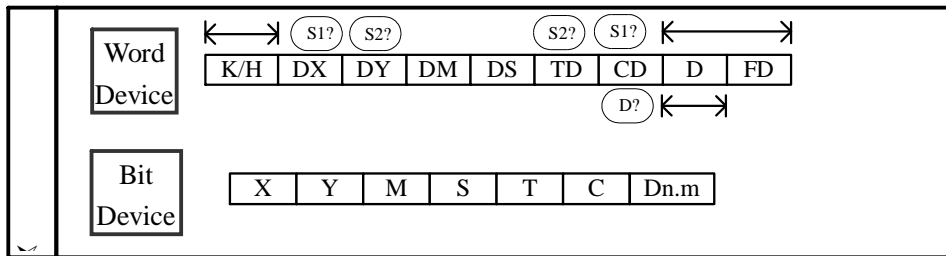

Function & Action

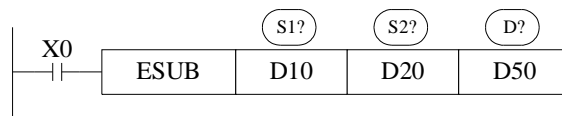

$$(D11,D10) \text{ Binary Floating} - (D21,D20) \text{ Binary Floating} \rightarrow (D51,D50) \text{ Binary Floating}$$

- The floating point value of S2 is subtracted from the floating point value of S1 and the result stored in destination device D.
- If a constant K or H used as source data, the value is converted to floating point before the addition operation.

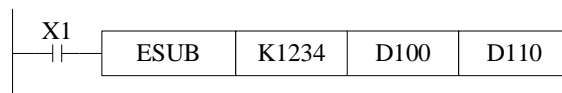

$$(K1234) \text{ Binary converts to Floating} - (D101,D100) \text{ Binary Floating} \rightarrow (D111,D110) \text{ Binary Floating}$$

- The same device may be used as a source and as the destination. If this is the case then, on continuous operation of the EADD instruction, the result of the previous operation will be used as a new source value and a new result calculated. This will happen every program scan unless the pulse modifier or an interlock program is used.

[EMUL]		Suitable Models: XC3、XC5
16 bits instruction: -	32 bits instruction: EMUL	

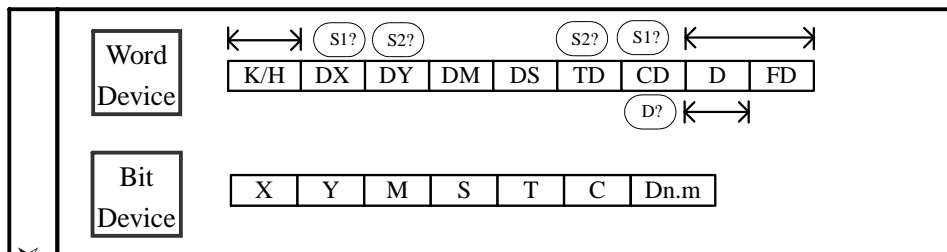

Function & Action

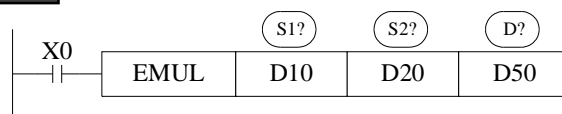

(D11, D10) ? (D21,D20) → (D51,D50)
 Binary Floating Binary Floating Binary Floating

- The floating value of S1 is multiplied with the floating value point value of S2. The result of the multiplication is stored at D as a floating value.
- If a constant K or H used as source data, the value is converted to floating point before the addition operation.

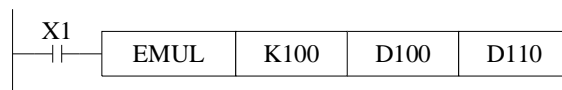

(K100) ? (D101,D100) → (D111,D110)
 Binary converts to Floating Binary Floating Binary Floating

[EDIV]		Suitable Models: XC3、XC5
16 bits instruction: -	32 bits instruction: EDDIV	

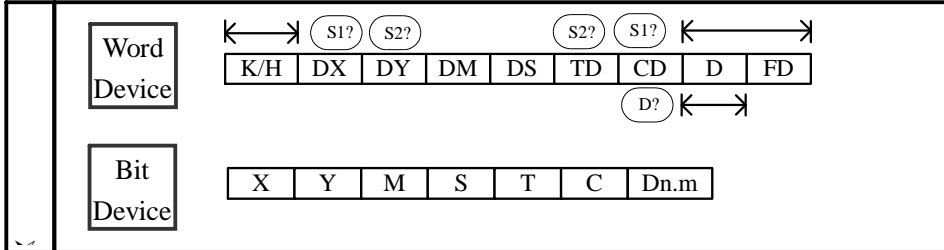

Function & Action

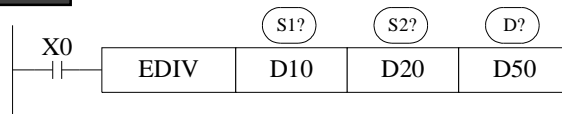

(D11,D10) ? (D21,D20) → (D51,D50)

Binary Floating Binary Floating Binary Floating

- The floating point value of S1 is divided by the floating point value of S2. The result of the division is stored in D as a floating point value. No remainder is calculated.
- If a constant K or H used as source data, the value is converted to floating point before the addition operation.

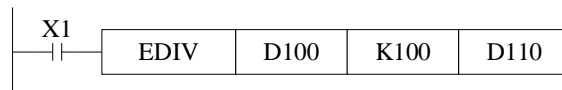

(D101,D100) ? (K100) → (D111,D110)

Binary Floating Binary converts to Floating Binary Floating

- If S2 is zero then a divide by zero error occurs and the operation fails.

[ESQR]		Suitable Models: XC3、XC5
<u>16 bits instruction:</u> -	<u>32 bits instruction:</u> ESQR	

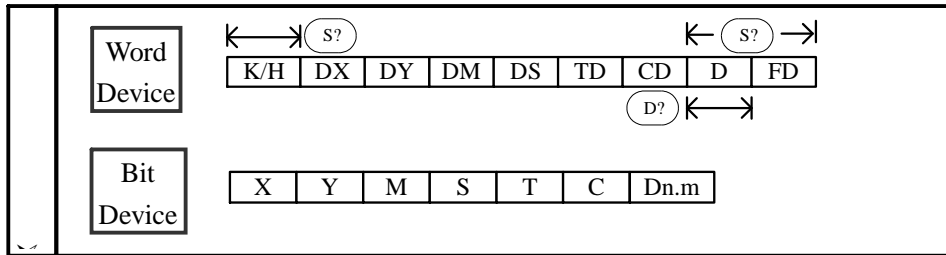

Function & Action

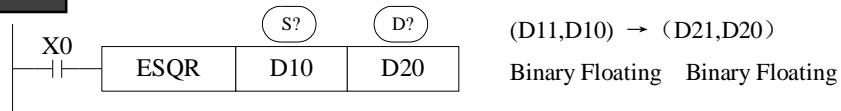

- A square root is performed on the floating point value in S the result is stored in D.
- If a constant K or H used as source data, the value is converted to floating point before the addition operation.

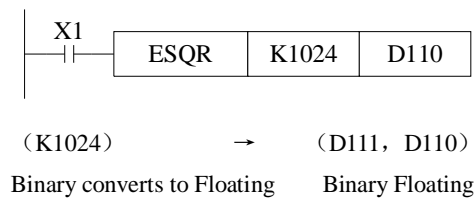

- When the result is zero, zero flag activates
- Only when the source data is positive will the operation be effective. If S is negative then an error occurs and error flag M8067 is set ON, the instruction can't be executed.

[SIN]		Suitable Models: XC3、XC5
<u>16 bits instruction:</u> -	<u>32 bits instruction:</u> SIN	

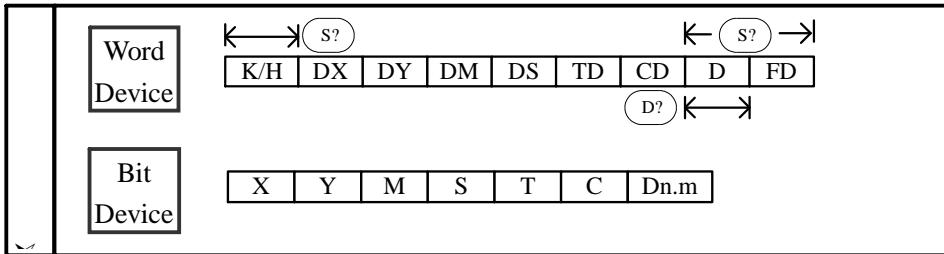

Function & Action

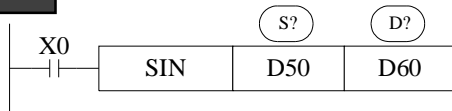

(D51,D50) → (D61,D60)SIN
 Binary Floating Binary Floating

- This instruction performs the mathematical SIN operation on the floating point value in S (angle RAD). The result is stored in D.

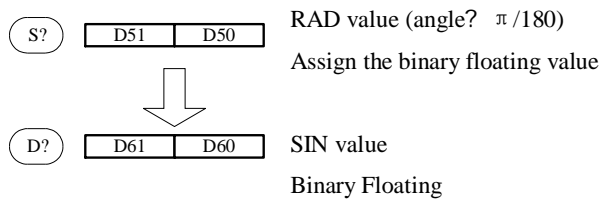

[COS]		Suitable Models: XC3、XC5
<u>16 bits instruction:</u> -	<u>32 bits instruction:</u> COS	

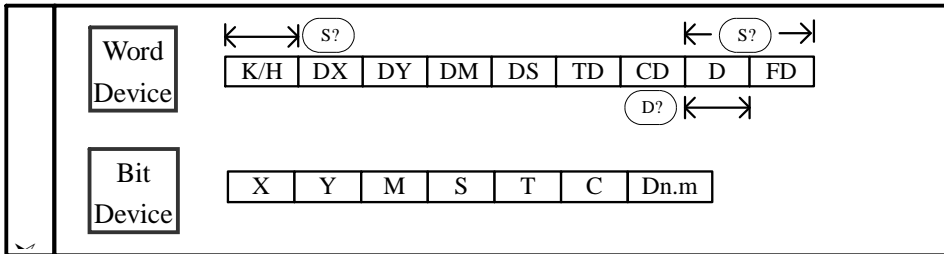

Function & Action

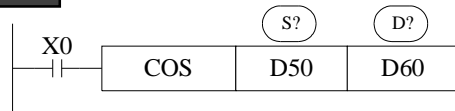

(D51,D50)RAD → (D61,D60)COS
 Binary Floating Binary Floating

- This instruction performs the mathematical COS operation on the floating point value in S (angle RAD). The result is stored in D.

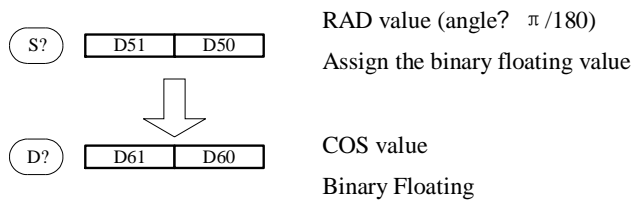

[TAN]		Suitable Models: XC3、XC5
<u>16 bits instruction:</u> -	<u>32 bits instruction:</u> TAN	

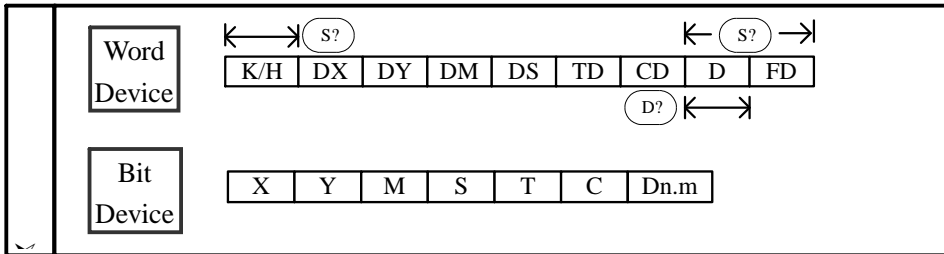

Function & Action

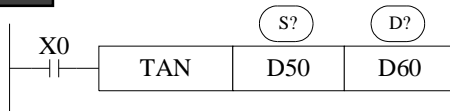

(D51,D50)RAD → (D61,D60)TAN
 Binary Floating Binary Floating

- This instruction performs the mathematical TAN operation on the floating point value in S. The result is stored in D.

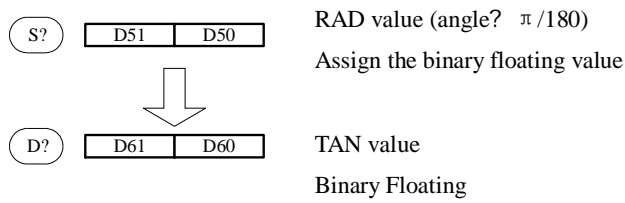

5-10. Clock Operation

Mnemonic	Function
TCMP	Time Compare
TZCP	Time Zone Compare
TADD	Time Add
TSUB	Time Subtract
TRD	Read RTC data
TWR	Set RTC data

Note: The models without clock can not use these instructions.

Time Compare [TCMP]		Suitable Models: XC3、XC5
16 bits instruction: DIV	32 bits instruction: DDIV	

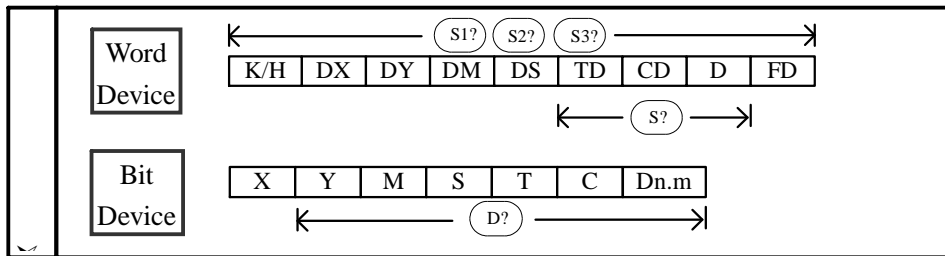

Function & Action

Compare the assigned time with time data.

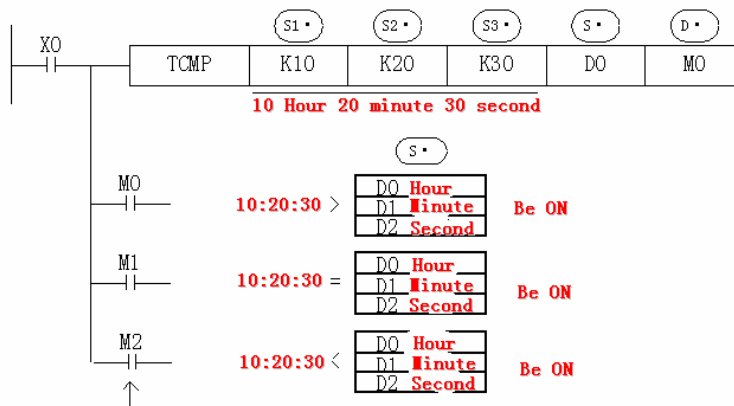

The status of the destination devices is kept, even if the TCMP instruction is deactivated.

- 「 S1? , S2? , S3? 」 represent hours, minutes and seconds respectively. This time is compared to the time value in the 3 data devices specified by the head address S?, The result is indicated in the 3 bit devices specified by the head address D?

- S1?: Assign the compare standard “Hour”
- S2?: Assign the compare standard “Minute”
- S3?: Assign the compare standard “Second”

- S? : Assign the “Hour” of clock data
- S? +1 : Assign the “Minute” of clock data
- S? +2 : Assign the “Second” of clock data

D?, D? +1, D? +2 : According to the compare result, the 3 devices output ON/OFF.

- The valid range of “Hour” is 「0~23」 .
- The valid range of “Minute” is 「0~59」 .
- The valid range of “Second” is 「0~59」 .

[TZCP]		Suitable Models: XC3、XC5
16 bits instruction: DIV	32 bits instruction: DDIV	

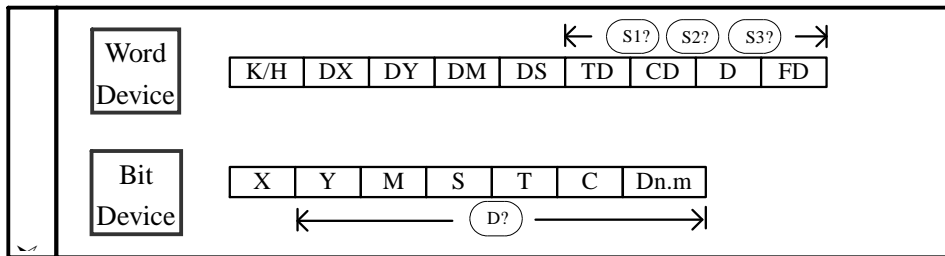

Function & Action

Compare the two assigned time with time data

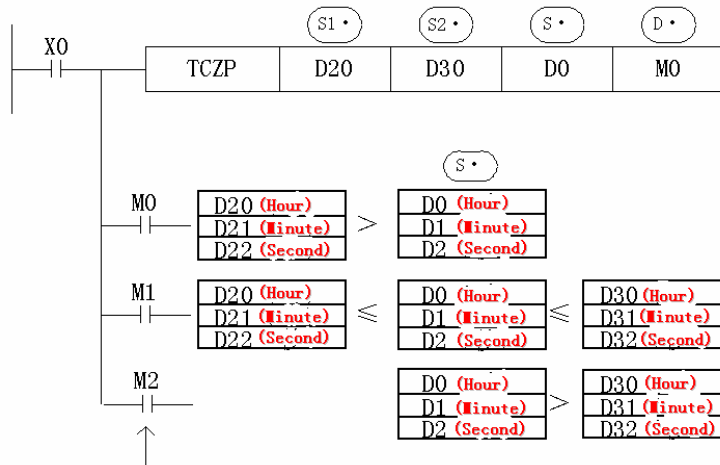

The status of the destination devices is kept, even if the TCMP instruction is deactivated.

- Compare the 3 clock data start from (S?) with the two ends on the clock compare bound, according to the area bound, output the three ON/OFF status starts from (D?)

- (S1?), (S1?) + 1, (S1?) + 2 : Assign the compare low limit in the form of “Hour”, “Minute” and “Second”.
- (S2?), (S2?) + 1, (S2?) + 2 : Assign the compare low limit in the form of “Hour”, “Minute” and “Second”.
- (S?), (S?) + 1, (S?) + 2 : Assign the clock data in the form of “Hour”, “Minute” and “Second”.
- (D?), (D?) + 1, (D?) + 2 : According to the compare result, the 3 devices output ON/OFF.

The valid range of “Hour” is 「0~23」 .
 The valid range of “Minute” is 「0~59」 .
 The valid range of “Second” is 「0~59」 .

[TADD]		Suitable Models: XC3、XC5
<u>16 bits instruction:</u> DIV	<u>32 bits instruction:</u> DDIV	

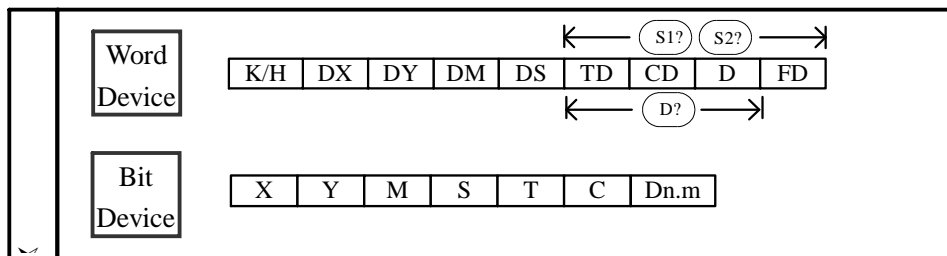

Function & Action

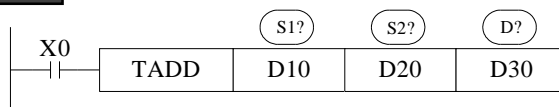

$$(D10, D11, D12) + (D20, D21, D22) \rightarrow (D30, D31, D32)$$

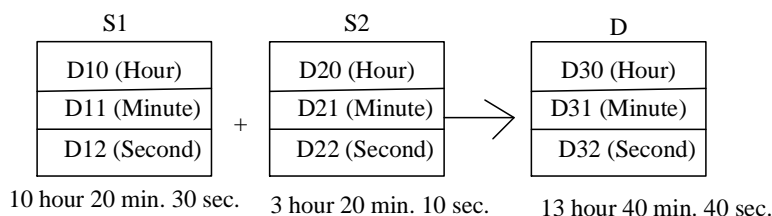

- Each of S1, S2 and D specify the head address of 3 data devices to be used a time value. The time value in S1 is added to the value in S2, the result is stored to D as a new time value.
- If the addition of the two times results in a value greater than 24 hours, the value of the result is the time remaining above 24 hours. When this happens the carry flag M8022 is

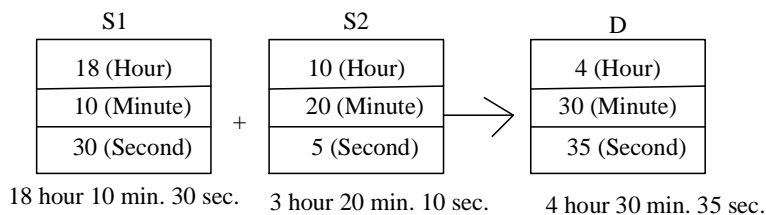

- When the result is 0 (0 Hour 0 Minute 0 Second), Set zero flag ON.

The valid range of “Hour” is 「0~23」 .
 The valid range of “Minute” is 「0~59」 .
 The valid range of “Second” is 「0~59」 .

[TSUB]		Suitable Models: XC3、XC5
16 bits instruction: DIV	32 bits instruction: DDIV	

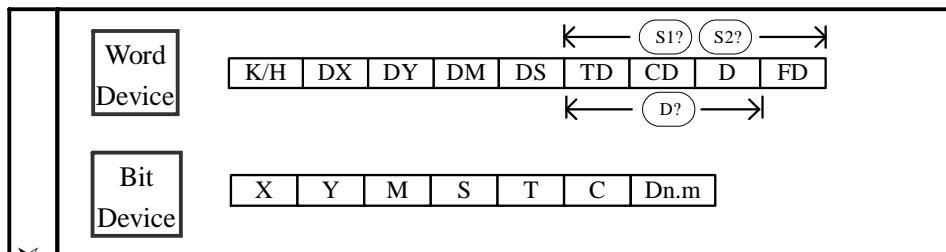

Function & Action

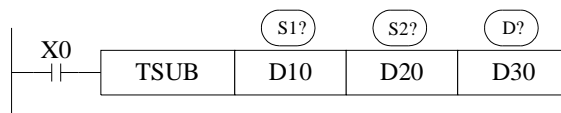

(D10, D11, D12) – (D20, D21, D22) → (D30, D31, D32)

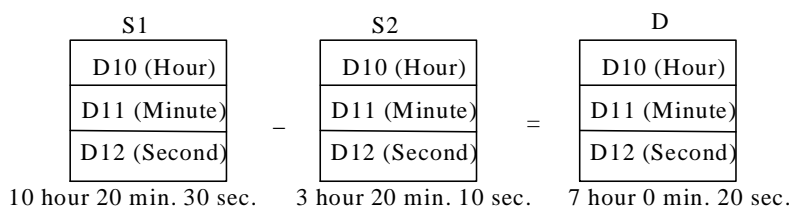

- Each of S1, S2 and D specify the head address of 3 data devices to be used a time value. The time value in S1 is subtracted from the time value in S2, the result is stored to D as a new time.
- If the subtraction of the two times results in a value less than 00:00:00 hours, the value of the result is the time remaining below 00:00:00 hours. When this happens the borrow flag M8021 is set ON.

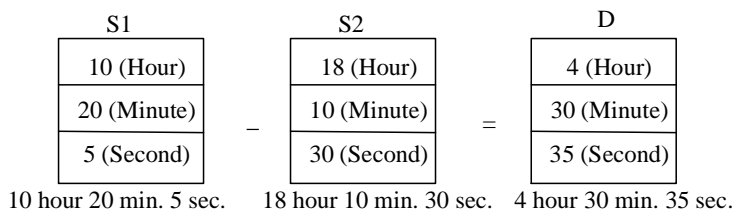

- When the result is 0 (0 hour 0 min. 0 sec.), zero flag set ON.

The valid range of “Hour” is 「0~23」 .
 The valid range of “Minute” is 「0~59」 .
 The valid range of “Second” is 「0~59」 .

[TRD]		Suitable Models: XC3、XC5
16 bits instruction: DIV	32 bits instruction: DDIV	

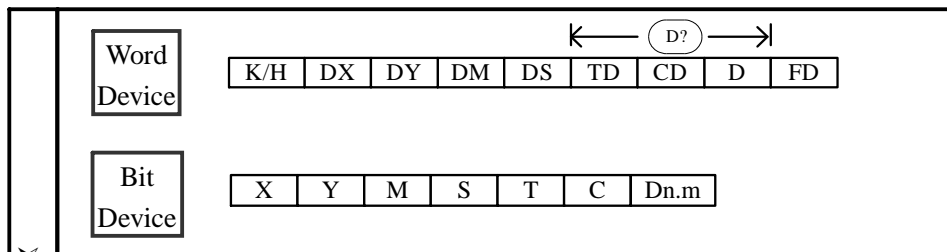

Function & Action

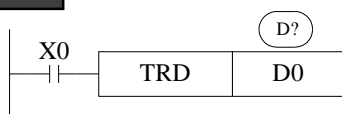

The current time and date of the real time clock are read and stored in the 7 data devices specified by the head address D.

- Read PLC's real time clock according to the following format.
The reading source is the special data register (D8013~D8019) which save clock data.

		Unit	Item	Clock data		Unit	Item
Special data register for real time clock	D8018	Year		0-99	→	D0	Year
	D8017	Month		1-12	→	D1	Month
	D8016	Date		1-31	→	D2	Date
	D8015	Hour		0-23	→	D3	Hour
	D8014	Minute		0-59	→	D4	Minute
	D8013	Second		0-59	→	D5	Second
	D8019	Week		0 (Sun.)-6 (Sat.)	→	D	Week

[TWR]		Suitable Models: XC3、XC5
16 bits instruction: DIV	32 bits instruction: DDIV	

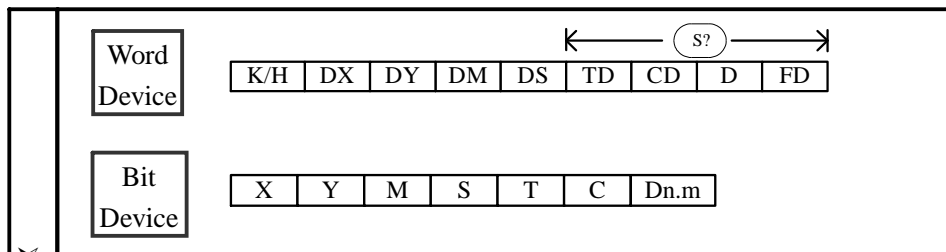

Function & Action

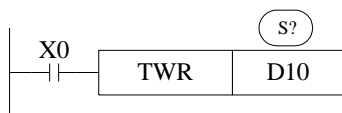

The 7 data devices specified with the

- Write the set clock data into PLC's real time clock.
In order to write real time clock, the 7 data devices with the head address (S?) should be pre-set.

	Unit	Item	Clock data		Unit	Item	
Data for clock setting	D0	Year	0-99	→	D8018	Year	Special data register for real time clock t
	D1	Month	1-12	→	D8017	Month	
	D2	Date	1-31	→	D8016	Date	
	D3	Hour	0-23	→	D8015	Hour	
	D4	Minute	0-59	→	D8014	Minute	
	D5	Second	0-59	→	D8013	Second	
	D6	Week	0 (Sun.)-6 (Sat.)	→	D8019	Week	

After executing TWR instruction, the time in real time clock will immediately change to be the new set time. So, when setting the time it is a good idea to set the source data to a time a number of minutes ahead and then drive the instruction when the real time reaches this value.

6. Special Function Instructions (XC3/XC5)

In this chapter, we introduce the functions of high-speed count input, high-speed pulse output and MODBUS communication instructions of XC series PLC.

6-1. High-speed Count

6-2. Pulse Uoutput

6-3. Modbus Instructions

6-4. Free Format Communication

6-5. PWM Pulse Modulate

6-6. Frequency Testing

6-7. Precise Time

6-8. Interrupt Function

6-9. CANBUS Communication (XC5 Series)

6-1. High-speed Count

● High-speed Count Function

XC series PLC all have high speed count function. By choosing different counter, you can realize count function of increment mode, pulse + direction input mode, AB phase mode count, the frequency can reach 200KHz.

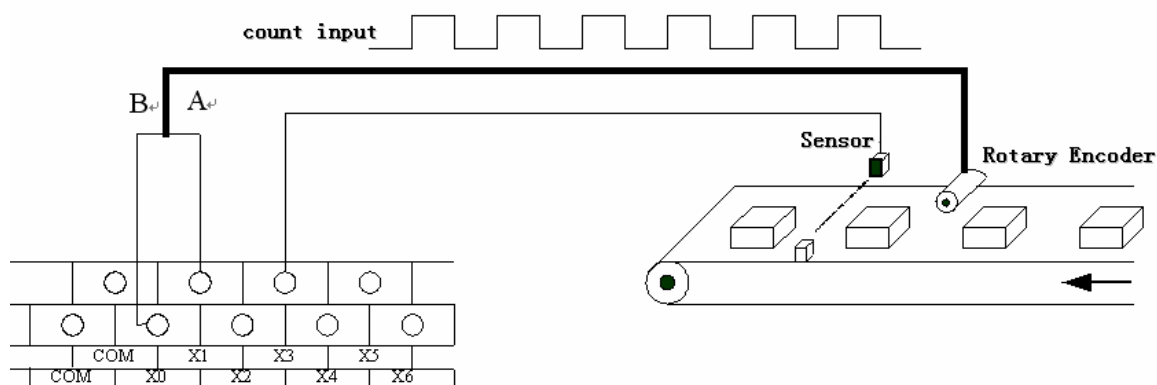

● The Assignment of Count Input Ports

1、 In the following table, we list how many high speed counters are there in XC series PLC:

PLC Model		High-speed counters		
		Increment Mode	Pulse+ Direction Mode	AB Phase Mode
XC3 Series	XC3-14	4	2	2
	XC3-24/XC3-32	5	3	3
	XC3-48/XC3-60	4	2	2
XC5 Series	XC5-32	2	1	1
	XC5-48/XC5-60	5	3	3

2、About the definition of high speed counter's input terminals, please refer to the following table:

When X input terminals are not used as high speed input port, they could be used as common input terminals.

[U]---count pulse input [Dir]---count direction judgment (OFF means +, ON means -)

[A]---A phase input [B]---B phase input

XC3-48、XC3-60 PLC models

	Increment Mode										Pulse+ Direction Input Mode					AB Phase Mode		
	C600	C602	C604	C606	C608	C610	C612	C614	C616	C618	C620	C622	C624	C626	C628	C630	C632	C634
X000	U										U					B		
X001											Dir					A		
X002		U										U					B	
X003												Dir					A	
X004			U															
X005				U														

XC3-24、XC3-32 AND XC5-48、XC5-60 PLC MODELS

	Increment Mode										Pulse+ Direction Input Mode					AB Phase Mode		
	C600	C602	C604	C606	C608	C610	C612	C614	C616	C618	C620	C622	C624	C626	C628	C630	C632	C634
X000	U										U					B		
X001											Dir					A		
X002																		
X003			U									U					B	
X004												Dir					A	
X005																		
X006				U									U					B
X007													Dir					A
X010																		
X011					U													
X012						U												

XC3-14 PLC MODELS

	Increment Mode										Pulse+ Direction Input Mode					AB Phase Mode		
	C600	C602	C604	C606	C608	C610	C612	C614	C616	C618	C620	C622	C624	C626	C628	C630	C632	C634
X000	U										U					B		
X001											Dir					A		
X002		U																
X003			U															
X004													U				B	
X005				U									Dir				A	

XC5-32 PLC MODELS

	Increment Mode										Pulse+ Direction Input Mode					AB Phase Mode		
	C600	C602	C604	C606	C608	C610	C612	C614	C616	C618	C620	C622	C624	C626	C628	C630	C632	C634
X000	U										U					B		
X001											Dir					A		
X002																		

3、About the high speed counters which don't support four times frequency in AB phase high speed counters, please refer to the following table:

PLC MODELS		High speed counters without four times counter
XC3 Series	XC3-14	C630
	XC3-24/ XC3-32	C632
	XC3-48/ XC3-60	C630
XC5 Series	XC5-32	-
	XC5-48/ XC5-60	C632

● **Input Mode of High Speed Counter's Signal**

1、**Input Mode**

Increment Mode:

Under increment mode, input pulse signal, the count value increases with each pulse signal.

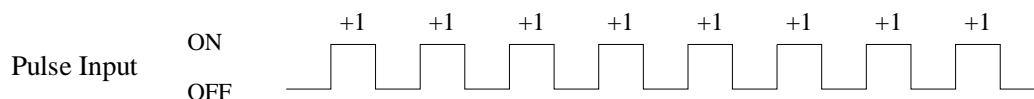

Pulse + Direction input mode:

Under pulse + direction input mode, both the pulse signal and direction signal are input, the count value increase/decrease according to the direction signal's status.

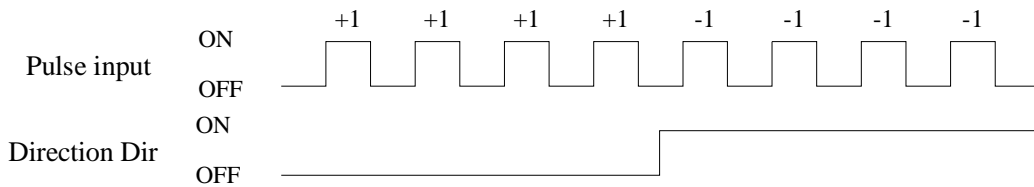

AB phase mode:

Under AB phase mode, the count value increase/decrease according to the signal difference (A phase and B phase)

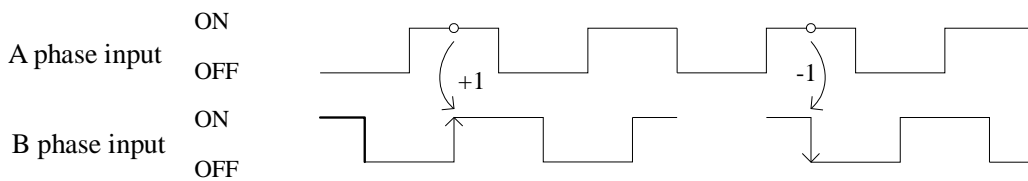

2、Count Value

High speed counter's count bound: K-2,147,483,648 ~ K+2,147,483,647. If the count value exceeds the bound, overflow or underflow will occur; if occur overflow, K+2,147,483,647 will change to be K-2,147,483,648, then go on counting; if occur underflow, K-2,147,483,648 will change to be K+2,147,483,647, then go on counting

3、Reset

High speed counter's count format is software reset format

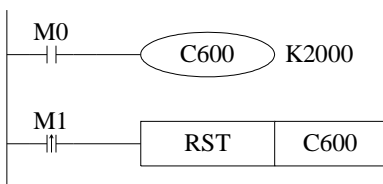

See the right graph, when M0 is ON, C600 starts to count with the pulse input from X0 port; when M1 turns from OFF to ON, the status value and count value of C600 reset.

● **Connection of input terminal**

The following, we take C600 as the example to introduce the connection format.

AB phase mode

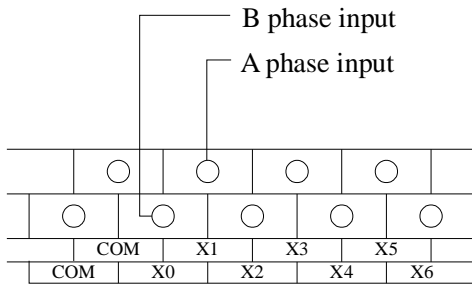

Pulse + Direction mode

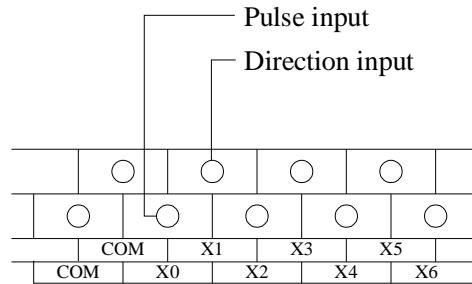

Increment Mode

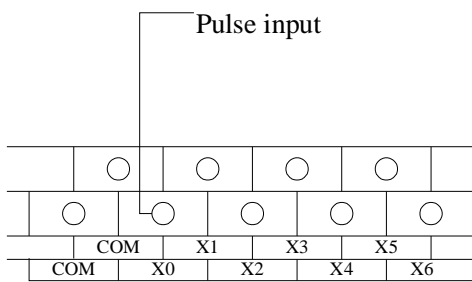

● **Program Example**

The following, we take XC3-60 PLC model as the example to tell how to program with the high speed count:

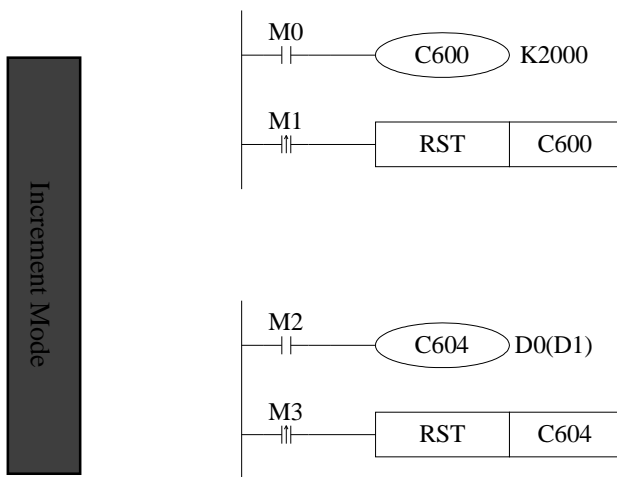

- When M0 is ON, C600 counts with the OFF→ON from X000.
- When M1 activates, reset when execute RST instruction.
- When M2 is ON, C604 starts to count. The count input is X004, In this example, the set value is the content indirectly assigned in the data register.
- See the graph, reset via M3 in the sequential control program.

Pulse + Direction input mode

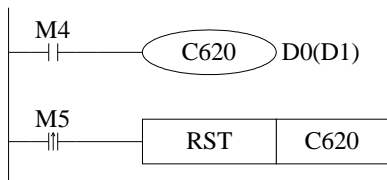

- When M4 is ON, C620 counts with OFF → ON from X000, via OFF or ON status from X001, decide the count direction. If X001 is OFF, execute increase count; if X001 is ON, execute decrease count”.

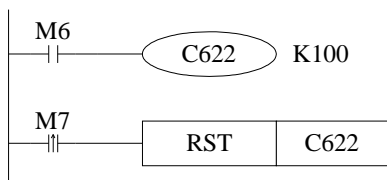

- When M6 is ON, C622 counts with OFF → ON from X000, via OFF or ON status from X002, decide the count direction. If X003 is OFF, execute increase count; if X003 is ON, execute decrease count”.

AB phase mode

AB phase counter realize increase/decrease count by the judgment of A、 B phase. The output contactor’s (correspond with the current value) action is the same with the preceding single phase counter.

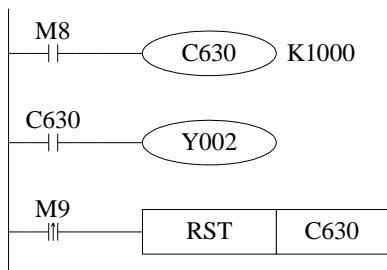

- When M8 is ON, C630 counts with the input X000 (B phase), X001(A phase) via interruption.
- If M9 is ON, execute RST instruction to reset.
- If the current value exceeds the set value, then Y002 is ON; If the current value is smaller than the set value, then Y002 is OFF

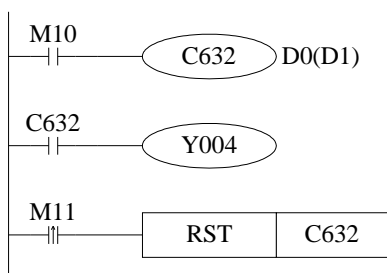

- When M10 is ON, C632 starts to count. The count input is X002 (B phase)、 X003(A phase).
- Reset via M11.
- If the current value exceeds the set value, then Y004 activates; If the current value is smaller than the set value, then Y004 is OFF

- In the condition of A phase input is OFF → ON, if B phase input is OFF, the counter is increase count; if B phase input is ON, the counter is decrease count.

Times Frequency

High speed counters have one time frequency and four times frequency two modes. PLC's defaulted count mode is four times frequency mode. The count format of two count modes is shown below:

One time frequency mode:

- A、B phase counter's count format:

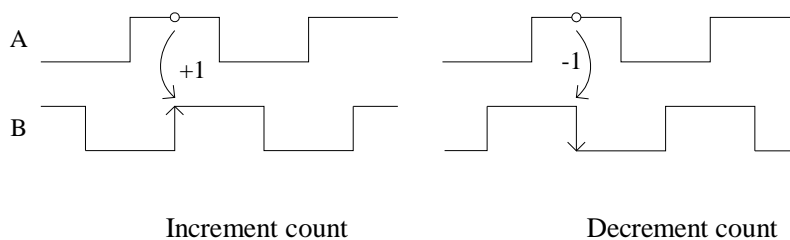

Four times frequency mode

- AB phase count add 4 times frequency count mode. The count mode is shown below:

➤ Increment count:

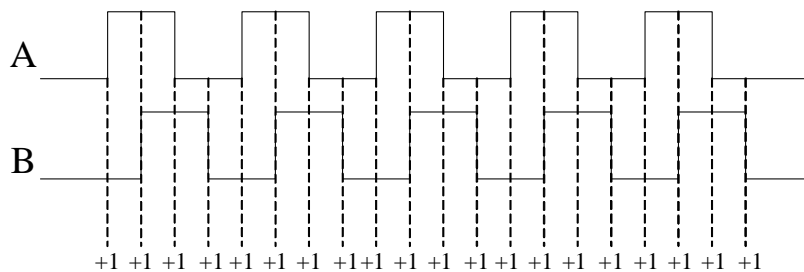

➤ Decrement count:

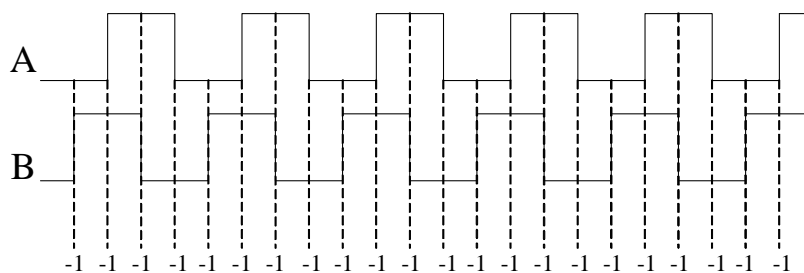

- In the condition of testing the same pulses by the counter, the count value equals four times under four times frequency mode of that under one time frequency mode.

The setting method of 4 times frequency mode:

FD8241	Times of C630 frequency	1 is 1 time frequency, 4 is 4 times frequency,
FD8242	Times of C632 frequency	1 is 1 time frequency, 4 is 4 times frequency
FD8243	Times of C634 frequency	1 is 1 time frequency, 4 is 4 times frequency

6-2. Pulse Output

● Pulse Output Function

Normally XC3 series and XC5 series PLC have 2 channels pulse output. Via different instruction to program, you can realize single direction pulse output without speedup/speed-down; or you can realize single direction pulse output with speedup/speed-down; or you can realize multiply-segment, positive/negative output and so on. The output frequency can reach 400K Hz.

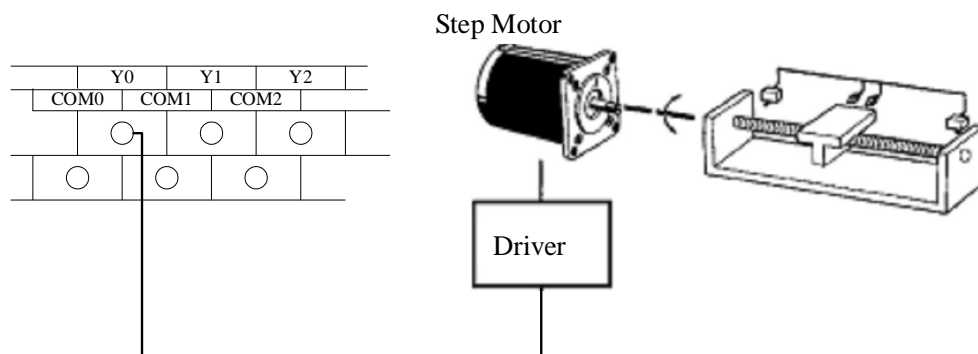

Note: 1) To use pulse output, you should use PLC with transistor output. Such as XC3-14T-E or XC3-60RT-E etc.

2) XC5-32 PLC models have 4 channels (Y0、Y1、Y2、Y3) pulse output function.

● Type and application of pulse output

1、Single direction pulse output without speedup/speed-down

- Frequency: 0~400KHz
- Output terminals: Y0 or Y1
- Output mode: sequential or limited pulse output
- Pulse number: 16 bits instructions 0~K32767
32 bits instructions 0~K2147483647
- Instructions: PLSY、PLSF
PLSY: generate certain quantity pulse with the assigned frequency
PLSF: generate sequential pulse with changeable frequency form

> PLSY Instruction:

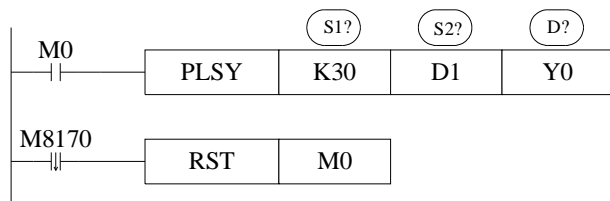

- Generate certain quantity pulse with the assigned frequency; support 32 bits instruction [DPLSY].
 - Ⓢ1? Assign the Frequency. Operands: K、TD、CD、D、FD
 - Ⓢ2? Assign the generated pulse volume. Operands: K、TD、CD、D、FD
 - ⓈD? Assign Y port which generates pulse, can only output at Y000 or Y001
- When M0 is ON, PLSY instruction output pulse of 30Hz at Y0, the pulse number is assigned by D1, when sending pulse, coil M8170 sets ON. When the output pulse reach the set value, stop pulse output, coil M8170 sets OFF, reset M0.

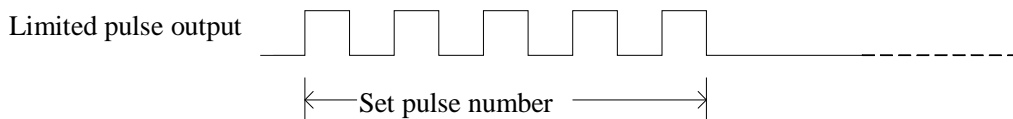

After finish outputting the set pulse number, output will auto stop.

> PLSF Instruction:

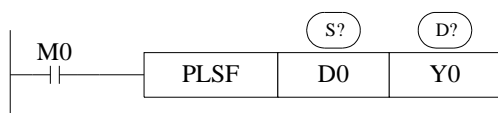

- Generate sequential pulse with changeable frequency form
- Support 32 bits instruction [DPLSF].
- Ⓢ? Assign the frequency. Operands: K、TD、CD、D、FD
Bound: 200~400KHz (If the set frequency is lower than 200Hz, output 200Hz)
- ⓈD? Assign Y port which generates pulse, can only output at Y000 or Y001
- With the changing of the set frequency in D0, the output pulse frequency from Y0 changes.
- Accumulate pulse number in register D8170

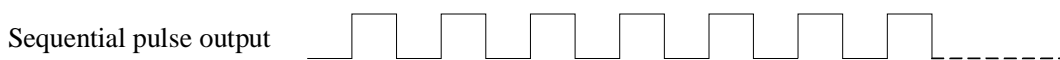

Continuously output pulse with the set frequency till pass the statement, then stop outputting.

2、 One-direction pulse output with speedup/speed-down

- Frequency: 0~400KHz
- Speedup/speed-down time: Below 5000ms
- Output terminals: Y0 or Y1
- Output Mode: Limited pulse
- Pulse number: 16 bits instruction 0~K32767
32 bits instruction 0~K2147483647
- Instruction: PLSR
PLSR: generate certain pulse with the assigned frequency and speedup/speed-down time.

➤ Pulse output of single segment and single direction

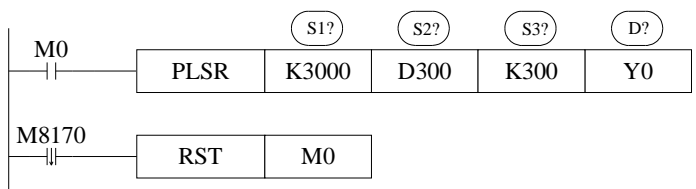

- Generate a certain quantity pulse with the assigned frequency; support 32 bits instruction [DPLSR]。

- ① S1? Highest frequency. Operands: K、TD、CD、D、FD
- ② S2? Total output pulse number. Operands: K、TD、CD、D、FD
- ③ S3? Speedup/speed-down time. Operands: K、TD、CD、D、FD
- ④ D? Assign Y number of output pulse, could only be output at Y000 or Y001

- When M0 is ON, PLSR starts pulse output, send assigned pulse number according to the assigned speedup/speed-down slope、highest frequency. To output with the constant speed, set the speedup/speed-down time as 0. If set the pulse number as H 7FFFFFFF, infinity pulse number will be sold out, at this time coil M8170 set ON.
- When the output pulse number reaches the set value, stop pulse outputting, at this time coil M8170 set OFF, reset M000. See the following chart

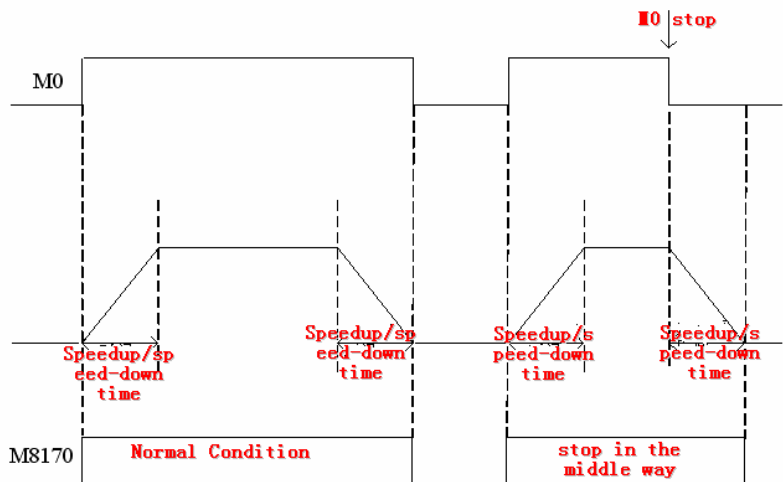

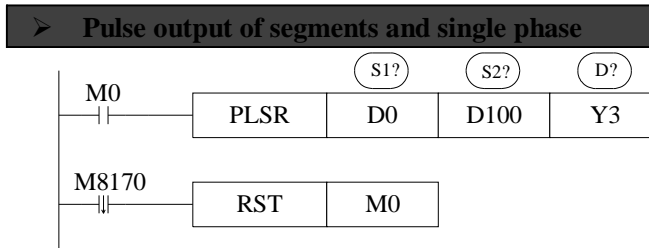

- The instruction which generates a certain quantity pulse with the assigned frequency.
 - ① S1? An area with Dn or FDn as the start address. In the above example, D0 set the highest frequency of segment 1 pulse, D1 set the highest frequency of segment 1 pulse, D2 set the highest frequency of segment 2 pulse, D3 set the highest frequency of segment 2 pulse, if the set value of Dn, Dn+1 are both 0, it means segment finish. You can set at most 24 segments. Operands: D, FD
 - ② S2? Speedup/speed-down time. Here the time means the speed time from start to the first segment's speedup time, meantime, all segments' frequency and time slope are defined. So the following speedup/speed-down speed follows them. Operands: K, TD, CD, D, FD
 - ③ D? Assign the Y number of output pulse, can only output at Y000 or Y001
- Support double words output DPLSR, here D0、 D1 set the highest frequency of segment 1、 D2、 D3 set the pulse number of segment 1, D4、 D5 set the highest frequency of segment 2、 D6、 D7 set the pulse number of segment 2.....

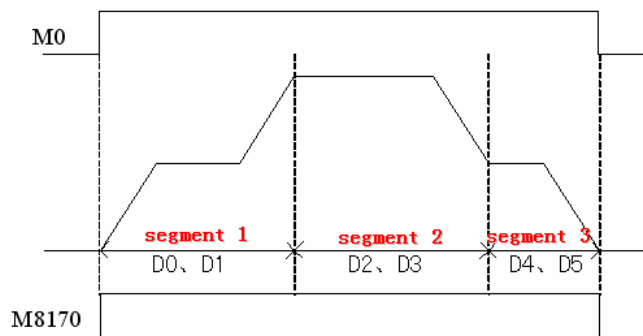

3、Dual Pulse Output with speedup/speed-down

- Frequency: 0~400KHz
- Speedup/speed-down time: Below 5000ms
- Output Terminals: Y0 or Y1
- Direction output terminal: Any Y
- Output Mode: Limited number of pulse
- Pulse Number: 16 bits instruction: 0~K32767
32 bits instruction: 0~K2147483647

- Instruction: PLSR

PLSR: Generate certain pulse with the assigned frequency and speedup/speed-down time.

➤ Dual Pulse Output with Speedup/Speed-down

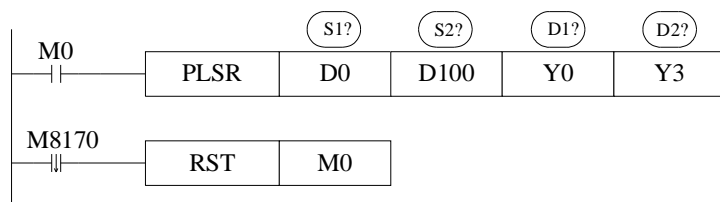

- Generate certain pulse with the assigned frequency, speedup/speed-down time, pulse direction.

- (S1?) An area which takes Dn or FDn with the start address. In the preceding example, D0 set the max frequency of segment 1, D1 set pulse number of segment 1. D2 set the max frequency of segment 2, D3 set pulse number of segment 2, if Dn、Dn+1 are both 0, it means segment finish. You can set 24 segments at most. Operands: D, FD.
- (S2?) Speedup/speed-down time, here the time means the speedup time from the start to the highest frequency. At the same time all segments' frequency and time slope is defined, so the following speedup/speed-down format all do according to them. Operands: K、TD、CD、D、FD
- (D1?) Assign Y number of output pulse, can only output at Y000 or Y001
- (D2?) Assign Y number of output pulse direction, can be assigned at your will. E.g. In (S1?) , if the pulse number is a positive value in segment 1, Y output ON; if be negative, Y is OFF. Please note: in once segment pulse output, pulse's direction is only determined by the pulse number set value (positive or negative) of the first segment.

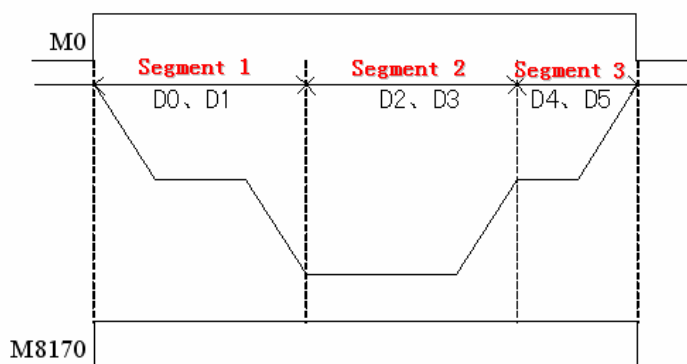

4、Pulse Segment Switch [PLSNEXT]

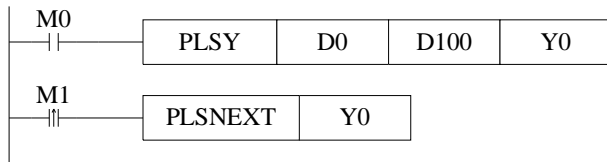

- In the condition of pulse output reaches the highest frequency of current segment, and stably output, if M1 turns from OFF to ON, then enter next pulse output with the speedup/speed-down time.
- In pulse output speedup/speed-down process, execute this instruction is invalid.

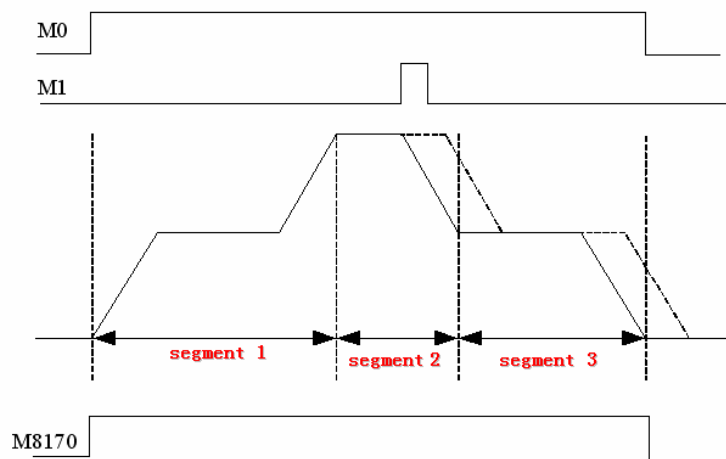

----- (the broken line) means the original pulse output curve

5、Pulse Stop [STOP]

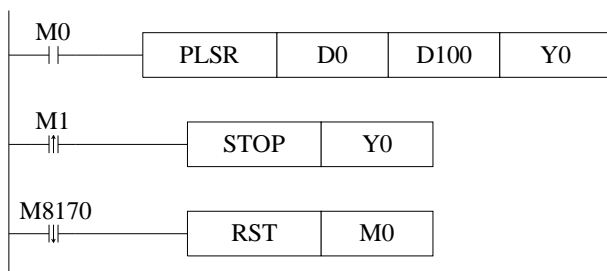

- If M000 turns from OFF to ON, PLSY activates and Y000 output pulse, D0 assign the frequency, D001 assign the pulse number, D100 assign the speedup/speed-down time, when the output pulse number reaches the set value, stop pulse outputting. At the rising edge of M001, STOP instruction stop pulse outputting at Y000 immediately.

● **Application**

E.g.1: Fixed Stop

With subsection pulse output statement [PLSR] and pulse segment switch statement [PLSNEXT], realize fixed-length function.

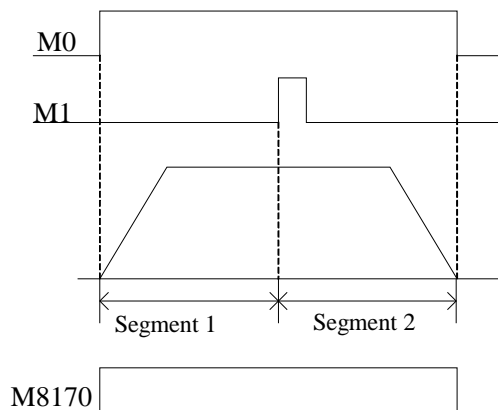

Take the preceding program as the example, in D0, D1 and D2, D3, set two parts pulse output with the same frequency value. The pulse number in D3 is set to be the number needed When M1 is ON. This will realize fixed-length stop function. Refer to the right graph:

E.g.2: Follow Relationship

The pulse output frequency of Y0 equals the tested input frequency of X003. If the tested input frequency at X003 changes, the output frequency at Y0 changes relatively.

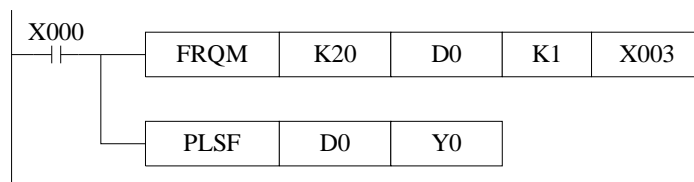

● **Pulse output special coil and register**

Some flag bits of pulse output is shown below:

ID	High frequency pulse ID	Function	Description
M8170	PULSE_1	Sending pulse flag	Be 1 at pulse sending
M8171		32 bits pulse sending overflow flag	Be 1 when overflow
M8172		Direction flag	1 is positive direction, the correspond direction port is ON
M8173	PULSE_2	Sending pulse flag	Be 1 at pulse sending
M8174		32 bits pulse sending overflow flag	Be 1 when overflow
M8175		Direction flag	1 is positive direction, the correspond direction port is ON
M8176	PULSE_3	Sending pulse flag	Be 1 at pulse sending
M8177		32 bits pulse sending overflow flag	Be 1 when overflow
M8178		Direction flag	1 is positive direction, the correspond direction port is ON
M8179	PULSE_4	Sending pulse flag	Be 1 at pulse sending
M8180		32 bits pulse sending overflow flag	Be 1 when overflow
M8181		Direction flag	1 is positive direction, the correspond direction port is ON

Some special registers of pulse output:

ID	High frequency pulse ID	Function	Description
D8170	PULSE_1	The low 16 bits of accumulated pulse number	
D8171		The high 16 bits of accumulated pulse number	
D8172		The current segment (means No.n segment)	
D8173	PULSE_2	The low 16 bits of accumulated pulse number	
D8174		The high 16 bits of accumulated pulse number	
D8175		The current segment (means No.n segment)	
D8176	PULSE_3	The low 16 bits of accumulated pulse number	
D8177		The high 16 bits of accumulated pulse number	
D8178		The current segment (means No.n segment)	
D8179	PULSE_4	The low 16 bits of accumulated pulse number	
D8180		The high 16 bits of accumulated pulse number	
D8181		The current segment (means No.n segment)	
D8190	PULSE_1	The low 16 bits of accumulated pulse number	
D8191		The high 16 bits of accumulated pulse number	
D8192	PULSE_2	The low 16 bits of accumulated pulse number	
D8193		The high 16 bits of accumulated pulse number	
D8194	PULSE_3	The low 16 bits of accumulated pulse number	
D8195		The high 16 bits of accumulated pulse number	
D8196	PULSE_4	The low 16 bits of accumulated pulse number	

6-3. Communication Function

XC3-PLC、XC5-PLC main units can fulfill your requirement of communication and network. They not only support simple network (Modbus protocol、free communication protocol), but also support those complicate network. XC3-PLC、XC5-PLC offer communication access, with which you can communicate with the devices (such as printer, instruments etc.) that have their own communication protocol.

XC3-PLC、XC5-PLC all support Modbus protocol、free protocol these communication function, XC5-PLC also have CANbus function.

COM Port

There are 2 COM ports (Port1、Port2) on XC3 series PLC main units, while there are 3 COM ports on XC5 series PLC main units. Besides the same COM ports (Port1、Port2), they have also CAN COM port.

COM 1 (Port1) is the program port, it can be used to download the program and connect with the other devices. The parameters (baud rate, data bit etc.) of this COM port are fixed, can't be re-set.

COM 2 (Port2) is communication port, it can be used to download program and connect with the other devices. The parameters (baud rate, data bit etc.) of this COM port can be re-set via software.

Via BD board, XC series PLC can expend another COM port. This COM port could be RS232 and RS485.

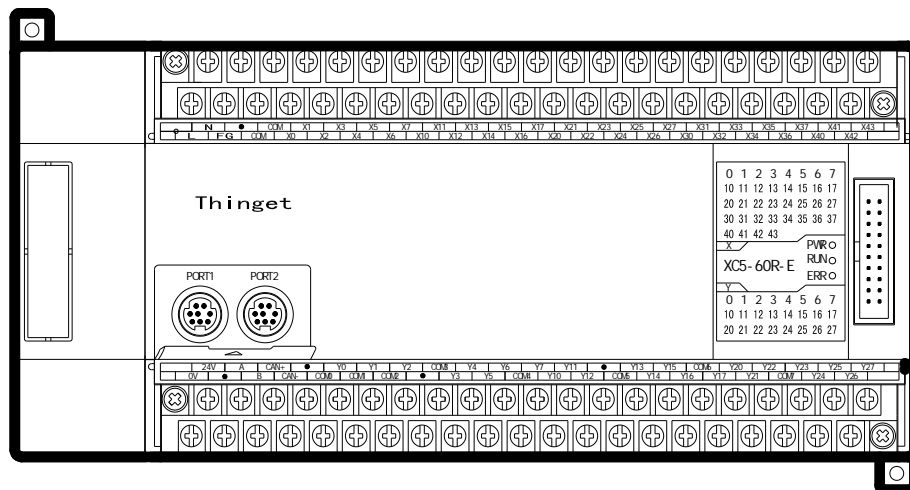

1、RS232 COM port

● **The pin graph of COM 1 (Port1):**

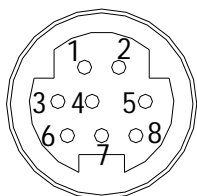

- 2: PRG
- 4: RxD
- 5: TxD
- 6: VCC
- 8: GND

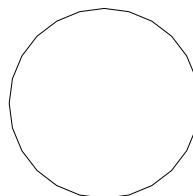

2、

Mini Din 8 core socket (Hole)

About RS485 COM port, A is “+” signal、 B is “-“ signal.

On XC series PLC, COM2 (Port2) can be both RS485 and RS232, so, you can't only use two at the same time.

● **The pin graph of COM 1 (Port1):**

3、

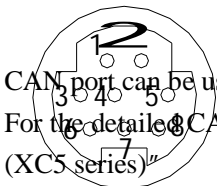

- 4: RxD
- 5: TxD
- 8: GND

CAN port can be used to realize CANbus communication.

For the details of CAN communication function, please refer to “ 6-8. CAN bus function (XC5 series)”

Mini Din 8 core socket (Hole)

Communication Parameter

Station	Modbus Station number: 1~254、255 (FF) is free format communication
Baud Rate	300bps~115.2Kbps
Data Bit	8 bits data bit、 7 bits data bit
Stop Bit	2 stop bits、 1 stop bit
Check	Even、 Odd、 No check

The defaulted parameters of COM 1:

Station number is 1、 baud rate is 19200bps、 8 data bit、 1 stop bit、 Even check

Parameter Setting

XC series PLC can set the communication parameters with the COM port

How to set the communication parameter:

	Number	Function	Description
COM 1	FD8210	Communication mode	255 is free format, 1~254 bit is modbus station number
	FD8211	Communication format	Baud rate, data bit, stop bit, check
	FD8212	ASC timeout judgment time	Unit: ms, if set to be 0, it means no timeout waiting
	FD8213	Reply timeout judgment time	Unit: ms, if set to be 0, it means no timeout waiting
	FD8214	Start symbol	High 8 bits invalid
	FD8215	End symbol	High 8 bits invalid
	FD8216	Free format setting	8/16 bits cushion, with/without start bit, with/without stop bit
COM 2	FD8220	Communication mode	255 is free format, 1~254 bit is modbus station number
	FD8221	Communication format	Baud rate, data bit, stop bit, check
	FD8222	ASC timeout judgment time	Unit: ms, if set to be 0, it means no timeout waiting
	FD8223	Reply timeout judgment time	Unit: ms, if set to be 0, it means no timeout waiting
	FD8224	Start symbol	High 8 bits invalid
	FD8225	End symbol	High 8 bits invalid
	FD8226	Free format setting	8/16 bits cushion, with/without start bit, with/without stop bit

Setting method of communication parameters:

FD8211 (COM1) /FD8221 (COM2):

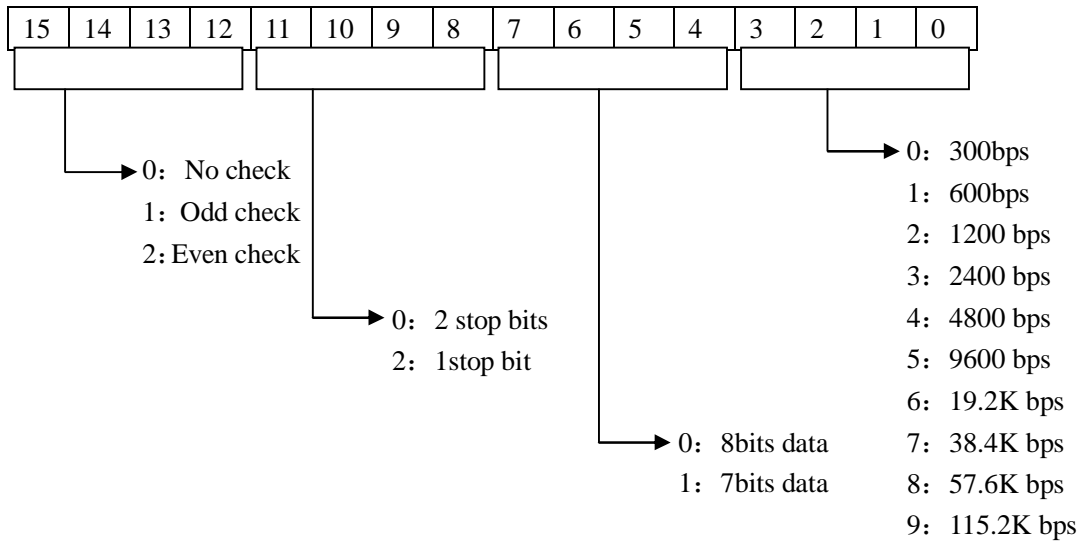

FD8216 (COM1) /FD8226 (COM2):

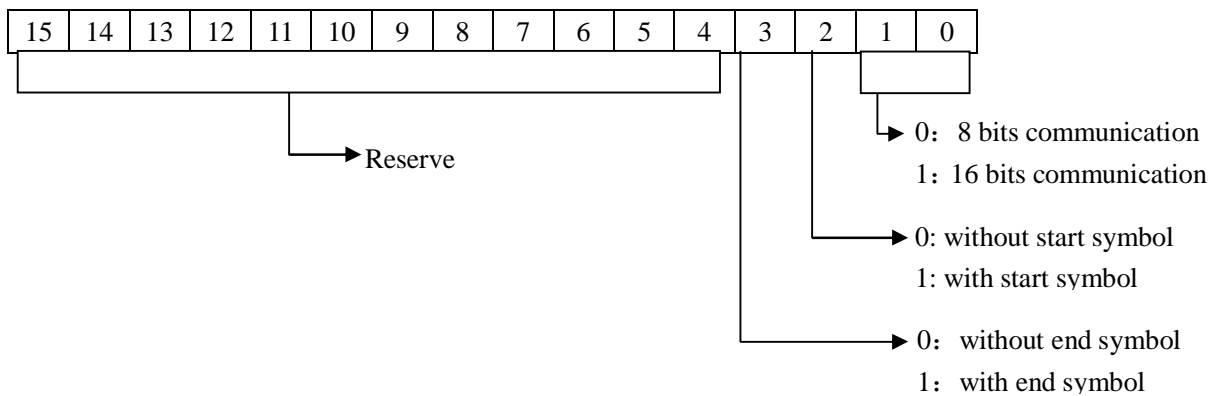

6-3-1. MODBUS Communication function

**Communication
Function**

XC series PLC support both Modbus master and Modbus slave
 Master format: When PLC is set to be master, PLC sends request to other slave devices via Modbus instructions, other devices response the master.
 Slave format: when PLC is set to be slave, it can only response with other master devices.
 The defaulted status of XC-PLC is Modbus slave.

**Communication
ID**

For the soft unit's number in PLC which corresponds with Modbus address number, please see the following table:

Coil space:

Coil's start ID (Dec.)	M0	X0	Y0	S0	M8000	T0	C0
Corresponded Modbus ID (Hex.)	0	4000	4800	5000	6000	6400	6C00

Note: coil's Modbus ID=Modbus ID which corresponds with coil's start ID +coil number

Register space:

Register's start ID (Dec.)	D0	TD0	CD0	D8000	FD0	FD8000
Corresponded Modbus ID (Hex.)	0	3000	3800	4000	4800	6800

Note: register's Modbus ID=Modbus ID which corresponds with register's start ID + register number

Communication Instructions

1、Coil Read [COLR]

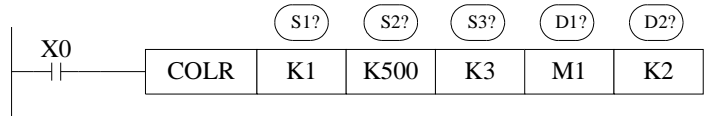

- Coil read instruction, Modbus function code is 01H .
Function: Read the assigned bureau's assigned coil status to PLC's assigned coil.
- (S1?) Far away communication bureau number . Operands: K、TD、CD、D、FD
- (S2?) Far away coil's start number. Operands: K、TD、CD、D、FD
- (S3?) Coil number. Operands: K、TD、CD、D、FD
- (D1?) Local receive coil's start ID. Operands: X、Y、M、S、T、C
- (D2?) Port number. Bound: K1~K2

2、Input Coil's Read [INPR]

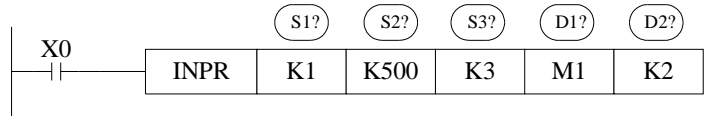

- Read the input coil instruction, Modbus function code is 02H
Function: Read the assigned bureau's assigned input coil status to PLC's assigned coil.
- (S1?) Far away communication bureau number . Operands: K、TD、CD、D、FD
- (S2?) Far away coil's start number. Operands: K、TD、CD、D、FD
- (S3?) Coil number. Operands: K、TD、CD、D、FD
- (D1?) Local receive coil's start ID. Operands: X、Y、M、S、T、C
- (D2?) Port number. Bound: K1~K2

Instruction description: when X0 is ON, execute COLR or INPR instruction. After finish executing the instruction, set communication finish bit. No operation when X0 is OFF. If communication errors, resend automatically. If reach 10 times, set communication error flag. User can check the relative register to judge the reason.

3、Single coil write [COLW]

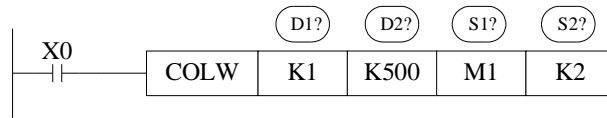

- Write single coil instruction, Modbus function code is 05H
 Function: Write the assigned coil status to PLC's assigned bureau's assigned coil.
 - (D1?) Far away communication bureau number . Operands: K、TD、CD、D、FD
 - (D2?) Far away communication bureau number . Operands: K、TD、CD、D、FD
 - (S1?) Local receive coil's start ID. Operands: X、Y、M、S、T、C
 - (S2?) Port number. Bound: K1~K2

4、Multi-coil write [MCLW]

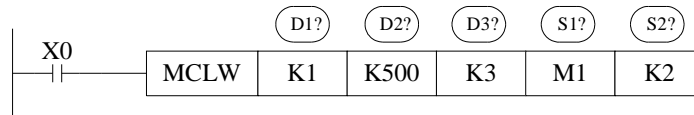

- Write multi-coil instruction, Modbus function code is 0FH。
 Function: Write the assigned multi-coil status to PLC's assigned bureau's assigned coil.
 - (D1?) Far away communication bureau number. Operands: K、TD、CD、D、FD
 - (D2?) Far away communication bureau number. Operands: K、TD、CD、D、FD
 - (D3?) Coil number. Operands: K、TD、CD、D、FD
 - (S1?) Local receive coil's start ID. Operands: X、Y、M、S、T、C
 - (S2?) Port number. Bound: K1~K2

Instruction description: when X0 is ON, execute COLW or MCLW instruction. After finish executing the instruction, set communication finish bit. No operation when X0 is OFF. If communication errors, resend automatically. If reach 10 times, set communication error flag. User can check the relative register to judge the reason.

5、Register Read [REGR]

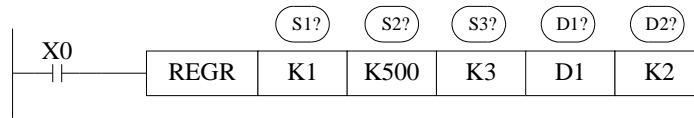

- Read register instruction, Modbus function code is 03H.

Function: Read the assigned bureau's assigned register status to PLC's assigned register.

- (S1?) Far away communication bureau number. Operands: K、TD、CD、D、FD
- (S2?) Far away communication bureau number. Operands: K、TD、CD、D、FD
- (S3?) Register number. Operands: K、TD、CD、D、FD
- (D1?) Local receive register's start ID. Operands: D
- (D2?) Port number. Bound: K1~K2

6、Input Register Read [INRR]

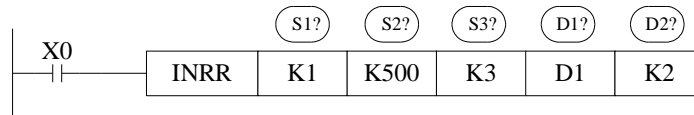

- Read the input register instruction, Modbus function code is 04H.

Function: Read the assigned bureau's assigned input register status to PLC's assigned register.

- (S1?) Far away communication bureau number. Operands: K、TD、CD、D、FD
- (S2?) Far away communication bureau number. Operands: K、TD、CD、D、FD
- (S3?) Register number. Operands: K、TD、CD、D、FD
- (D1?) Local receive register's start ID. Operands: D
- (D2?) Port number. Bound: K1~K2

Instruction description: when X0 is ON, execute REGR or INRR instruction. After finish executing the instruction, set communication finish bit. No operation when X0 is OFF. If communication errors, resend automatically. If reach 10 times, set communication error flag. User can check the relative register to judge the reason.

7、Single Register Write [REGW]

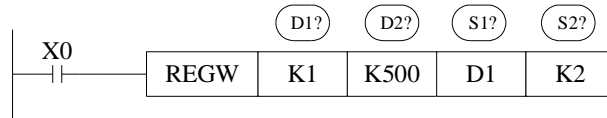

- Write single register instruction, Modbus function code is 06H
Function: write the assigned register status to PLC's assigned bureau's assigned register.
 - (D1?) Far away communication bureau number. Operands: K、TD、CD、D、FD
 - (D2?) Far away communication bureau number. Operands: K、TD、CD、D、FD
 - (S1?) Local receive register's start ID. Operands: D
 - (S2?) Port number. Bound: K1~K2

8、Multi-register Write [MRGW]

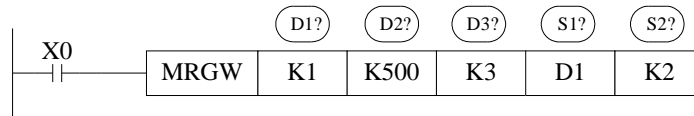

- Write multi-register instruction, Modbus function code is 10H
Function: write the assigned input register status to PLC's assigned bureau's assigned register.
 - (S1?) Far away communication bureau number. Operands: K、TD、CD、D、FD
 - (S2?) Far away communication bureau number. Operands: K、TD、CD、D、FD
 - (S3?) Register number. Operands: K、TD、CD、D、FD
 - (D1?) Local receive register's start ID. Operands: D
 - (D2?) Port number. Bound: K1~K2

Instruction description: when X0 is ON, execute REGW or MRGW instruction. After finish executing the instruction, set communication finish bit. No operation when X0 is OFF. If communication errors, resend automatically. If reach 10 times, set communication error flag. User can check the relative register to judge the reason.

Free Communication

Communication Mode:

Start Symbol (1 byte)	Data Block (max. 128 bytes)	End Symbol (1 byte)
-----------------------	-----------------------------	---------------------

- Baud Rate: 300bps~115.2Kbps
- Data Format
 - Data Bit: 7bits、8bits
 - Check Bit: Odd、 Even、 No Check
 - Stop bit: 1 bit、 2 bits
- Start Symbol: 1 bit
End Symbol: 1 bit
User can set a start/end symbol, after set start/end symbol, PLC will automatically add this start/end symbol when sending data; remove this start/end symbol when receiving data.
- Communication Format: 8 bits、 16 bits
If choose 8 bits cushion format to communicate, in the communication process, the high bytes are invalid, PLC only use the low bytes to send and receive data.

Free format communication transfer data in the format of data block, each block can transfer 128 bytes at most. Meanwhile each block can set a start symbol and end symbol, or not set.

Instruction Format

1、 Send Data:

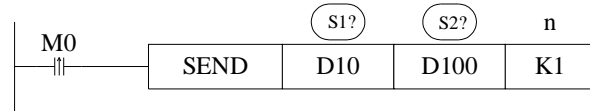

- Data sending instruction, send data every rising edge of M0
 - S1? Start address of send data. Operands: K、TD、CD、D、FD
 - S2? The sent character's number. Operands: K、TD、CD、D、FD
 - n: COM port** Bound: K1~K2
- In the data sending process, "sending" flag M8122 (COM 1) sets ON.

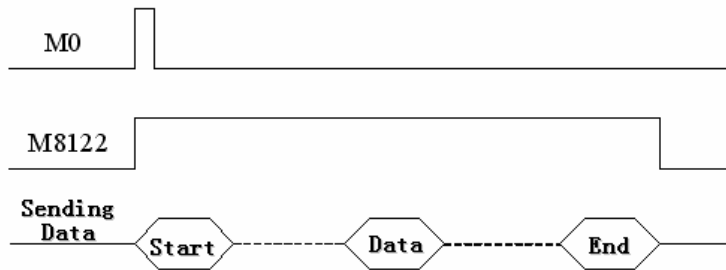

2、 Receive Data:



- Data receiving instruction, receive data every rising edge of M0
 - S1? Receive address of send data. Operands: K、TD、CD、D、FD
 - S2? The received character's number. Operands: K、TD、CD、D、FD
 - n: COM port** Bound: K1~K2
- In the data receiving process, "receiving" flag M8124 (COM 1) sets ON.

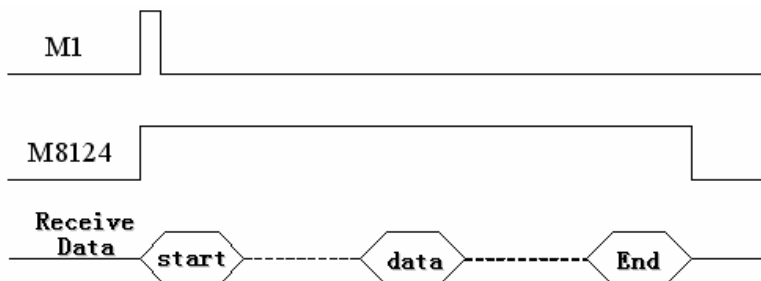

6-4. PWM Pulse Width Modulation		Suitable Model: XC3、XC5
<u>16 bits instruction:</u> PWM	<u>32 bits instruction:</u> -	

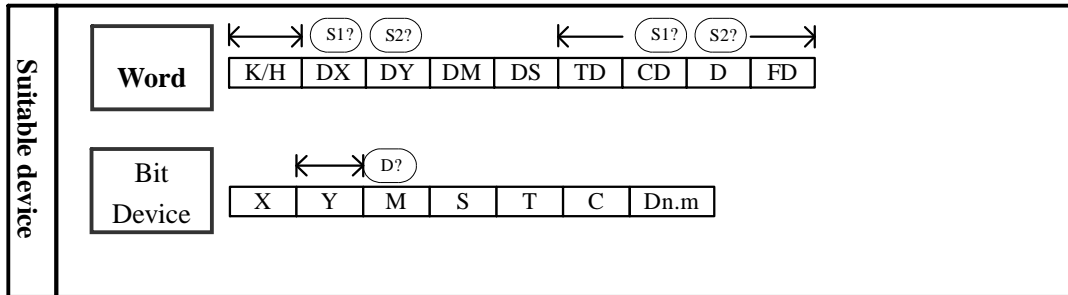

Function and Action

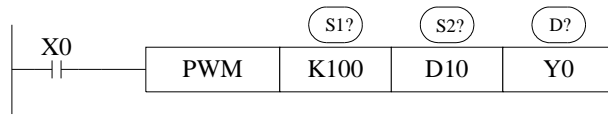

(S1?) Assign occupy/empty ratio value “n”. The bound is: 1~255

(S2?) Assign output frequency f. The bound is: 0~72KHz

(D?) Assign Y number of output pulse

Can only output at Y000 or Y001 (please treat as transistor output type).

- The output occupy/empty ratio of PMW = $n/256 \times 100\%$
- PWM output use the unit of 0.1Hz, so when set (S1) frequency, the set value is 10 times of the actual frequency (i.e. 10f). E.g.: to set the frequency as 720Hz, then set value in (S1) as 720000.
- When X000 is ON, output PWM wave; when X000 is OFF, stop outputting. PMW output doesn't have pulse accumulation.

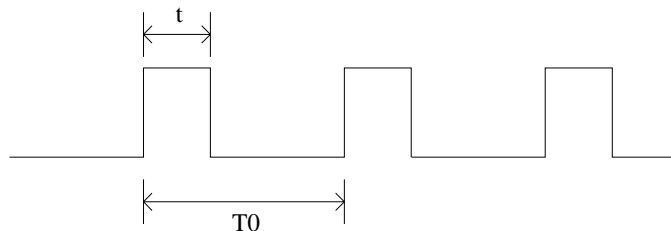

In the upward graph: $T0=1/f$
 $T/T0=n/256$

6-5. Frequency Testing		Suitable Model: XC3、XC5
<u>16 bits instruction:</u> FRQM	<u>32 bits instruction -</u>	

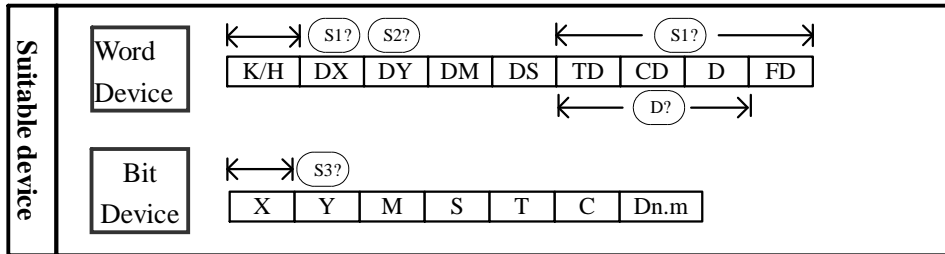

Function and Action

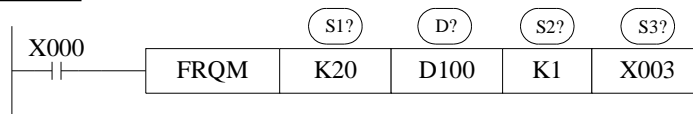

S1: Pulse cycle number (The sampled pulse cycle number in one scan cycle.)

Operands: D、CD、TD

D: Testing result. Operands: D、CD、TD

S2: Frequency division choice. Bound: K1 or K2;

When the frequency division is K1, the bound is: no less than 9Hz, precision bound: 9~18KHz.

When the frequency division is K2, the bound: no less than 300Hz, precision bound: 300~400KHz.

S3: pulse input X number

- In frequency testing, if choose frequency division as K2, the frequency testing precision is higher than frequency division K1.
- When X000 is ON, FRQM will test 20 pulse cycles from X003 every scan cycle. Calculate the frequency's value and save into D100. Test repeatedly. If the tested frequency's value is smaller than the test bound, then return the test value as 0.

The correspond X number with the pulse output of frequency testing:

Model		X
XC3 series	14 points	X2、X3
	24/32 points	X1、X11、X12
	48/60 points	X4、X5
XC5 series	32 points	X3
	48/60 points	X1、X11、X12

6-6. Precise Time		Suitable Model: XC3、XC5
<u>16 bits instruction:</u> STR	<u>32 bits instruction:</u> -	

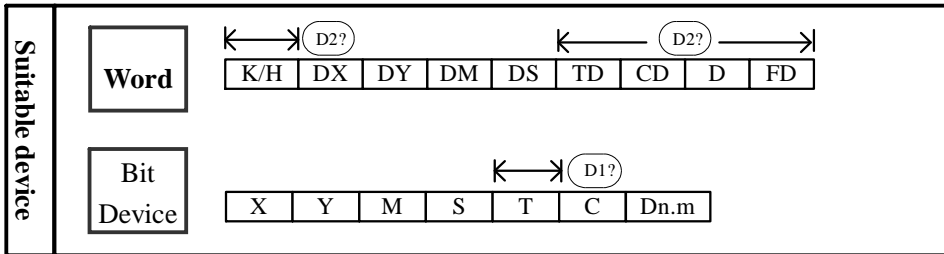

功能和动作

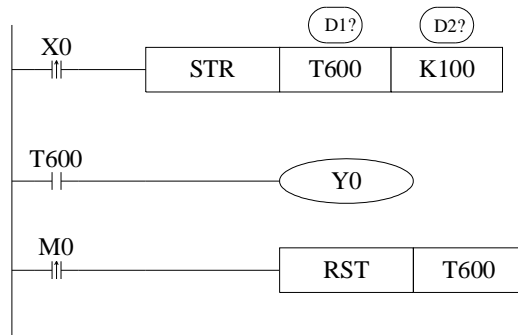

- (D1?): Timer's number. The bound: T600~T618 (T600、T602、T604...T618)
- (D2?): The time value.

- This instruction is the precise time instruction with the cycle of 1ms.
- Precise timer is 32 bits, the count value's bound is 0~+2,147,483,647.
- When X000 turns from OFF to ON, timer T600 starts to time, when time accumulation reaches 100ms, T600 set; if X000 again turns from OFF to ON, timer T600 turns from ON to OFF, restart to time, when time accumulation reaches 100ms, T600 again reset. See the following chart.

SFC graph of the preceding program is:

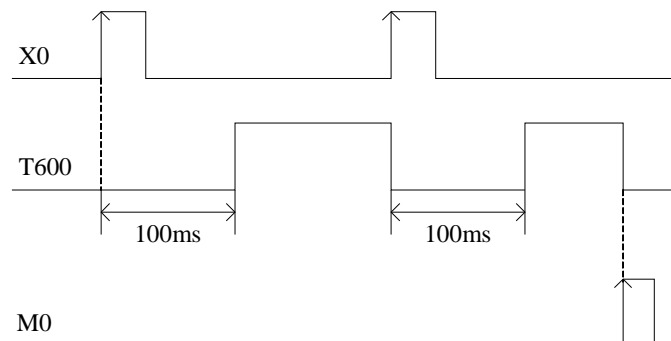

**Precise
Time
Interruption**

- When precise time reaches the count value, a correspond interrupt tag will be generated, some interrupt subroutines can be executed.
- Each precise timer has its correspond interrupt tag. See the following graph:

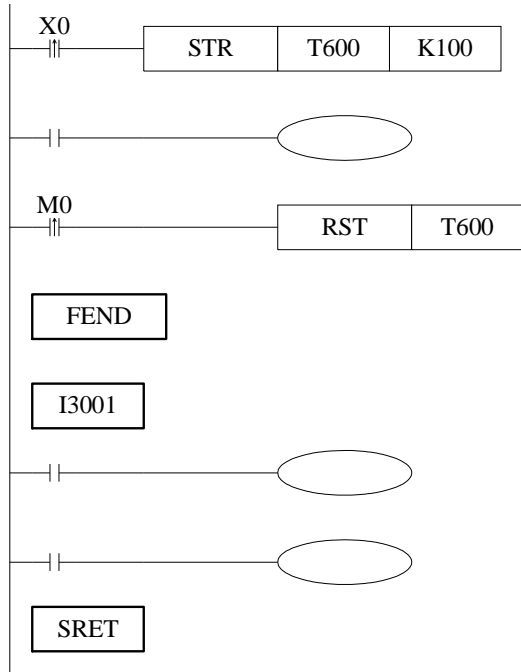

When X000 turns from OFF to ON, timer T600 starts to time, when time reaches 100ms, T600 set; at the same time an interruption occurs, the program jump to interrupt tag I3001 and execute an interruption subroutine.

Interrupt tag correspond with the timer:

Timer's number	Interrupt tag
T600	I3001
T602	I3002
T604	I3003
T606	I3004
T608	I3005
T610	I3006
T612	I3007
T614	I3008
T616	I3004
T618	I3010

6-7. Interruption Function

XC series PLC all have interrupt function. There are two kinds of interrupt function: external interrupt and time interrupt. Via interrupt function, some special program can be disposed, not affected by PLC's scan cycle.



Input terminal X can be used as external interrupt's input, each input terminal corresponds with an external interrupt, the rising edge or falling edge of each input can both active the interrupt. The interrupt subroutine is written behind the main program (Behind FEND command). When interrupt activates, the main program will immediately stop executing, turn to execute the correspond interrupt subroutine. After finish executing the interrupt subroutine, go on execute the main program.

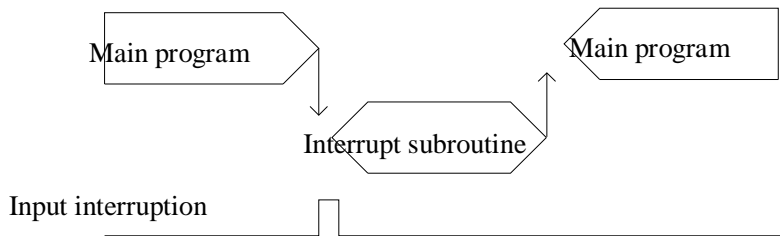

Definition of external interrupt port:

XC3-14 models

Input terminal	Pointer's tag		Forbid interrupt instruction
	Rising interrupt	Falling interrupt	
X7	I0000	I0001	M8050

XC3-24/32 models、XP-18 and XC5-48/60 models

Input terminal	Pointer's tag		Forbid interrupt instruction
	Rising interrupt	Falling interrupt	
X2	I0000	I0001	M8050
X5	I0100	I0101	M8051
X10	I0200	I0201	M8052

XC3-48/60 models

Input terminal	Pointer's tag		Forbid interrupt instruction
	Rising interrupt	Falling interrupt	
X11	I0000	I0001	M8050
X10	I0100	I0101	M8051
X7	I0200	I0201	M8052

Interrupt Instruction

Enable Interruption [EI]、Disable Interruption [DI] and Interrupt Return [IRET]

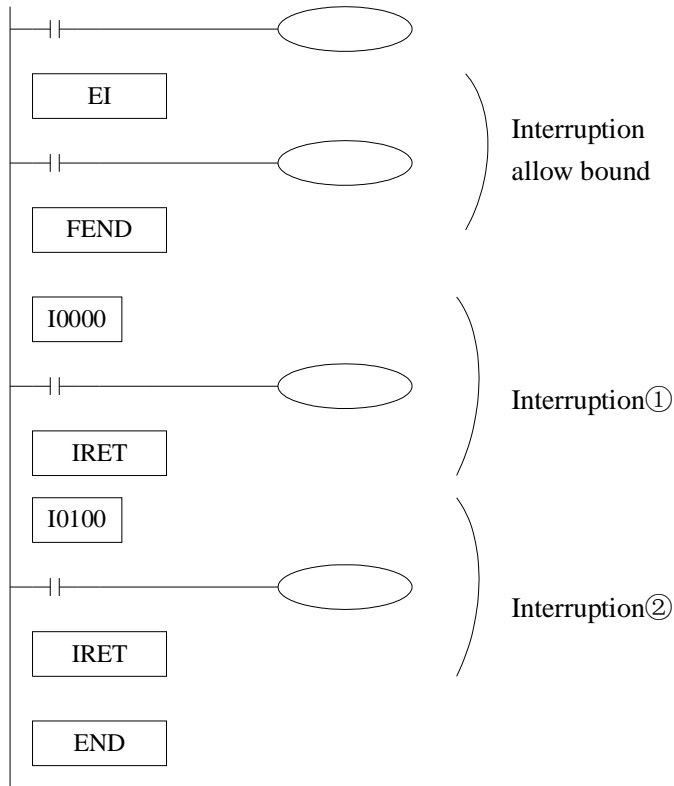

- Normally PLC is in the status of disable interruption, if use EI instruction of allow interruption, then in the process of scan the program, if interrupt input changes from OFF to ON, then execute interrupt subroutine①、②, return to the initial program after that.
- The pointer (I****) used as interruption tag should be behind , FEND command.

《Limitation of interrupt bound》

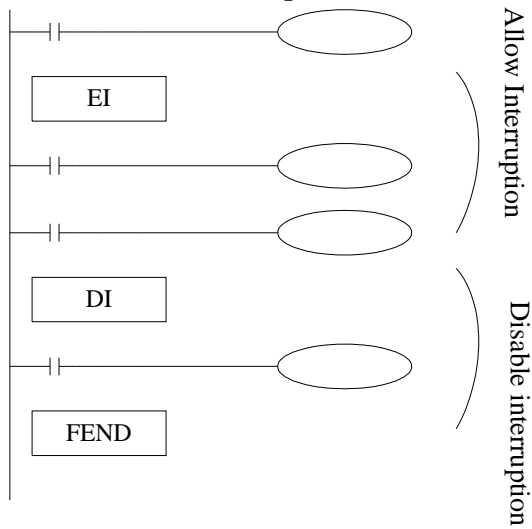

- Via DI instruction, you could set interruption disabled area.
- In EI~DI area, interrupt input is allowed.
- When don't need interrupt disabled, please program only with EI instruction, needn't program with DI instruction.

《Disable Interruption》

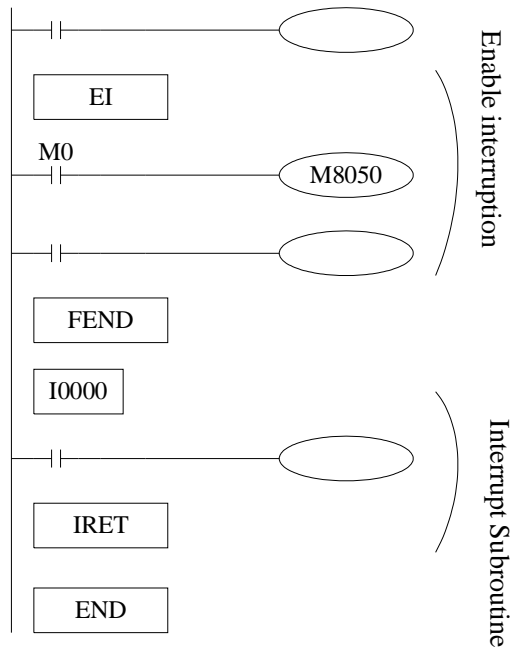

- To each input interruption, special relay of disable interruption is given. (M8050~M8052)
- In the left program, if use M0 to make M8050 “ON”, then disable the interrupt input of route 0

6-7-2. Time Interrupt

Function and Action

In the condition of the main program's executing cycle too long, if certain special program should be executed; or in sequential control scan, a special program should be executed every certain time, time interruption function is suitable. It could be not affected by PLC's scan cycle, execute the time interrupt program every **Nms**.

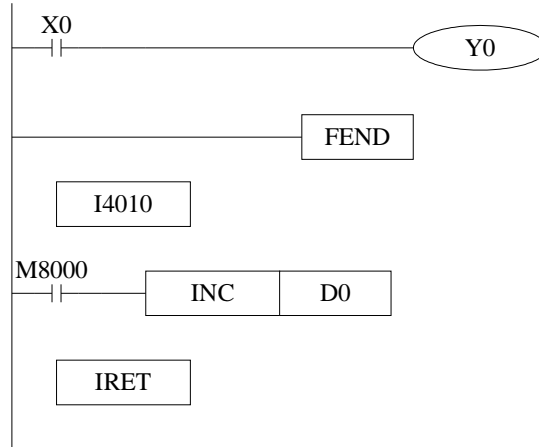

- The defaulted time interruption status is open. Time interrupt subroutine is similar with other interrupt subroutines. It must be written behind the main program, start with I40xx instruction, end with IRET.
- There are 10 routes time interruption, the denote method is: I40**~I49**. (** means time interrupt's time, the unit is ms.)E.g. I4010 means execute the first route's interruption every 10ms.

Table of interruption tag:

Interruption tag	Disable interruption instruction	Description
I40**	M8056	“**” denotes the time of time interrupt. The bound is 1~99, unit is “ms”.
I41**	M8057	
I42**	M8058	
I43**	-	
I44**	-	
I45**	-	
I46**	-	
I47**	-	
I48**	-	
I49**	-	

《Limitation of interruption's bound》

- Normally time interruption is in the status of enable.
- Use EI、DI instructions can set enable interruption/ disable interruption bound. See the preceding graph, in DI~EI section, all time interruption are disabled, while beyond DI~EI section, all time interruption are enabled.

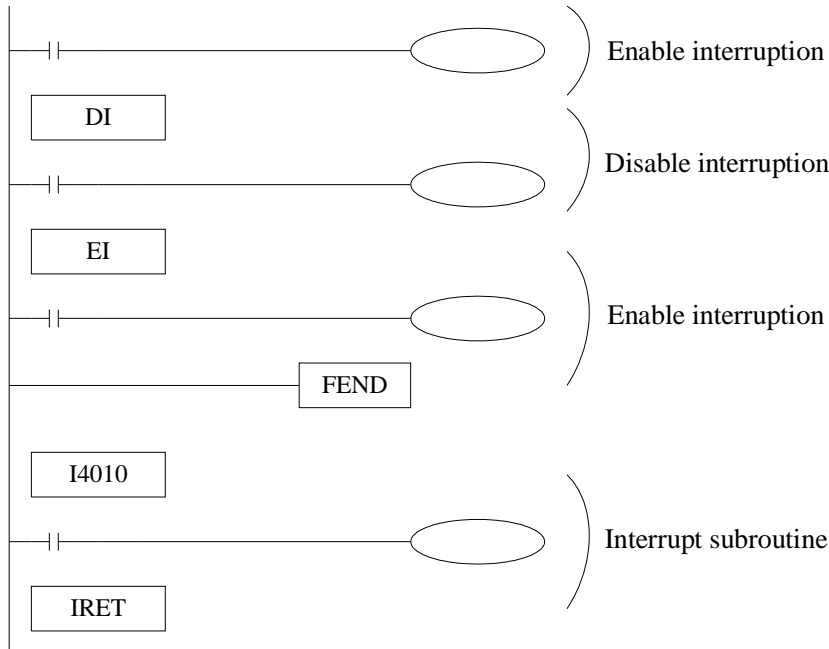

《Disable Interruption》

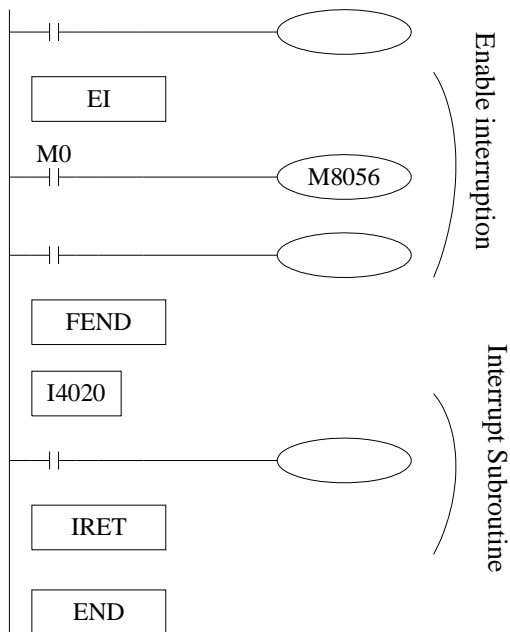

- For the first 3 routes' time interruption, special relay of disable interruption is given. (M8056~M8059)
- In the left example program, if use M0 to make M8056 "ON", then disable the time interruption of route 0.

6-8. CAN-Bus Function (XC5 Series)

● CAN-Bus Brief Introduction

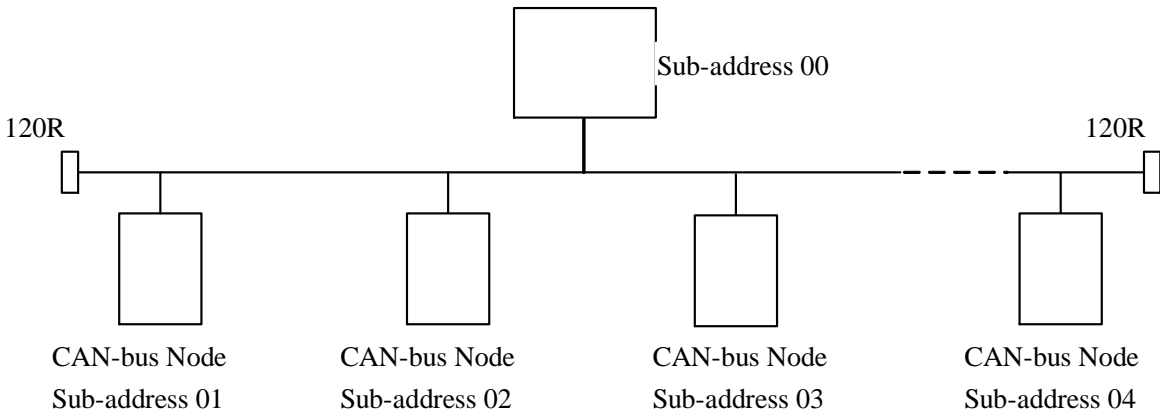

CAN: Controller Area Network, included in industrial area bus category. Compared with common communication bus, CAN bus data communication has performance of outstanding dependability, real time ability and flexibility.

CAN controller works under multi-master format. In the network, each node can send data to bus according to the bus visit priority. These characters make each node in CAN bus network has stronger data communication real time performance, and easy to construct redundant structure, improve the system's dependability and flexibility.

In CANBUS network, any node can initiatively send message at any time to any other node, no master and no slave. Flexibility communication, it's easy to compose multi-device backup system, distributing format monitor, control system. To fulfill different real time requirement, the nodes can be divided to be different priority level. With non-destroy bus arbitrament technology, when two nodes send message to the network at the same time, the low level priority node initiatively stop data sending, while high level priority node can continue transferring data without any influence. So there is function of node to node, node to multi-node, bureau broadcasting sending/receiving data. Each frame's valid byte number is 8, so the transfer time is short, the probability ratio is low.

● External Connection

CAN-Bus Communication Port: CAN+, CAN-

The connection among each node of CAN bus is shown in the following, at the two ends, add 120 ohm middle-terminal resistors.

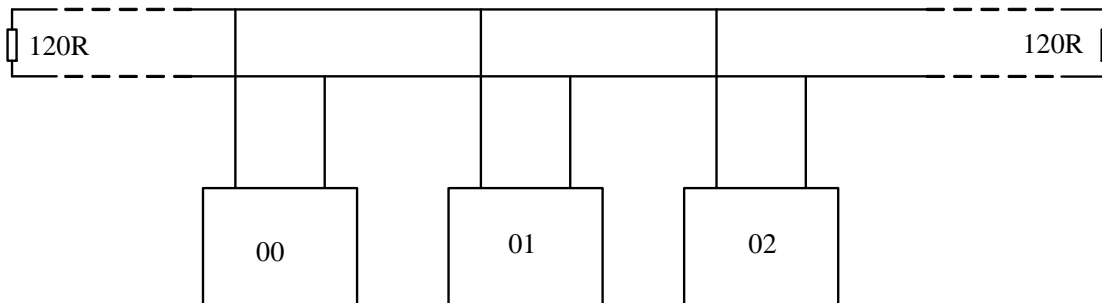

● **Network Format of CAN Bus**

There are two forms of CAN bus network: one is statements communication format; the other is interior protocol communication format. These two forms can carry on at the same time.

➤ Statements communication format

This format means, in the local PLC program, via CAN-bus instructions, carry on bit or word reading/writing with the assigned far away PLC.

➤ Interior protocol communication format

This format means, via setting of special register, with collocate table format, realize allude with each other among PLC's certain device's space. In this way, realize PLC source sharing in CAN-bus network.

一、CAN-bus Statements

● Coil read statement

Function: Read the assigned bureau's assigned coil status into the local assigned coil.

- (S1?) Far away communication bureau ID
- (S2?) Far away coil's start number. Operands: K、M
- (S3?) Coil's number
- (D?) This master's receiving coil's start ID. Operand: M

1、Coil write [CCOLW]

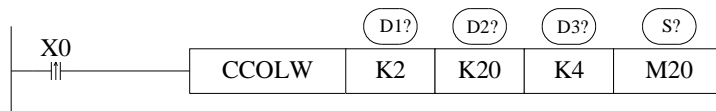

● Coil write statement

Function: Write the local assigned multi-coil's status into the assigned bureau's assigned coil

- (D1?) Far away communication bureau ID
- (D2?) Far away coil's start number.
- (D3?) Coil's number
- (S?) The master's sending coil's start ID. Operand: M

2、Register read [CREGR]

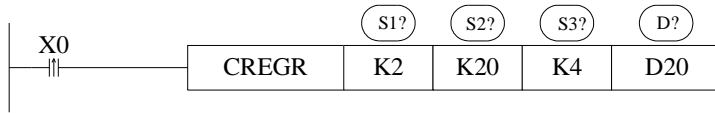

- Read register statement

Function: Read the assigned bureau's assigned register to the local assigned register.

(S1?) Far away communication bureau ID.

(S2?) Far away register's start number. Operands: K、D

(S3?) Register number.

(D?) Local receiving register's start ID. Operand: D

3、Register write [CREGW]

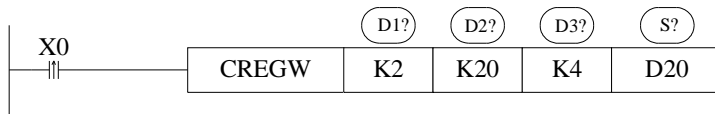

- Write register statement

Function: Write the local assigned input register into the assigned bureau's assigned register.

(D1?) Far away communication bureau ID.

(D2?) Far away register's start number.

(D3?) Register number.

(S?) Local receiving register's start ID. Operand: D

● **Interior protocol communication format**

Function description:

- Open and close of interior protocol communication function
Using via setting the data of register FD8350:
0 means not use CAN interior protocol communication; 1 means use CAN interior protocol communication
CAN interior protocol communication function is defaulted closed.

- Communication parameters setting
Setting of baud rate、bureau ID、and sending frequency these parameters are shown below:

- Definition of configure items
Interior protocol communicates via setting configure items.
There are four configure items: read bit's item, read word's item, write bit's item, write word's item.
Configure format:
Step 1、Add separately four configure item's number: FD8360—read bit's item、FD8361—read word's item、FD8362—write bit's item、FD8363—write word's item.
Step 2、configure each item's communication object, each item needs to set four parameters: according to the order: far away node's bureau ID、far away node's object ID、local object's ID、number. The correspond register ID: FD8370~FD8373 means item 1、FD8374~FD8377 means item 2、.....FD9390~FD9393 means item 256; totally 256 configure items can be set.

CAN Communication Setting

ID	Function	Description
FD8350	CAN communication mode	0 means not use; 1 means interior protocol

FD8351	CAN baud rate	Refer to CAN baud rate setting table
FD8352	Self's CAN bureau ID	CAN protocol using (the defaulted value is 1)
FD8354	Configured sending frequency	The set value's unit is ms (sending one time every several ms) Set to be 0 means sending every cycle, the defaulted value is 5ms
FD8360	Read bit's item	-
FD8361	Read word's item	
FD8362	Write bit's item	
FD8363	Write word's item	
FD8370	Far away node ID	Item 1 configure
FD8371	Far away node's object ID	
FD8372	The local object's ID	
FD8373	number	
.....
FD9390	Far away node ID	Item 256 configure
FD9391	Far away node's object ID	
FD9392	Local object's ID	
FD9393	Number	

CAN baud rate setting table:

FD8351 setting value	Baud rate (BPS)
----------------------	-----------------

0	1K
1	2K
2	5K
3	10K
4	20K
5	40K
6	50K
7	80K
8	100K
9	150K
10	200K
11	250K
12	300K
13	400K
14	500K
15	600K
16	800K
17	1000K

CAN node status:

M8350	Configure item 1	Reset after receiving confirmation
M8351	Configure item 2	
M8352	Configure item 3	
M8353	Configure item 4	
M8354	Configure item 5	
M8355	Configure item 6	
M8356	Configure item 7	
M8357	Configure item 8	
M8358	Configure item 9	
:		
M8605	Configure item 256	

CAN status flag:

M8240	CAN self-check error flag	If error, set 1, if correct, set 0;
-------	---------------------------	-------------------------------------

M8241	CAN configure check error flag	If error, set 1, if correct, set 0;
M8242	CAN bus self-recover control after error	If set to be 1, then automatic self recover after error generate If set to be 0, then after error generate, CAN stop working The defaulted value is 1, not retentive after power cut

CAN status register:

D8240	CAN error message	0: No error 2: Initializing error 30: Bus error 31: Error alarm 32: Data overflow
D8241	Generate error's configure item number	Show configure item error's nearest number
D8242	The sending data package number each second	-
D8243	The receiving data package number each second	-
D8244	CAN communication error number	-

7. Applied Example Programs

In this chapter, we give you some sample programs for your reference.

XC series PLC is mini model、high speed、good performance PLC. Besides the independent using of I/O points, pulse output and other functions could be used. So XC series PLC could satisfy diverse control.

7-1. Example of Pulse Output

7-2. Example of MODBUS Instructions

7-3. Example of Free Format Communication

7-1. Example of Pulse Output

E.g: The following is the program which realize continuous sending high-low pulse

The parameters:

Parameters of step motor: step square angle =1.8 degree/step, fractionlet =40, the pulse number of a round is 8000。

High frequency pulse: max frequency is 100KHz, the total pulse number is 24000 (3 rounds)

Low frequency pulse: Max frequency 10KHz, total pulse number is 8000 (1 round)

Ladder program:

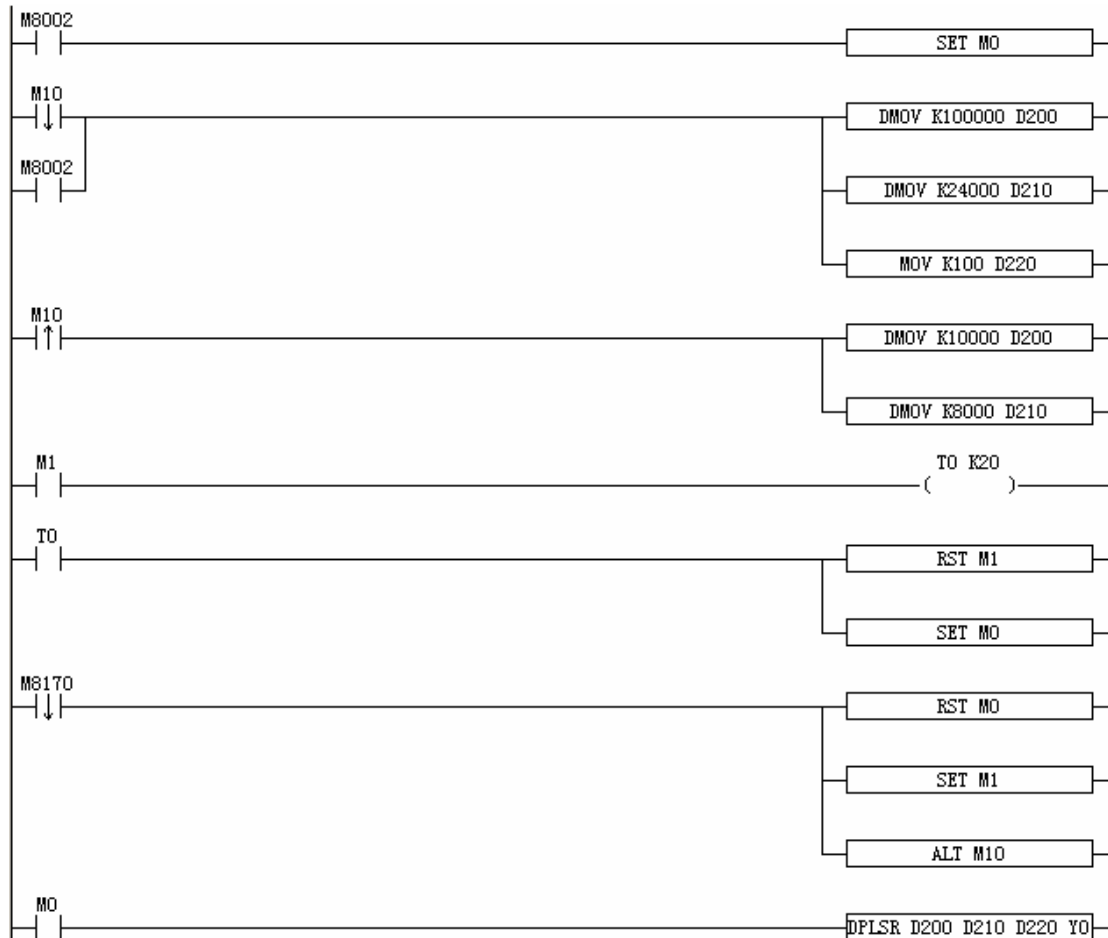

Statement Program:

```

LD      M8002           //Initially forth pulse coil
SET     M0              //Set M0 ON
LDF    M10             //M10 falling edge trigger condition
DMOV   K100000 D200    //Transfer decimal data 100000 into double-word register D200
DMOV   K24000 D210     // Transfer decimal data 24000 into double-word register D210
MOV    K100 D220       // Transfer decimal data 100 into word register D220
LDP    M10             //M10 rising edge trigger condition
DMOV   K10000 D200     // Transfer decimal data 10000 into double-word register D200
DMOV   K8000 D210      // Transfer decimal data 8000 into double-word register D210
LD     M1              //M1 status trigger condition
    
```

```

OUT    T0  K20           //100ms counter T0, time 2 seconds
LD     T0                //T0 status trigger condition
SET    M1                //set M1
SET    M0                // set M1
LDF    M8170            //M8170 falling edge trigger condition
RST    M0                //reset M0
RST    M1                // reset M1
ALT    M10              //M10 status reverse
LD     M0                //M0 status trigger condition
DPLSR  D200  D210  D220  Y0 //Take value is D200 as frequency、 value in D210 as pulse
                                   number、 value in D220 as speedup/speed-down time, send
                                   pulse via Y0

```

Program description:

When PLC changes from STOP to RUN, M8002 coil gets through a scan cycle, set high frequency pulse parameters into D200、 D210, set speedup/speed-down time into D220, set M0, the motor start to speedup with high frequency and work 3 rounds, set coil M8170 at the same time; the motor runs 3 rounds, the speed-down till stop, coil M8170 reset. Here reset M0, set M1, reverse M10 status, set low frequency parameters into D200、 D210. the counter starts to delay with 2 seconds, when reach this 2 seconds, M1 is reset, M0 is set again, the motor starts to run 1 round with low frequency. After finish this 1 round, the motor starts to run with high frequency again! In this format, the motor runs with high frequency and low frequency.

7-2. Example of MODBUS Instructions

E.g.: The following is the communication program of one master station and 4 slave stations

Each parameters:

The master station number is 1, slave stations numbers are 2, 3, 4, 5. This example, we use COM 2:

Ladder program:

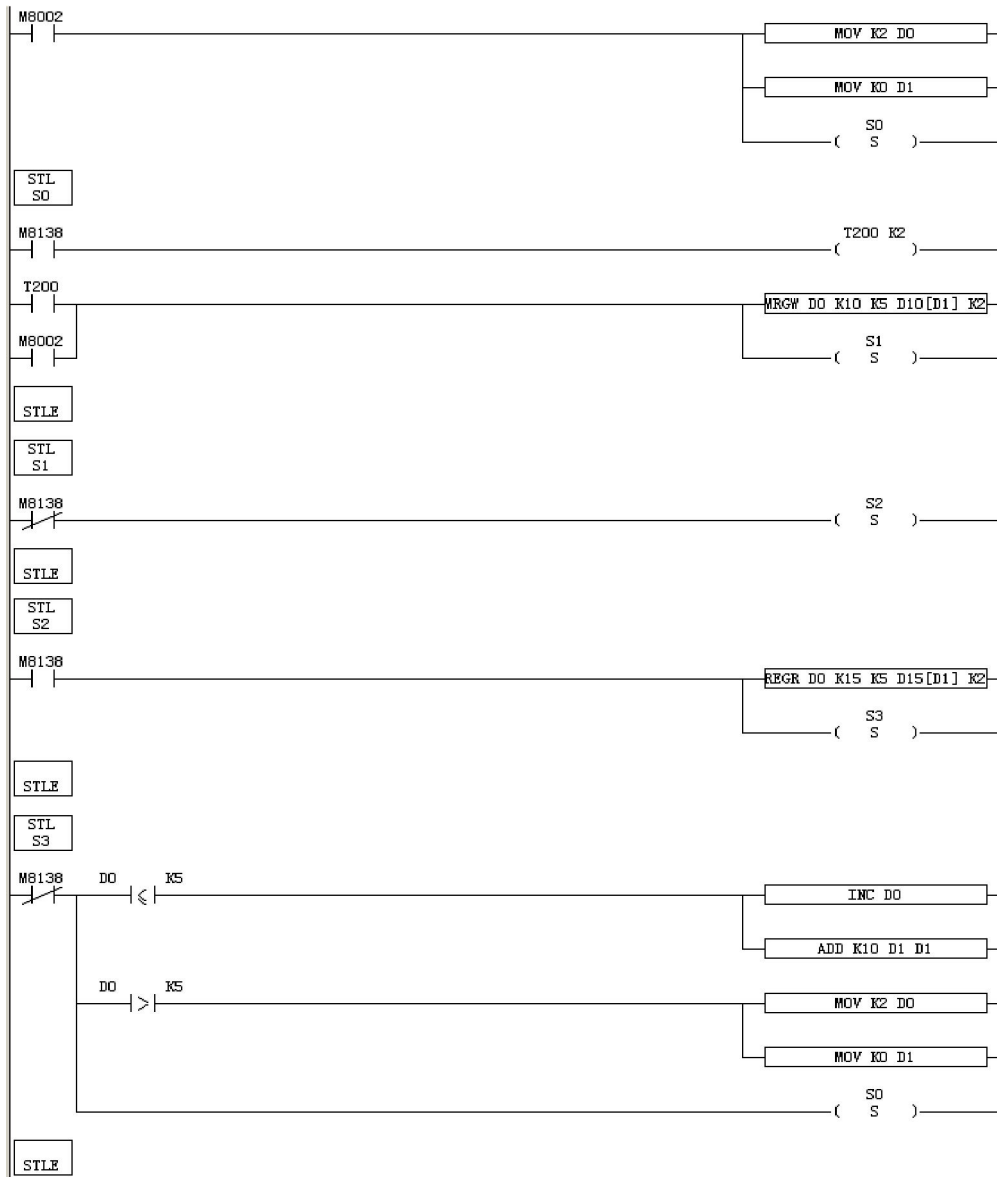

Program description:

When PLC changes from STOP to RUN, M8002 coil gets through a scan cycle. S0 flow open, write master machine's D10—D14 into No.2 slave machine's D10—D14. after finish communication, set M8138, at the same time write slave machine's D15—D19 into master machine's D15—D19, set communication finish flag. Realize write and read to a slave station. At this time flow S3 will judge with the slave station. If the station number is less than 5, station number add 1, offset add 10; or else station number starts from number 2 station again.

7-3. Example of free format communication

This example is the free format program with DH107/DH108 series instruments:

I、Interface specification

DH107/DH108 series instruments use asynchronism serial communication ports, the interface level fits the standard of RS232C or RS485. the data format is 1 start bit, 8 bits data, no check bit, one or two stop bits. Baud rate of communication transfer data could modified to be 1200~19200bit/s

II、Format of communication instructions

DH107/108 instruments use Hex. data format to indicate each instruction code and data.

Read/write instruction:

Read: The address code +52H (82) +parameter's (to read) code+0+0+CRC check code

Write: The address code +43H (67) + parameter's (to write) code +the write data's low byte +the write data's high byte +CRC check code

Read instruction's CRC check code is: parameter's (To read) code *256+82+ADDR

ADDR is instrument's ID value, the bound is 0~100 (please do not add 80H). CRC is the redundant caused by the following operation: the preceding data operate with binary 16 bits integer plus. The redundant is 2 bytes, the low byte is ahead, the high byte is behind

Write instruction's CRC check code is: parameter's (to write) code *256+67+parameter's (to write) value +ADDR

The parameter's (to write) value is indicated by Hex. binary integer

No matter write or read, the instruments will return the following data

The test value PV+ the given value SV+ the output value MV and alarm status + read/written parameter's value +CRC check code

PV、SV and the read parameter's value should be integer format, each engrosses 2 bytes, MV engrosses one byte, the data bound is 0~220, the alarm status engrosses one byte, CRC check code engross 2 bytes, the total is 10 bytes.

CRC check code is PV+SV+(alarm status *256+MV)+parameter's value +ADDR, the redundant caused by the integer plus

(the detailed format, please refer to AIBUS communication protocol description) .

III、Compile communication program

After power on, the program read the current temperature value every 40ms. In this period the user could also write the set temperature value.

Data area definition: send data buffer area: D10~D19

Accept data buffer area: D20~D29

Instrument's station ID: D30

Read command's value: D31=52 H

Write command's value: D32=43 H

Parameter's code: D33

Temperature setting: D34

CRC check code: D36

Temperature display: D200,D201

Format of sending data: 81H 81H 43H 00H c8H 00H 0cH 01H (display of the current temperature)

Setting of communication parameters: baud rate: 9600, 8 bits data bit, 2 bits stop bit, no check.

Set FD8220=255; FD8221=5。

Note (both the host machine and the slave machine should use the version higher than V2.4)

Program:

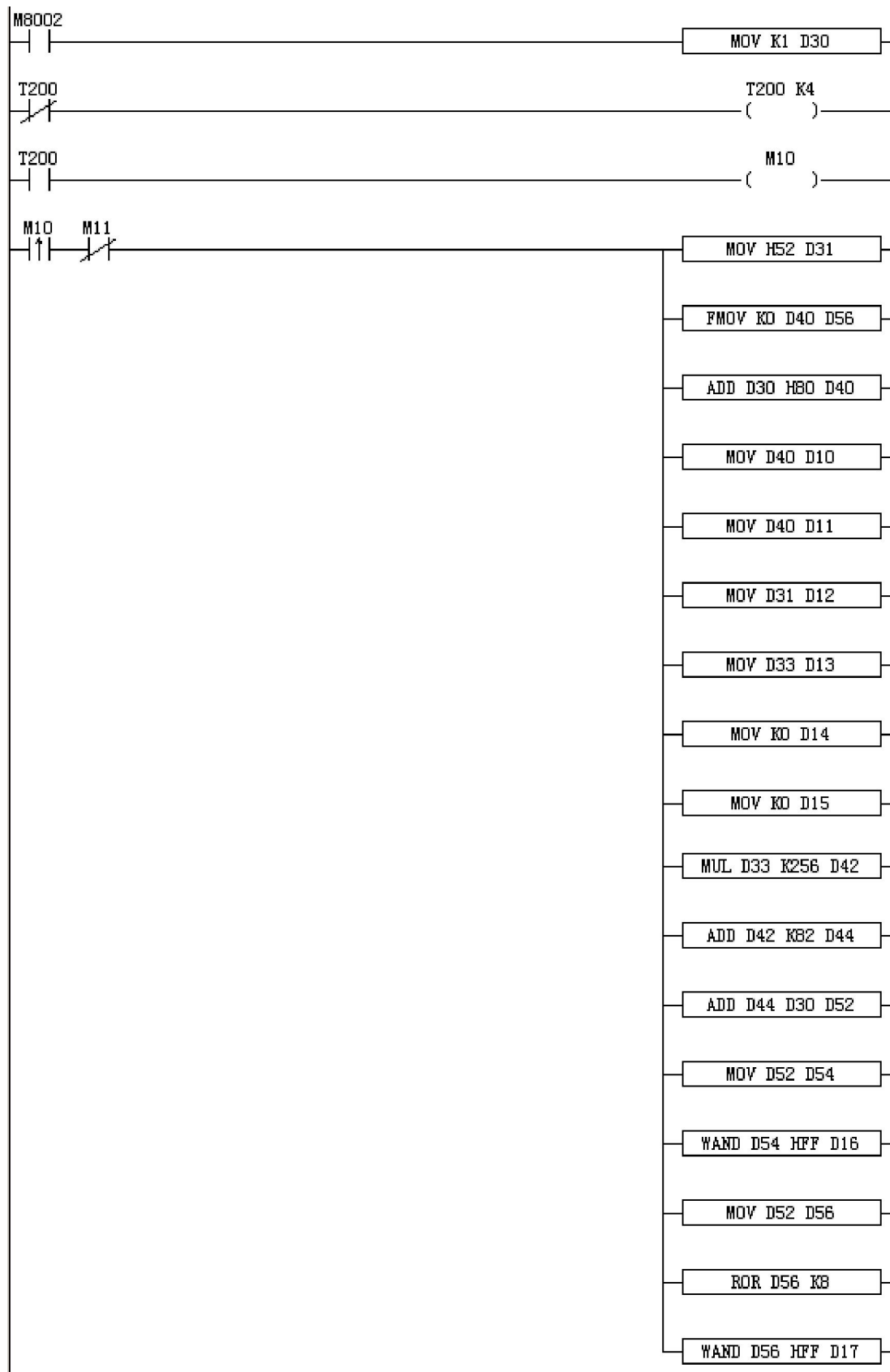

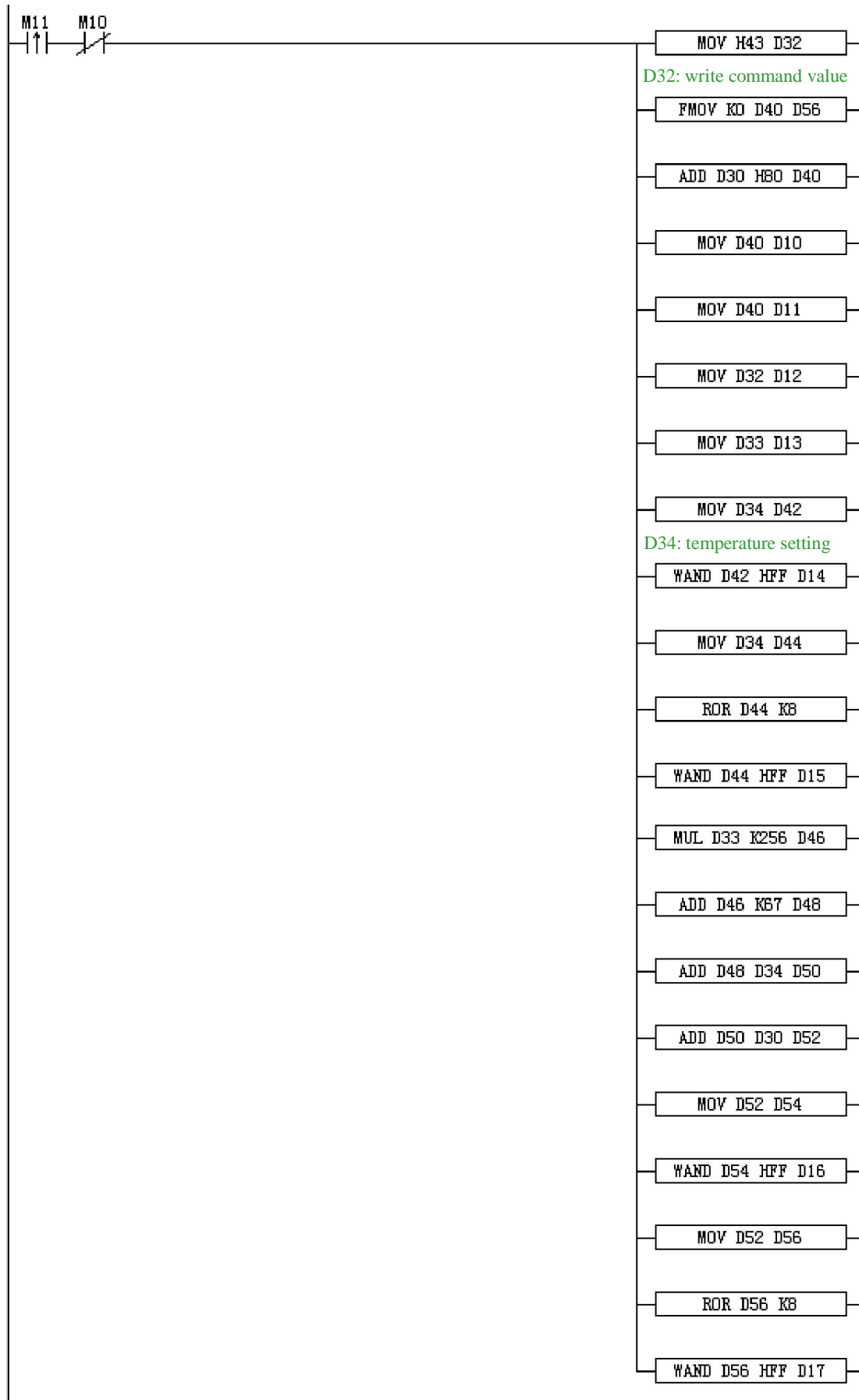

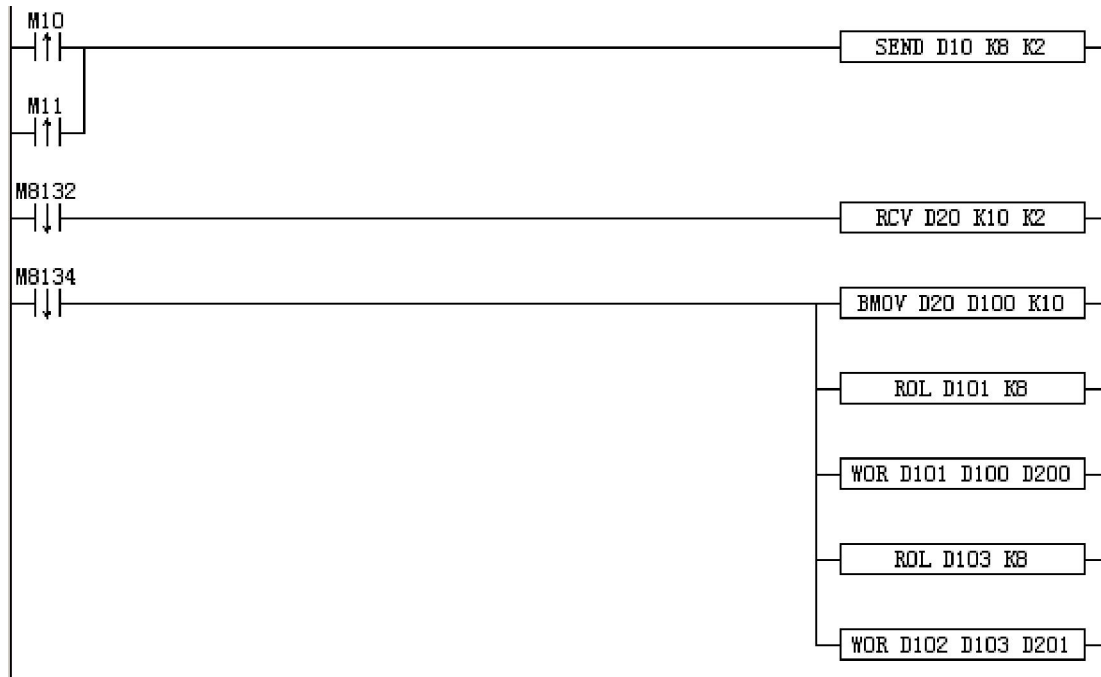

Memo

8. Appendix

This chapter gives some auxiliary information of XC series PLC.

8-1. List of special auxiliary relay, special data register

8-2. List of Special FLASH data register SFD

8-3. Brief Introduction of XC1 series PLC

8-4. Brief Introduction of XC5 series PLC

8-1. List of special auxiliary relay、special data register

Special soft unit's type and its function

PC status (M)

ID	Function	Description	
M8000	Working normally ON coil		PLC be ON when running
M8001	Working normally OFF coil		PLC be OFF when running
M8002	Initial positive pulse coil		The first scan cycle is ON when PLC starts running
M8003	Initial negative pulse coil		The first scan cycle is OFF when PLC starts running
M8005	Battery voltage too low		Act when battery voltage abnormal too low

PC status (D)

ID	Function	Description
D8002	Register's capacity	2...2K steps; 4...4K steps; 8...8K steps
D8005	Battery voltage	0.1V unit

Clock (M)

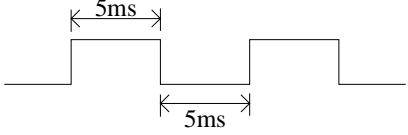
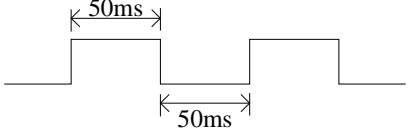
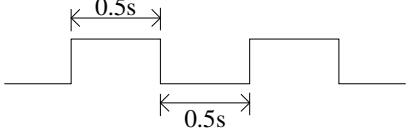
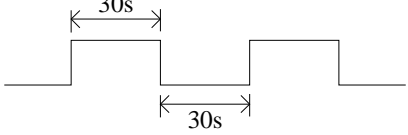
ID	Function	Description
M8010		
M8011	Shake with the cycle of 10ms	
M8012	Shake with the cycle of 100ms	
M8013	Shake with the cycle of 1	
M8014	Shake with the cycle of 1	
M8018	Bits of year	Defaulted is OFF (OFF: 2; ON: 4)

Flag (M)

ID	Function	Description
M8020	Zero	When plus/minus operation result is 0
M8021	Borrow	When borrow occurs in minus operation
M8022	Carry	When carry occurs in plus operation or overflow occurs in bit shift operation
M8023		
M8026	RAMP mode	
M8029		

Clock (D)

ID	Function	Description
D8010	The current scan cycle	Unit: 0.1ms
D8011	Mini value of scan time	Unit: 0.1ms
D8012	Max vale of scan time	Unit: 0.1ms
D8013	Second (clock)	0~59 (BCD code format)
D8014	Minute (clock)	0~59 (BCD code format)
D8015	Hour (clock)	0~23 (BCD code format)
D8016	Date (clock)	0~31 (BCD code format)
D8017	Month (clock)	0~12 (BCD code format)
D8018	Year (clock)	2000~2099 (BCD code format)
D8019	Week (clock)	0 (Sunday) ~6 (Saturday) (BCD code format)

Flag (D)

ID	Function	Description
D8021	Model	Low byte
	Serial number	High byte
D8022	Compatible system's version number	Low byte
	System's version number	High byte
D8023	Compatible model's version number	Low byte
	Model's version number	High byte
D8024	Model's information	Max 5 ASC and a" \0"
D8025		
D8026		
D8027	Suitable host machine version	
D8028		
D8029		

PC mode (M)

ID	Function	Description
M8030	PLC initializing	
M8031	Non-retentive register clear	When driving this M, ON/OFF image memory of Y, M, S, TC and the current value of T, C, D are all cleared
M8032	Retentive register clear	
M8033	Register retentive stop	When PLC changes from RUN to STOP, leave all content in image register and data register
M8034	All output forbidden	Set PC's all external contacts to be OFF status
M8038	Parameter setting	Communication parameters set flag

PC mode (D)

ID	Function	Description
D8030		
D8031		
D8032		
D8033		
D8034		
D8035		
D8036		
D8037		
D8038		

Step ladder (M)

ID	Function	Description
M8041		
M8045	All output reset forbidden	When mode shifting, all output reset are forbidden
M8046	STL status act	When M8047 acts, act when any unit of S0~S999 turns to be ON

Interrupt (M)

ID	Function	Description
M8050 I000□	Forbid input interruption 0	After executing EI, even interruption allowed, but when M acts at this time, the correspond input interruption couldn't act separately E.g.: when M8050 is ON, interrupt I000□ is forbidden
M8051 I010□	Forbid input interruption 1	
M8052 I020□	Forbid input interruption 2	
M8053 I030□	Forbid input interruption 3	
M8054 I040□	Forbid input interruption 4	
M8055 I050□	Forbid input interruption 5	
M8056 I40□□	Forbid time interruption 0	After executing EI, even interruption allowed, but when M acts at this time, the correspond input interruption couldn't act separately
M8057 I41□□	Forbid time interruption 1	
M8058 I42□□	Forbid time interruption 2	
M8059	Interrupt forbidden	Forbid all interruption

Error check (M)

ID	Function	Description
M8067	Operation error	Power on and STOP->RUN check
M8070	Scan overtime	
M8071	No user program	Interior codes checking error
M8072	User program error	Execute code or collocate table check error

Error check (D)

ID	Function	Description
D8067	Execute error code's ID	Error of divide
D8068	Lock occur error code's ID	
D8069		
D8070	Scan time of overtime	Unit: 1ms
D8074	ID of Excursion register D	
D8097		
D8098		

Communication (M)

	ID	Function	Description
COM1	M8120		
	M8122	RS232 is sending flag	
	M8124	RS232 is receiving flag	
	M8125	Receive imperfect flag	Receiving finished normally, but the received data is less than the required
	M8127	Receive error flag	
	M8128	Receive correct flag	
	M8129	Timeout judgment flag	
COM2	M8130		
	M8132	RS232 is sending flag	
	M8134	RS232 is receiving flag	
	M8135	Receive imperfect flag	Receiving finished normally, but the received data is less than the required
	M8137	Receive error flag	
	M8138	Receive correct flag	
	M8139	Timeout judgment flag	
COM3	M8140		
	M8142	RS232 is sending flag	
	M8144	RS232 is receiving flag	
	M8145	Receive imperfect flag	Receiving finished normally, but the received data is less than the required
	M8147	Receive error flag	
	M8148	Receive correct flag	
	M8149	Timeout judgment flag	

Communication (D)

	ID	Function	Description
COM1	D8120		
	D8121		
	D8123	Data number received by RS232	
	D8126		
	D8127	Communication error code	7: hardware error 10: no start sign 8: CRC check error 11: no end sign 9: bureau ID error 12: communication time out
	D8128		
	D8129		
	COM2	D8130	
D8131			
D8133		Data number received by RS232	
D8136			
D8137		Communication error code	7: hardware error 10: no start sign 8: CRC check error 11: no end sign 9: bureau ID error 12: communication time out
D8138			
D8139			
COM3		D8140	
	D8141		
	D8143	Data number received by RS232	
	D8146		
	D8147	Communication error code	7: hardware error 10: no start sign 8: CRC check error 11: no end sign 9: bureau ID error 12: communication time out
	D8148		
	D8149		

High speed count (M)

ID	Counter ID	Function	Description
M8150	C600	Count finished sign	24 segments count finished, flag is 1
M8151	C602	Count finished sign	24 segments count finished, flag is 1
M8152	C604	Count finished sign	24 segments count finished, flag is 1
M8153	C606	Count finished sign	24 segments count finished, flag is 1
M8154	C608	Count finished sign	24 segments count finished, flag is 1
M8155	C610	Count finished sign	24 segments count finished, flag is 1
M8156	C612	Count finished sign	24 segments count finished, flag is 1
M8157	C614	Count finished sign	24 segments count finished, flag is 1
M8158	C616	Count finished sign	24 segments count finished, flag is 1
M8159	C618	Count finished sign	24 segments count finished, flag is 1
M8160	C620	Count finished sign	24 segments count finished, flag is 1
M8161	C622	Count finished sign	24 segments count finished, flag is 1
M8162	C624	Count finished sign	24 segments count finished, flag is 1
M8163	C626	Count finished sign	24 segments count finished, flag is 1
M8164	C628	Count finished sign	24 segments count finished, flag is 1
M8165	C630	Count finished sign	24 segments count finished, flag is 1
M8166	C632	Count finished sign	24 segments count finished, flag is 1
M8167	C634	Count finished sign	24 segments count finished, flag is 1
M8168	C636	Count finished sign	24 segments count finished, flag is 1
M8169	C638	Count finished sign	24 segments count finished, flag is 1

Pulse output (M)

ID	High frequency pulse ID	Function	Description
M8170	PULSE_1	Sending pulse flag	Be 1 at pulse sending
M8171		32 bits pulse sending overflow flag	Be 1 when overflow
M8172		Direction flag	1 is positive direction, the correspond direction port is ON
M8173	PULSE_2	Sending pulse flag	Be 1 at pulse sending
M8174		32 bits pulse sending overflow flag	Be 1 when overflow
M8175		Direction flag	1 is positive direction, the correspond direction port is ON
M8176	PULSE_3	Sending pulse flag	Be 1 at pulse sending
M8177		32 bits pulse sending overflow flag	Be 1 when overflow
M8178		Direction flag	1 is positive direction, the correspond direction port is ON
M8179	PULSE_4	Sending pulse flag	Be 1 at pulse sending
M8180		32 bits pulse sending overflow flag	Be 1 when overflow
M8181		Direction flag	1 is positive direction, the correspond direction port is ON

Positive/negative count

ID	Counter's ID	Function	Description
M8238	C300~C498	Control of positive/negative count	0 is plus count, 1 is minus count, the defaulted is 0
.....			

High speed count (D)

ID	Counter's ID	Function	Description
D8150	C600	The current segment (means No.n segment)	
D8151	C602	The current segment	
D8152	C604	The current segment	
D8153	C606	The current segment	
D8154	C608	The current segment	
D8155	C610	The current segment	
D8156	C612	The current segment	
D8157	C614	The current segment	
D8158	C616	The current segment	
D8159	C618	The current segment	
D8160	C620	The current segment	
D8161	C622	The current segment	
D8162	C624	The current segment	
D8163	C626	The current segment	
D8164	C628	The current segment	
D8165	C630	The current segment	
D8166	C632	The current segment	
D8167	C634	The current segment	
D8168	C636	The current segment	
D8169	C638	The current segment	

Pulse output (D)

ID	High frequency pulse ID	Function	Description
D8170	PULSE_1	The low 16 bits of accumulated pulse number	
D8171		The high 16 bits of accumulated pulse number	
D8172		The current segment (means No.n segment)	
D8173	PULSE_2	The low 16 bits of accumulated pulse number	
D8174		The high 16 bits of accumulated pulse number	
D8175		The current segment (means No.n segment)	
D8176	PULSE_3	The low 16 bits of accumulated pulse number	Only XC5-32RT-E (4 pulse) have
D8177		The high 16 bits of accumulated pulse number	
D8178		The current segment (means No.n segment)	
D8179	PULSE_4	The low 16 bits of accumulated pulse number	
D8180		The high 16 bits of accumulated pulse number	
D8181		The current segment (means No.n segment)	
D8190	PULSE_1	The low 16 bits of accumulated pulse number	
D8191		The high 16 bits of accumulated pulse number	
D8192	PULSE_2	The low 16 bits of accumulated pulse number	
D8193		The high 16 bits of accumulated pulse number	
D8194	PULSE_3	The low 16 bits of accumulated pulse number	Only XC5-32RT-E (4 pulse) have
D8195		The high 16 bits of accumulated pulse number	
D8196	PULSE_4	The low 16 bits of accumulated pulse number	
D8197		The high 16 bits of accumulated pulse number	

Expansion's information (D)

Unit	Type	ID (as register)	Max I/O//channels
Expansion 1#	Input switch quantity X	X100~X137	32 points
	Output switch quantity Y	Y100~Y137	32 points
	Input analog ID	ID100~ID131	16 channels
	Output analog QD	QD100~QD131	16 channels
	Module's set value D	D8250~D8259	-
Expansion 2#	Input switch quantity X	X200~X237	32 points
	Output switch quantity Y	Y200~Y237	32 points
	Input analog ID	ID200~ID231	16 channels
	Output analog QD	QD200~QD231	16 channels
	Module's set value D	D8260~D8269	-
Expansion 3#	Input switch quantity X	X300~X337	32 points
	Output switch quantity Y	Y300~Y337	32 points
	Input analog ID	ID300~ID331	16 channels
	Output analog QD	QD300~QD331	16 channels
	Module's set value D	D8270~D8279	-
Expansion 4#	Input switch quantity X	X400~X437	32 points
	Output switch quantity Y	Y400~Y437	32 points
	Input analog ID	ID400~ID431	16 channels
	Output analog QD	QD400~QD431	16 channels
	Module's set value D	D8280~D8289	-
Expansion 5#	Input switch quantity X	X500~X537	32 points
	Output switch quantity Y	Y500~Y537	32 points
	Input analog ID	ID500~ID531	16 channels
	Output analog QD	QD500~QD531	16 channels
	Module's set value D	D8290~D8299	-
Expansion 6#	Input switch quantity X	X600~X637	32 points
	Output switch quantity Y	Y600~Y637	32 points
	Input analog ID	ID600~ID631	16 channels
	Output analog QD	QD600~QD631	16 channels
	Module's set value D	D8300~D8309	-
Expansion 7#	Input switch quantity X	X700~X737	32 points
	Output switch quantity Y	Y700~Y737	32 points
	Input analog ID	ID700~ID731	16 channels
	Output analog QD	QD700~QD731	16 channels
	Module's set value D	D8310~D8319	-
BD Expansion	Input switch quantity X	X1000~X1037	32 points
	Output switch quantity Y	Y1000~Y1037	32 points
	Input analog ID	ID1000~ID1031	16 channels
	Output analog QD	QD1000~QD1031	16 channels
	Module's set value D	D8320~D8329	-

8-2. List of special FLASH data register SFD

1、 I filter

Number	Function	Description
FD8000	X port, input filter time value	Unit: ms
FD8002		
FD8003		
FD8004		
FD8005		
FD8006		
FD8007		
FD8008		
FD8009		

2、 I mapping

Number	Function	Description
FD8010	X00 corresponds with I**	X0 corresponds with the number of input image I**
FD8011	X01 corresponds with I**	
FD8012	X02 corresponds with I**	
.....	
FD8073	X77 corresponds with I**	

3、 O mapped

Number	Function	Description
FD8074	Y00 corresponds with I**	Y0 corresponds with the number of input image O**
FD8075	Y01 corresponds with I**	
FD8076	Y02 corresponds with I**	
.....	
FD8137	Y77 corresponds with I**	

4、 I property

Number	Function	Description
FD8138	X00 property	0: positive logic; others: negative logic
FD8139	X01 property	
FD8140	X02 property	
.....	
FD8201	X77 property	

5、 Device's power failure retentive area

Number	Function	Description
FD8202	Start tag of D power failure store area	
FD8203	Start tag of M power failure store area	
FD8204	Start tag of T power failure store area	
FD8205	Start tag of C power failure store area	
FD8206	Start tag of S power failure store area	

6、Communication

	Number	Function	Description
COM1	FD8210	Communicate mode	255 is free format, 1~254 bits modbus station ID
	FD8211	Communicate format	Baud rate, data bit, stop bit, checkout
	FD8212	Judgment time of ASC timeout	Unit: ms
	FD8213	Judgment time of reply timeout	Unit: ms, if set to be 0, it means no timeout waiting
	FD8214	Start ASC	High 8 bits be of no effect
	FD8215	End ASC	Low 8 bits be of no effect
	FD8216	Free format setting	8/16 bits cushion, with/without start bit, with/without end bit,
	COM2	FD8220	Communicate mode
FD8221		Communicate format	Baud rate, data bit, stop bit, checkout
FD8222		Judgment time of ASC timeout	High 8 bits be of no effect
FD8223		Judgment time of reply timeout	Low 8 bits be of no effect
FD8224		Start ASC	Unit: ms
FD8225		End ASC	Unit: ms, if set to be 0, it means no timeout waiting
FD8226		Free format setting	8/16 bits cushion, with/without start bit, with/without end bit
COM3	FD8230	Communicate mode	255 is free format, 1~254 bits modbus station ID
	FD8231	Communicate format	Baud rate, data bit, stop bit, checkout
	FD8232	Judgment time of ASC timeout	High 8 bits be of no effect
	FD8233	Judgment time of reply timeout	Low 8 bits be of no effect
	FD8234	Start ASC	Unit: ms
	FD8235	End ASC	Unit: ms, if set to be 0, it means no timeout waiting
	FD8236	Free format setting	8/16 bits cushion, with/without start bit, with/without end bit

8-3. Brief Introduction of XC1 Series PLC

8-3-1. Performance

1、Brief Introduction of XC1-PLC

- XC1 series PLC are suitable for small control system which needs little I/O. The main units can not connect with the expansions.
- Special BD boards can be inserted into XC1-PLC main units. This can realize analog sampling and temperature sampling, realize PID control.
- There is no clock function in XC1- PLC, the common register D has no power-off retentive area. If you want to hold data after power off, you can save data in FD register in FlashROM area.
- XC1- PLC can realize logic control, data operation and other common functions, but no high speed counter、 pulse output、 free communication and other special functions.

2、Performance Index

Item		Specification		
		16 points	24 points	32 points
Program executing format		Loop scan format、 time scan format		
Program format		Both statement and ladder		
Dispose speed		0.5us		
Power cut retentive		Use FlashROM		
User program's capacity		2000 steps		
I/O points		8 I / 8 O	12/12	16/16
Interior coil's points (M)		556 points		
Timer (T)	Points	80 points		
	Spec.	100mS timer: Set time 0.1~3276.7 seconds 10mS timer: Set time 0.01~327.67 seconds 1mS timer: Set time 0.001~32.767 seconds		
Counter (C)	Points	48 points		
	Spec.	16 bits counter: set value K0~32767 32 bits counter: set value K0~2147483647		
Data Register (D)		406 words		
FlashROM Register (FD)		510 words		
High speed dispose function		No		
Setting of time scan space		0~99mS		
Password protection		6 bits ASCII		
Self diagnose function		Power on self-diagnose、 Monitor timer、 grammar check		

8-3-2. Statements

XC1 series PLC includes all SFC statements of XC3 series PLC, part of applied statements, no special function statements.

XC1 series PLC has the following applied instructions:

Sort	Mnemonic	Function
Program Flow	CJ	Condition jump
	CALL	Call subroutine
	SRET	Subroutine return
	STL	Flow start
	STLE	Flow end
	SET	Open the assigned flow, close the current flow
	ST	Open the assigned flow, not close the current flow
	FOR	Start of a FOR-NEXT loop
	NEXT	End of a FOR-NEXT loop
	FEND	First end
Data Move	MOV	Move
	BMOV	Block move
	FMOV	Fill move
	FWRT	FlashROM written
	MSET	Zone set
	ZRST	Zone reset
	SWAP	The high and low byte of the destinated devices are exchanged
	XCH	Exchange
Data Operation	ADD	Addition
	SUB	Subtraction
	MUL	Multiplication
	DIV	Division
	INC	Increment
	DEC	Decrement
	MEAN	Mean
	WAND	Word And
	WOR	Word OR
	WXOR	Word exclusive OR
	CML	Compliment
	NEG	Negative

8-3-3. Soft unit's bound:**Soft unit's bound:**

Mnemonic	Name	Bound		Points	
		14 points	24\32 points	14 points	24\32 points
X	Input relay	X000~X007	X000~X013 X000~X017	8 points	12\16 points
Y	Output relay	Y000~Y007	Y000~Y013 Y000~Y017	8 points	12\16 points
M	Interior relay	M0~M319		320	
		M8000~M8370 for special using		256	
S	Flow	S0~S31		32	
T	Timer	T0~T23: 100ms not accumulation		80	
		T100~T115: 100ms accumulation			
		T200~T223: 10ms not accumulation			
		T300~T307: 10ms accumulation			
		T400~T403: 1ms not accumulation			
		T500~T503: 1ms accumulation			
C	Counter	C0~C23: 16 bits forth counter		635	
		C300~C315: 32 bits forth/back counter			
		C600~C634: high-speed counter			
D	Data Register	D0~D149		150	
		For special usage D8000~D8029		512	
		For special usage D8060~D8079			
		For special usage D8120~D8179			
		For special usage D8240~D8249			
		For special usage D8306~D8313			
		For special usage D8460~D8479			
FD	FlashROM Register	FD0~FD411		412	
		For special usage FD8000~FD8009		98	
		For special usage FD8210~FD8229			
		For special usage FD8306~FD8009			
		For special usage FD8000~FD8313			
		For special usage FD83500~FD8409			

8-4. XC5 series PLC

8-4-1. Performance

1、Brief introduction of XC5 series

XC5 series PLC covers all functions of XC1 series、XC3 series, also the interior source space is larger than XC1 and XC3 series;

XC5 series PLC also have CANbus function, which can realize complex communication network function. For the detailed CANbus function, please refer to "[6-8. CAN Bus \(XC5 series\)](#)".

2、Performance Index

Item	Specification		
	32 points	48 points	60 points
Program executing format	Loop scan format、time scan format		
Program format	Both statement and ladder		
Dispose speed	0.5us		
Power cut retentive	Use FlashROM and Li battery		
User program's capacity	2500 steps	10000 steps	
I/O points	18 I / 14 O	28/20	36/24
Interior coil's points (M)	8512 points		
Timer (T)	Points	620 points	
	Spec.	100mS timer: Set time 0.1~3276.7 seconds 10mS timer: Set time 0.01~327.67 seconds 1mS timer: Set time 0.001~32.767 seconds	
Counter (C)	Points	635 points	
	Spec.	16 bits counter: set value K0~32767 32 bits counter: set value K0~2147483647	
Data Register (D)	8512 words		
FlashROM Register (FD)	2048 words		
High speed dispose function	High speed counter, pulse output, external interrupt		
Setting of time scan space	0~99mS		
Password protection	6 bits ASCII		
Self diagnose function	Power on self-diagnose、Monitor timer、grammar check		

8-4-2. Soft unit's bound:

Soft unit's bound:

Mnemonic	Name	Bound		Points	
		32 points	48\60 points	32 points	48\60 points
X	Input relay	X000~X021	X000~X033 X000~X047	18 points	28\36 points
Y	Output relay	Y000~Y015	Y000~Y023 Y000~Y027	14 points	20\24 points
M	Interior relay	M0~M2999 【M3000~M7999】		8000	
		M8000~M8511 for special using		512	
S	Flow	S0~S511 【S512~S1023】		1024	
T	Timer	T0~T99: 100ms not accumulation		620	
		T100~T199: 100ms accumulation			
		T200~T299: 10ms not accumulation			
		T300~T399: 10ms accumulation			
		T400~T499: 1ms not accumulation			
		T500~T599: 1ms accumulation			
		T600~T618: 1ms with interruption precise time			
C	Counter	C0~C299: 16 bits forth counter		635	
		C300~C589: 32 bits forth/back counter			
		C600~C634: high-speed counter			
D	Data Register	D0~D3999 【D4000~D7999】		8000	
		For special usage D8000~D8511		512	
FD	FlashROM Register	FD0~FD1535		4096	
		For special usage FD8000~FD8009		1024	

Memo

