



XC series PLC hardware

User manual

XINJE Electric Co., Ltd.

Data No. PC01 20110106 3.3

Catalog

1 SUMMARY OF XC SERIES PLC	5
1-1. Products Specifications.....	6
1-1-1. CPU Units.....	6
1-1-2. Expansions.....	9
1-2. Model Composing and Model List	10
1-2-1. Name Principle and Model list of CPU units	10
1-2-2. Expansion's name principle and module list.....	13
1-3. Each Part's Description.....	16
2 THE SPECIFICATIONS AND PARAMETERS OF CPU	17
2-1. Specifications and Parameters	18
2-1-1. General Specifications.....	18
2-1-2. Performance and Specifications	19
2-2. External Dimension	27
2-3. Terminals Arrangement.....	29
2-4. Communication Ports	31
3 SYSTEM STRUCTURE.....	32
3-1. System Structure	33
3-2. Peripheral Equipments.....	34
3-2-1. Program Software.....	34
3-2-2. Human Machine Interface (HMI).....	35
3-2-3. Network Module.....	36
3-3. Configuration Principle.....	38
3-4. ID Assignment of Expansions.....	40
3-5. Install the Products	42
4 POWER SUPPLY SPECIFICATION AND WIRING METHOD.....	44
4-1. Power Supply Specifications	45
4-2. AC Power DC Input Type.....	46
5 INPUT SPECIFICATIONS AND WIRING METHODS.....	47
5-1. Input Specification.....	48
5-2. DC Input Signal (AC Power Supply Type).....	49
5-3. High Speed Counter Input	52
5-3-1. Count Mode.....	52
5-3-2. High Speed Count Range	54
5-3-3. The Input Wiring Of HSC	54
5-3-3. Input Terminals Assignment	55
5-3-4. AB Phase Counter's Frequency Multiplication Setting	61
6 OUTPUT SPECIFICATION AND WIRING METHODS.....	62

6-1. Output Specification	63
6-2. Relay Output Type	65
6-3. Transistor Output Type	68
7 RUN、DEBUG、MAINTENANCE	70
7-1. Run and Debug	71
7-2. Daily Maintenance	72
8 EXPANSION DEVICES.....	73
8-1. MODULES SUMMARY	74
8-2. Digital Input/output Modules.....	76
8-3. Analogue、Temperature Modules	79
8-3-1. XC-E8AD	80
8-3-2. XC-E4AD2DA	81
8-3-3. XC-E4AD	82
8-3-4. XC-E4DA	84
8-3-5. XC-E2DA	85
8-3-6. XC-E6PT-P.....	86
8-3-7. XC-E6TCA-P	87
8-3-9. XC-E2AD2PT2DA.....	90
8-4. Expansion BD cards	92
8-4-1. XC-2AD2PT-BD	94
8-4-2. XC-COM-BD	95
9 CHANGE THE SOFT COMPONENTS.....	96
9-1. Function Summary.....	97
9-2. Operation Method	98
9-3. Operated by HMI	99
APPENDIX SPECIAL SOFT DEVICE LIST	102
Appendix 1-1. Special Auxiliary Relay List	103
Appendix 1-2. List of special memory and special data register	110
Appendix 1-3. ID List of the Expansions.....	117
Appendix 1-4. Special Flash Register List.....	121
APPENDIX 2 INSTRUCTIONS LIST.....	126
Appendix 2-1. Basic Instructions List.....	127
Appendix 2-2. Applied instruction list.....	128
Appendix 2-3. Special Instructions List.....	130
Appendix 2-4. MOTION CONTROL INSTRUCTIONS LIST	131
APPENDIX 3 VERSION FOR SPECIAL FUNCTION	133
APPENDIX 4 PLC CONFIGURATION LIST	134
APPENDIX 5 COMMON QUESTION A&Q	136

1 Summary of XC Series PLC

XC series PLC include diverse CPU units and expansions with powerful functions. This chapter will mainly tell the main specifications, the whole products range, each part's description and name template composing the four items.

1-1. Products Specifications

1-2. Model Composing and Model List

1-3. Each Part's Description

1-1. Products Specifications

1-1-1. CPU Units

1 Diverse Models

XC series PLC's CPU units has many subsidiary products line, the combination can be make freely.

- I/O Points: 10、14、16、24、32、42、48、60 points
- Output Type: Transistor、Relay、R/T mixed type
- Input Type: PNP、NPN
- Power Supply Type: AC220V、DC24V
- Subsidiary^{*1} XC1、XC2、XC3、XC5、XCM

Series	Type	Description
XC1	Economic Type	Include 10I/O、16I/O、24I/O、32I/O Suitable for common simple applications which has less I/O requirement, Do not support free communication, expansion, BD cards.
XC2	Basic Type	Include 14I/O、16I/O、24I/O、32I/O、48I/O、60I/O Equipped XC series PLC's basic functions, the CPU unit can't work with expansions, but can work with BD card. Equipped with high speed operation ability.
XC3	Standard Type	Include 14I/O、24I/O、32I/O、42I/O、48I/O、60I/O XC series standard models, equipped with full functions, fulfill the user's diverse requirements
XC5	Strength Type	Include 24I/O、32I/O、48I/O、60I/O Besides XC3 series functions, XC5 series PLC added following functions: 24I/O、32I/O models have 4CH pulse output; 48I/O、60I/O support CAN-bus, users can realize CAN bus network functions
XCM	Motion Control Type	Include 24I/O、32I/O Besides XC series basic functions, XCM models support powerful pulse output functions and rich motion control instruction. The models are designed especially for motion control.
XCC	High speed motion control type	Include 32 I/O. Besides XC series basic function, XCC models support motion control instruction, more pulse output channels and high speed counters.

- Special Type XC3-19AR-E (Combine analogue I/O with digital I/O in one body)

※1: For each subsidiary series model list and functions, please refer to Appendix 4;

※2: XC3-19AR is not included in this manual. For the using method, please refer to 《XC3-19AR-E manual》。

2	Strong Functions
----------	-------------------------

XC series PLC have abundant basic functions and diverse special functions. Each subsidiary series faces to different application field.

Abundant Basic Functions

- **High Speed Operation**
Basic operation instruction 0.2~0.5us, the scan time is 10,000 steps per 5ms, the program space reaches to 160K.
- **Abundant expansions**
The CPU units usually support 7 different expansions and 1 BD card.
- **Multiple Communication Ports**
The CPU units have 1~4 communication ports, support RS232、RS485、CAN bus; it can work with many peripheral devices like inverters, instruments, printers etc.
- **Rich soft device space**
The five subsidiary series of XC series PLC are equipped with different internal resource to apply different requirements.
The resource space reaches: 1024 points flow S、8768 points middle relay M、544 points input relay、544 points output relay、640 points Timer T、640 points counter C、9024 points data register D、2048 points FD、36864 points expansion register ED。
- **2 types of program form**
XC series PLC support 2 types of program form, I.e. instruction list and ladder chart.
The two types can switch to each other;
- **Abundant instructions**
Abundant instructions, besides the basic order control, data transfer and compare, arithmetic, data loop and shift, the PLC also support pulse output, high speed counter, interruption, PID etc.
- **Real time clock**
XC series PLC are equipped with real time clock, for time control;
- **Compact size, convenient to install**
XC series PLC has compact size, convenient to install. User can choose DIN or screw installation style.

Strength Special Functions

- **High Speed Pulse Counter can reach 80KHz**
The CPU units of XC2/XC3/XC5 are equipped with 3 channels, 2 phases high speed counter and high speed counter comparator; can realize single phase, pulse + direction,

AB phase count, the frequency can reach 80KHz.

- Powerful communication & network ability
With multiple communication port and diverse communication protocol like Modbus protocol, free communication protocol etc, it's easy to build the different network; In Modbus network, PLC can be master or slave; XC5 series can build CAN bus; via T-BOX module can build Ether net; via G-BOX can work with GPRS network;
- High Speed Pulse Output can reach 400Hz
XC series PLC^{※1} are generally equipped 2 pulse output terminals, can output 200 KHz pulse; the special model^{※2} has 4 channels pulse output functions
- Interruption Function
XC series PLC have interruption function, including external interruption, time interruption and high-speed counter interruption; they can meet different requirements.
- Switch I/O points freely
XC series PLC can switch I/O in case of terminals broken; there is no need to change the program;
- C language function block
Write the function block with C language. C is good at calculation operations that improve the efficiency;
- PID function on CPU units
The CPU units of XC series PLC^{※1} has PID control and auto tune function.
- Sequential Function Block (BLOCK)
In sequential function Block, users can realize the sequential action of instructions. This function is suitable to apply on pulse output, communication, motion control; inverter read/write etc. This function simplifies the program editing greatly.
- 24 segments high speed counter interruption
There are 24 segments 32 bits initial value in high speed counter of XC series PLC^{※1}
Each segment can generate interruption with perfect real time ability, realize electric cam function;
- PWM pulse width modulation
XC series PLC^{※1} have PWM pulse width modulation; this function can apply to DC motor control;
- Frequency testing
XC series PLC^{※1} can realize frequency testing
- Precise Time
XC series PLC^{※1} can realize precise time; the precise timer is a 32 bits timer of 1ms
- Motion Control
XCM series PLC^{※1} are motion control models, can realize circular interpolation, position control etc.

※1: Here XC series PLC refer to the PLC that can realize the mentioned functions. That is to say, not all XC series PLC can realize the mentioned function. For details, please refer to Appendix 4.

※2: Here the special model refers to XC5-32T-E.

When programming the PLC via XCPPro, users can feel it Humanism and easy to get familiar.

- Switch ladder and instruction list freely
- Offer soft device comment, ladder comment, instruction hint functions etc.
- Offer many types of program interface for special instructions, convenient to write the instructions.
- Perfect monitor mode: ladder monitor, free monitor, soft devices monitor
- Many windows in one interface, convenient to manage.

※1: For the detailed XCP Pro software application, please refer to 《XC series PLC user manual 【software】》.

1-1-2. Expansions

To fulfill the field control requirements better, XC series PLC can work with expansions, each CPU units can link seven expansions.

- Diverse Types
Digital I/O expansions, analogue I/O modules, temperature control modules and mixed function modules etc.
- Compact Size
- DC24V power supply (32I/O modules are AC220V power supply).
- Analogue、temperature modules all include PID tune function.

Digital I/O Modules	Analogue I/O Modules	Temperature Control Modules	Function Mixed Modules
Power Supply: DC24V AC220V Input points: 8-32 Output points: 8-32 Output Type: Relay Transistor	Power Supply: DC24V Type: DA、AD AD/DA DA channel Nr.: 2、4 AD channel Nr.: 4、8	Power Supply: DC24V Temperature: PT100 Thermocouple Temp. Channel Nr.: 6 PID Control: Included	Power Supply: DC24V AD: 3CH Temperature: 4CH PT100 DA: 2CH

2 BD Card

Besides the expansion modules, XC series PLC can also expand by the BD cards. The BD cards are small PCB cards that can insert into PLC from the BD port (on CPU unit), so this kind of expansion does not take extra space.

- Analog temperature: XC-2AD2PT-BD
- Analog: XC-2AD2DA-BD
- Communication: XC-COM-BD
- SD card: XC-SD-BD
- Ethernet: XC-TBOX-BD

※1: User should install and configure before using the BD cards. For details, please refer to: 《XC series BD cards user manual》.

1-2. Model Composing and Model List

1-2-1. Name Principle and Model list of CPU units

1 Name Principle of CPU units

Name principle of XC series PLC CPU units:

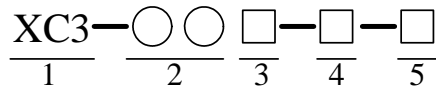

- | | |
|-----------------------|---|
| 1: Series Name | XC1、XC2、XC3、XC5、XCM |
| 2: Input/output Point | 10、14、16、24、32、42、48、60 |
| 3: If Input is NPN | R: Relay output
T: Transistor output
RT: Relay/Transistor mix output (Y0、Y1 are Transistor) |
| If Input is PNP | PR: Relay output
PT: Transistor output
PRT : Relay/Transistor mix output (Y0、Y1 are |

Transistor)

4: Power Supply E: AC Power Supply (220V)

C: DC Power Supply (24V)

※1: Generally, clock and RS485 are standard configuration on communication port. But some models are not included. Please refer to Appendix 4.

2 CPU Units List

● **XC1 Series Model List**

Model					Input points (DC24V)	Output points (R, T)
AC Power Supply		DC Power Supply				
Relay output	Transistor output	Relay output	Transistor output			
N P N	XC1-10R-E	XC1-10T-E	XC1-10R-C	XC1-10T-C	5	5
	XC1-16R-E	XC1-16T-E	XC1-16R-C	XC1-16T-C	8	8
	XC1-24R-E	XC1-24T-E	XC1-24R-C	XC1-24T-C	12	12
	XC1-32R-E	XC1-32T-E	XC1-32R-C	XC1-32T-C	16	16
P N P	XC1-10PR-E	XC1-10PT-E	XC1-10PR-C	XC1-10PT-C	5	5
	XC1-16PR-E	XC1-16PT-E	XC1-16PR-C	XC1-16PT-C	8	8
	XC1-24PR-E	XC1-24PT-E	XC1-24PR-C	XC1-24PT-C	12	12
	XC1-32PR-E	XC1-32PT-E	XC1-32PR-C	XC1-32PT-C	16	16

● **XC2 Series Model List**

Model							Input points (DC24V)	Output points (R, T)
AC Power Supply			DC Power Supply					
Relay output			Relay output	Transistor output	R/T Type			
N P N	XC2-14R-E	XC2-14T-E	XC2-14RT-E	XC2-14R-C	XC2-14T-C	XC2-14RT-C	8	6
	XC2-16R-E	XC2-16T-E	XC2-16RT-E	XC2-16R-C	XC2-16T-C	XC2-16RT-C	8	8
	XC2-24R-E	XC2-24T-E	XC2-24RT-E	XC2-24R-C	XC2-24T-C	XC2-24RT-C	14	10
	XC2-32R-E	XC2-32T-E	XC2-32RT-E	XC2-32R-C	XC2-32T-C	XC2-32RT-C	18	14
	XC2-48R-E	XC2-48T-E	XC2-48RT-E	XC2-48R-C	XC2-48T-C	XC2-48RT-C	28	20
	XC2-60R-E	XC2-60T-E	XC2-60RT-E	XC2-60R-C	XC2-60T-C	XC2-60RT-C	36	24
P	XC2-14PR-E	XC2-14PT-E	XC2-14PRT-E	XC2-14PR-C	XC2-14PT-C	XC2-14PRT-C	8	6

N P	XC2-16PR-E	XC2-16PT-E	XC2-16PRT-E	XC2-16PR-C	XC2-16PT-C	XC2-16PRT-C	8	8
	XC2-24PR-E	XC2-24PT-E	XC2-24PRT-E	XC2-24PR-C	XC2-24PT-C	XC2-24PRT-C	14	10
	XC2-32PR-E	XC2-32PT-E	XC2-32PRT-E	XC2-32PR-C	XC2-32PT-C	XC2-32PRT-C	18	14
	XC2-48PR-E	XC2-48PT-E	XC2-48PRT-E	XC2-48PR-C	XC2-48PT-C	XC2-48PRT-C	28	20
	XC2-60PR-E	XC2-60PT-E	XC2-60PRT-E	XC2-60PR-C	XC2-60PT-C	XC2-60PRT-C	36	24

● **XC3 Series Model List**

Model							Input points (DC24V)	Output points (R, T)
AC Power Supply			DC Power Supply					
Relay output			Relay output	Transistor output	R/T Type			
N P N	XC3-14R-E	XC3-14T-E	XC3-14RT-E	XC3-14R-C	XC3-14T-C	XC3-14RT-C	8	6
	XC3-24R-E	XC3-24T-E	XC3-24RT-E	XC3-24R-C	XC3-24T-C	XC3-24RT-C	14	10
	XC3-32R-E	XC3-32T-E	XC3-32RT-E	XC3-32R-C	XC3-32T-C	XC3-32RT-C	18	14
	XC3-48R-E	XC3-48T-E	XC3-48RT-E	XC3-48R-C	XC3-48T-C	XC3-48RT-C	28	20
	XC3-42R-E	XC3-42T-E	XC3-42RT-E	XC3-42R-C	XC3-42T-C	XC3-42RT-C	24	18
	XC3-60R-E	XC3-60T-E	XC3-60RT-E	XC3-60R-C	XC3-60T-C	XC3-60RT-C	36	24
P N P	XC3-14PR-E	XC3-14PT-E	XC3-14PRT-E	XC3-14PR-C	XC3-14PT-C	XC3-14PRT-C	8	6
	XC3-24PR-E	XC3-24PT-E	XC3-24PRT-E	XC3-24PR-C	XC3-24PT-C	XC3-24PRT-C	14	10
	XC3-32PR-E	XC3-32PT-E	XC3-32PRT-E	XC3-32PR-C	XC3-32PT-C	XC3-32PRT-C	18	14
	XC3-48PR-E	XC3-48PT-E	XC3-48PRT-E	XC3-48PR-C	XC3-48PT-C	XC3-48PRT-C	28	20
	XC3-42PR-E	XC3-42PT-E	XC3-42PRT-E	XC3-42PR-C	XC3-42PT-C	XC3-42PRT-C	24	18
	XC3-60PR-E	XC3-60PT-E	XC3-60PRT-E	XC3-60PR-C	XC3-60PT-C	XC3-60PRT-C	36	24

● **XC5 Series Model List**

Model							Input points (DC24V)	Output points (R, T)
AC Power Supply			DC Power Supply					
Relay output			Relay output	Transistor output	R/T Type			
N P	-	XC5-24T-E	-	-	XC5-24T-C	-	14	10
	-	XC5-32T-E	-	-	XC5-32T-C	-	18	14
N	XC5-48R-E	XC5-48T-E	XC5-48RT-E	XC5-48R-C	XC5-48T-C	XC5-48RT-C	28	20
	XC5-60R-E	XC5-60T-E	XC5-60RT-E	XC5-60R-C	XC5-60T-C	XC5-60RT-C	36	24
P N	-	XC5-24PT-E	-	-	XC5-24PT-C	-	14	10
	-	XC5-32PT-E	-	-	XC5-32PT-C	-	18	14
P	XC5-48PR-E	XC5-48PT-E	XC5-48PRT-E	XC5-48PR-C	XC5-48PT-C	XC5-48PRT-C	28	20
	XC5-60PR-E	XC5-60PT-E	XC5-60PRT-E	XC5-60PR-C	XC5-60PT-C	XC5-60PRT-C	36	24

● XCM Series Model List

Model							Input points (DC24V)	Output points (R, T)
AC Power Supply			DC Power Supply					
Relay output			Relay output	Transistor output	R/T Type			
N	-	XCM-24T-E	-	-	XCM-24T-C	-	14	10
P	-	XCM-32T-E	-	-	XCM-32T-C	-	18	14
N	-	XCM-48T-E	-	-	XCM-48T-C	-	28	20
P	-	XCM-24PT-E	-	-	XCM-24PT-C	-	14	10
N	-	XCM-32PT-E	-	-	XCM-32PT-C	-	18	14
P	-	XCM-48PT-E	-	-	XCM-48PT-C	-	28	20

● XCC series model list

Model							Input points (DC24V)	Output points (R, T)
AC power supply			DC power supply					
	Relay output	Transistor output	R/T output	Relay output	Transistor output	R/T output		
NPN	-	XCC-32T-E	-	-	XCC-32T-C	-	18	14
PNP	-	XCC-32PT-E	-	-	XCC-32PT-C	-	18	14

※1: XC1 can also have special 20 I/O model

1-2-2. Expansion's name principle and module list

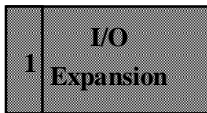

The I/O expansions' name principle:

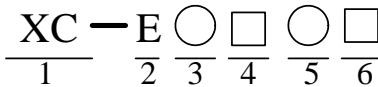

- 1: Series name XC
- 2: For Expansion E
- 3: Input points 8、16、32
- 4: For Input NPN Type: X
PNP Type: PX
- 5: Output points 8、16、32
- 6: For output YR: relay output
YT: transistor output

● I/O expansions list:

Model				I/O Points	Input points (DC24V)	Output points (R, T)	
	Input	Output					
		relay output	transistor output				
N	XC-E8X	-	-	8	8	-	
	-	XC-E8YR	XC-E8YT	8	-	8	
	-	XC-E8X8YR	XC-E8X8YT	16	8	8	
	P	XC-E16X	-	-	16	16	-
	N	-	XC-E16YR	XC-E16YT	16	-	16
	-	XC-E16X16YR	XC-E16X16YT	32	16	16	
	XC-E32X	-	-	32	32	-	
-	XC-E32YR	-	32	-	32		
P	XC-E8PX	-	-	8	8	-	
	-	XC-E8YR	XC-E8YT	8	-	8	
	-	XC-E8PX8YR	XC-E8PX8YT	16	8	8	
	N	XC-E16PX	-	-	16	16	-
	P	-	XC-E16YR	XC-E16YT	16	-	16
	-	XC-E16PX16YR	XC-E16PX16YT	32	16	16	
	XC-E32PX	-	-	32	32	-	
-	XC-E32YR	-	32	-	32		

2	Analogue & Temperature Expansion
---	---

Analogue、Temperature model name Principle:

XC — E 4AD 4DA 6PT 6TCA — P

① ② ③ ④ ⑤ ⑥

- | | |
|-----------------------|--|
| ① For Expansion | E |
| ② Analogue Input | 4AD: 4CH analogue input
8AD: 8CH analogue input |
| ③ Analogue Output | 2DA: 2CH analogue output
4DA: 4CH analogue output |
| ④ PT100 Temperature | 6PT: 6CH PT100 |
| ⑤ K type thermocouple | 6TCA: 6CH thermocouple input (V3.1 or above) |
| ⑥ P、I、D tune | P: with PID tune
Blank: without PID tune |

● Analogue、temperature modules list:

Model		Description
Analogue Input	XC-E8AD	8CH analogue input
	XC-E4AD	4CH analogue input
	XC-E4AD2DA	4CH analogue input, 2CH analogue output
Analogue Output	XC-E2DA	2CH analogue output
	XC-E4DA	4CH analogue output
Temperature Testing	XC-E6PT-P	6CH PT100 testing with PID tune
	XC-E6TCA-P	6CH K type thermocouple testing, each channel's PID tune separately
	XC-E3AD4PT2DA	3CH analogue input, 4CH PT100 testing, 2CH analogue output
	XC-E2AD2PT2DA	2CH analogue input, 2CH PT100 testing, 2CH analogue output

3	BD Card
----------	----------------

The BD card name principle:

XC — 4AD 6PT 6TC — P — BD

① ② ③ ④ ⑤

- | | |
|-----------------------|--|
| ① Analogue Input | 4AD: 4CH analogue input
8AD: 8CH analogue input |
| ② PT100 Temperature | 6PT: 6CH PT100 temperature Testing |
| ③ K Type thermocouple | 6TC: 6CH thermocouple testing |
| ④ P、I、D Tune | P: with PID tune
Blank: without PID tune |
| ⑤ For BD card | BD |

● BD card list

Model		Description
Temperature	XC-2AD2PT-BD	2CH analogue input, 2CH PT100 temperature testing
Analog	XC-2AD2DA-BD	2 CH analog input, 2 CH analog output
Communication	XC-COM-BD	RS-485/232 communication
SD card	XC-SD-BD	Install SD card and store the data in it
Ethernet	XC-TBOX-BD	To connect the Ethernet

1-3. Each Part's Description

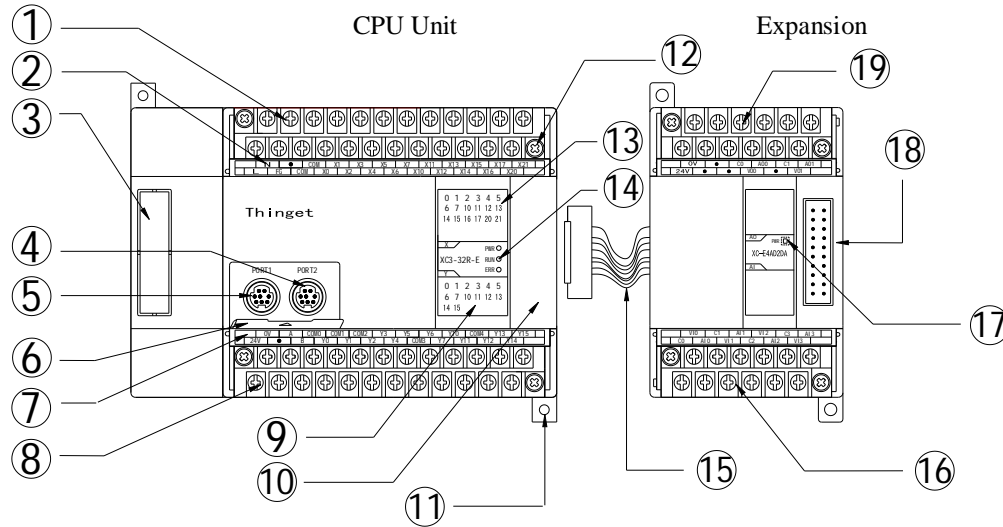

Each part's name is listed below:

Number	Name	Number	Name
1	Input & power supply terminals	11	Installation holes (2)
2	Input terminal label	12	Screws to install/remove the terminals
3	Port to install BD card	13	Input LED
4	COM2	14	Action LED: PWR (power); RUN (RUN); ERR (Error)
5	COM1	15	Expansion cable
6	Cover plate for COM port	16	Output terminals
7	Output terminal label	17	Action LED: PWR (power);
8	Output & 24V power terminals	18	Port to connect with expansion
9	Output LED	19	Input & power supply terminals
10	Port to connect with expansion		

2 The Specifications and Parameters of CPU

This chapter mainly tells the general specifications, performance, external dimension, terminals arrangement and communication interface of the CPU units. For the expansions, please refer to chapter 8.

2-1. Specifications and Parameters

2-2. External Dimension

2-3. Terminals Arrangement

2-4. Communication Interface

2-1. Specifications and Parameters

2-1-1. General Specifications

Items	Specifications
Isolate Voltage	Above DC 500V 2M ohm
Anti-noise	Noise voltage 1000Vp-p 1uS pulse per minute
Atmosphere	No erosive, flammable gas
Ambient Temperature	0°C~60°C
Ambient Humidity	5%~95% (no dew)
COM1 ^{※1}	RS-232, connect with the host machine, HMI to program or debug
COM2 ^{※2}	RS-232/RS-485, connect with net or intelligent instruments, inverters etc.
COM3 ^{※3}	RS-232C/RS-485 expanded by BD card
COM4 ^{※4}	CANBUS COM port
Installation	Use M3 screws or DIN to fix ^{※5}
Grounding	The third type grounding (do not grounding with the strong power system) ^{※6}

※1: All the CPU units have COM1, for program and communication;

※2: 10I/O、14I/O、16I/O CPU units don't have COM2;

※3: COM3 is the COM port from BD card (XC-COM-BD).

※4: COM4 is only equipped on XC series.

※5: The rail is DIN46277, width is 35mm.

※6: The grounding should be like type 1 and 2, not 3.

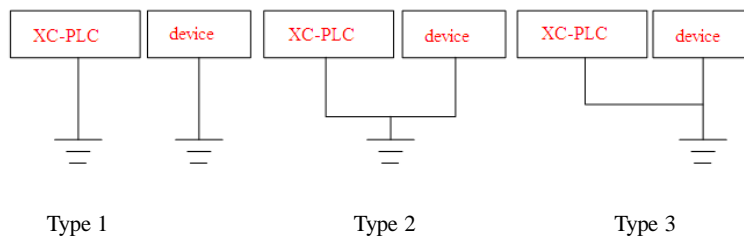

2-1-2. Performance and Specifications

XC1 series

Items		Specifications			
Program Executing Form		Loop scan form			
Program Form		Instruction、Ladder			
Dispose Speed		0.5 us			
Power Off Retentive		Use Flash ROM			
User's program space ^{※1}		32KB			
I/O points ^{※2}	Total I/O	10	16	24	32
	Input	5 X0~X4	8 X0~X7	12 X0~X13	16 X0~X17
	Output	5 Y0~Y4	8 Y0~Y7	12 Y0~Y13	16 Y0~Y17
Internal Coils (X) ^{※3}		X0~X77 (64)			
Internal Coils (Y) ^{※4}		Y0~Y77 (64)			
Internal Coils (M)		448	M0~M199		
			【M200~M319】 ^{※5}		
			For Special Use ^{※6} M8000~M8079		
			For Special Use ^{※6} M8120~M8139		
			For Special Use ^{※6} M8170~M8172		
			For Special Use ^{※6} M8238~M8242		
Flow (S)		32	S0~S31		
Timer (T)	Points	80	T0~T23: 100ms not accumulate		
			T100~T115: 100ms accumulate		
			T200~T223: 10ms not accumulate		
			T300~T307: 10ms accumulate		
			T400~T403: 1ms not accumulate		
			T500~T503: 1ms accumulate		
	Spec.	100ms timer: set time 0.1~3276.7sec. 10ms timer: set time 0.01~327.67sec. 1ms timer: set time 0.001~32.767sec.			
Counter (C)	Points	48	C0~C23: 16 bits sequential counter		
			C300~C315: 32 bits sequential/inverse counter		
			C600~C603: single phase high speed counter		
			C620~C621		
	C630~C631				
Spec.	16 bits counter: set value K0~32,767 32 bits counter: set value -2147483648~+2147483647				

Data Register (D)	288 words	D0~D99 【D100~D149】※5
		For Special Use※6 D8000~D8029
		For Special Use※6 D8060~D8079
		For Special Use※6 D8120~D8179
		For Special Use※6 D8240~D8249
		For Special Use※6 D8306~D8313
		For Special Use※6 D8460~D8469
Flash ROM Register (FD)	510 words	FD0~FD411
		For Special Use※6 FD8000~FD8011
		For Special Use※6 FD8202~FD8229
		For Special Use※6 FD8306~FD8315
		For Special Use※6 FD8323~FD8335
		For Special Use※6 FD8350~FD8384
High Speed Dispose Ability	No	
Password Protection	6 bits ASCII	
Self-diagnose Function	Power on self-check、 monitor timing、 grammar check	

XC2 Series

Items		Specifications					
Program Executing Form		Loop scan form					
Program Form		Instruction、Ladder					
Dispose Speed		0.5 us					
Power Off Retentive		Use Flash ROM					
User's program space ^{*1}		128K					
I/O points ^{*2}	Total I/O	14	16	24	32	48	60
	Input	8 X0~X7	8 X0~X7	14 X0~X15	18 X0~X21	28 X0~X33	36 X0~X43
	Output	6 Y0~Y5	8 Y0~Y7	10 Y0~Y11	14 Y0~Y15	20 Y0~Y23	24 Y0~Y27
Internal Coils (X) ^{*3}		X0~X1037 (544)					
Internal Coils (Y) ^{*4}		Y0~Y1037 (544)					
Internal Coils (M)		8768 points	M0~M2999				
			【M3000~M7999】 ^{*5} For Special Use ^{*6} M8000~M8767				
Flow (S)		1024 points	S0~S511 【S512~S1023】				
Timer	points	640 points	T0~T99: 100ms not accumulate				
			T100~T199: 100ms accumulate				
			T200~T299: 10ms not accumulate				
			T300~T399: 10ms accumulate				
			T400~T499: 1ms not accumulate				
			T500~T599: 1ms accumulate				
	T600~T639: 1ms precise time						
Spec.		100mS timer: set time 0.1~3276.7sec. 10mS timer: set time 0.01~327.67sec. 1mS timer: set time 0.001~32.767sec.					
Counter (C)	points	640 points	C0~C299: 16 bits sequential counter				
			C300~C598: 32 bits sequential/inverse counter				
			C600~C619: single phase high speed counter				
			C620~C629: dual-phase high speed counter				
	C630~C639: AB phase high speed counter						
Spec.		16 bits counter: set value K0~32,767 32 bits counter: set value -2147483648~+2147483647					
Data Register (D)		2612 Words	D0~D999				
			【D4000~D4999】 ^{*5} For Special Use ^{*6} D8000~D8511				

		For Special Use ^{※6} D8630~D8729
Flash ROM Register (FD)	512 words	FD0~FD127
		For Special Use ^{※6} FD8000~FD8383
High Speed Dispose Ability	High speed counter, pulse output, external interruption	
Password Protection	6 bits ASCII	
Self-diagnose Function	Power on self-check、 monitor the timer、 grammar check	

XC3 Series

Items		Specifications						
Program Executing Form		Loop scan form						
Program Form		Instruction、 Ladder						
Dispose Speed		0.5 us						
Power Off Retentive		Use Flash ROM and Li battery						
User's program space ^{※1}		128K						
I/O points ^{※2}	Total I/O	14	24	32	42	48	60	
	Input	8 X0~X7	14 X0~X15	18 X0~X21	24 X0~X27	28 X0~X33	36 X0~X43	
	Output	6 Y0~Y5	10 Y0~Y11	14 Y0~Y15	18 Y0~Y21	20 Y0~Y23	24 Y0~Y27	
Internal Coils (X) ^{※3}		X0~X1037 (544)						
Internal Coils (Y) ^{※4}		Y0~Y1037 (544)						
Internal Coils (M)		8768 points	M0~M2999				【M3000~M7999】 ^{※5}	
			For Special Use ^{※6} M8000~M8767					
Flow (S)		1024 points	S0~S511 【S512~S1023】					
Timer	points	640 points	T0~T99: 100ms not accumulate					
			T100~T199: 100ms accumulate					
T200~T299: 10ms not accumulate								
T300~T399: 10ms accumulate								
T400~T499: 1ms not accumulate								
T500~T599: 1ms accumulate								
Flow (S)	Spec.	640 points	T600~T639: 1ms precise time					
			100ms timer: set time 0.1~3276.7sec. 10ms timer: set time 0.01~327.67sec. 1ms timer: set time 0.001~32.767sec.					
Counter (C)	points	640 points	C0~C299: 16 bits sequential counter					
			C300~C598: 32 bits sequential/inverse counter					

		C600~C619: single phase high speed counter
		C620~C629: dual-phase high speed counter
		C630~C639: AB phase high speed counter
	Spec.	16 bits counter: set value K0~32,767 32 bits counter: set value -2147483648~+2147483647
Data Register (D)	9024 words	D0~D3999 【D4000~D7999】 ^{※5} For Special Use ^{※6} D8000~D9023
Flash ROM Register (FD)	4096 words	FD0~FD3071 For Special Use ^{※6} FD8000~FD9023
Expansion's Register (ED) ^{※7}	16384 words	ED0~ED16383
High Speed Dispose Ability	High speed counter, pulse output, external interruption	
Password Protection	6 bits ASCII	
Self-diagnose Function	Power on self-check、 monitor the timer、 grammar check	

XC5 Series

Items		Specifications			
Program Executing Form		Loop scan form			
Program Form		Instruction、 Ladder			
Dispose Speed		0.5 us			
Power Off Retentive		Use Flash ROM			
User's program space ^{※1}		96K			
I/O points ^{※2}	Total I/O	24	32	48	60
	Input	14 X0~X15	18 X0~X21	28 X0~X33	36 X0~X43
	Output	10 Y0~Y11	14 Y0~Y15	20 Y0~Y23	24 Y0~Y27
Internal Coils (X) ^{※3}		544 points: X0~X1037			
Internal Coils (Y) ^{※4}		544 points: Y0~Y1037			
Internal Coils (M)	8768 points	M0~M3999 【M4000~M7999】 ^{※5} For Special Use ^{※6} M8000~M8767			
Flow (S)	1024 points	S0~S511 【S512~S1023】			

Timer	points	640 points	T0~T99: 100ms not accumulate
			T100~T199: 100ms accumulate
			T200~T299: 10ms not accumulate
			T300~T399: 10ms accumulate
			T400~T499: 1ms not accumulate
			T500~T599: 1ms accumulate
	T600~T639: 1ms precise time		
Spec.	100ms timer: set time 0.1~3276.7sec. 10ms timer: set time 0.01~327.67sec. 1ms timer: set time 0.001~32.767sec.		
Counter (C)	points	640 points	C0~C299: 16 bits sequential counter
			C300~C598: 32 bits sequential/inverse counter
			C600~C619: single phase high speed counter
			C620~C629: dual-phase high speed counter
	C630~C639: AB phase high speed counter		
Spec.	16 bits counter: set value K0~32,767 32 bits counter: set value -2147483648~+2147483647		
Data Register (D)	9024 words	D0~D3999 【D4000~D4999】 ^{*5}	
		For Special Use ^{*6} D8000~D9023	
Flash ROM Register (FD)	8192 words	FD0~FD7167	
		For Special Use ^{*6} FD8000~FD9023	
Expand the internal registers (ED) ^{*7}	36864 words	ED0~ED36863	
High Speed Dispose Ability	High speed counter, pulse output, external interruption		
Password Protection	6 bits ASCII		
Self-diagnose Function	Power on self-check、monitor the timer、grammar check		

XCM Series

Items		Specifications		
Program Executing Form		Loop scan form		
Program Form		Instruction, Ladder		
Dispose Speed		0.5 us		
Power Off Retentive		Use Flash ROM and Li battery		
User's program space ^{*1}		160KB		
I/O points	Total I/O	24	32	60

※2	Input	14 X0~X015	18 X0~X021	36 X0~X43
	Output	10 Y0~Y011	14 Y0~Y015	20 Y0~Y27
Internal Coils (X) ※3		X0~X1037 (Total 544)		
Internal Coils (Y) ※4		Y0~Y1037 (Total 544)		
Internal Coils (M)		8768 points	M0~M2999 【M3000~M7999】 ※5 For Special Use ※6 M8000~M8767	
Flow (S)		1024 points	S0~S511 【S512~S1023】	
Timer	points	640 points	T0~T99: 100ms not accumulate	
			T100~T199: 100ms accumulate	
			T200~T299: 10ms not accumulate	
			T300~T399: 10ms accumulate	
			T400~T499: 1ms not accumulate	
			T500~T599: 1ms accumulate	
	Spec.	100ms timer: set time 0.1~3276.7sec. 10ms timer: set time 0.01~327.67sec. 1ms timer: set time 0.001~32.767sec.		
Counter (C)	points	640 points	C0~C299: 16 bits sequential counter	
			C300~C598: 32 bits sequential/inverse counter	
			C600~C619: single phase high speed counter	
			C620~C629: dual-phase high speed counter	
			C630~C639: AB phase high speed counter	
	Spec.	16 bits counter: set value K0~32,767 32 bits counter: set value -2147483648~+2147483647		
Data Register (D)		5024 words	D0~D2999 【D4000~D4999】 ※5 For Special Use ※6 D8000~D9023	
FlashROM register (FD)		1996 words	FD0~FD1535 For Special Use ※6 FD8000~FD8349 For Special Use ※6 FD8890~FD8999	
Expand the internal registers (ED) ※7		36864 words	ED0~ED36863	
High Speed Dispose Ability		High speed counter, pulse output, external interruption		
Password Protection		6 bits ASCII		
Self-diagnose Function		Power on self-check、 monitor the timer、 grammar check		

XCC series

Items		Specifications	
Program Executing Form		Loop scan form	
Program Form		Instruction、Ladder	
Dispose Speed		0.5 us	
Power Off Retentive		Use Flash ROM and Li battery	
User's program space ^{※1}		256KB	
I/O points ^{※2}	Total I/O	32	
	Input	18	
	Output	14	
Internal Coils (X) ^{※3}		X0~X1037 (Total 544)	
Internal Coils (Y) ^{※4}		Y0~Y1037 (Total 544)	
Internal Coils (M)	8768 points	M0~M2999	
		【M3000~M7999】 ^{※5} For Special Use ^{※6} M8000~M8767	
Flow (S)	1024 points	S0~S511 【S512~S1023】	
Timer	points	640 points	T0~T99: 100ms not accumulate
			T100~T199: 100ms accumulate
			T200~T299: 10ms not accumulate
			T300~T399: 10ms accumulate
			T400~T499: 1ms not accumulate
			T500~T599: 1ms accumulate
	T600~T639: 1ms precise time		
Spec.	100ms timer: set time 0.1~3276.7sec. 10ms timer: set time 0.01~327.67sec. 1ms timer: set time 0.001~32.767sec.		
Counter (C)	points	640 points	C0~C299: 16 bits sequential counter
			C300~C598: 32 bits sequential/inverse counter
			C600~C619: single phase high speed counter
			C620~C629: dual-phase high speed counter
			C630~C639: AB phase high speed counter
	Spec.	16 bits counter: set value K0~32,767 32 bits counter: set value -2147483648~+2147483647	
Data Register (D)	9024 words	D0~D3999	
		【D4000~D7999】 ^{※5} For Special Use ^{※6} D8000~D9023	
FlashROM register (FD)	2048 words	FD0~FD1023	

		For Special Use ^{※6} FD8000~FD9023
Expand the internal registers (ED) ^{※7}	36864 words	ED0~ED36863
High Speed Dispose Ability	High speed counter, pulse output, external interruption	
Password Protection	6 bits ASCII	
Self-diagnose Function	Power on self-check、 monitor the timer、 grammar check	

- ※1: The user's program space: refer to the maximum program space when download secretly.
- ※2: I/O points: refer to the terminal number that users can connect from outside
- ※3: X: refer to the internal input relays, users can use middle relay when exceed the Input points
- ※4: Y: refer to the internal output relays, users can use middle relay when the Output points exceed
- ※5: 【】 Sign: The default power off retentive area, this area can be changed
- ※6: For special use: refer to the special usage registers that are occupied by the system, can't be applied for other usage. For details, please refer to Appendix 1;
- ※7: Only the hardware with 3.0 or above version of the CPU units has internal expansion register ED;
- ※8: XC3-14 hardware version 3.2: the ED is 0.
- ※9: Input and output coil no. is octal, other coil and register are decimal.
- ※10: The I/O which is not connected to other device can be used to internal coil.
- ※11: Flash ROM register doesn't have to set power loss retentive, the data will not lose when power is off.

2-2. External Dimension

Graph 1

(Unit: mm)

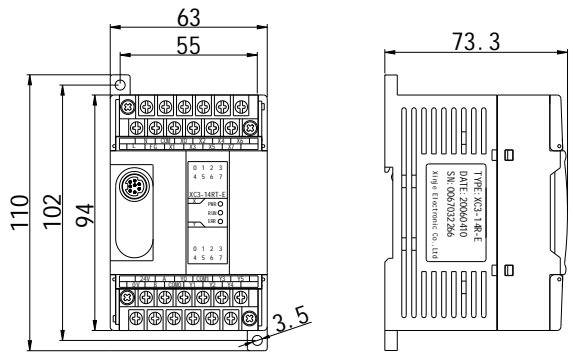

Suitable Model

Series	I/O
XC1	10 and 16
XC2	14 and 16
XC3	14

Graph 2

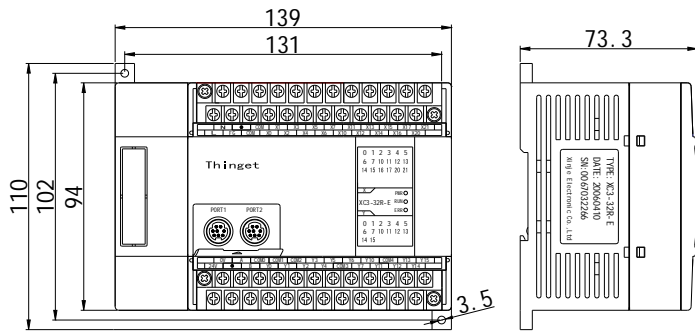

(Unit: mm)

Suitable Model

Series	I/O
XC1	24 and 32
XC2	24 and 32
XC3	24 and 32
XC5	24 and 32
XCM	24 and 32
XCC	32

Graph 3

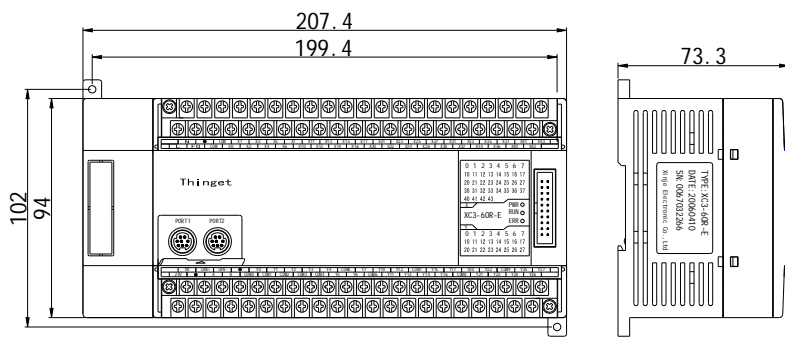

(Unit: mm)

Suitable Model

Series	I/O
XC2	48 and 60
XC3	48 and 60
XC5	48 and 60
XCM	60

Graph 4

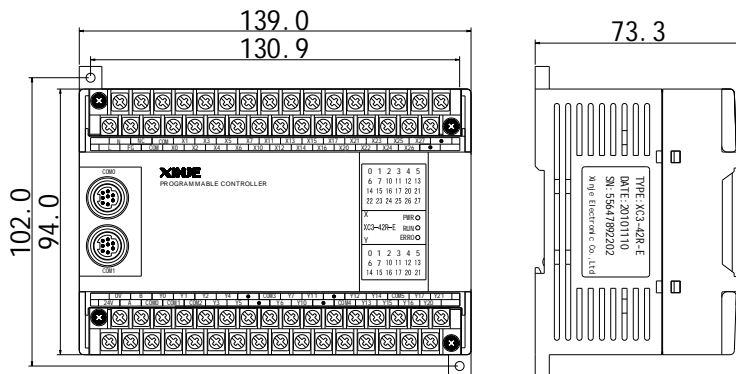

Unit: mm

Suitable model

Series	I/O
XC3	42

2-3. Terminals Arrangement

● Graph A

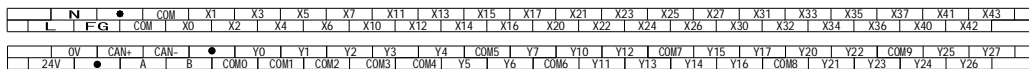

● Graph B

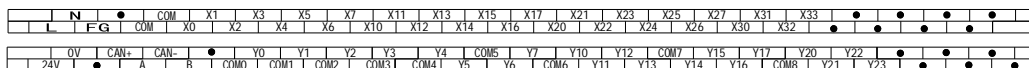

● Graph C

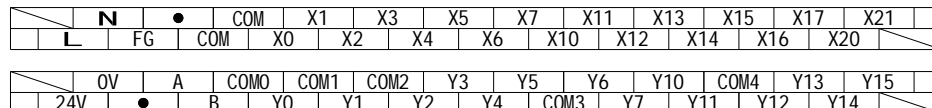

● Graph D

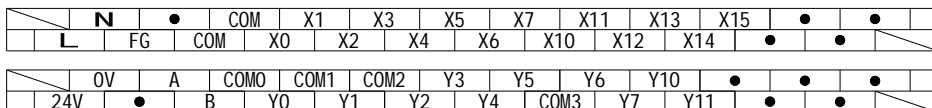

● Graph E

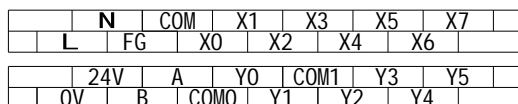

● Graph F

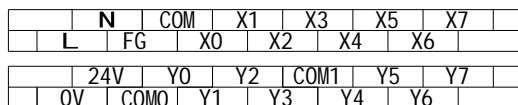

● Graph G

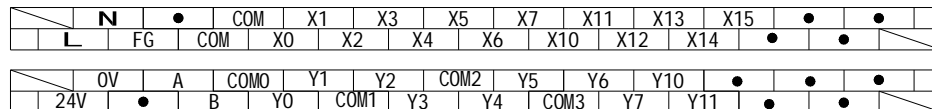

● Graph H

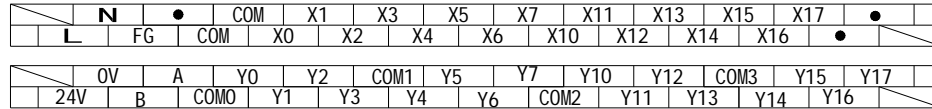

● Graph I

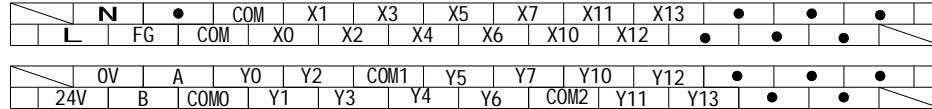

● Graph J

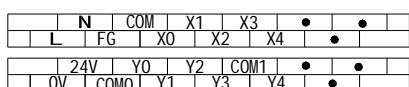

● Graph K

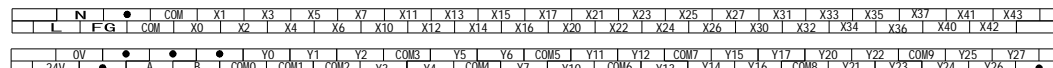

● Graph L

	N	NC	COM	X1	X3	X5	X7	X11	X13	X15	X17	X21	X23	X25	X27	●	
L	FG	COM	X0	X2	X4	X6	X10	X12	X14	X16	X20	X22	X24	X26	●		
	OV	A	COMO	COM1	COM2	Y3	Y5	Y6	Y10	●	COM4	Y13	Y15	COM5	Y17	Y21	
24V	●	B	Y0	Y1	Y2	Y4	COM3	Y7	Y11	●	Y12	Y14	●	Y16	Y20		

● Graph M

	N	●	COM	X1	X3	X5	X7	X11	X13	X15	X17	X21					
L	FG	COM	X0	X2	X4	X6	X10	X12	X14	X16	X20						
	OV	A	COMO	Y1	Y2	COM2	Y5	Y6	Y10	COM4	Y13	Y15					
24V	●	B	Y0	COM1	Y3	Y4	COM3	Y7	Y11	Y12	Y14						

● Graph N

	N	●	COM	X1	X3	X5	X7	X11	X13	X15	●	●	●				
L	FG	COM	X0	X2	X4	X6	X10	X12	X14	●	●	●					
	OV	A	COMO	COM1	Y2	Y3	Y5	Y6	Y10	●	●	●					
24V	●	B	Y0	Y1	COM2	Y4	COM3	Y7	Y11	●	●	●					

● Graph O

	N	●	COM	X1	X3	X5	X7	X11	X13	X15	X17	X21					
L	FG	COM	X0	X2	X4	X6	X10	X12	X14	X16	X20						
	OV	A	COMO	COM1	Y2	Y3	Y5	Y6	Y10	COM4	Y13	Y15					
24V	●	B	Y0	Y1	COM2	Y4	COM3	Y7	Y11	Y12	Y14						

● Graph P

	N	●	COM	X1	X3	X5	X7	X11	X13	X15	X17	X21					
L	FG	COM	X0	X2	X4	X6	X10	X12	X14	X16	X20						
	OV	A	COMO	COM1	Y2	Y3	Y5	Y6	Y10	COM4	Y13	Y15					
24V	●	B	Y0	Y1	COM2	Y4	COM3	Y7	Y11	Y12	Y14						

The Graph to the model:

Graph	Suitable model	I/O
A	XC2-60、XC3- 60、XC5- 60	36/24
B	XC2-48、XC3- 48、XC5- 48	28/20
C	XC2-32、XC3- 32、XC5- 32	18/14
D	XC2-24、XC3- 24	14/10
E	XC2-14、XC3- 14	8/6
F	XC1- 16、XC2-16	8/8
G	XC5- 24、XCM-24T4	14/10
H	XC1- 32	16/16
I	XC1- 24	12/12
J	XC1-10	5/5
K	XCM-60	36/24
L	XC3-42	24/18
M	XCM-32T4	18/14
N	XCM-24T3	14/10
O	XCM-32T3	18/14
P	XCC-32	18/14

Note: for XC5-32, the com terminal of Y2, Y3 is COM1.

2-4. Communication Ports

COM1

Pins of COM1:

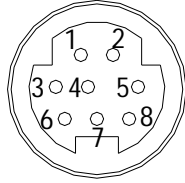

- 2: PRG
- 4: RxD
- 5: TxD
- 6: VCC
- 8: GND

Mini Din 8 female

COM2

Pins of COM2*1:

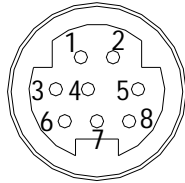

- 4: RxD
- 5: TxD
- 8: GND

Mini Din 8 female

Program Cable



*1: in the graph we show only RS232 of COM2, we extend RS485 (A, B) to the terminals), so we here don't list them out.

3 System Structure

As the controller, XC series PLC can connect with many types of peripheral equipments, expansions etc. In this chapter, it introduces the peripheral devices, the connection principle of CPU with expansions, installation, calculate the I/O points, input/output ID etc.

For the introduction of expansions, please refer to chapter 8;

3-1. System Structure

3-2. Peripheral Devices

3-3. Combination Principle

3-4. Expansion's ID assignment

3-5. Install the Products

3-1. System Structure

In the below Graph, we show the common system structure according to XC series PLC basic configuration. Via this graph, we could know the basic connection among PLC and peripheral equipments; also classic applications of PLC's each COM port, connection and expansion.

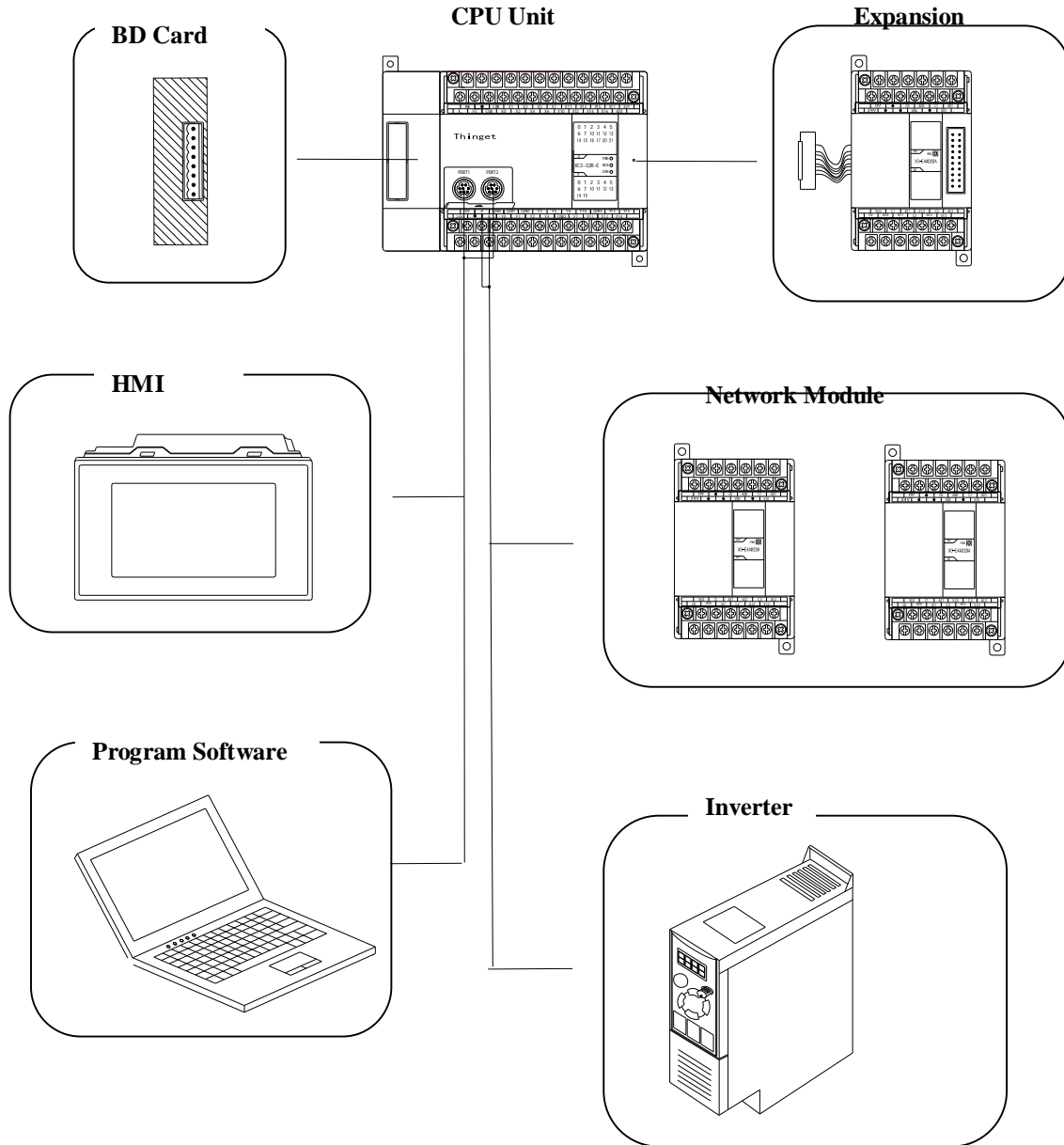

※1: In the above graph, the communication devices connected to the COM port are only samples for your reference. Each COM port can connect with many devices in real applications.

3-2-2. Human Machine Interface (HMI)

The HMI link PLC to the operators. The HMI can send the commands from operators to PLC, and then PLC executes the commands.

XC series PLC support diverse brands of HMI; the connection is based on the communication protocol. Generally communicate via Modbus protocol, the detailed parameters setting depends on the HMI.

The Xinje HMI can work with PLC directly (the communication parameters are set in accordance already). Presently Xinje HMI has TG, TH, TP, OP, MP series.

TH, TP Series HMI

- Size: 4.3"、4.7"、5.7"、7"、8"、10.1"、10.4"
- Display: 65536, 256 true color TFT, blue LCD
- Operation: Touch Screen
- Interface: RS232、RS422、RS485, USB, RJ45
- Communication: work with many PLC brands, inverters, instruments etc.
 - Communicate with Xinje Inverters
 - Driver panel printer directly
 - Dual COM ports, work with two different devices separately
 - Support free format protocol, the user can write the driver program freely
- Recipe
- Advanced Function
- RTC: Real Time Clock
- Password: nine-level setting

OP Series Operation Panels

- Size 3.7"、5.7"
- Display Blue LCD、256 true color
- Buttons Nr. 7、20、42
- Interface RS232、RS485
- Communication: work with many PLC brands.
 - Communicate with Xinje Inverters
- RTC: real time clock

MP Series Operation Panels with Touch Function

- Size 3.7"、7"
- Display 256 true color、blue LCD
- Buttons Nr.: 26、42, the LCD is touch screen
- Interface: RS232、RS485
- Communication: work with many PLC brands.
Communicate with Xinje Inverters
- RTC: Real Time Clock

3-2-3. Network Module

PLC can build Modbus network, the special models can build CANBUS network.
If the basic units configure with the special network module, they can connect to GPRS network, Ether net etc.

1 G-BOX

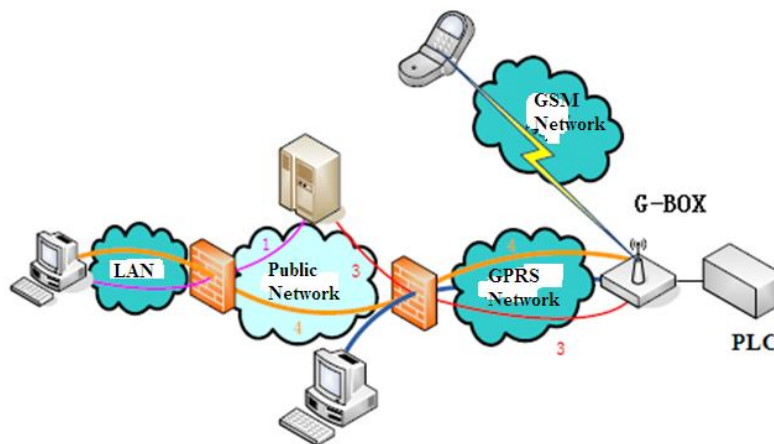

- Transfer data wirelessly, open and transparent;
- Remote program and debug PLC, realize upload/download PLC;
- Integral data transfer terminal of TCP/IP protocol pallet, support TCP, UDP, DNS, PPP etc.
- Standard industrial interface (RS-232 or RS-485)
- Support long time online mode, equipped re-dial and heart-beat functions;
- Support SMS to control PLC
- Support local configuration
- Support GPRS network and GSM network

- Suitable for distributed system and remote control applications.

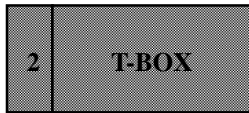

As industrial Ether Net module, T-BOX supports Modbus-RTU devices; the design is applied to industrial Ether net control system.

- Remote integral maintenance and diagnose of PLC program on IP devices;
- Remote integral monitor of PLC program on IP devices;
- The traditional Modbus communication is one master, multi-slave form. The communication speed is slow. Via the connection by T-Box, users can realize the data exchange among master PLC and each subsidiary PLCs.

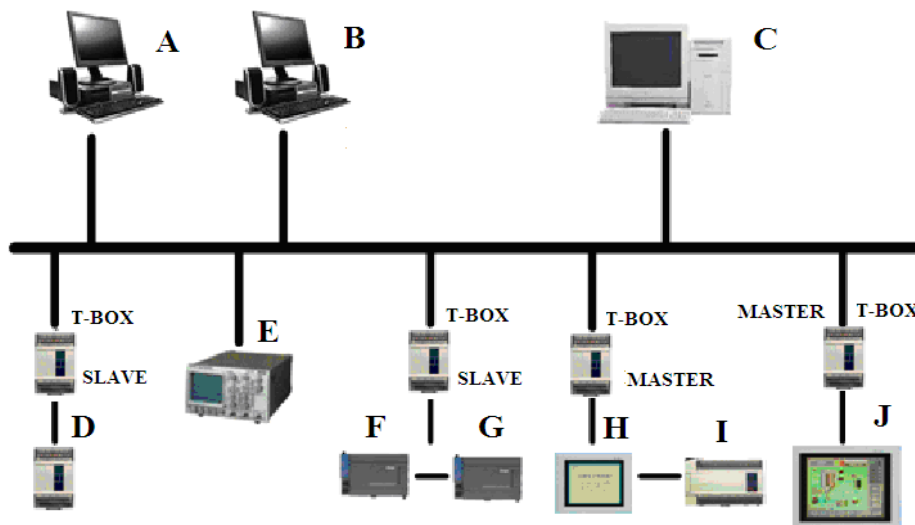

- Realize flexible distributing automation structure, simplify the system management
- Realize Ether net visit via RJ45 interface, the communication is based on standard TCP/IP protocol
- Realize remote program, monitor, diagnose via industrial Ether net, save great time and cost;
- Store and operate data information via Ether net, build base to simplify the data disposal and file
- Enable the communication between Ether net and automation equipments, enable these devices to be used in complicated systems;
- High performance-price ratio, link the ether net to all the automation devices and levels in a simple form.
- Easy to maintenance, support simple diagnose function

3-3. Configuration Principle

About COM port

- XC series PLC (CPU units) are usually equipped with COM1 and COM2.
- Normally, both COM ports can be used to program, download, communication; but please make sure not change the parameters on two COM ports at one time, or the COM ports can't be used to program and download anymore;
- COM2 is equipped with RS232 and RS485. But COM2 can't use these two modes at one time; that's to say, COM2 can only be applied to one interface mode;

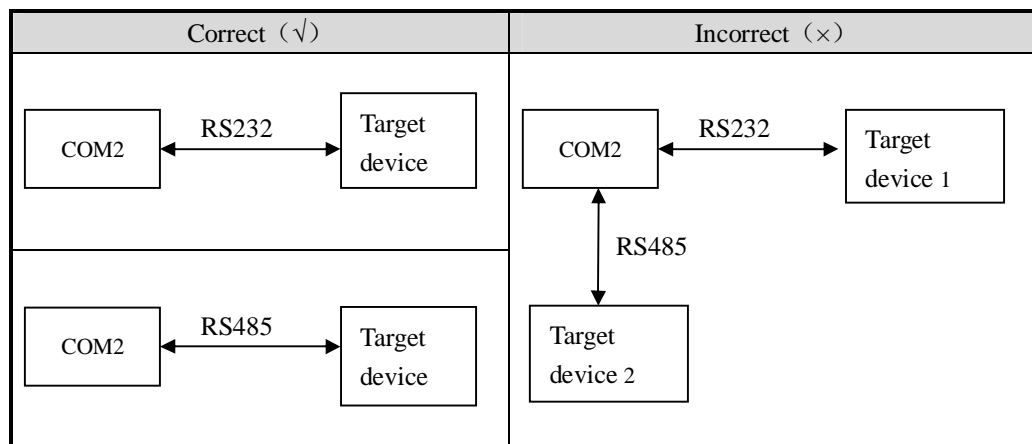

About Expansion Devices

- Generally, one CPU unit can work with different types of expansions; can expand digital I/O, analog I/O, temperature control etc.
- One CPU unit can work with 7 expansions and an extra BD card.

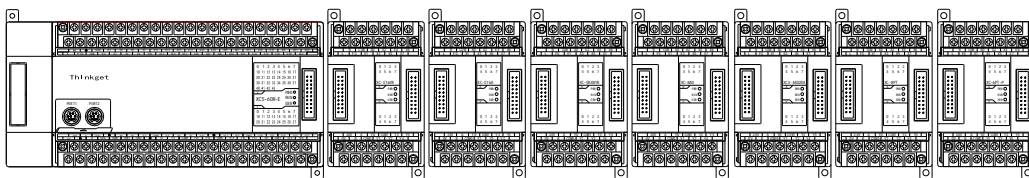

- After connect the CPU unit with the expansion, if the "PWR" LED on expansion ON, then the expansion can work properly; after installing the BD card to CPU unit, users need to configure it before using;

How to calculate the I/O

- After connect with the expansions, the total I/O points=I/O on basic unit + I/O on expansions.
- Digital I/O is octal
- Analog I/O is Decimal
- After expansion, the total I/O can reach 284 points

How to Calculate the I/O Points

Basic Unit XC3-32R-E (18I/14O) connects with five expansions: XC-E8X8Y, XC-E16X, XC-E32Y, XC-E2AD, XC-E4DA. Then the total I/O points should be:

Input Points: $18 + 8 + 16 = 42$

Output points: $14 + 8 + 32 = 54$

Total points: Input+ Output = $42+54=96$

3-4. ID Assignment of Expansions

Expansion Position	Type	ID (As Register)	Maximum points/channels
Position 1#	Digital Input X	X100~X137	32 points
	Digital Output Y	Y100~Y137	32 points
	Analog Input ID	ID100~ID131	16 channels
	Analog Output QD	QD100~QD131	16 channels
	Module's Value D	D8250~D8259	-
Position 2#	Digital Input X	X200~X237	32 points
	Digital Output Y	Y200~Y237	32 points
	Analog Input ID	ID200~ID231	16 channels
	Analog Output QD	QD200~QD231	16 channels
	Module's Value D	D8260~D8269	-
Position 3#	Digital Input X	X300~X337	32 points
	Digital Output Y	Y300~Y337	32 points
	Analog Input ID	ID300~ID331	16 channels
	Analog Output QD	QD300~QD331	16 channels
	Module's Value D	D8270~D8279	-
Position 4#	Digital Input X	X400~X437	32 points
	Digital Output Y	Y400~Y437	32 points
	Analog Input ID	ID400~ID431	16 channels
	Analog Output QD	QD400~QD431	16 channels
	Module's Value D	D8280~D8289	-
Position 5#	Digital Input X	X500~X537	32 points
	Digital Output Y	Y500~Y537	32 points
	Analog Input ID	ID500~ID531	16 channels
	Analog Output QD	QD500~QD531	16 channels
	Module's Value D	D8290~D8299	-
Position 6#	Digital Input X	X600~X637	32 points
	Digital Output Y	Y600~Y637	32 points
	Analog Input ID	ID600~ID631	16 channels
	Analog Output QD	QD600~QD631	16 channels
	Module's Value D	D8300~D8309	-
Position 7#	Digital Input X	X700~X737	32 points
	Digital Output Y	Y700~Y737	32 points
	Analog Input ID	ID700~ID731	16 channels
	Analog Output QD	QD700~QD731	16 channels
	Module's Value D	D8310~D8319	-
BD Card	Digital Input X	X1000~X1037	32 points
	Digital Output Y	Y1000~Y1037	32 points
	Analog Input ID	ID1000~ID1031	16 channels

	Analog Output QD	QD1000~QD1031	16 channels
	Module's Value D	D8320~D8329	-

3-5. Install the Products

Installation Position

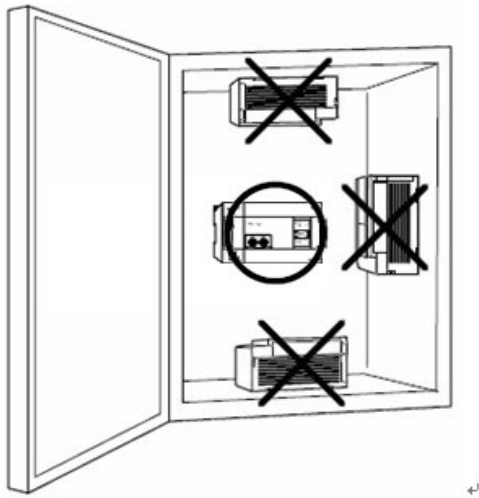

Installation Method

Use DIN or screws to install the CPU units and expansions.

Use DIN46277

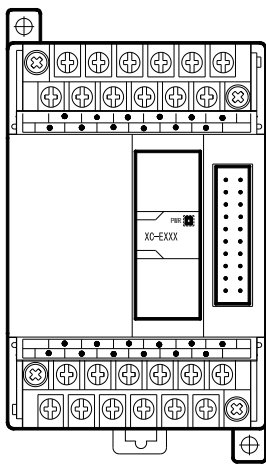

- Directly install by screws

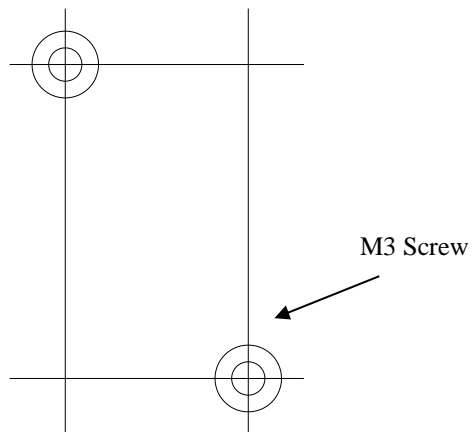

DIN installation

3	Installation Environment
----------	---------------------------------

Please install the products according to chapter 2-1-1

4

Power Supply Specification and Wiring Method

In this chapter, we tell the structure, specification and external wiring of XC series PLC. The wiring method differs according to different models. The mainly difference is the wiring terminals. For each model's terminal arrangement, please refer to chapter 2-3.

4-1. Power Supply Specification

4-2. AC Power, DC Input Type

4-1. Power Supply Specifications

The power supply specifications of XC series PLC are listed below:

1	AC Power Supply
---	-----------------

Items	Content
Rated Voltage	AC100V~240V
Allow Voltage Range	AC90V~265V
Rated Frequency	50/60Hz
Allow momentary power off time	Interruption Time \leq 0.5 AC cycle, interval \geq 1sec
Impulse Current	Below 40A 5mS/AC100V below 60A 5mS/AC200V
Maximum Power Consumption	12W
Power Supply for Sensor	24VDC \pm 10% maximum 400mA

※1: Please use the wire cable thicker than 2mm², to avoid the decrease of voltage;

※2: Even happens the 10ms power off, the PLC can keep working. But when power off for long time or voltage abnormal decrease, the PLC will stop working, output will be OFF. When power supply recover, the PLC will RUN automatically.

※3: The grounding terminals on basic units and expansions connect together and use the third type grounding.

2	DC Power Supply Type
---	----------------------

Items	Content
Rated Voltage	DC24V
Allow Voltage Range	DC21.6V~26.4V
Input Current (Only for basic unit)	120mA DC24V
Allow momentary power off time	10mS DC24V
Impulse Current	10A DC26.4V
Maximum Power Consumption	12W
Power Supply for Sensor	24VDC \pm 10% maximum 400mA

4-2. AC Power DC Input Type

1 Connection

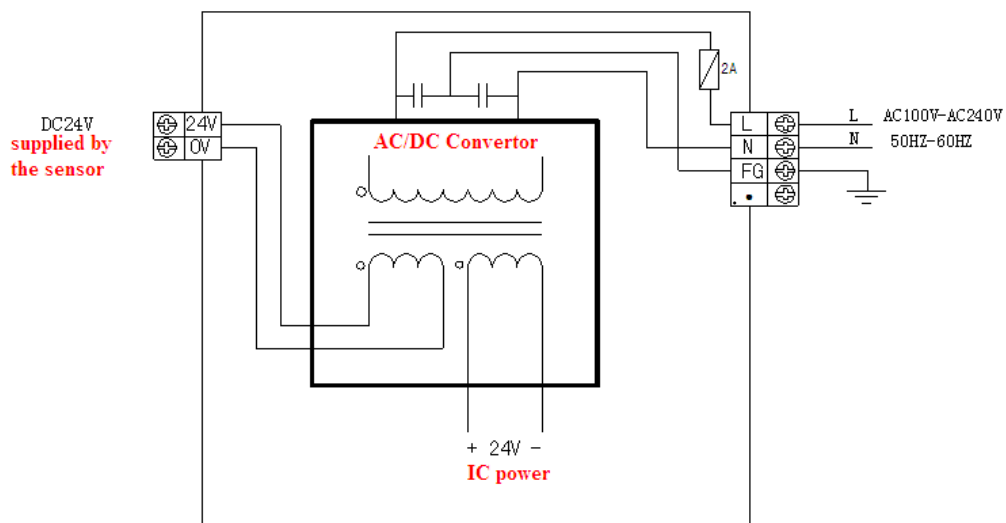

※1: Connect the power supply to L, N terminals

※2: 24V、COM can supply 400mA/DC24V power supply. Do not give these two terminals power supply

※3: terminals are blank terminals, please do not wire them or use them as middle relays

※4: Please connect the terminals on basic units and expansions together

5 Input Specifications and Wiring Methods

In this chapter, we tell the input specification and external wiring methods of XC series PLC. The connection method differs according to different model; the main reason is the terminal's position. For each model's terminal arrangement, please refer to chapter 2-3.

5-1. Input Specification

5-2. DC Input Signal (AC power supply type)

5-3. High Speed counter input

5-1. Input Specification

1 Basic Units

Input signal's voltage	DC24V±10%
Input signal's current	7mA/DC24V
Input ON current	Up to 4.5mA
Input OFF current	Low than 1.5mA
Input response time	About 10ms
Input signal's format	Contact input or NPN open collector transistor
Circuit insulation	Photo-electricity coupling insulation
Input action's display	LED light when input ON

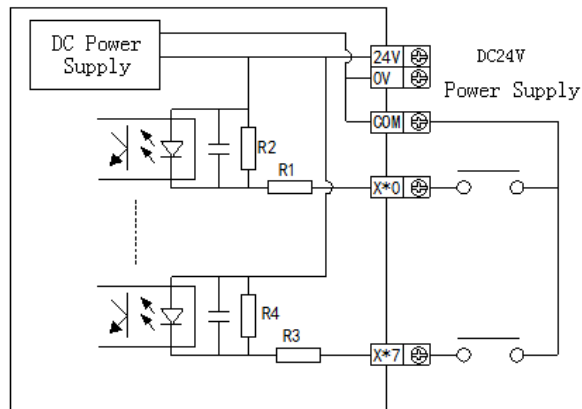

2 Expansion Modules

Input signal's voltage	DC24V±10%
Input signal's current	7mA/DC24V
Input ON current	Up to 4.5mA
Input OFF current	Low than 1.5mA
Input response time	About 10ms
Input signal's format	Contact input or NPN open collector transistor
Circuit insulation	Photo-electricity coupling insulation
Input action's display	LED light when input ON

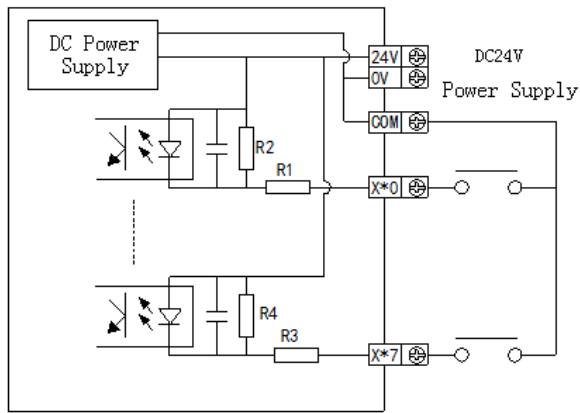

5-2. DC Input Signal (AC Power Supply Type)

1	DC Input Signal
---	--------------------

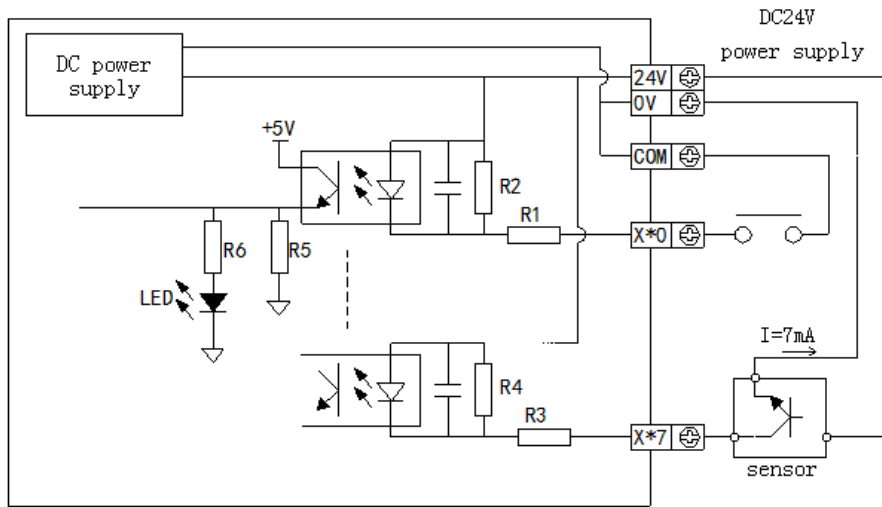

- **Input terminal**
When connect input terminal and **COM** terminal with contacts without voltage or NPN open collector transistor, if input is ON, LED lamp lights, which indicates input. There are many **COM** terminals to connect in PLC.
- **Input circuit**
Use optical coupling instrument to insulate the input once circuit and twice circuit, There's a C-R filter in the twice circuit. It is set to avoid wrong operation caused by vibration of input contacts or noise along with input signal. As the preceding reason, for the changing of input ON→OFF, OFF→ON, in PLC, the response time delays about 10ms. There's a digital filter inside X000~X015. This kind of filter can vary from 0~15ms according to the special register (FD8000).
- **Input sensitive**
The PLC's input current is DC24V 7mA, but to be safe, it needs current up to 3.5mA when it's ON, lower than 1.5mA when it's OFF.

2	External circuit used by sensors
----------	---

XC series PLC input power is from its interior 24V power, if the exterior power drives photo-electricity sensor etc., this exterior power should be DC24V±4V. Please use NPN open collector type for sensor output transistor

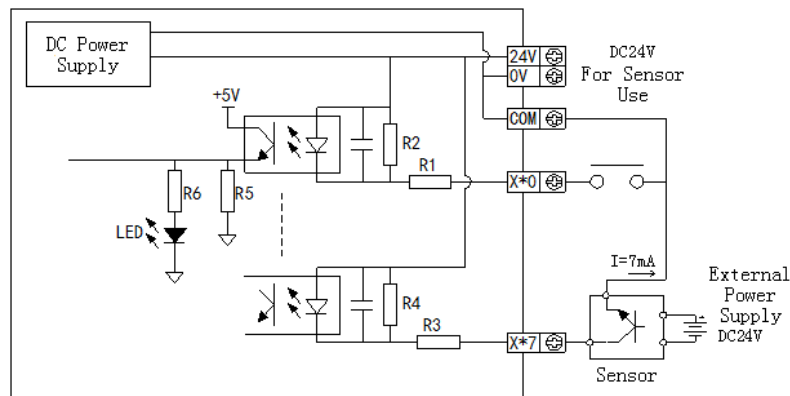

3	Input Wiring
----------	---------------------

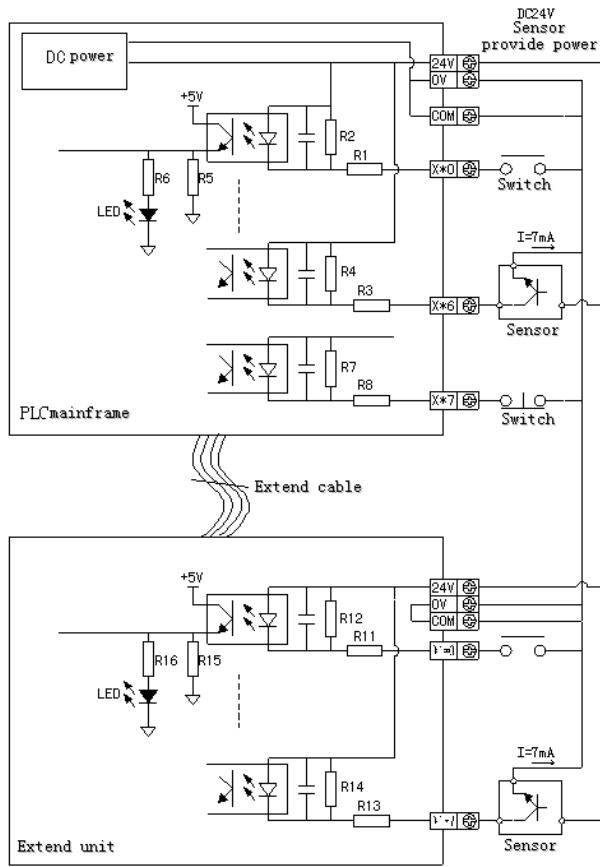

5-3. High Speed Counter Input

XC series PLC support high speed count function which is independent with the scan cycle. Via choosing different counter, testing the high speed input signal comes from sensor and rotary encoder. The highest testing frequency can reach 80 KHz.

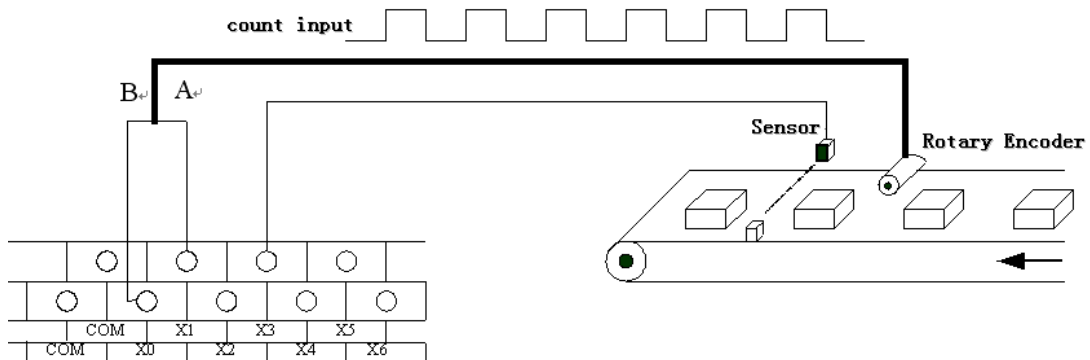

5-3-1. Count Mode

XC series HSC function has three count modes: Increment mode, Pulse+Direction mode, AB-phase mode;

1 Increment Mode

Under this mode, input the pulse signal, the count value increase with every rising edge of pulse signal;

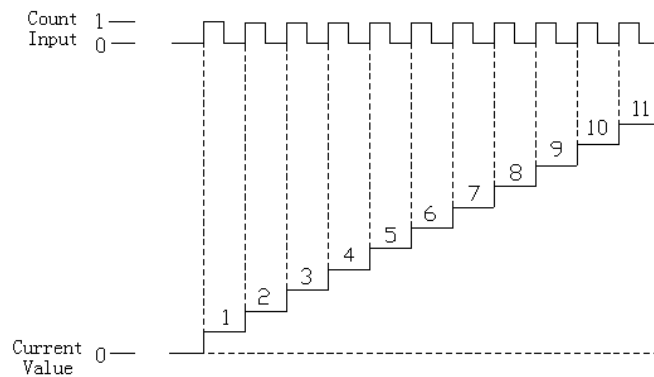

2 Pulse+Direction Mode

Under this mode, input the pulse signal and direction signal together. The count value increase or

decrease according to the direction status. If the count direction is OFF, do increment count with the input's rising edge; if the count direction is ON, do decrement count with the input's rising edge;

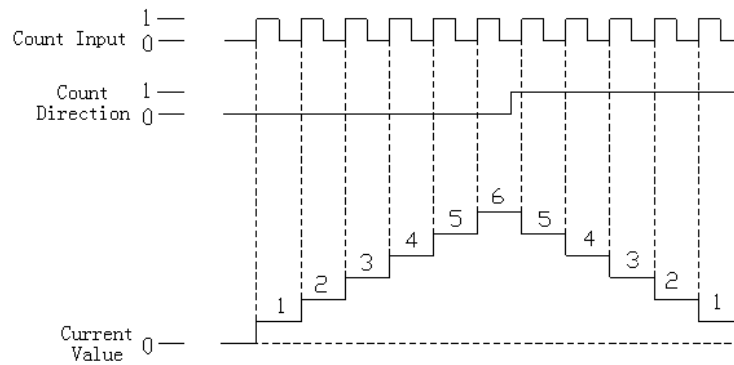

3 AB Phase Mode

Under this mode, the HSC value increase or decrease according to the two difference signal (A phase or B phase). According to the times number, we have also one-time frequency mode and four-time frequency mode. The default mode is four-time frequency mode.

One-time Frequency Mode

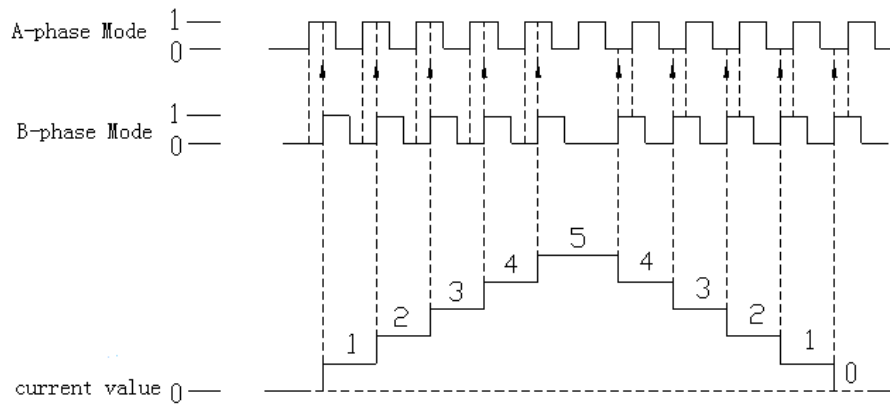

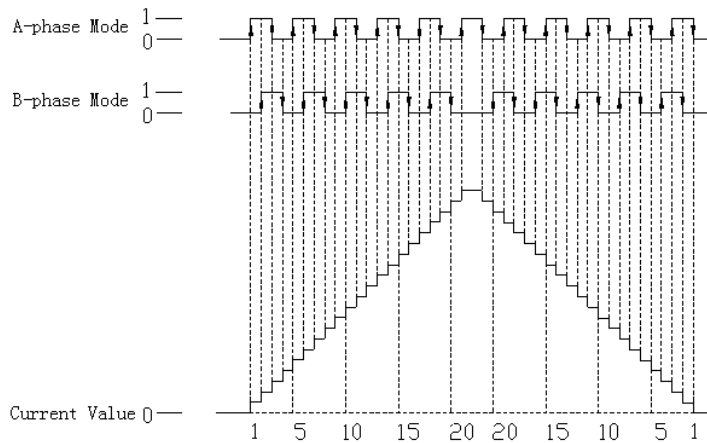
Four-time Frequency Mode**5-3-2. High Speed Count Range**

The HSC's count range is: K-2,147,483,648 ~ K+2,147,483,647. If the count value exceeds this range, up-flow or down-flow appears;

The up-flow means: the count value jumps from K+2,147,483,647 to be K-2,147,483,648 then continue to count; the down-flow means: the count value jumps from K-2,147,483,648 to be K+2,147,483,647, then continue to count;

5-3-3. The Input Wiring Of HSC

For the input wiring of pulse, it differs according to PLC's model and counter's model. Below, we show several typical wiring methods (take XC3-48 PLC as the example):

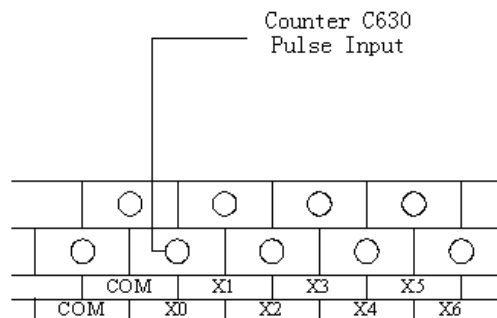
1 Increment Mode

2 Pulse+Direction Mode

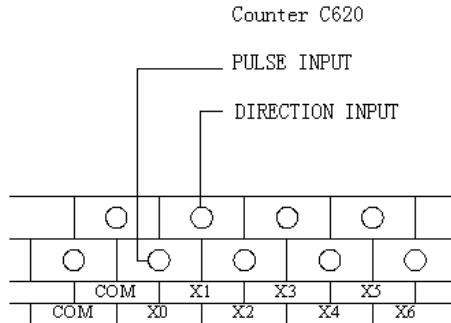

3 AB Phase Mode

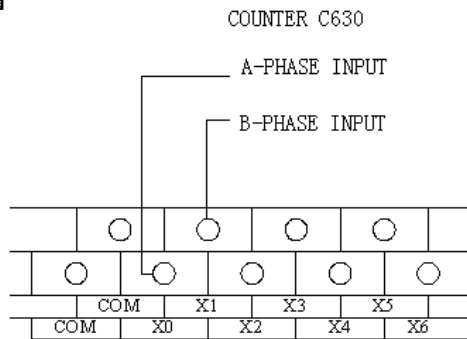

5-3-3. Input Terminals Assignment

1、 High Speed counters Assignment of XC series PLC:

PLC model	High speed counter channels		
	Incremental mode	Pulse+direction mode	AB phase mode
XC2 series	5	2	2
XC3 series	14	4	2
	24/32/42	6	3
	48/60	4	2
XC5 series	24/32	2	1
	48/60	6	3
XCM series	24/32 T4	2	1
	32 T3	4	2
	60	4	0

XCC series	32	5	0	5
------------	----	---	---	---

2、Input Terminals of HSC:

Each letter's description:

U	Dir	A	B
Counter's pulse input	Counter's direction judgment (OFF: increment counter, ON: decrement counter)	A phase input	B phase input

Normally, X0, X1 terminals' input frequency can reach 80KHz under single-phase and AB phase mode; the other terminal's input frequency can reach 10KHz under single-phase mode and 5KHz under AB phase mode. If X input terminals are not used as high speed input port, they can be used as common input terminals. The detailed port assignment is shown below:

XC2 series PLC																		
	Increment Mode										Pulse + direction mode					AB phase mode		
	C600	C602	C604	C606	C608	C610	C612	C614	C616	C618	C620	C622	C624	C626	C628	C630	C632	C634
Highest frequency	80K	80K	10K	10K	10K						80K	10K				80K	5K	
4 times frequency																√		
Counter interruption	√	√	√	√	√						√					√		
X000	U										U					A		
X001		U									Dir					B		
X002																		
X003			U									U					A	
X004												Dir					B	
X005																		
X006				U														
X007					U													
X010																		
X011																		
X012																		

Note:

- XC2-16: C600, C602, C620, C630 max frequency is 10KHz;
- XC2-14: max frequency is 10 KHz.

XC3-14 PLC																			
	Increment Mode										Pulse + direction mode				AB phase mode				
	C600	C602	C604	C606	C608	C610	C612	C614	C616	C618	C620	C622	C624	C626	C628	C630	C632	C634	
*Max. Frequency	10K	10K	10K	10K							10K	10K					5K	5K	
4 times frequency																		√	
Counter's interruption	√	√	√	√								√						√	
X000	U										U						A		
X001											Dir						B		
X002		U																	
X003			U																
X004												Dir						A	
X005				U								U						B	

* C600、C620、C630 can be 80KHz with customer's special requirements

XC3-19AR-E																			
	Increment Mode										Pulse + direction mode				AB phase mode				
	C600	C602	C604	C606	C608	C610	C612	C614	C616	C618	C620	C622	C624	C626	C628	C630	C632	C634	
Max. Freq.	10K	10K	10K	10K							10K	10K					5K	5K	
4-time Freq.																		√	
Count Interrupt	√	√	√	√								√						√	
X000	U										U						A		
X001											Dir						B		
X002		U										U						A	
X003												Dir						B	
X004			U																
X005				U															

XC3-48、60 PLC																			
	Increment Mode										Pulse + direction mode					AB phase mode			
	C600	C602	C604	C606	C608	C610	C612	C614	C616	C618	C620	C622	C624	C626	C628	C630	C632	C634	
Max. Freq.	80K	80K	10K	10K							80K	80K					80K	80K	
4-time Freq.																		√	
Count Interrupt	√	√	√	√								√						√	
X000	U										U						A		
X001											Dir						B		
X002		U										U						A	
X003												Dir						B	
X004			U																
X005				U															

XC3-24/32/42 PLC and XC5-48/60 PLC																			
	Increment Mode										Pulse+Direction Mode					AB phase Mode			
	C600	C602	C604	C606	C608	C610	C612	C614	C616	C618	C620	C622	C624	C626	C628	C630	C632	C634	
Max. Freq.	80K	80K	10K	10K	10K	10K					80K	10K	10K				80K	5K	5K
4-time Freq.																	√		√
Count Interrupt	√	√	√	√	√	√					√						√		
X000	U										U						A		
X001		U									Dir						B		
X002																			
X003			U									U						A	
X004												Dir						B	
X005																			
X006				U									U						A
X007													Dir						B
X010																			
X011					U														
X012						U													

Note: XC5-48/60: C622 and C632 max frequency is 80 KHz.

XC5-24/32 PLC、XCM-24/32 T4 PLC																		
	Increment Mode										Pulse + direction mode				AB phase mode			
	C600	C602	C604	C606	C608	C610	C612	C614	C616	C618	C620	C622	C624	C626	C628	C630	C632	C634
Max. Freq.	80K	10K									80K					80K		
4-time Freq.																√		
Count Interrupt	√	√									√					√		
X000	U										U					A		
X001											Dir					B		
X002																		
X003		U																

XCC-32 PLC																		
	Increment Mode										Pulse+Direction Mode							
	C600	C602	C604	C606	C608	C610	C612	C614	C616	C618	C630	C632	C634	C636	C638			
Max. Freq.	80K	80K	80K	10K	10K						80K	80K	80K	10K	10K			
4-time Freq.											√	√	√	√	√			
Count Interrupt	√	√	√	√	√						√	√	√	√	√			
X000	U										A							
X001											B							
X002		U										A						
X003												B						
X004			U										A					
X005													B					
X006				U										A				
X007														B				
X010					U										A			
X011															B			

XCM-24/32 T3																		
	Increment Mode										Pulse+Direction Mode				AB phase Mode			
	C600	C602	C604	C606	C608	C610	C612	C614	C616	C618	C620	C622	C624	C626	C628	C630	C632	C634
Max. Freq.	80K	10K	10K	10K							80K	10K				80K	10K	
4-time Freq.																√		
Count Interrupt	√	√									√					√		
X000	U										U					A		
X001											Dir					B		
X002																		
X003		U										U					A	
X004												Dir					B	
X005																		
X006			U															
X007				U														

Note: X7 cannot used with Y0 at the same time.

XCM-60T																		
	Increment Mode										Pulse+Direction Mode				AB phase Mode			
	C600	C602	C604	C606	C608	C610	C612	C614	C616	C618	C620	C622	C624	C626	C628	C630	C632	C634
Max. Freq.	80K	10K	10K	10K												80K	10K	10K
4-time Freq.																√	√	√
Count Interrupt	√	√														√		
X000	U															A		
X001		U														B		
X002																		
X003																		
X004																		
X005																		
X006			U														A	
X007																	B	
X010				U														A
X011																		B

5-3-4. AB Phase Counter's Frequency Multiplication Setting

To AB phase counter, user can modify the value in FLASH data registers FD8241, FD8242, FD8243 to set the frequency multiplication value. When the value is one, it is one time frequency; when the value is four, it is 4 times frequency.

Register	Function	Setting Value	Content
FD8241	Frequency Multiplication of C630	1	1 time frequency
		4	4 time frequency
FD8242	Frequency Multiplication of C632	1	1 time frequency
		4	4 time frequency
FD8243	Frequency Multiplication of C634	1	1 time frequency
		4	4 time frequency

※1: For more information about high speed counter, please refer to XC series PLC instruction manual

※2: To some special model, only one axis can be set as one time frequency or 4 times frequency, the left two axes are separately one time frequency and 4 times frequency.

6 Output Specification and Wiring Methods

In this chapter, we tell the output specification and external wiring methods of XC series PLC. The connection method differs according to different model; the main reason is the terminal's position. For each model's terminal arrangement, please refer to chapter 2-3;

6-1. Output Specifications

6-2. Relay Output Type

6-3. Transistor Output Type

6-1. Output Specification

1

Relay Output

Interior power		Below AC250V、DC30V
Circuit insulation		Mechanism insulation
Action denote		LED indicate lamp
Max load	Resistant load	3A
	Induce load	80VA
	Lamp load	100W
Open circuit's leak current		-
Mini load		DC5V 2mA
Response time	OFF→ON	10ms
	ON→OFF	10ms

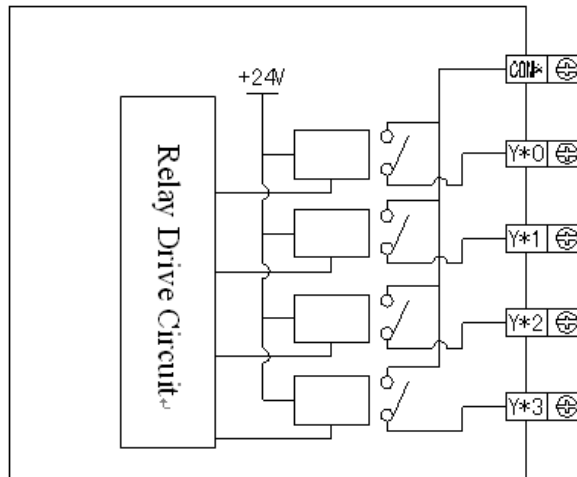

2	Normal Transistor Output
---	---------------------------------

Interior power		Below DC5~30V
Circuit insulation		Optical coupling insulation
Action denote		Indicate lamp LED
Max load	Resistance load	0.8A
	Induce load	12W/DC24V
	Lamp load	1.5W/DC24V
Open circuit's leak current		-
Mini load		DC5V 2mA
Response time	OFF→ON	Below 0.2ms
	ON→OFF	Below 0.2ms

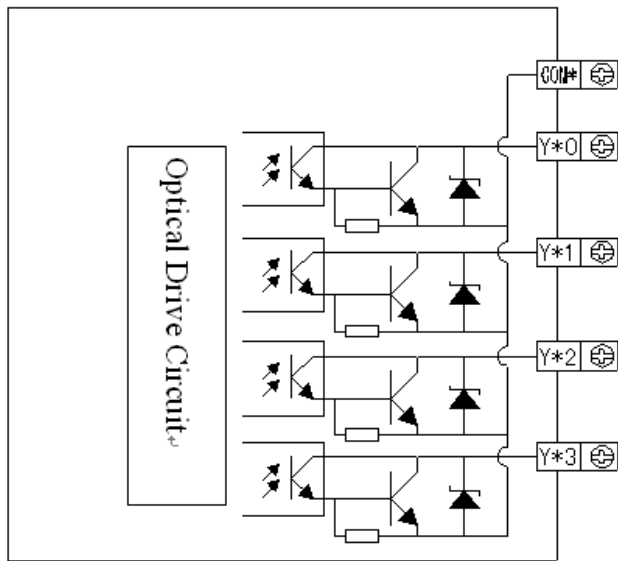

3	High Speed Pulse Output
---	--------------------------------

Model	RT or T Type
High Speed Pulse Output Terminal	Common models are Y0、 Y1； XC5-24/32 model is Y0~Y3
External Power Supply	Below DC5~30V
Action Indication	LED Lamp
Maximum Current	50mA
Max output frequency of pulse	200KHZ

- Note: 1. XCM-24/32T4、 XCM-24/32T3、 XCM-60T、 XCC-32: the high speed pulse output terminals are Y0~Y3、 Y0~Y2、 Y0~Y11、 Y0~Y4.
2. High speed pulse output terminal Y1 cannot use together with expansion BD.

6-2. Relay Output Type

1	Relay Output Circuit
---	-----------------------------

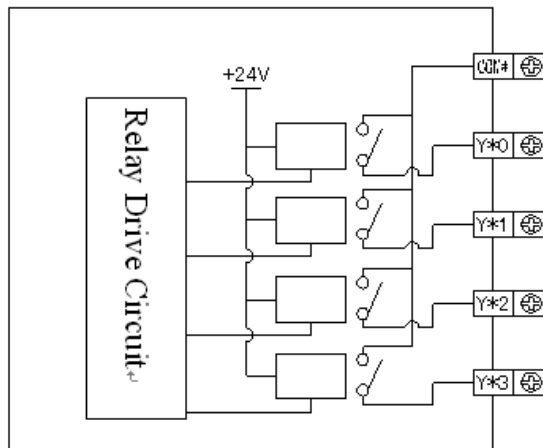

- Output terminals**
 Relay output type includes 2~4 public terminals. So each public-end unit can drive different power-voltage system's (E.g.: AC200V, AC100V, DC24V etc.) load.
- Circuit's insulation**
 Between the relay output coils and contacts, PLC's interior circuits and exterior circuits, load circuits are electric insulation. Besides, each public-end blocks are separate.

- **Action display**
LED lamp lights when output relay's coils galvanize, output contacts are ON.
- **Response time**
From the output relay galvanize (or cut) to the output contacts be ON (or OFF), the response time is about 10ms
- **Output current**
The current-voltage below AC250V can drive the load of pure resistance 2A/1 point, inductance load below 80VA (AC100V or AC200V) and lamp load below 100W (AC100V or AC200V) .
- **Open circuit's leak current**
When the output contact be OFF and there's no leak current, can directly drive Ne lamp etc.
- **The life of relay output contacts**
Standard life of induce AC load such as contactor、electromagnetism valve: 5 million times for 20VA load. Cut power device's life according to the company's test: for 80VA load, the action life is up to 2 million times. But if the load parallel connection with surge absorber, the life will be greatly improved.

2	Output Connection Example
---	----------------------------------

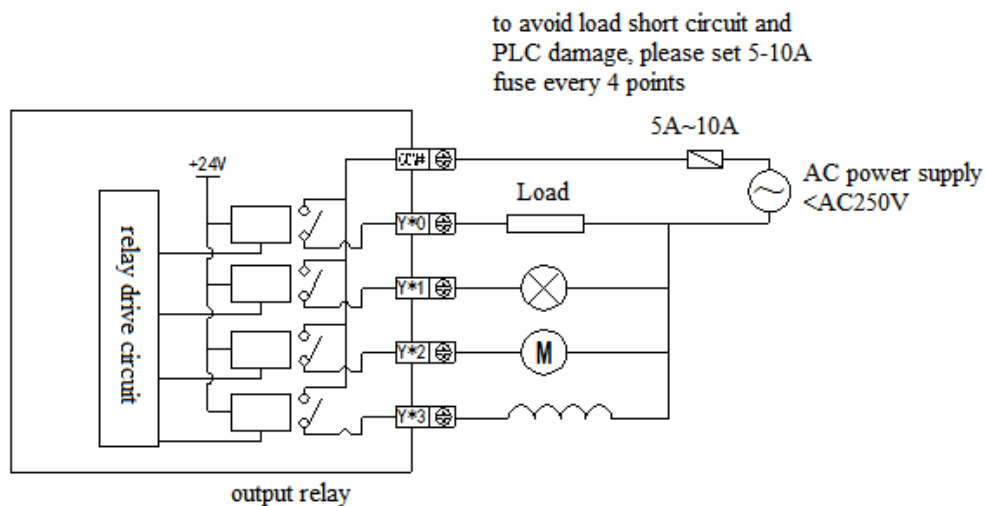

3	Constitution of output circuit
---	---------------------------------------

- For DC induce load, please parallel connect with commutate diode. If not connect with the commutate diode, the contact's life will be decreased greatly. Please choose the commutate diode which allow inverse voltage endurance up to 5~10 times of the load's voltage, ordinal current exceeds load current.
- Parallel connect AC induce load with surge absorber can reduce noise.

4	DC Load
---	----------------

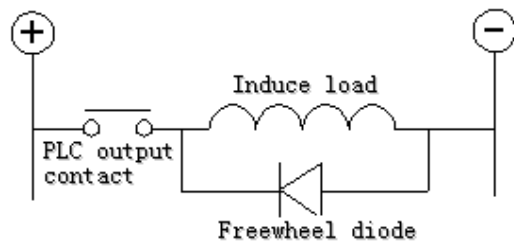

5	AC Load
---	----------------

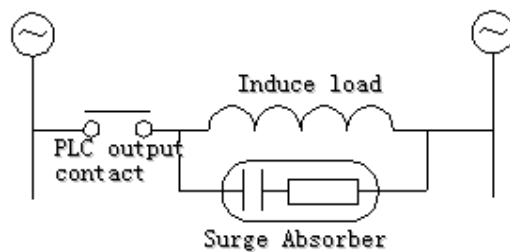

6-3. Transistor Output Type

Transistor output models support high speed pulse output and normal transistor these two types;

1 Normal Transistor Output

- Output Terminals
There are 1~4 COM outputs on transistor output type CPU units
- External Power Supply
Please use DC5~30V power supply to drive the load drive.
- Circuit Isolation
Inside PLC, we use optical couples to isolate the internal circuit with the output transistors; besides, public blocks isolate to each other.
- Action Indication
When driving optical couples, LED will be ON, the output transistors will be ON;
- Response Time
From optical couple being ON (or OFF) to transistor being ON (or OFF), PLC needs time below 0.2ms.
- Output current
Each output's current is 0.5A. But limited by the temperature rising, every 4 points' total current should be below 0.8A.
- Open circuit current
Below 0.1mA

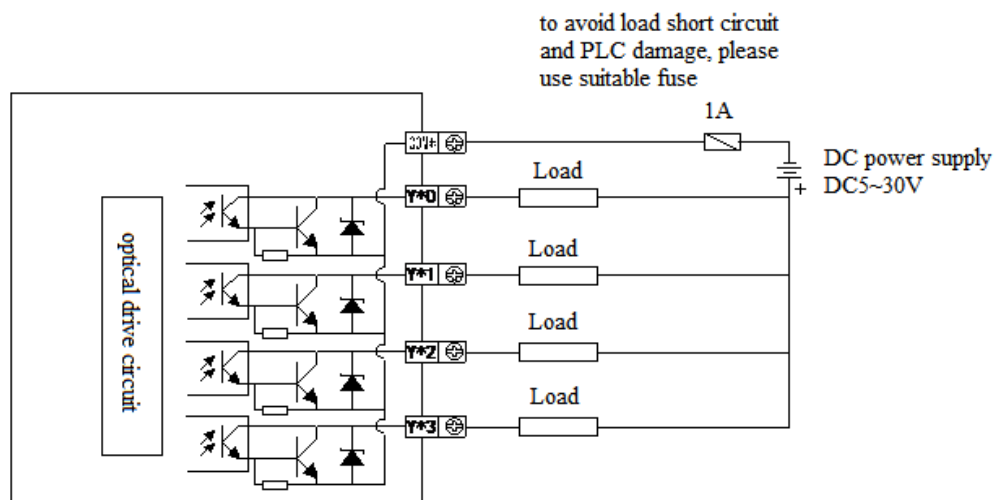

E.g.: Below is the connection diagram of RT/T type PLC with servo driver:

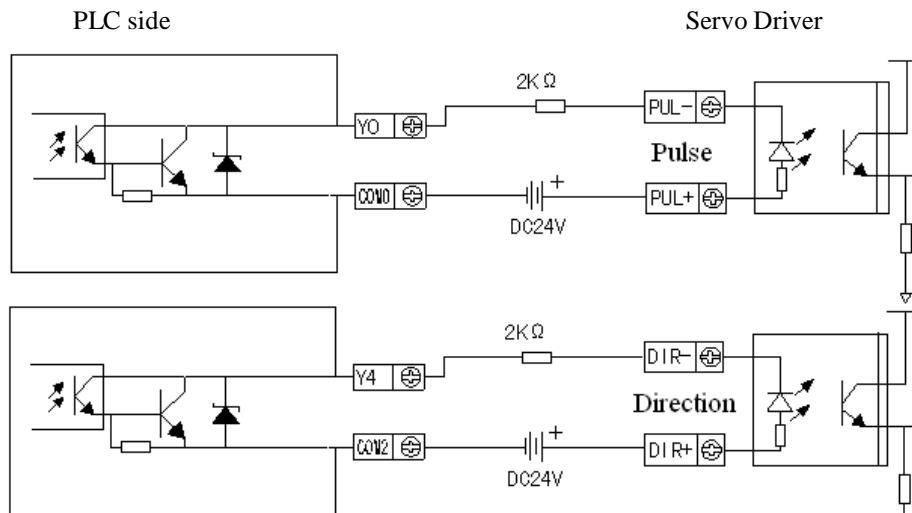

(Make sure the driver's optical couple's input terminal has 8~15mA reliable current)

7 Run, Debug, Maintenance

In this chapter, we tell the whole using process of PLV, from programming till using. It includes running, debug and maintenance of PLC.

7-1. Run and Debug

7-2. Daily Maintenance

7-1. Run and Debug

1 Check the Products

When get the products, please check if the input/output terminals are correct, if there is any component missed. Generally, you can power on the PLC directly at this time. Check if PWR and RUN LED are ON.

2 Write and Download the Program

After confirming the products, please write the program for PLC. You can write the program via computer. Then download the program to your PLC. The general operation steps are listed below:

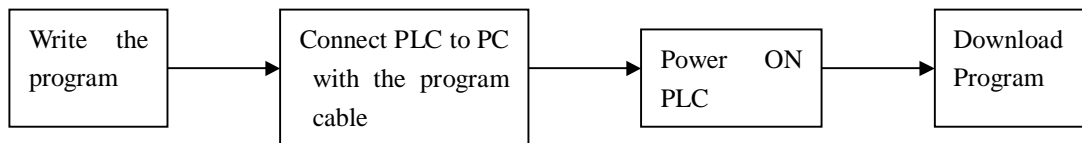

※1: Please link the download cable before you power on the PLC. Or else the COM port will be easily damaged! The method to connect BD card and expansion is same.

3 Debug the Products

In Ideal condition, PLC is in running mode. But if you find some mistakes in the program and you need to modify the program, you should write the new program to the running PLC;

- Connect PLC to PC with the program cable
- Upload the program in PLC
- Modify the uploaded program; we suggest you to save the modified program;
- Pause the running of PLC, download the modified program to PLC;
- Use ladder monitor, free monitor to monitor PLC
- If the program still cannot fulfill your requirement, you can go on modify it and download to PLC.

4 LED on PLC

- When PLC is running correctly, the **PWR** and **RUN** LED should keeps be ON;

- If **ERR** LED keeps be ON, it indicates that PLC running is in error, please correct the program in time
- If **PWR** LED is OFF, it indicates that the power supply is in error, please check your wiring;

7-2. Daily Maintenance

1 Regular Check on Products

Even the PLC has certain anti-interfere ability and strong stability, you should check the PLC regularly.

The check items include:

- Check if the input/output terminals, power supply terminals are loosen
- Check if the COM ports are correct
- Check if the PWR LED, I/O LED can be ON
- Clear the dusts on PLC, to avoid the dusts fall into PLC
- Manage to make PLC running, the storage environment fits the standard told in chapter 2-1-1

2 About the battery

There is no any component in PLC to shorten the life of the battery, so the battery can work all the time. However, if your PLC supports clock function, you should change the battery regularly.

- The battery's life is usually 3~5 years;
- If you need the replay output PLC type, and the relay needs to open/close frequently, or drive large capacity load, the battery's life may be decreased
- If you find battery's power decreased, please change it at your earliest
- After changing the battery, please power it on at your earliest, or else the battery will run out of power automatically.

3 Abandon

If you make sure to abandon the products, please treat the products as the industrial waste.

8 Expansion Devices

XC series PLC expansions include expansion modules and expansion BD cards. The expansion modules include input/output expansion module, analogue, temperature expansion modules; BD cards include analogue temperature, communication applications etc. Via the expansion devices, XC series PLC is applied widely to temperature, flow, liquid, pressure fields etc.

8-1. Module's Summary

8-2. Input/output modules

8-3. Analogue Temperature Modules

8-4. Expansion BD cards

8-1. MODULES SUMMARY

1 General Specifications

Item	Content
Using environment	No corrosive gas
Environmental Temperature	0°C~60°C
Stock temperature	-20~70°C
Environmental Humidity	5~95%
Stock Humidity	5~95%
Installation	Use M3 screws to fix or install on DIN46277 (width 35mm) DIN

2 Module's Structure

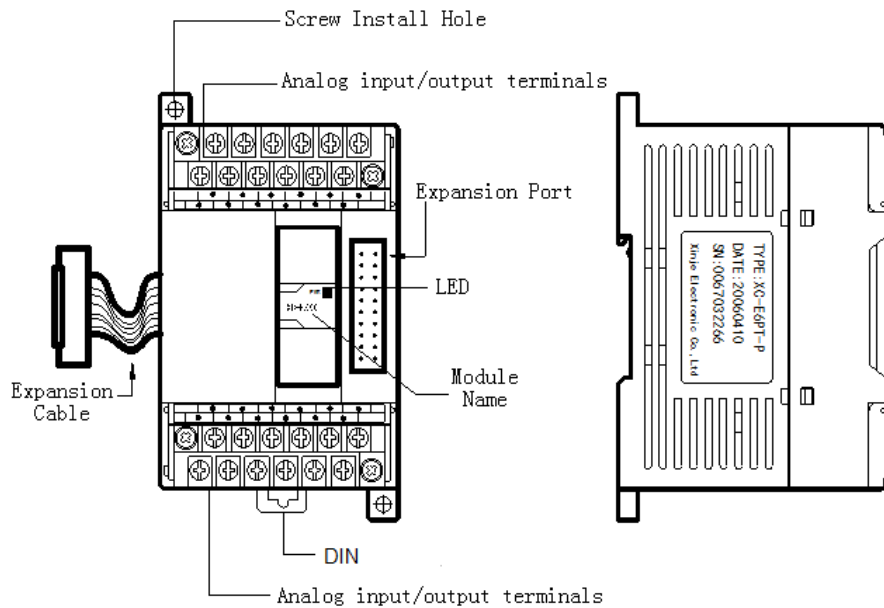

Name	Function
Power Supply Indication	The LED is ON when power on the module
Module Name	The model name of this special module
Expansion Port	Link with other expansion module
Analogue input/output	Used to connect with analogue input/output and peripheral

terminal	equipments, can be removed
DIN guild rail	Used to install the module directly
Screws install hole	Put M3 screw in the hole to finish installation
Expansion Cable	Realize data transfer by linking this cable to with PLC extension port

3 External Dimension

● Graph 1 (Unit: mm)

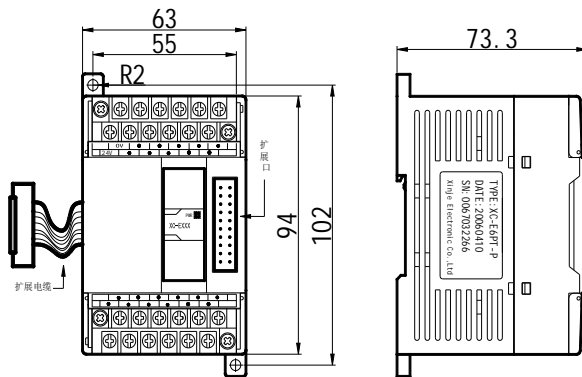

Suitable Models

Module Type	Model
Digital Input/output	8I/O、16I/O
Analogue	All
Temperature	All
Mixture	All

● Graph 2 (Unit: mm)

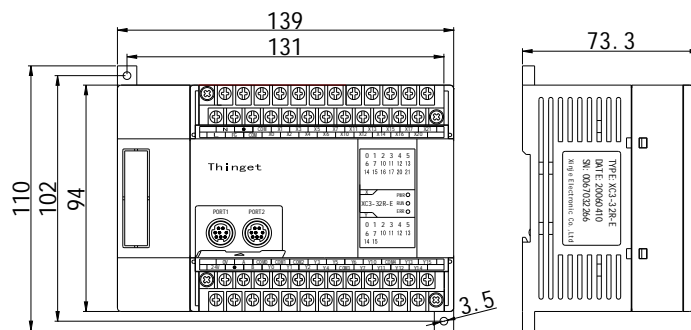

Suitable Models

Module Type	Model
Digital Input/output	32I/O
Analogue	None
Temperature	None
Mixture	None

4 Module Configuration

XC series modules can connect on the right side of XC-PLC main units:

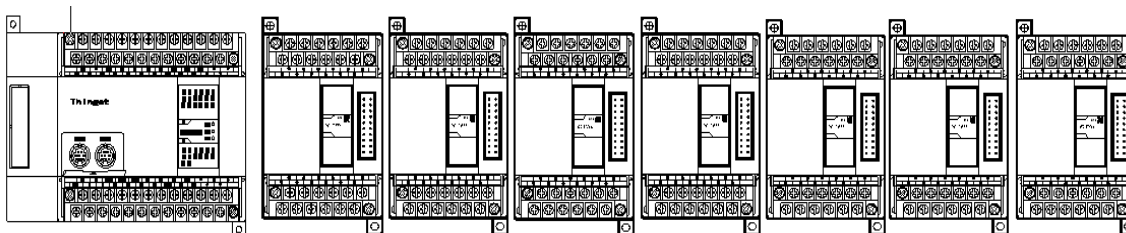

- Digital input/output quantity is in octal form;
- Input/output analog is in decimal form
- PLC main units can work with seven expansions and one extra BD card. The expansion module can be any type (analog or digital, temperature);

8-2. Digital Input/output Modules

Input/output expansions, I/O ranges 8~32, Input type, output type, input/output type, transistor output, relay output etc.

1	Model List
---	-------------------

The detailed models are listed below:

	Model			I/O Nr.	Input Nr. (DC24V)	Output Nr. (R,T)
	Input	Output				
		Relay Output	Transistor Output			
N P N	XC-E8X	-	-	8	8	-
	-	XC-E8YR	XC-E8YT	8	-	8
	-	XC-E8X8YR	XC-E8X8YT	16	8	8
	XC-E16X	-	-	16	16	-
	-	XC-E16YR	XC-E16YT	16	-	16
	-	XC-E16X16YR	XC-E16X16YT	32	16	16
	XC-E32X	-	-	32	32	-
	-	XC-E32YR	-	32	-	32
P N P	XC-E8PX	-	-	8	8	-
	-	XC-E8YR	XC-E8YT	8	-	8
	-	XC-E8PX8YR	XC-E8PX8YT	16	8	8
	XC-E16PX	-	-	16	16	-
	-	XC-E16YR	XC-E16YT	16	-	16
	-	XC-E16PX16YR	XC-E16PX16YT	32	16	16
	XC-E32PX	-	-	32	32	-
	-	XC-E32YR	-	32	-	32

2 Module Specification

Power Supply Specification

DC24V (32 I/O expansions is AC220V)

- Input Specification

Input Items	Content
Input signal's voltage	DC24V±10%
Input signal's current	7mA/DC24V
Input ON current	Up to 4.5mA
Input OFF current	Low than 1.5mA
Input response time	About 10ms
Input signal's format	Contact input or NPN open collector transistor
Circuit insulation	Photo-electricity coupling insulation
Input action's display	LED light when input ON

- Relay output

Input Items	Content	
Internal power	Below AC250V, DC30V	
Circuit insulation	Mechanism insulation	
Action denote	LED indicate lamp	
Max load	3A	3A
	80VA	80VA
	100W	100W
Min load	DC5V 2mA	
Response time	OFF → ON	10ms
	ON → OFF	10ms

- Transistor Output

Input Items	Content	
Internal power	Below DC5~30V	
Circuit insulation	Optical coupling insulation	
Action denote	Indicate lamp LED	
Max load	0.8A	0.8A
	12W/DC24V	12W/DC24V
	1.5W/DC24V	1.5W/DC24V

Min load	DC5V 2mA	
Response time	OFF → ON	Below 0.2ms
	ON → OFF	Below 0.2ms

3 Terminal Arrangement

- XC-E8X

	24V	COM	X1	X3	X5	X7	
OV	COM	X0	X2	X4	X6		

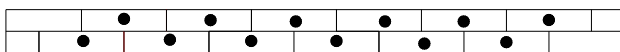

- XC-E8YR, XC-E8YT

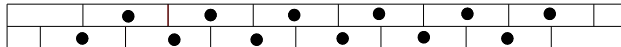

	Y0	Y1	Y2	COM3	Y5	Y7	
COM0	COM1	COM2	Y3	Y4	Y6		

- XC-E8X8YR, XC-E8X8YT

	24V	COM	X1	X3	X5	X7	
OV	COM	X0	X2	X4	X6		

	Y0	Y1	Y2	COM3	Y5	Y7	
COM0	COM1	COM2	Y3	Y4	Y6		

- XC-E16X

	24V	COM	X1	X3	X5	X7	
OV	COM	X0	X2	X4	X6		

	COM	X11	X13	X15	X17		
COM	X10	X12	X14	X16			

- XC-E16YR, XC-E16YT

	Y0	Y1	Y2	COM3	Y5	Y7	
COM0	COM1	COM2	Y3	Y4	Y6		

	Y10	Y11	Y12	COM7	Y15	Y17	
COM4	COM5	COM6	Y13	Y14	Y16		

- XC-E32X

	N	COM	X1	X3	X5	X7	X11	X13	X15	X17	
L	FG	COM	X0	X2	X4	X6	X10	X12	X14	X16	

	OV	COM	X21	X23	X25	X27	X31	X33	X35	X37	
24V		COM	X20	X22	X24	X26	X30	X32	X34	X36	

- XC-E32YR, XC-E32YT

	N	●	Y0	Y2	COM1	Y5	Y7	Y20	Y22	COM3	Y25	Y27		
L	FG	COM0	Y1	Y3	Y4	Y6	COM2	Y21	Y23	Y24	Y26			

	OV	●	Y20	Y23	COM5	Y25	Y27	Y30	Y32	COM7	Y35	Y37		
24V	●	COM4	Y22	Y23	Y24	Y25	COM6	Y31	Y33	Y34	Y36			

● XC-E16X16YR

	N	●	COM	X1	X3	X5	X7	X11	X13	X15	X17	●		
L	FG	COM	X0	X2	X4	X6	X10	X12	X14	X16	●			

	OV	●	Y0	Y2	COM1	Y5	Y7	Y10	Y12	COM3	Y15	Y17		
24V	●	COM0	Y1	Y3	Y4	Y6	COM2	Y11	Y13	Y14	Y16			

8-3. Analogue, Temperature Modules

As the special modules of XC series PLC, analogue and temperature modules can work with XC series PLC, apply in process controls like temperature, pressure, flow etc.

For details, please refer to 《XC series analogue/temperature expansions manual》

The detailed modules are listed below:

Model	Function
XC-E8AD	8 channels analog input (14bit); 4 channels current input, 4 channels voltage input
XC-E4AD2DA	4 channels analog input (14bit); 2 channels analog output (12bit); current, voltage selectable
XC-E4AD	4 channels analog input (14bit); current, voltage selectable
XC-E4DA	4 channels analog output (12bit); current, voltage selectable
XC-E2DA	2 channels analog output (12bit); current, voltage selectable
XC-E6PT-P	-100°C ~ 350°C, 6 channels Pt100 temperature sampling, 0.1 degree precision, include PID operation
XC-E6TCA-P	0°C ~ 1000°C, 6 channels K type thermocouple temperature sampling module, 0.1 degree precision, include PID operation
XC-E3AD4PT2DA	3 channels current input (14bit), 4 channels Pt100 temperature sampling and 2 channels 10 bits voltage output
XC-E2AD2PT2DA	2 channels current input (14bit), 2 channels Pt100 temperature sampling (16bit), and 2 channels 10 bits voltage output

8-3-1. XC-E8AD

1 Brief Introduction

- 14 bits high precision analog input
- 8 channels analog input: The first four channels voltage input (0~5V、0~10V two kinds); The left 4 channels current input (0~20mA、4~20 mA two kinds)
- As special function module of XC, 7 models could be connected at most.
- Support PID auto tune function

2 Specification

Items	Voltage input (0CH-3CH)	Current input (4CH-7CH)
Analog input bound	DC0~5V, 0~10V	DC0~20mA, 4~20mA
Max input bound	±18V	0~40mA
Digital output bound	14 bits binary data	
PID control value	0~K4095	
Distinguish Ratio	1/16383 (14Bit)	
Integrate Precision	0.8%	
Convert speed	20ms/channel	
Power used by analog	DC24V±10%, 100mA	

3 Terminal Arrangement

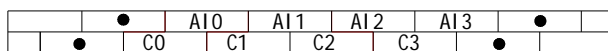
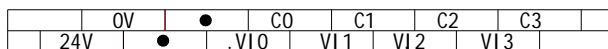

CH	NAME	SIGNAL	CH	NAME	SIGNAL
CH0	AI0	VI0+ voltage input	CH1	AI1	VI1+ voltage input
	C0	VI0- voltage input		C1	VI1- voltage input
CH2	AI2	VI2+ voltage input	CH3	AI3	VI3+ voltage input
	C2	VI2- voltage input		C3	VI3- voltage input

CH4	VI0	AI0+ current input	CH5	VI1	AI1+ current input
	C0	AI0- current input		C1	AI1- current input
CH6	VI2	AI2+ current input	CH7	VI3	AI3+ current input
	C2	AI2- current input		C3	AI3- current input
-	24V	+24V power supply			
	0V	COM of power supply			

8-3-2. XC-E4AD2DA

1 Brief Introduction

- 4CH analogue input: voltage and current input selectable; Voltage input range is 0~5V, 0~10V selectable, current input range is 0~20mA, 4~20mA selectable;
- 2CH analogue output: voltage and current input selectable; Voltage input range is 0~5V, 0~10V selectable, current input range is 0~20mA, 4~20mA selectable;
- 14 bits high precision analogue input;
- As the special module, 7pcs XC-E4AD2DA can be connected to one XC series PLC main unit;
- XC-E4AD2DA module four A/D channels have PID function.

2 Specification

Items	Analogue Input		Analogue Output	
	Voltage Input	Current Input	Voltage output	Current Output
Analogue Input Range	0~5V,0~10V	0~20mA,4~20mA	-	
Max Input Range	DC±18V	0~40mA	-	
Analogue Output Range	-		0~5V、0~10V, (external load resistor 2KΩ~1MΩ)	0~20mA,4~20mA (external load resistor 500Ω)
Digital Input Range	-		12bits binary (0~4095)	
Digital Output Range	14 bits binary (0~16383)		-	

Distinguish Ratio	1/16383(14Bit); the convert data is stored in PLC in form of Hex. (14Bit)	1/4095(12Bit); the convert data is stored in PLC in form of Hex. (14Bit)
PID Output Value	0~K4095	
Integral precision	0.8%	
Convert Speed	20ms/CH	3ms/CH
Power Supply	DC24V±10%, 100mA	

3 Terminal Arrangement

	0V	●		C0	A00		C1	A01	
	24V	●		●	V00	●		V01	

	VI0		C1		A11		VI2		C3		A13	
	C0		AI0		VI1		C2		AI2		VI3	

CH	NAME	SIGNAL	CH	NAME	SIGNAL
CH0	AI0	Current analogue input	CH1	AI1	Current analogue input
	VI0	Voltage analogue input		VI1	Voltage analogue input
	C0	COM of CH0		C1	COM of CH1
CH2	AI2	Current analogue input	CH3	AI3	Current analogue input
	VI2	Voltage analogue input		VI3	Voltage analogue input
	C2	COM of CH2		C3	COM of CH3
CH0	AO0	Current analogue output	CH1	AO1	Current analogue output
	VO0	Voltage analogue output		VO1	Voltage analogue output
	C0	COM of CH0		C1	COM of CH1
-	24V	+24V power supply			
	0V	COM of power supply			

8-3-3. XC-E4AD

1 Brief Introduction

- 4CH analogue input: voltage and current input selectable; Voltage input range is 0~5V, 0~10V selectable, current input range is 0~20mA、4~20mA selectable;
- 14 bits high precision analogue input;
- As the special module, 7pcs XC-E4AD can be connected to one XC series PLC main unit;
- XC-E4AD module support PID auto tune function;

2 Specification

Items	Analogue Input (AD)	
	Voltage Input	Current Input
Analogue Input Range	DC0~5V, 0~10V	DC0~20mA, 4~20mA
Max Input Range	DC±18V	DC0~40mA
Analogue Output	-	
Digital Input Range	-	
Digital Output Range	14 bits binary (0~16383)	
Distinguish Ratio	1/16383(14Bit); the convert data is stored in PLC in form of Hex. (14Bit)	
PID Output Value	0~K4095	
Integral precision	0.8%	
Convert Speed	20ms/CH	
Power Supply	DC24V±10%, 100mA	

3 Terminal Arrangement

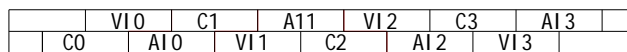

CH	NAME	SIGNAL	CH	NAME	SIGNAL
CH0	AI0	Current analogue input	CH1	AI1	Current analogue input
	VI0	Voltage analogue input		VI1	Voltage analogue input
	C0	COM of CH0		C1	COM of CH1
CH2	AI2	Current analogue input	CH3	AI3	Current analogue input
	VI2	Voltage analogue input		VI3	Voltage analogue input
	C2	COM of CH2		C3	COM of CH3
-	24V	+24V power supply			
	0V	COM of power supply			

8-3-4. XC-E4DA

1 Brief Introduction

- 4CH analogue output: voltage and current input selectable; Voltage input range is 0~5V, 0~10V selectable, current input range is 0~20mA, 4~20mA selectable;
- 10 bits high precision analogue output;
- As the special module, 7pcs XC-E4DA can be connected to one XC series PLC main unit;

2 Specification

Items	Voltage Output	Current Output
Analogue Output Range	DC0~5V, 0~10V (external load resistor 2K Ω ~1M Ω)	DC0~20mA, 4~20mA (external load resistor less than 500 Ω)
Digital Input Range	12 bits binary	
Distinguish Ratio	1/4095(12Bit); the convert data is stored in PLC in form of Hex. (12Bit)	
Integral Precision	0.8%	
Convert Speed	3ms/CH	
Power Supply	DC24V \pm 10%, 100mA	

3 Terminal

	0V	●	C0	A00	C1	A01	
	24V	●	●	V00	●	V01	

	●	●	●	C2	A02	C3	A03
	●	●	●	V02	●	V03	

CH	NAME	SIGNAL	CH	NAME	SIGNAL
CH0	AO0	Current analogue output	CH1	AO1	Current analogue output
	VO0	Voltage analogue output		VO1	Voltage analogue output
	C0	COM of CH0		C1	COM of CH1

CH2	AO2	Current analogue output	CH3	AO3	Current analogue output
	VO2	Voltage analogue output		VO3	Voltage analogue output
	C2	COM of CH2		C3	COM of CH3
-	24V	+24V power supply			
	0V	COM of power supply			

8-3-5. XC-E2DA

1 Brief Introduction

- 2CH analogue output: voltage and current input selectable; Voltage input range is 0~5V、0~10V selectable, current input range is 0~20mA、4~20mA selectable;
- 12 bits high precision analogue input;
- As the special module, 7pcs XC-E2DA can be connected to one XC series PLC main unit;

2 Specification

Items	Voltage Output	Current Output
Analogue Output Range	DC0~5V、0~10V	DC0~20mA、4~20mA
	External Load Resistor (2K Ω ~1M Ω)	External Load Resistor less than 500 Ω
Digital Input Range	12 bits binary	
Distinguish Ratio	1/4096(12Bit); the convert data is stored in PLC in form of Hex. (12Bit)	
Integral Precision	0.8%	
Convert Speed	3ms/CH	
Power Supply	DC24V \pm 10%, 100mA	

3 Terminal Arrangement

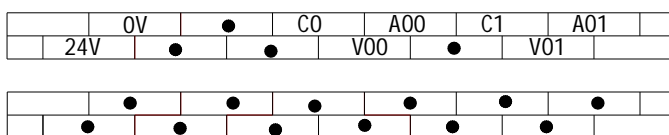

CH	NAME	SIGNAL
CH0	AO0	Current analogue output
	VO0	Voltage analogue output
	C0	COM of CH0
CH1	AO1	Current analogue output
	VO1	Voltage analogue output
	C1	COM of CH1
-	24V	+24V power supply
	0V	COM of power supply

8-3-6. XC-E6PT-P

1 Brief Introduction

- Pt resistor input, the scale is Pt100
- 6CH input, 6CH output, 2 groups PID parameters (3CH/group)
- 1mA constant output, doesn't effected by the environment;
- The distinguish precision is 0.1 °C
- As the special module, 7pcs XC-E6PT-P can be connected to one XC series PLC main unit;

2 Specification

Items	Content
Analogue Input Signal	Pt100 resistor
Temperature testing range	-100°C~350°C
Digital Output range	-1000~3500, 16bits with sign, binary
Control precision	±0.5°C
Distinguish Ratio	0.1°C
Integral Precision	0.8% (Relate to the max value)
Convert Speed	20ms/CH
Power Supply	DC24V±10%, 50mA

※1: If no signal input, the value is 3500;

※2: According to the actual requirements, connect with Pt100 resistors

3 Terminal Arrangement

	OV	COM0	COM1	COM2	Y3	Y5
24V	●	Y0	Y1	Y2	Y4	

	A0	A1	A2	A3	A4	A5
C0	C1	C2	C3	C4	C5	

CH	NAME	SIGNAL	CH	NAME	SIGNAL
CH0	A0	0CH thermo-resistor input terminal	CH1	A1	1CH thermo-resistor input terminal
	C0	0CH COM of thermo-resistor input		C1	1CH COM of thermo-resistor input
CH2	A2	2CH thermo-resistor input terminal	CH3	A3	3CH thermo-resistor input terminal
	C2	2CH COM of thermo-resistor input		C3	3CH COM of thermo-resistor input
CH4	A4	4CH thermo-resistor input terminal	CH5	A5	5CH thermo-resistor input terminal
	C4	4CH COM of thermo-resistor input		C5	5CH COM of thermo-resistor input
-	Y0	Output of CH0		Y1	Output of CH1
	Y2	Output of CH2		Y3	Output of CH3
	Y4	Output of CH4		Y5	Output of CH5
-	24V	+24V power supply			
	0V	COM for power supply			
COM0, COM1, COM2: COM for outputs					

8-3-7. XC-E6TCA-P

1 Brief Introduction

- Support many thermocouple types (K, S, E, N, J, T, R types)
- Adopt DC-DC power supply isolate design, enhance the anti-interfere ability;
- The temperature precision is 0.1℃。
- Set each channel's PID parameters independently, equipped with separate register space;
- Support real time PID auto tune function; enable the device to PID auto tune under every status (cold status, heating status, transition status etc), get the best PID values;
- Realize data exchange with FROM and TO instructions, enhance the flexibility, reduce the data exchange quantity, expand the data memory space;

2 Specification

Items	Specifications
Analogue Input Signal	K、S、E、N、J、T、R type thermocouples
Temperature testing range	0°C~1000°C
Digital Output range	0~4095, without sign 12 bits, decimal
Control precision	0.1°C
Distinguish Ratio	0.1°C
Integral Precision	0.1°C
Convert Speed	20ms/CH
Power Supply	DC24V±10%, 50mA

※1: When no signal input, the channel's data is 4095;

※2: According to the actual requirements, connect with the thermo-resistors;

3 Terminal Arrangement

	0V	COM0	COM1	COM2	Y3	Y5	
	24V	●	Y0	Y1	Y2	Y4	

	TC0+	TC1+	TC2+	TC3+	TC4+	TC5+	
	TC0-	TC1-	TC2-	TC3-	TC4-	TC5-	

CH	NAME	SIGNAL	CH	NAME	SIGNAL
CH0	TC0+	CH0 temperature input +	CH1	TC1+	CH1 temperature input +
	TC0-	CH0 temperature input -		TC1-	CH1 temperature input -
CH2	TC2+	CH2 temperature input +	CH3	TC3+	CH3 temperature input +
	TC2-	CH2 temperature input -		TC3-	CH3 temperature input -
CH4	TC4+	CH4 temperature input +	CH5	TC5+	CH5 temperature input +
	TC4-	CH4 temperature input -		TC5-	CH5 temperature input -
Y0~Y5		Output Channel Y0~Y5 Analogue Output: in the form of digital type, the range is 0~4095 Digital Output: in the form of occupy ratio, Y output in the activate time			
-	24V	+24V power supply			
	0V	COM of power supply			

8-3-8. XC-E3AD4PT2DA

1 Brief Introduction

- 3CH 14bits current input、 4CH PT100 temperature input and 2CH 10bits voltage output
- 3CH AD is current (0~20mA、 4~20mA) selectable; 2Ch DA is voltage (0~5V、 0~10V) selectable, choose via the software;
- Pt resistor input, the scale is PT100
- 3CH A/D and 4CH PT input are equipped with PID auto tune function;
- As the special module, 7pcs XC-E3AD4PT2DA can be connected to one XC series PLC main unit;

2 Specification

Items	Analogue Current Input (AD)	Temperature Input (PT)	Analogue Voltage Output (DA)
Analogue input	DC0~20mA, 4~20mA	PT100	-
Temperature testing range	-	-100~350°C	-
Max input range	DC0~40mA	-	-
Analogue output range	-	-	DC0~5V, 0~10V(external load resistor 2K Ω ~1M Ω)
Digital input range	-	-	10 bits Binary (0~1023)
Digital Output Range	14 bits Binary (0~16383)	-1000~3500	-
Distinguish Ratio	1/16383(14Bit): The converted data is stored in PLC in Hex. (14Bit)	0.1°C	1/1023(10Bit): The converted data is stored in PLC in Hex. (10Bit)
PID Output Value	0~K4095		-
Integral Precision	0.8%	\pm 0.5°C	0.8%
Convert Speed	20ms/CH		3ms/CH
Power Supply	DC24V \pm 10%, 100mA		

3 Terminal Arrangement

	0V	AI0	AI1	AI2	V00	V01	
24V	C0	C1	C2	C3	C4		

	B0	A1	C1	B2	A3	C3	
A0	C0	B1	A2	C2	B3		

CH	NAME	SIGNAL	CH	NAME	SIGNAL
0CH	AI0	0CH current Input	1CH	AI1	1CH current Input
	C0	0CH current Input COM		C1	1CH current Input COM
2CH	AI2	2CH current Input			
	C2	2CH current Input COM			
0CH	A0	0CH temperature input	1CH	A1	1CH temperature input
	B0	-		B1	-
	C0	0CH input COM		C1	1CH input COM
2CH	A2	2CH temperature input	3CH	A3	3CH temperature input
	B2	-		B3	-
	C2	2CH input COM		C3	3CH input COM
0CH	VO0	0CH voltage output	1CH	VO1	1CH voltage output
	C3	0CH voltage output COM		C4	1CH voltage output COM
-	24V	+24V power supply			
	0V	power supply COM			

8-3-9. XC-E2AD2PT2DA

1 Brief Introduction

- 2CH 16bits analogue input, 2CH PT100 temperature input and 2CH 10bits analogue output
- 2CH input/output is current, voltage selectable (current: 0~20mA, 4~20mA; voltage: 0~5V, 0~10V), select via XCPPro;
- 2CH A/D and 2CH PT input has PID auto tune function;
- Adopt DC-DC power supply isolation design, enhance the anti-interfere ability;
- The display precision is 0.01 °C
- Set each channel's PID value separately, equipped separate register space;
- Support real time PID auto tune function; enable the device to PID auto tune under every status (cold status, heating status, transition status etc), get the best PID values;
- Realize data exchange with FROM and TO instructions, enhance the flexibility, reduce

the data exchange quantity, expand the data memory space;

2	Specification
----------	----------------------

Items	Analogue Input (AD)		Temp. input (PT)	Analogue output (DA)	
Analogue Input	Current	0~ 20mA 4~ 20mA	PT100	-	
	Voltage	0~5V 0~10V			
Temperature Range	-		-100~327°C	-	
Max input range	DC0~40mA		-	-	
Analogue output range	-		-	Current	0~10V 0~5V
				Voltage	0~20mA 4~20mA
Digital input range	-		-	10 bits binary (0~1023)	
Digital Output range	16 bits binary (0~65535)		-1000~3500	-	
Distinguish Ratio	1/16383(16Bit)		0.01°C	1/1023(10Bit)	
PID Output value	0~K4095			-	
Integral precision	0.8%	±0.01°C		0.8%	
Convert speed	20ms/CH			3ms/CH	
Power supply	DC24V±10%, 100mA				

3	Terminal Arrangement
----------	-----------------------------

	OV	•	•	V00	V01	C01	
	24V	•	•	I00	C00	I01	

	PT0	VB	COM	A10	V11	C11	
	VA	COM	PT1	V10	C10	A11	

Name	Terminals	Comments	
Input terminals	PT0, PT1	Temperature Input	Analogue input, PT100 temperature sensor (-100°C~350°C)
	V10, V11	Analogue Input	Voltage Input 0~10V or 0~5V

Output terminals	AI0, AI1	Analogue Output	Current input	0~20mA or 4~20mA
	VO0, VO1		Voltage Input	in digital form, range: 0~1023
	IO0, IO1		Current input	in digital form, range: 0~1023

Three-line PT100 resistor's input wiring is shown below:

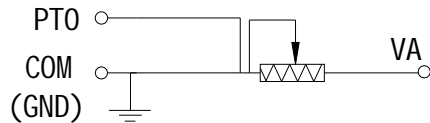

To normal PT100 resistors, wire according to the terminal's color; the terminal with same color can connect to PT1 and COM randomly, the other terminals connect to VA side;

8-4. Expansion BD cards

1 Installation

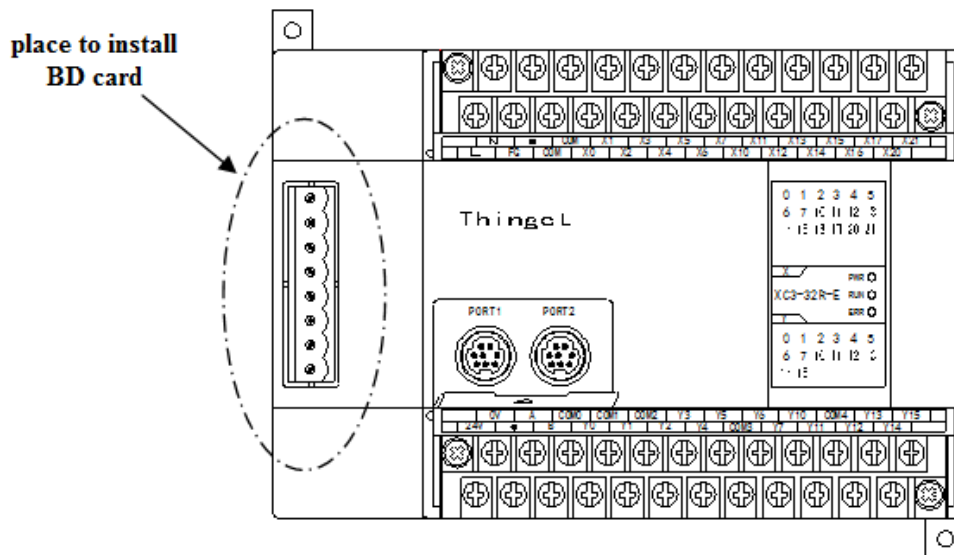

2 Configuration

- 1) Install the BD card on PLC correctly
- 2) Link PLC via XCPPro, in "Configure" menu, choose "BD settings" (See graph below)

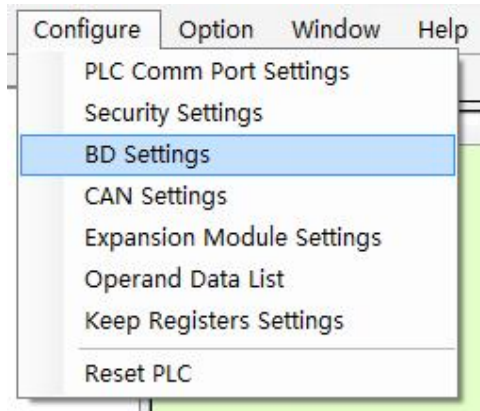

- 3) In “BD settings”, choose “Other BD”, then set BD from the right options; finally download the user program;

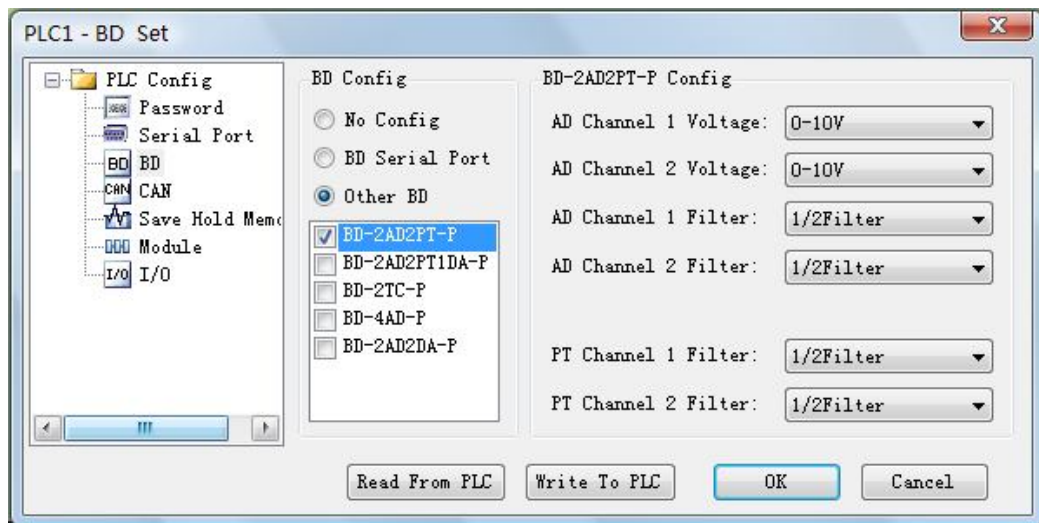

※1: If configure XC-COM-BD, then ‘BD config’ option should choose “BD Serial Port”

8-4-1. XC-2AD2PT-BD

1 Specifications

- 14 bits high precision analogue input
- 2CH voltage 0~10V、0~5V selectable; 2CH temperature input;
- Pt temperature resistor sensor input (Pt100 2-line form)

2 Specification

Items	Voltage Input	Temperature Input
Analogue input signal	DC0~5V, 0~10V (the input resistor is 300k Ω)	Pt resistor Pt100 (2-line)
Temperature testing range	-	-100~350°C
Distinguish	0.15mV (10/16383)	0.1°C
Digital output range	0~16383	-1000~3500
Integral precision	$\pm 0.8\%$ of the full scale	
Convert time	15ms \times 4CH	
PID output value	0~K4095	
Default value	0	3500
Input Specialty		
Isolation	No isolation among PLC's each channel	
I/O occupation	0 I/O (as operate via data register, so I/O is not limited by PLC's standard I/O limitation) (

8-4-2. XC-COM-BD

1 Specifications

- For RS-485 communication
- For RS-232 communication
- RS-232 and RS-485 can't be used at the same time

2 Pins

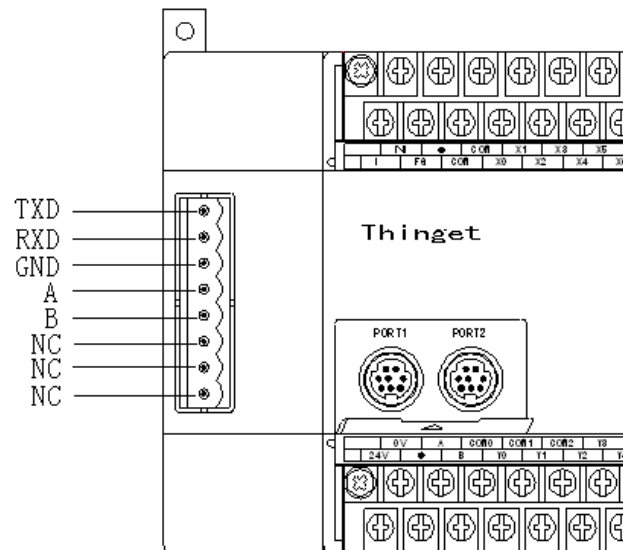

※1: TXD、RXD、GND are RS-232 pins

※2: A、B are RS-485 pins

※3: RS-232 and RS-485 can't be used at the same time

9 change the Soft Components

This chapter focuses on a special function of XC serials PLC, mapping relationship of terminals and soft components. With this special function, users reduce the maintenance job greatly. To the local operation, they will not bother with the damaged terminals any more.

9-1. Function Summary

9-2. Operation Method

9-3. Operated via HMI

9-1. Function Summary

For general PLC, when the internal optical couples, relays or transistors are damaged, the corresponding input/output terminals will be faulty. The only solution is to revise the program. This is troublesome for the user and affects the production greatly;

XC series PLC breaks the one-to-one correspondence. The users only need to change the soft component's value by HMI, then the corresponding terminal will activate. Take advantage of this improvement, the user need not replace the PLC or modify the original program in the condition of PLC terminals damaged.

Before (Complicate and not effective)

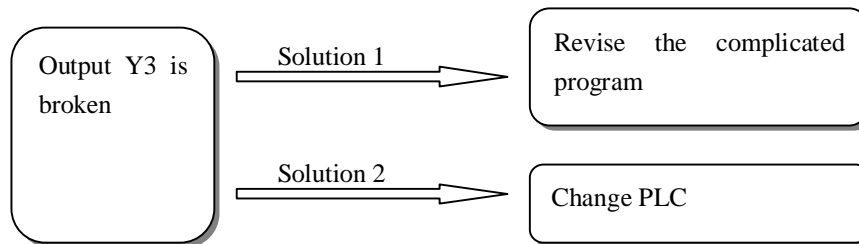

Now (Simple, fast and effective)

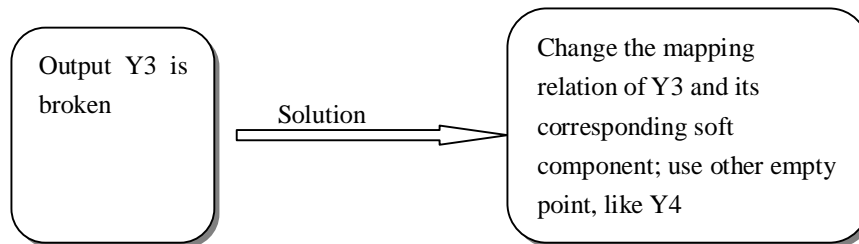

9-2. Operation Method

To the damaged input/output, we can change their mapping relation; replace the damaged input/output points with other. This need not change the user program. In PLC special register, we specify certain address section for user to change the mapping relation. User just finds the mapping relation of the damaged input/output; replace the value in this special register with the value of changed input/output.

Below is the table to modify the input/output point's mapping ID:

Table1 mapping relationship of the Input and soft component

ID.	FUNCTION	DESCRIPTION
FD8010	X00 corresponds to I**	X0 corresponds to the number of input mapping I**
FD8011	X01 corresponds to I**	
FD8012	X02 corresponds to I**	
.....	
FD8073	X77 corresponds to I**	

Table2 mapping relationship of the output and soft component

NO	FUNCTION	INSTRUCTION
FD8074	Y00 corresponds to O**	Y0 corresponds to the number of output mapping O**
FD8075	Y01 corresponds to O**	
FD8076	Y02 corresponds to O**	
.....	
FD8137	Y77 corresponds to O**	

As shown in the table above, the original value is FD8010 is 0, if replace it by value "7", then X7 will represent X0 in the program. Meantime you should change the value in FD8170 to be 0, to realize exchange. In this way, X0 will correspond with external input X7; X7 will correspond with external input X0.

-
- ※1: After changing the mapping relation, please restart the PLC.
 - ※2: When change the mapping relation, please notice, input/output is in octal, but the address ID is in decimal.
 - ※3: When change, should exchange the mapping relation. I.e. if modify X0 ID to be 5, make sure to change X5 ID to be 0;
 - ※4: Mapping relation, must one terminal corresponds to one soft component.
 - ※5: Users can modify the FD value online, but this method is not recommended. Method in chapter 9-3 is recommended to use;
-

9-3. Operated by HMI

User can change the mapping relation by XCP Pro, but PLC must be online with PC. We suggest users to change the mapping relation by HMI. Below is the sample:

There are two screens based on ID60004 and ID60005 in XINJE TP series HMI, they are used to changing the mapping relation of input and output. We just need to put the “Screen Jump” Button in the program interface, touch the Button, jump to the specified screen, and change the mapping relation there.

Modify the input point mapping diagram (HMI screen No.60004), see below:

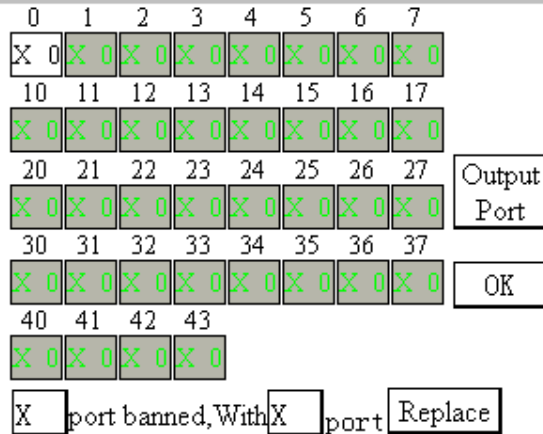

Modify the output point mapping diagram (HMI screen No.60005), see below:



From the above graph, we can see that in the screen we list all the input/output terminals, and it's simple to modify. Below we tell the steps:

Step1

Put the screen jump icon, jump to screen ID60004

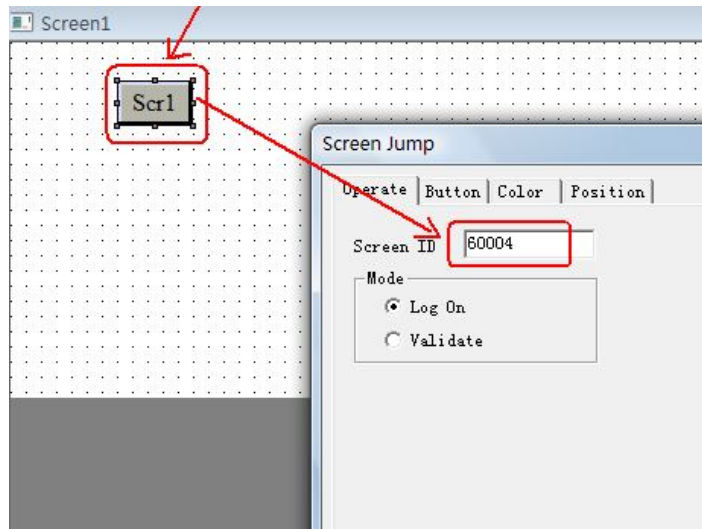

Step2

Click into "Scr1", enter the modify table



Click it; you will see the pop-up window:

Step3

In the pop-up window, click X2, disable the faulty terminal X2

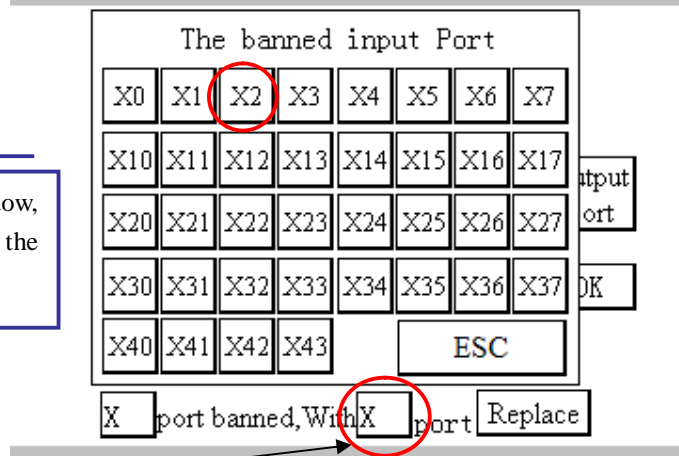

Continue to click it; the replacement window will pop up:

Step4

In the pop-up window, click X4, replace the faulty terminal X2 with X4

0	1	2	3	4	5	6	7
X 0	X 0	X 0	X 0	X 0	X 0	X 0	X 0
10	11	12	13	14	15	16	17
X 0	X 0	X 0	X 0	X 0	X 0	X 0	X 0
20	21	22	23	24	25	26	27
X 0	X 0	X 0	X 0	X 0	X 0	X 0	X 0
30	31	32	33	34	35	36	37
X 0	X 0	X 0	X 0	X 0	X 0	X 0	X 0
40	41	42	43				
X 0	X 0	X 0	X 0				

X 2 port banned, With X port Replace

Step5

Click "Replace", the status table will change, the original X2 changes to be , which means X2 has disabled.

0	1	2	3	4	5	6	7
X 0	X 0	X X	X 0	X 0	X 0	X 0	X 0
10	11	12	13	14	15	16	17
X 0	X 0	X 0	X 0	X 0	X 0	X 0	X 0
20	21	22	23	24	25	26	27
X 0	X 0	X 0	X 0	X 0	X 0	X 0	X 0
30	31	32	33	34	35	36	37
X 0	X 0	X 0	X 0	X 0	X 0	X 0	X 0
40	41	42	43				
X 0	X 0	X 0	X 0				

X port banned, With X port Replace

As in the above graphs, we need only 5 minutes replace I/O terminals. This method avoids us to modify the program, change PLC etc.

※1: After modification, make sure to restart PLC

Appendix Special soft device list

Here we mainly introduce the functions of special soft device, data register and FlashROM, and introduce the address of expansion. Users can scan fast.

Appendix 1-1. Special Auxiliary Relay List

Appendix 1-2. Special Data Register List

Appendix 1-3. Special Module Address List

Appendix 1-4. Special Flash Register List

Appendix 1-1. Special Auxiliary Relay List

PC Status (M8000-M8003)

ID	Function	Description	
M8000	Normally ON coil when running		M8000 keeps being ON status when PLC is running
M8001	Normally OFF coil when running		M8001 keeps being OFF status when PLC is running
M8002	Initial positive pulse coil		M8002 be ON in first scan cycle
M8003	Initial negative pulse coil		M8003 be OFF in first scan cycle

Clock (M8011-M8014)

ID	Function	Description
M8011	Shake with the cycle of 10ms	
M8012	Shake with the cycle of 100ms	
M8013	Shake with the cycle of 10sec	
M8014	Shake with the cycle of 1min	

Flag (M8020-M8029)

ID	Function	Description
M8020	Zero	The plus/minus operation result is 0
M8021	Borrow	“borrow” occurs in minus operation
M8022	Carry	When carry occurs in plus operation or overflow occurs in bit shift operation
M8023		
M8026	RAMP Mode	
M8029		

PC Mode (M8030-M8038)

ID	Function	Description
M8030	PLC initializing	
M8031	Non-retentive register reset	When driving this M, ON/OFF mapping memory of Y, M, S, TC and the current values of T, C, D are all reset to be 0
M8032	Retentive register reset	
M8033	Registers keep stopping	When PLC changes from RUN to STOP, leave all content in mapping registers and data registers
M8034	All output forbidden	Set PC's all external contacts to be OFF status
M8038	Parameter setting	Set communication parameters flag

Stepping Ladder (M8041-M8046)

ID	Function	Description
M8041		
M8045	All output reset forbidden	When shifting the mode, all outputs reset functions are forbidden
M8046	STL status activate	When M8047 activating, act when any device of S0~S999 turns to be ON

Interruption (M8050-M8059)

ID	Function	Description
M8050 I000□	Forbid the input interruption 0	After executing EI instruction, even the interruption is allowed, but if M acts at this time, the correspond input interruption couldn't act separately E.g.: when M8050 is ON, interrupt I000□ is forbidden
M8051 I010□	Forbid the input interruption 1	
M8052 I020□	Forbid the input interruption 2	
M8053 I030□	Forbid the input interruption 3	
M8054 I040□	Forbid the input interruption 4	
M8055 I050□	Forbid the input interruption 5	
M8056 I40□□	Forbid the time interruption 0	After executing EI instruction, even the interruption is allowed, but if M acts at this time, the correspond time interruption couldn't act separately
M8057 I41□□	Forbid the time interruption 1	
M8058 I42□□	Forbid the time interruption 2	
M8059	Forbid the interruption	Forbid all interruption

Error Testing (M8067-M8072)

ID	Function	Description
M8067	Operation error	happen when calculating
M8070	Scan time out	
M8071	No user program	Internal codes parity error
M8072	User program error	execution codes or configure table parity error

Communication (M8120-M8148)

	ID	Function	Description
COM1	M8120		
	M8121	Waiting to send via RS232	
	M8122	“sending by RS232” flag	
	M8123	“RS232 receiving finish” flag	
	M8124	RS232 receiving flag	
	M8125	“Receive incomplete” flag	acceptance ends normally, but the accepted data number is less than the required number
	M8126	Global signal	
	M8127	“Accept error” flag	
	M8128	“ Accept correct” flag	
	M8129		
COM2	M8130		
	M8131	Waiting to send via RS232	
	M8132	“sending by RS232” flag	
	M8133	“RS232 receiving finish” flag	
	M8134	RS232 receiving flag	
	M8135	“Receive incomplete” flag	acceptance ends normally, but the accepted data number is less than the required number
	M8136	Global signal	
	M8137	“Accept error” flag	
	M8138	“ Accept correct” flag	
	M8139		
COM3	M8140		
	M8141	Waiting to send via RS232	
	M8142	“sending by RS232” flag	
	M8143	“RS232 receiving finish” flag	
	M8144	RS232 receiving flag	
	M8145	“Receive incomplete” flag	acceptance ends normally, but the accepted data number is less than the required number
	M8146	Global signal	
	M8147	“Accept error” flag	
	M8148	“ Accept correct” flag	
	M8149		

“High Speed Counter Interruption Finished” Flag (M8150-M 8169)

ID	Counter ID	Function	Description
M8150	C600	“Count Interruption Finished” Flag	Set flag ON when count interruption finish
M8151	C602	“Count Interruption Finished” Flag	Set flag ON when count interruption finish
M8152	C604	“Count Interruption Finished” Flag	Set flag ON when count interruption finish
M8153	C606	“Count Interruption Finished” Flag	Set flag ON when count interruption finish
M8154	C608	“Count Interruption Finished” Flag	Set flag ON when count interruption finish
M8155	C610	“Count Interruption Finished” Flag	Set flag ON when count interruption finish
M8156	C612	“Count Interruption Finished” Flag	Set flag ON when count interruption finish
M8157	C614	“Count Interruption Finished” Flag	Set flag ON when count interruption finish
M8158	C616	“Count Interruption Finished” Flag	Set flag ON when count interruption finish
M8159	C618	“Count Interruption Finished” Flag	Set flag ON when count interruption finish
M8160	C620	“Count Interruption Finished” Flag	Set flag ON when count interruption finish
M8161	C622	“Count Interruption Finished” Flag	Set flag ON when count interruption finish
M8162	C624	“Count Interruption Finished” Flag	Set flag ON when count interruption finish
M8163	C626	“Count Interruption Finished” Flag	Set flag ON when count interruption finish
M8164	C628	“Count Interruption Finished” Flag	Set flag ON when count interruption finish
M8165	C630	“Count Interruption Finished” Flag	Set flag ON when count interruption finish
M8166	C632	“Count Interruption Finished” Flag	Set flag ON when count interruption finish
M8167	C634	“Count Interruption Finished” Flag	Set flag ON when count interruption finish
M8168	C636	“Count Interruption Finished” Flag	Set flag ON when count interruption finish
M8169	C638	“Count Interruption Finished” Flag	Set flag ON when count interruption finish

Pulse output (M8170~M8238)

ID	Pulse ID	Function	specification
M8170	PULSE_1	“sending pulse” flag	Being ON when sending the pulse,
M8171		overflow flag of “32 bits pulse sending”	When overflow, Flag is on
M8172		Direction flag	1 is positive direction, the correspond direction port is on
M8173	PULSE_2	“sending pulse” flag	Being ON when sending the pulse,
M8174		overflow flag of “32 bits pulse sending”	When overflow, Flag is on
M8175		Direction flag	1 is positive direction, the correspond direction port is on
M8176	PULSE_3	“sending pulse” flag	Being ON when sending the pulse,
M8177		overflow flag of “32 bits pulse	When overflow, Flag is on

		sending”	
M8178		Direction flag	1 is positive direction, the correspond direction port is on
M8179	PULSE_4	“sending pulse” flag	Being ON when sending the pulse,
M8180		overflow flag of “32 bits pulse sending”	When overflow, Flag is on
M8181		Direction flag	1 is positive direction, the correspond direction port is on

Absolute, relative bit:

ID	function	specification	
M8190	C600 (24 segments)	1 is absolute, 0 is relative	
M8191	C602 (24 segments)	1 is absolute, 0 is relative	
M8192	C604 (24 segments)	1 is absolute, 0 is relative	
M8193	C606 (24 segments)	1 is absolute, 0 is relative	
M8194	C608 (24 segments)	1 is absolute, 0 is relative	
M8195	C610 (24 segments)	
M8196	C612 (24 segments)		
M8197	C614 (24 segments)		
M8198	C616 (24 segments)		
M8199	C618 (24 segments)		
M8200	C620 (24 segments)		
M8201	C622 (24 segments)		
M8202	C624 (24 segments)		
M8203	C626 (24 segments)		
M8204	C628 (24 segments)		
M8205	C630 (24 segments)		
M8206	C632 (24 segments)		
M8207	C634 (24 segments)		
M8208	C636 (24 segments)		
M8209	C638 (24 segments)		
M8210	Pulse alarm flag (frequency change suddenly)	1 is alarm, 0 is correct	PULSE_1
M8211	Neglect the alarm or not	When flag is 1, stop sending alarm	PULSE_1
M8212	Pulse alarm flag (frequency change suddenly)	1 is alarm, 0 is correct	PULSE_2
M8213	Neglect the alarm or not	When flag is 1, stop sending alarm	PULSE_2
M8214	Pulse alarm flag (frequency change suddenly)	1 is alarm, 0 is correct	PULSE_3
M8215	Neglect the alarm or not	When flag is 1, stop sending alarm	PULSE_3
M8216	Pulse alarm flag (frequency change suddenly)	1 is alarm, 0 is correct	PULSE_4

M8217	Neglect the alarm or not	When flag is 1, stop sending alarm	PULSE_4
M8218	Pulse alarm flag (frequency change suddenly)	1 is alarm, 0 is correct	PULSE_5
M8219	Neglect the alarm or not	When flag is 1, stop sending alarm	PULSE_5

Positive/negative count

ID	Counter Nr.	Function	Specification
M8238	C300~C498	Positive/negative counter control	0 is increment counter, 1 is decrement counter, default is 0

24 segments HSC interruption loop (M8270~M8289)

ID	Counter ID	Specification	
M8270	24 segments HSC interruption loop (C600)	if set it to be 1, then loop executing the interruption; or else execute only one time interruption;	
M8271	24 segments HSC interruption loop (C602)		
M8272	24 segments HSC interruption loop (C604)		
M8273	24 segments HSC interruption loop (C606)		
M8274	24 segments HSC interruption loop (C608)		
M8275	24 segments HSC interruption loop (C610)		
M8276	24 segments HSC interruption loop (C612)		
M8277	24 segments HSC interruption loop (C614)		
.....		
M8279	24 segments HSC interruption loop (C618)		
M8280	24 segments HSC interruption loop (C620)	if set it to be 1, then loop executing the interruption; or else execute only one time interruption;	
M8281	24 segments HSC interruption loop (C622)		
.....		
M8284	24 segments HSC interruption loop (C628)		
M8285	24 segments HSC interruption loop (C630)	if set it to be 1, then loop executing the interruption; or else execute only one time interruption;	
.....		
M8289	24 segments HSC interruption loop (C638)		

Read & Write the Expansions (M8340~M8341)

ID	Function	Specification
M8340	Read the expansion error flag (read instruction)	
M8341	Write the expansion error flag (write instruction)	

BLOCK Execution (M8630~M8730)

ID	Function	Specification
M8630		
M8631	BLOCK1 is running flag	
M8632	BLOCK2 is running flag	
.....
.....
.....
M8730	BLOCK100 is running flag	

Appendix 1-2. List of special memory and special data register**Clock (D8010-D8019)**

ID	Function	Specification
D8010	The current scan cycle	Unit:0.1ms
D8011	The min. scan time	Unit:0.1ms
D8012	The max. scan time	Unit:0.1ms
D8013	Second (clock)	0~59 (BCD code)
D8014	minute (clock)	0~59 (BCD code)
D8015	hour (clock)	0~23 (BCD code)
D8016	day (clock)	0~31 (BCD code)
D8017	month (clock)	0~12 (BCD code)
D8018	year (clock)	2000~2099 (BCD code)

D8019	week (clock)	0 (Sunday)~6 (Saturday) (BCD code)
-------	--------------	------------------------------------

Flag (D8021-D8029)

ID	Function	Specification
D8021	Model	Low byte
	Series number	High byte
D8022	Compatible system's version number	Low byte
	System's version number	High byte
D8023	Compatible model's version number	Low byte
	Model's version number	High byte
D8024	Model's information	Max 5 characters +“\0”
D8025		
D8026		
D8027		
D8028	Suitable program software version	
D8029		

Error check (D8067-D8098)

ID	Function	Specification
D8067	Operation error code's Nr.	The error of divide zero
D8068	lock the Nr. of error code	
D8069		
D8070	exceeded scan time	Unit 1ms
D8074	Nr. of offset registers D	
D8097		
D8098		

Communication (D8120-D8149)

Com 1	ID	Function	specification
	D8120		
	D8121		
	D8122	the left data RS232 should send	

	D8123	Data number RS232 received	
	D8126		
	D8127	Communication error code	7: hardware error 8: CRC Parity error 9: station number error 10: no start code 11: no end code 12: communication time out
	D8128	Modbus communication error (the replied message from slaves when the master send errors)	0: correct 1: don't support function ID 2: address error (overrun address) 3: Data error (the number of data) 8: saving data error (rewrite Flash)
	D8129		
Com2	D8130		
	D8131		
	D8132	the left data RS232 should send	
	D8133	Data number RS232 received	
	D8136		
	D8137	Communication error code	7: hardware error 8: CRC check error 9: station number error 10: no start sign 11: no end sign 12: communication time out
	D8138	Modbus communication error (the replied message from slaves when the master send errors)	0: correct 1: don't support function ID 2: address error(overrun address) 3: Data error (the number of data) 8: saving data error (rewrite Flash)
Com 3	D8139		
	D8140		
	D8141		
	D8142	the left data RS232 should send	
	D8143	Data number RS232 received	
	D8146		
	D8147	Communication error code	7: hardware error 8: CRC check error 9: station number error 10: no start sign 11: no end sign 12: communication time out

	D8148	Modbus communication error (the replied message from slaves when the master send errors)	0: correct 1: don't support function ID 2: address error(overrun address) 3: Data error (the number of data) 8: saving data error (rewrite Flash)
	D8149		

HSC Interruption Station (D8150-D8169)

ID	Counter ID	function	specification
D8150	C600	The current segment (No.n segment)	
D8151	C602	The current segment	
D8152	C604	The current segment	
D8153	C606	The current segment	
D8154	C608	The current segment	
D8155	C610	The current segment	
D8156	C612	The current segment	
D8157	C614	The current segment	
D8158	C616	The current segment	
D8159	C618	The current segment	
D8160	C620	The current segment	
D8161	C622	The current segment	
D8162	C624	The current segment	
D8163	C626	The current segment	
D8164	C628	The current segment	
D8165	C630	The current segment	
D8166	C632	The current segment	
D8167	C634	The current segment	
D8168	C636	The current segment	
D8169	C638	The current segment	

Pulse output (D8170-D8220)

ID	Pulse ID	function	specification
D8170	PULSE_1	The low 16 bits of accumulated pulse number	
D8171		The high 16 bits of accumulated pulse number	

D8172		The current segment (means Nr.n segment)	
D8173	PULSE_2	The low 16 bits of accumulated pulse number	
D8174		The high 16 bits of accumulated pulse number	
D8175		The current segment (means Nr.n segment)	
D8176	PULSE_3	The low 16 bits of accumulated pulse number	Only XC5-32RT-E (4PLS) model has
D8177		The high 16 bits of accumulated pulse number	
D8178		The current segment (means Nr.n segment)	
D8179	PULSE_4	The low 16 bits of accumulated pulse number	
D8180		The high 16 bits of accumulated pulse number	
D8181		The current segment (means Nr.n segment)	
D8190	PULSE_1	The low 16 bits of the current accumulated current pulse number	
D8191		The high 16 bits of the current accumulated current pulse number	
D8192	PULSE_2	The low 16 bits of the current accumulated current pulse number	
D8193		The high 16 bits of the current accumulated current pulse number	
D8194	PULSE_3	The low 16 bits of the current accumulated current pulse number	Only XC5-32RT-E (4PLS) model has
D8195		The high 16 bits of the current accumulated current pulse number	
D8196	PULSE_4	The low 16 bits of the current accumulated current pulse number	
D8197		The high 16 bits of the current accumulated current pulse number	

ID	Pulse ID	Function	Description
D8210	PULSE_1	Error segment number	PULSE_1
D8212	PULSE_2	Error segment number	PULSE_2
D8214	PULSE_3	Error segment number	PULSE_3
D8216	PULSE_4	Error segment number	PULSE_4
D8218	PULSE_5	Error segment number	PULSE_5
D8220	Frequency	indicate the bit Nr. Behind	

	Testing Precision	the decimal dot, 1 means * 10 , 2 means * 100	
--	-------------------	---	--

Absolute Positioning/Relative Positioning/the Origin Return (D8230-D8239)

ID	Pulse	Function	Description
D8230	PULSE_1	Rising time of the absolute/relation position instruction (Y0)	
D8231		Falling time of the origin return instruction (Y0)	
D8232	PULSE_2	Rising time of the absolute/relation position instruction (Y1)	
D8233		Falling time of the origin return instruction (Y1)	
D8234	PULSE_3	Rising time of the absolute/relation position instruction (Y2)	
D8235		Falling time of the origin return instruction (Y2)	
D8236	PULSE_4	Rising time of the absolute/relation position instruction (Y3)	
D8237		Falling time of the origin return instruction (Y3)	
D8238	PULSE_5	Rising time of the absolute/relation position instruction	
D8239		Falling time of the origin return instruction	

Read/Write the Expansion (D8315-D8316)

ID	Function	Description
D8315	Read the expansion's error type	
D8316	Write the expansion's error type	

Sequential Function Block (D8630-D8730)

ID	Function	Description
D8630		
D8631	The current executing instruction of BLOCK1	The value is used when BLOCK is monitoring
D8632	The current executing instruction of BLOCK2	The value is used when BLOCK is monitoring
.....
.....
.....
D8730	The current executing instruction of	The value is used when BLOCK is monitoring

	BLOCK100	
--	-----------------	--

Error information of the Expansions (D8600-D8627)

ID	Function	specification	Expansion ID
D8600	Read the expansion's error times		Expansion 1
D8601	Read the expansion's error	1. expansion's CRC parity error 2. expansion's address error 3. expansion's accepted data length error 4. expansion's accept buffer zone overflow 5. expansion's timeout error 6. CRC parity error when PLC is accepting data 7. unknown error	
D8602	write the expansion's error times		
D8603	write the expansion's error	
D8604	Read the expansion's times		Expansion 2
D8605	Read the expansion's error	
D8606	write the expansion's error times		
D8607	write the expansion's error	
D8608	Read the expansion's times		Expansion 3
D8609	Read the expansion's error	
D8610	write the expansion's error times		
D8611	write the expansion's error	
D8612	Read the expansion's times		Expansion 4
D8613	Read the expansion's error	
D8614	write the expansion's error times		
D8615	write the expansion's error	
.....
.....
D8624	Read the expansion's times		Expansion 7
D8625	Read the expansion's error	
D8626	write the expansion's error times		
D8627	write the expansion's error	

Appendix 1-3. ID List of the Expansions

Take the first expansion module as the example:

Channel	AD signal	DA signal	PID Output value	PID run/stop bit	Set value	PID parameter: Kp, Ki, Kd, control range Diff, Death range death
XC-E8AD						
0CH	ID100	-	ID108	Y100	QD100	Kp----QD108 Ki----QD109 Kd----QD110 Diff---QD111 Death--QD112
1CH	ID101	-	ID109	Y101	QD101	
2CH	ID102	-	ID110	Y102	QD102	
3CH	ID103	-	ID111	Y103	QD103	
4CH	ID104	-	ID112	Y104	QD104	
5CH	ID105	-	ID113	Y105	QD105	
6CH	ID106	-	ID114	Y106	QD106	
7CH	ID107	-	ID115	Y107	QD107	
XC-E4AD2DA						
0CH	ID100	-	ID104	Y100	QD102	Kp----QD106 Ki----QD107 Kd----QD108 Diff---QD109 Death--QD110
1CH	ID101	-	ID105	Y101	QD103	
2CH	ID102	-	ID106	Y102	QD104	
3CH	ID103	-	ID107	Y103	QD105	
0CH	-	QD100	-	-	-	
1CH	-	QD101	-	-	-	
XC-E4AD						
0CH	ID100	-	ID104	Y100	QD100	Kp----QD104 Ki----QD105 Kd----QD106 Diff---QD107 Death--QD108
1CH	ID101	-	ID105	Y101	QD101	
2CH	ID102	-	ID106	Y102	QD102	
3CH	ID103	-	ID107	Y103	QD103	

XC-E4DA

CH Nr.	Exp. 1	Exp. 2	Exp. 3	Exp. 4	Exp. 5	Exp. 6	Exp. 7
0CH	QD100	QD200	QD300	QD400	QD500	QD600	QD700
1CH	QD101	QD201	QD301	QD401	QD501	QD601	QD701
2CH	QD102	QD202	QD302	QD402	QD502	QD602	QD702
3CH	QD103	QD203	QD303	QD403	QD503	QD603	QD703

XC-E2DA

CH Nr.	Exp. 1	Exp. 2	Exp. 3	Exp. 4	Exp. 5	Exp. 6	Exp. 7
0CH	QD100	QD200	QD300	QD400	QD500	QD600	QD700
1CH	QD101	QD201	QD301	QD401	QD501	QD601	QD701

XC-E6PT-P/ XC-E6TC-P

CH Nr.	Current temp.	Set temp.	PID run/stop bit	The first 3CH PID value	The last 3CH PID value
0CH	ID100	QD100	Y100	Kp: QD106 Ki: QD107 Kd: QD108 Diff: QD109	Kp: QD110 Ki: QD111 Kd: QD112 Diff: QD113
1CH	ID101	QD101	Y101		
2CH	ID102	QD102	Y102		
3CH	ID103	QD103	Y103		
4CH	ID104	QD104	Y104		
5CH	ID105	QD105	Y105		

XC-E6TCA-P

RELATIVE PARAMETERS	COMMENTS AND DESCRIPTIONS				
	CH	Ch0	Ch1	Ch5
Display temperature (unit: 0.1°C)	module 1	ID100	ID101	ID10×	ID105
PID output (X input which returns to main unit)	module 1	X100	X101	X10×	X105
Thermocouple's connecting status (0 is connect, 1 is disconnect)	module 1	X110	X111	X11×	X115
PID auto tune error bit (0 is normal, 1 is parameters error)	module 1	X120	X121	X12×	X125
Enable channel's signal	module 1	Y100	Y101	Y10×	Y105
Auto tune PID control bit	Auto tune activate signal, enter auto tune stage if being set to be 1; When auto turn finish, PID parameters and temperature control cycle value are refreshed, reset this bit automatically. Users can also read its status; 1 represents auto tune processing; 0 represents no auto tune or auto tune finished				
PID output value (operation value)	Digital output value range: 0~4095 If PID output is analogue control (like steam valve open scale or thyistor ON angle), transfer this value to the analogue output module to realize the control requirements				
PID parameters (P、I、D)	Via PID auto tune to get the best parameters; If the current PID control can't fulfill the control requirements, users can also write the PID parameters according to experience. Modules carry on PID control according to the set PID parameters.				
PID operation range (Diff) (unit: 0.1°C)	PID operation activates between \pm Diff ranges. In real temperature control environments, if the temperature is lower than $T_{set\ temp.} - T_{Diff}$, PID output the max				

	value; if the temperature is higher than $T_{set\ temp.} + T_{Diff}$, PID output the mini value;
Temperature difference δ (unit: 0.1°C)	(sample temperature+ Temperature difference δ)/10=display temperature value. Then temperature display value can equal or close to the real temperature value. This parameter has sign (negative or positive). Unit is 0.1°C, the default value is 0.
The set temperature value(unit: 0.1°C)	Control system's target temperature value. The range is 0~1000°C, the precision is 0.1°C.
Temperature control cycle (unit: 0.1s)	Control cycle's range is 0.5s~200s, the minimum precision is 0.1s. The write value is the real temperature control cycle multiplies 10. i.e. 0.5s control cycle should write 5, 200s control cycle should write 2000.
Adjust environment temperature value (unit: 0.1°C)	If users think the environment temperature is different with the display temperature, he can write in the known temperature value. At the moment of value written in, calculate the temperature difference δ and save. Calculate the temperature difference value δ =adjust environment temperature value – sample temperature value. Unit: 0.1°C. E.g.: under heat balance status, user test the environmental temperature as 60.0°C with mercurial thermometer, the display temperature is 55.0°C (correspond sample temperature is 550), temperature difference δ =0. at this time, users write this parameters with 600, temperature difference δ is re-calculated to be 50 (5°C), then the display temperature = (sample temperature+temperature difference δ) /10 =60°C. **Note: when users write the adjust temperature value, make sure that the temperature is same with the environment temperature value. This value is very important, once it's wrong, temperature difference δ will be wrong, then effect the display temperature
Auto tune output value	The output when auto tune, use % as the unit, 100 represents 100% of full scale output. 80 represent 80% of full scale output.

XC-E3AD4PT2DA

CH Nr.	AD signal	PID output value	PID run/stop bit	Set value	PID parameters: Kp , Ki , Kd , control range Diff , death range Death
0CH	ID100	ID107	Y100	QD102	
1CH	ID101	ID108	Y101	QD103	Kp ----- QD109 Ki ----- QD110 Kd ----- QD111 Diff ----- QD112 Death ---- QD113
2CH	ID102	ID109	Y102	QD104	
CH Nr.	PT signal	PID output value	PID run/stop bit	Set value	
3CH	ID103	ID110	Y103	QD105	
4CH	ID104	ID111	Y104	QD106	
5CH	ID105	ID112	Y105	QD107	
6CH	ID106	ID113	Y106	QD108	

CH Nr.	DA signal	-	-	-	-
0CH	QD100	-	-	-	
1CH	QD101	-	-	-	

XC-E2AD2PT2DA

RELATIVE PARAMETERS	COMMENTS AND DESCRIPTIONS				
	CH	PT0 (0.01°C)	PT1 (0.01°C)	AD0	AD1
Display temperature (unit: 0.1°C)	module 1	ID100	ID101	ID102	ID103
PID output (X input which returns to main unit)	module 1	X100	X101	X102	X103
Connecting status (0 is connect, 1 is disconnect)	module 1	X110	X111	X112	X113
PID auto tune error bit (0 is normal, 1 is parameters error)	module 1	X120	X121	X122	X123a
Enable channel's signal	module 1	Y100	Y101	Y102	Y103
Auto tune PID control bit	Auto tune activate signal, enter auto tune stage if being set to be 1; when auto turn finish, PID parameters and temperature control cycle value are refreshed, reset this bit automatically. Users can also read its status; 1 represents auto tune processing; 0 represents no atto tune or auto tune finished				
PID output value (operation value)	Digital output value range: 0~4095 If PID output is analogue control (like steam valve open scale or thyistor ON angle), transfer this value to the analogue output module to realize the control requirements				
PID parameters (P、I、D)	Via PID auto tune to get the best parameters; If the current PID control can't fulfill the control requirements, users can also write the PID parameters according to experience. Modules carry on PID control according to the set PID parameters.				
PID operation range (Diff) (unit: 0.1°C)	PID operation activates between \pm Diff ranges. In real temperature control environments, if the temperature is lower than $T_{set\ temp.} - T_{Diff}$, PID output the max value; if the temperature is higher than $T_{set\ temp.} + T_{Diff}$, PID output the mini value;				
Temperature difference δ	(sample temperature+ Temperature difference δ)/10=display temperature value. Then temperature display value can equal or close to the real temperature value. This parameter				

(unit: 0.1°C)	has sign (negative or positive). Unit is 0.1°C, the default value is 0.
The set temperature value(unit: 0.1°C)	Control system's target temperature value. The range is 0~1000°C, the precision is 0.1°C.
Temperature control cycle (unit: 0.1s)	Control cycle's range is 0.5s~200s, the minimum precision is 0.1s. The write value is the real temperature control cycle multiplies 10. i.e. 0.5s control cycle should write 5, 200s control cycle should write 2000.
Real value (unit: 0.1°C)	<p>If users think the environment temperature is different with the display temperature, he can write in the known temperature value. At the moment of value written in, calculate the temperature difference δ and save.</p> <p>Calculate the temperature difference value $\delta = \text{adjust environment temperature value} - \text{sample temperature value}$. Unit: 0.1°C.</p> <p>E.g.: under heat balance status, user test the environmental temperature as 60.0°C with mercurial thermometer, the display temperature is 55.0°C (correspond sample temperature is 550), temperature difference $\delta = 0$. at this time, users write this parameters with 600, temperature difference δ is re-calculated to be 50 (5°C), then the display temperature = $(\text{sample temperature} + \text{temperature difference } \delta) / 10 = 60^\circ\text{C}$.</p> <p>**Note: when users write the adjust temperature value, make sure that the temperature is same with the environment temperature value. This value is very important, once it's wrong, temperature difference δ will be wrong, then effect the display temperature</p>
Auto tune output value	The output when auto tune, use % as the unit, 100 represents 100% of full scale output. 80 represent 80% of full scale output.

Appendix 1-4. Special Flash Register List

1、 I filter

ID	Function	Initial Value	Description
FD8000	input filter time of X port	10	Unit: ms
FD8002		0	
FD8003		0	
.....		0	
FD8009		0	

2、 I mapping

ID	Function	Initial value	Description
FD8010	X00 corresponds with I**	0	X0 corresponds with number of input image I**
FD8011	X01 corresponds with I**	1	Initial values are all decimal
FD8012	X02 corresponds with I**	2	
.....		
FD8073	X77 corresponds with I**	63	

3、 O mapping

ID	Function	Initial value	Description
FD8074	Y00 corresponds with I**	0	Y0 corresponds with the number of output image O**
FD8075	Y01 corresponds with I**	1	Initial value are all decimal
FD8076	Y02 corresponds with I**	2	
.....		
FD8137	Y77 corresponds with I**	63	

4、 I property

ID	function	Initial value	Description
FD8138	X00 property	all be 0	0: positive logic; others: negative logic
FD8139	X01 property		
FD8140	X02 property		
.....		
FD8201	X77 property		

5、 power-off retentive area of soft components

	Soft component	FD REGISTER	FUNCTION	Default value	Power-off retentive range
XC1 series	D	FD8202	Start tag of D power off retentive area	100	D100~D149
	M	FD8203	Start tag of M power off retentive area	200	M200~M319
	T	FD8204	Start tag of T power off retentive area	640	-
	C	FD8205	Start tag of C power off retentive area	320	C320~C631
	S	FD8206	Start tag of S power off retentive area	512	-
XC2 series	D	FD8202	Start tag of D power off retentive area	4000	D4000~D4999
	M	FD8203	Start tag of M power off retentive area	3000	M3000~M7999
	T	FD8204	Start tag of T power off retentive area	640	-
	C	FD8205	Start tag of C power off retentive area	320	C320~C639
	S	FD8206	Start tag of S power off retentive area	512	S512~S1023

XC3 series	D	FD8202	Start tag of D power off retentive area	4000	D4000~D7999
	M	FD8203	Start tag of M power off retentive area	3000	M3000~M7999
	T	FD8204	Start tag of T power off retentive area	640	-
	C	FD8205	Start tag of C power off retentive area	320	C320~C639
	S	FD8206	Start tag of S power off retentive area	512	S512~S1023
	ED	FD8207	Start tag of ED power off retentive area	0	ED0~ED16383
XC5 series	D	FD8202	Start tag of D power off retentive area	4000	D4000~D7999
	M	FD8203	Start tag of M power off retentive area	4000	M4000~M7999
	T	FD8204	Start tag of T power off retentive area	640	-
	C	FD8205	Start tag of C power off retentive area	320	C320~C639
	S	FD8206	Start tag of S power off retentive area	512	S512~S1023
	ED	FD8207	Start tag of ED power off retentive area	0	ED0~ED36863
XCM series	D	FD8202	Start tag of D power off retentive area	4000	D4000~D4999
	M	FD8203	Start tag of M power off retentive area	3000	M3000~M7999
	T	FD8204	Start tag of T power off retentive area	640	-
	C	FD8205	Start tag of C power off retentive area	320	C320~C639
	S	FD8206	Start tag of S power off retentive area	512	S512~S1023
	ED	FD8207	Start tag of ED power off retentive area	0	ED0~ED36863

6、Communication

	ID	Function	Initial	Description
COM1	FD8210	Communicate Mode (station number)	1	255 (FF) is free mode, 1~254 is modbus station number
	FD8211	Communicate format	8710	Baud rate, Data bit, stop bit, parity
	FD8212	Judgment time of ASC timeout	3	Unit ms, if set to be 0, it means no timeout waiting
	FD8213	Judgment time of reply timeout	300	Unit ms, if set to be 0, it means no timeout waiting
	FD8214	Start ASC	0	High 8 bits invalid
	FD8215	End ASC	0	High 8 bits invalid
	FD8216	Free format setting	0	8/16 bits buffer; With/without start bit, With/without stop bit
COM2	FD8220	Communicate Mode (station number)	8710	255 (FF) is free mode, 1~254 is modbus station number
	FD8221	Communicate format	3	Baud rate, Data bit, stop bit, parity
	FD8222	Judgment time of ASC timeout	300	Unit ms, if set to be 0, it means no timeout waiting
	FD8223	Judgment time of reply timeout	0	Unit ms, if set to be 0, it means no timeout waiting
	FD8224	Start ASC	0	High 8 bits invalid
	FD8225	End ASC	0	High 8 bits invalid
	FD8226	Free format setting	8710	8/16 bits buffer; With/without start bit, With/without stop bit
COM3	FD8230	Communicate Mode (station number)	8710	255 (FF) is free mode, 1~254 is modbus station number
	FD8231	Communicate format	3	Baud rate, Data bit, stop bit, parity
	FD8232	Judgment time of ASC timeout	300	Unit ms, if set to be 0, it means no timeout waiting
	FD8233	Judgment time of reply timeout	0	Unit ms, if set to be 0, it means no timeout waiting
	FD8234	Start ASC	0	High 8 bits invalid
	FD8235	End ASC	0	High 8 bits invalid
	FD8236	Free format setting	8710	8/16 bits buffer; With/without start bit, With/without stop bit

※1: If you change special FLASH memory, it will take into effect after restart the PLC

Appendix 2 Instructions List

In this chapter, we will list all the instructions XC series PLC support. These instructions include: basic instructions, application instructions, special function instructions and motion control instructions. Also, we declare each instruction's application range.

This part enables the users to check the instruction's functions much faster. For the detailed application, please refer to XC Series Programmable Controller **【Instruction Part】** .

Appendix 2-1. Basic Instructions List

Appendix 2-2. Application Instructions List

Appendix 2-3. Special Function Instructions List

Appendix 2-4. Motion Control Instructions List

Appendix 2-1. Basic Instructions List

Mnemonic	Function
LD	Initial logical operation contact type NO (normally open)
LDI	Initial logical operation contact type NC (normally closed)
OUT	Final logic operation type coil drive
AND	Serial connection of NO
ANI	Serial connection of NC
OR	Parallel connection of NO
ORI	Parallel connection of NC
LDP	Rising edge pulse
LDF	Falling edge pulse
ANDP	Serial connection of rising edge pulse
ANDF	Serial connection of falling edge pulse
ORP	Parallel connection of rising edge pulse
ORF	Parallel connection of falling edge pulse
LDD	Read the point
LDDI	Read NC
ANDD	Read the point and serial connection
ANDDI	Read NC and serial connection
ORD	Read the point and parallel connection
ORDI	Read NC and parallel connection
OUTD	Output the point
ORB	Parallel connection of parallel multiply parallel circuit
ANB	Serial connection of parallel multiply parallel circuit
MCS	New bus line start
MCR	Bus line return
ALT	Alternate state
PLS	Rising edge pulse
PLF	Falling edge pulse
SET	Set a bit device permanently on
RST	Reset a bit device permanently off
OUT	Output counter coil
RST	Output reset, and current data reset to zero
END	I/O process and return to step0
GROUP	Instruction block fold start
GROUPE	Instruction block fold end
TMR	Time

Appendix 2-2. Applied instruction list

Sort	Mnemonic	Function	Suit Model				
			XC1	XC2	XC3	XC5	XCM
Program flow	CJ	Condition Jump	√	√	√	√	√
	CALL	Call subroutine	√	√	√	√	√
	SRET	Subroutine return	√	√	√	√	√
	STL	Flow start	√	√	√	√	√
	STLE	Flow end	√	√	√	√	√
	SET	Open the assigned flow, close the current flow	√	√	√	√	√
	ST	Open the assigned flow, not close the current flow	√	√	√	√	√
	FOR	Start of a FOR-NEXT loop	√	√	√	√	√
	NEXT	END of a FOR-NEXT loop	√	√	√	√	√
	FEND	End of main program	√	√	√	√	√
Data compare	LD= ^{*1}	LD activate if (S1)= (S2)	√	√	√	√	√
	LD>> ^{*1}	LD activate if (S1)> (S2)	√	√	√	√	√
	LD< ^{*1}	LD activate if (S1)< (S2)	√	√	√	√	√
	LD<> ^{*1}	LD activate if(S1)≠(S2)	√	√	√	√	√
	LD>= ^{*1}	LD activate if(S1) >= (S2)	√	√	√	√	√
	LD<= ^{*1}	LD activate if(S1) <= (S2)	√	√	√	√	√
	AND= ^{*1}	AND activate if (S1)= (S2)	√	√	√	√	√
	AND> ^{*1}	AND activate if (S1)> (S2)	√	√	√	√	√
	AND< ^{*1}	AND activate if (S1)< (S2)	√	√	√	√	√
	AND<> ^{*1}	AND activate if(S1)≠(S2)	√	√	√	√	√
	AND>= ^{*1}	AND activate if(S1) >= (S2)	√	√	√	√	√
	AND<= ^{*1}	AND activate if(S1) <= (S2)	√	√	√	√	√
	OR= ^{*1}	OR activate if (S1)= (S2)	√	√	√	√	√
	OR> ^{*1}	OR activate if (S1)> (S2)	√	√	√	√	√
	OR< ^{*1}	OR activate if (S1)< (S2)	√	√	√	√	√
	OR<> ^{*1}	OR activate if(S1)≠(S2)	√	√	√	√	√
OR>= ^{*1}	OR activate if(S1) >= (S2)	√	√	√	√	√	
OR<= ^{*1}	OR activate if(S1) <= (S2)	√	√	√	√	√	
Data move	CMP ^{*1}	Data compare	√	√	√	√	√
	ZCP ^{*1}	Data zone compare	√	√	√	√	√
	MOV ^{*1}	Move	√	√	√	√	√
	BMOV	Block move	√	√	√	√	√
	FMOV ^{*1}	Fill move	√	√	√	√	√
	FWRT ^{*1}	FlashROM Written	√	√	√	√	√
	MSET	Zone set	√	√	√	√	√
	ZRST	Zone reset	√	√	√	√	√
	SWAP	The high bytes and low bytes exchange	√	√	√	√	√
XCH ^{*1}	Data exchange	√	√	√	√	√	

Sort	Mnemonic	function	Suit model				
			XC1	XC2	XC3	XC5	XCM
Data Operation	ADD ^{*1}	addition	√	√	√	√	√
	SUB ^{*1}	subtraction	√	√	√	√	√
	MUL ^{*1}	multiplication	√	√	√	√	√
	DIV ^{*1}	division	√	√	√	√	√
	INC ^{*1}	Increment	√	√	√	√	√
	DEC ^{*1}	decrement	√	√	√	√	√
	MEAN ^{*1}	mean	√	√	√	√	√
	WAND ^{*1}	Word and	√	√	√	√	√
	WOR ^{*1}	Word or	√	√	√	√	√
	WXOR ^{*1}	Word exclusive or	√	√	√	√	√
	CML ^{*1}	Complement	√	√	√	√	√
NEG ^{*1}	Negative	√	√	√	√	√	
Data shift	SHL ^{*1}	Arithmetic shift left		√	√	√	√
	SHR ^{*1}	Arithmetic shift right		√	√	√	√
	LSL ^{*1}	Logic shift left		√	√	√	√
	LSR ^{*1}	Logic shift right		√	√	√	√
	ROL ^{*1}	Rotation shift left		√	√	√	√
	ROR ^{*1}	Rotation shift right		√	√	√	√
	SFTL ^{*1}	Bit shift left		√	√	√	√
	SFTR ^{*1}	Bit shift right		√	√	√	√
	WSFL	Word shift left		√	√	√	√
	WSFR	Word shift right		√	√	√	√
Data convert	WTD	Single word integer convert to double word integer		√	√	√	√
	FLT ^{*1}	16 bits integer convert to float		√	√	√	√
	FLTD ^{*1}	64 bits integer convert to float		√	√	√	√
	INT ^{*1}	Float convert to integer		√	√	√	√
	BIN	BCD convert to binary		√	√	√	√
	BCD	Binary convert to BCD		√	√	√	√
	ASCI	Hex convert to ASC II		√	√	√	√
	HEX	ASC II convert to Hex		√	√	√	√
	DECO	Coding		√	√	√	√
	ENCO	High bit coding		√	√	√	√
ENCOL	Low bit coding		√	√	√	√	

Sort	Mnemonic	function	Suit Model				
			XC1	XC2	XC3	XC5	XCM
Float Operation	ECMP ^{※2}	Float compare		√	√	√	√
	EZCP ^{※2}	Float zone compare		√	√	√	√
	EADD ^{※2}	Float addition		√	√	√	√
	ESUB ^{※2}	Float subtraction		√	√	√	√
	EMUL ^{※2}	Float multiplication		√	√	√	√
	EDIV ^{※2}	Float division		√	√	√	√
	ESQR ^{※2}	Float square root		√	√	√	√
	SIN ^{※2}	Sine		√	√	√	√
	COS ^{※2}	Cosine		√	√	√	√
	TAN ^{※2}	tangent		√	√	√	√
	ASIN ^{※2}	Float arcsin		√	√	√	√
	ACOS ^{※2}	Float arccos		√	√	√	√
	ATAN ^{※2}	Float arctan		√	√	√	√
Clock	TRD	Read RTC data		√	√	√	√
	TWR	Set RTC data		√	√	√	√

※1: All the instructions are 16bits except the instructions with ※1 which has 32bits. 32bits instructions are added D in front of its 16bits instruction. Such as ADD (16bits) / DADD (32bits).

※2: These instructions are 32bits, and have no 16bits format.

※3: √ means this series support the instruction.

Appendix 2-3. Special Instructions List

Sort	Mnemonic	Function	Suitable type				
			XC1	XC2	XC3	XC5	XCM
pulse	PLSY ^{※1}	Single segment no accelerate/decelerate pulse output		√	√	√	√
	PLSR ^{※1}	Relative position multi-segment pulse control		√	√	√	√
	PLSF ^{※1}	Changeable frequency pulse output		√	√	√	√
	PLSA ^{※1}	Absolute position multi-segment pulse control		√	√	√	√
	PLSNE XT/PLS NT	change the pulse segment		√	√	√	√
	PLSMV ^{※2}	Save the pulse number in the register		√	√	√	√
	STOP	Pulse stop		√	√	√	√
High Speed Counter (HSC)	HSCR ^{※2}	Read high speed counter value		√	√	√	√
	HSCW ^{※2}	Write high speed counter value		√	√	√	√

MODBUS communication	COLR	MODBUS coil read		√	√	√	√
	INPR	MODBUS input coil read		√	√	√	√
	COLW	MODBUS single coil write		√	√	√	√
	MCLW	MODBUS multi coil write		√	√	√	√
	REGR	MODBUS register read		√	√	√	√
	INRR	MODBUS input register write		√	√	√	√
	REGW	MODBUS single register write		√	√	√	√
	MRGW	MODBUS multi register write		√	√	√	√
Free format communication	SEND	Free format data send		√	√	√	√
	RCV	Free format data receive		√	√	√	√
CANBUS communication	CCOLR	CANBUS coil read				√	
	CCOLW	CANBUS coil write				√	
	CREGR	CANBUS register read				√	
	CREGW	CANBUS register write				√	
Precision time	STR	Precision time		√	√	√	√
	STRR	Read precision time register		√	√	√	√
	STRS	Stop precision time		√	√	√	√
interrupt	EI	Enable interruption		√	√	√	√
	DI	Disable interruption		√	√	√	√
	IRET	Interruption return		√	√	√	√
BLOCK	BSTOP	Stop the block		√	√	√	√
	BGOON	Continue running the block		√	√	√	√
	WAIT	Wait		√	√	√	√
Read/write expansion	FROM	Read the module		√	√	√	√
	TO	Write the module		√	√	√	√
others	FRQM	Frequency measurement		√	√	√	√
	PWM	Pulse width modulation		√	√	√	√
	PID	PID control		√	√	√	√

※1: All the instructions are 16bits except the instructions with ※1 which has 32bits. 32bits instructions are added D in front of its 16bits instruction. Such as ADD (16bits) / DADD (32bits).

※2: These instructions are 32bits, and have no 16bits format.

※3: √ means this series support the instruction.

Appendix 2-4. MOTION CONTROL INSTRUCTIONS LIST

Mnemonic	FUNCTION	SUITABLE MODELS				
		XC1	XC2	XC3	XC5	XCM
ZRN ^{※1}	Origin return					√
DRVA ^{※1}	Absolute position					√
DRVI ^{※1}	Relative position					√
ABS	Absolute address					√
CCW ^{※2}	Circular anticlockwise interpolation					√

CHK	Servo end check					√
CW ^{※2}	Circular interpolation clockwise					√
DRV ^{※2}	High speed					√
DRVR	Electrical zero return					√
DRVZ	Machine zero return					√
FOLLOW ^{※2}	Follow movement instruction					√
INC	Incremental address					√
LIN ^{※2}	Linear interpolation positioning					√
PLAN ^{※2}	Plane selection					√
TIM ^{※2}	Delayed time					√
SETR	Set electrical zero					√
SETP ^{※2}	Set reference frame					√

※1: The instructions with ※1 sign have 32 bits form; generally 32 bits instructions are represented as adding D before 16 bits instructions, like this 32 bits ADD instructions is DADD;

※2: The instructions with ※2 sign are 32 bits form; they don't have 16 bits form;

Appendix 3 Version for special function

Generally, the functions and instructions described in this manual don't have software and hardware requirements. But for some special functions, we have software and hardware versions requirement. Below, we list these requirements for the special functions;

function	Hardware version	Software version
Fill move 32 bits instruction DFMOV	V3.0 and above	V3.0 and above
Float number move instruction EMOV	V3.0 and above	V3.0 and above
Gray code switch to binary instruction GRY, GBIN	V3.3 and above	V3.3 and above
Anti-trigonometric Operation	V3.0 and above	V3.0 and above
Read/write clock	V2.51 and above	V3.0 and above
Read/write high speed counter	V3.1c and above	V3.0 and above
Interrupt high speed counter	V3.1c and above	V3.0 and above
Pulse output PTO, PTOA, PSTOP, PTF	V3.3 and above	V3.3 and above
Free format instruction RCVST	V3.1e and above	V3.1f and above
Read precise time	V3.0e and above	V3.0 and above
Stop precise time	V3.0e and above	V3.0 and above
C program block function	V3.0c and above	V3.0 and above
PID function	V3.0 and above	V3.0 and above
Block	V3.1i and above	V3.1h and above
Connect T-BOX	V3.0g and above	V3.0 and above
Connect G-BOX	V3.0i and above	V3.0 and above
Connect XC-SD-BD	V3.2 and above	V3.2 and above
Read/write XC-E6TCA-P, XC-E2AD2PT3DA, XC-E2AD2PT2DA	V3.1f and above	V3.1b and above
Expand register ED	V3.0 and above	V3.0 and above

Appendix 4 PLC Configuration List

This part is used to check each model's configurations. Via this table, we can judge the model easily;

○ selectable ×Not support √support

Models	clock	communication			expansion	BD board	NO. of high speed counter			No. of Pulse (T model/RT model)	External interrupt
		CAN	Modbus	Free			Increase	Pulse + director	AB phase		
XC1 Series											
XC1-10	×	×	×	×	×	×	×	×	×	×	×
XC1-16	×	×	×	×	×	×	×	×	×	×	×
XC1-24	×	×	√*2	×	×	×	×	×	×	×	×
XC1-32	×	×	√*2	×	×	×	×	×	×	×	×
XC2 Series											
XC2-14	○	×	○	○	×	×	5	2	2	2	3
XC2-16	○	×	×	×	×	×	5	2	2	2	3
XC2-24	○	×	√	√	×	√	5	2	2	2*1	3
XC2-32	○	×	√	√	×	√	5	2	2	2*1	3
XC2-48	○	×	√	√	×	√	5	2	2	2*1	3
XC2-60	○	×	√	√	×	√	5	2	2	2*1	3
XC3 Series											
XC3-14	×	×	○	○	×	×	4	2	2	2	1
XC3-24	○	×	√	√	√	√	6	3	3	2*1	3
XC3-32	○	×	√	√	√	√	6	3	3	2*1	3
XC3-42	○	×	√	√	√	×	6	3	3	2*1	3
XC3-48	○	×	√	√	√	√	4	2	2	2	3
XC3-60	○	×	√	√	√	√	4	2	2	2	3
XC3-19A R-E	○	×	√	√	×	×	4	2	2	2	3
XC5 Series											
XC5-24	○	×	√	√	√	√	2	1	1	4*1	5
XC5-32	○	×	√	√	√	√	2	1	1	4*1	5
XC5-48	○	√	√	√	√	√	6	3	3	2*1	3
XC5-60	○	√	√	√	√	√	6	3	3	2*1	3
XCM Series											
XCM-24/ 32T4	○	×	√	√	√	√	2	1	1	4*1	5

Appendix 3 version for special function

XCM-24/ 32T3	○	×	√	√	√	√	4	2	2	3 ^{※1}	3
XCM-60	○	×	√	√	×	√	4	0	3	10 ^{※1}	4
XCC Series											
XCC-32	○	√	√	√	√	√	5	0	5	5	5

※1: If use BD board, Y1 can't be used for pulse

※2: it just can be used for Modbus slave.

Appendix 5 common question A&Q

The following are the common questions may happen when using the PLC.

Q1: why the coil is not set when the condition is satisfied?

A1: the probable reasons:

- (1) use one coil for many times, double coils output, the later coil has priority.
- (2) some conditions reset the coil, please use monitor function to find the reset point and modify the program.

Q2: set on the pulse output instruction, the pulse doesn't output?

A2: there are many pulse output instructions in the program.

Q3: why connect the high speed counter but no counter value?

A3: the probable reasons:

- (1) make sure the PLC has high speed counter photo-couplers.
- (2) when the PLC hardware version is 2.5 and software version is 3.0, it is not available to use HSC, please update the hardware version to 3.0.

Q4: What's the difference between com1 and com2?

A4: the communication parameters of com1 and com2 can set by users. The difference is com1 can return to default parameters by stop PLC after power on.

Q5: Why free format communication is failure?

A5: check the communication parameters, if use com2, please set the FD8220 to HFF, FD8221 set to corresponding parameters.

Q6: Why the real time clock (RTC) cannot work

A6: XC3-14 and XP1 do not have RTC function.

Q7: Why PLC cannot communicate with other device

A7: the probable reasons:

- (1) Communication parameters: PLC com port and device parameters must be the same.
- (2) Communication cable: Make sure connection is correct and good.
- (3) Communication serial port: check the serial port, download the PLC program, if download successful the serial port is no problem.
- (4) Ask manufacturer for help.

Q8: How long can the PLC battery are used?

A8: for 3-5 years.

Q9: why the temperature fluctuates serious under normal temperature when connecting the thermocouple with the temperature module?

A9: the probable reasons:

- (1) Check if the thermocouple cold point is short with the outside cover. If short, please change another thermocouple.
- (2) the weak electricity such as outside interference, thermocouple, temperature module should separate from the strong electricity, make sure there is certain distance between them. If the device has motor, inverter, make sure to connect the ground correctly.

The logo for XINJE, featuring the word "XINJE" in a bold, blue, sans-serif font. The letter "X" is stylized with a diagonal slash through it.

XINJE Electric Co., Ltd.

4th Floor, Building 7th, No.100 Dicui Rd,
Wuxi, China

Tel: 86-0510-85134139

Fax: 86-0510-85111290

www.xinje.com

Email: cheerfiona@gmail.com