



# **XC series PLC**

**User manual [Instruction]**

XINJE Electric Co., Ltd.

No.PC01 20110106 3.3

---

# Catalog

|  |           |
|--|-----------|
| <b>1 PROGRAM SUMMARY .....</b>                                   | <b>8</b>  |
| 1-1. PROGRAM CONTROLLER FEATURES.....                            | 9         |
| 1-2. PROGRAM LANGUAGE .....                                      | 10        |
| 1-2-1. Type .....  | 10        |
| 1-2-2. Alternation.....  | 11        |
| 1-3. PROGRAM FORMAT.....   | 11        |
| <b>2 SOFT COMPONENT' S FUNCTION .....</b>                        | <b>13</b> |
| 2-1. SUMMARY OF THE SOFT COMPONENTS .....                        | 14        |
| 2-2. STRUCTURE OF SOFT COMPONENTS.....                           | 17        |
| 2-2-1. Structure of Memory.....                                  | 17        |
| 2-2-2. Structure of Bit Soft Components.....                     | 19        |
| 2-3. SOFT COMPONENTS LIST .....                                  | 20        |
| 2-3-1. Soft Components List.....                                 | 20        |
| 2-3-2. Power off Retentive Zone.....                             | 27        |
| 2-4. INPUT/OUTPUT RELAYS (X, Y).....                             | 29        |
| 2-5. AUXILIARY RELAY (M).....                                    | 31        |
| 2-6. STATUS RELAY (S).....                                       | 33        |
| 2-7. TIMER (T).....  | 34        |
| 2-8. COUNTER (C).....  | 36        |
| 2-9. DATA REGISTER (D).....                                      | 40        |
| 2-10. CONSTANT .....   | 42        |
| 2-11. PROGRAM PRINCIPLE .....                                    | 43        |
| <b>3 BASIC PROGRAM INSTRUCTIONS.....</b>                         | <b>48</b> |
| 3-1. BASIC INSTRUCTIONS LIST.....                                | 50        |
| 3-2. [LD], [LDI], [OUT].....                                     | 53        |
| 3-3. [AND], [ANI] .....  | 54        |
| 3-4. [OR], [ORI] .....   | 55        |
| 3-5. [LDP], [LDF], [ANDP], [ANDF], [ORP], [ORF].....             | 56        |
| 3-6. [LDD], [LDDI], [ANDD], [ANDDI], [ORD], [ORDI], [OUTD] ..... | 57        |
| 3-7. [ORB] .....   | 58        |
| 3-8. [ANB].....  | 59        |
| 3-9. [MCS], [MCR].....   | 60        |
| 3-10. [ALT] .....  | 61        |
| 3-11. [PLS], [PLF] .....   | 62        |
| 3-12. [SET], [RST].....  | 63        |
| 3-13. <b>【OUT】</b> , <b>【RST】</b> FOR THE COUNTERS.....          | 64        |
| 3-14. [END].....   | 65        |
| 3-15. [GROUP], [GROUPE] .....                                    | 66        |
| 3-16. ITEMS TO NOTE WHEN PROGRAMMING.....                        | 67        |
| <b>4 APPLIED INSTRUCTIONS.....</b>                               | <b>68</b> |

---

|   |     |
|---|-----|
| 4-1. APPLIED INSTRUCTION LIST.....                                      | 69  |
| 4-2. READING METHOD OF APPLIED INSTRUCTIONS .....                       | 74  |
| 4-3. PROGRAM FLOW INSTRUCTIONS.....                                     | 76  |
| 4-3-1. Condition Jump [CJ].....   | 77  |
| 4-3-2. Call subroutine [CALL] and Subroutine return [SRET] .....        | 78  |
| 4-3-3. Flow [SET]. [ST]. [STL]. [STLE] .....                            | 79  |
| 4-3-4. [FOR] and [NEXT] .....   | 81  |
| 4-3-5. [FEND] and [END].....  | 83  |
| 4-4. DATA COMPARE FUNCTION.....   | 84  |
| 4-4-1. LD Compare [LD □] .....  | 84  |
| 4-4-2. AND Compare [AND □].....   | 86  |
| 4-4-3. Parallel Compare [OR □] .....                                    | 87  |
| 4-5. DATA MOVE .....  | 88  |
| 4-5-1. Data Compare [CMP].....  | 89  |
| 4-5-2. Data zone compare [ZCP] .....                                    | 90  |
| 4-5-3. MOV [MOV] .....  | 91  |
| 4-5-4. Data block Move [BMOV].....                                      | 93  |
| 4-5-5. Data block Move [PMOV].....                                      | 94  |
| 4-5-6. Fill Move [FMOV] .....   | 95  |
| 4-5-7. FlashROM Write [FWRT].....                                       | 98  |
| 4-5-8. Zone set [MSET] .....  | 99  |
| 4-5-9. Zone reset [ZRST] .....  | 100 |
| 4-5-10. Swap the high and low byte [SWAP].....                          | 101 |
| 4-5-11. Exchange [XCH] .....  | 102 |
| 4-5-12. Floating move [EMOV].....                                       | 103 |
| 4-6. DATA OPERATION INSTRUCTIONS .....                                  | 104 |
| 4-6-1 Addition [ADD].....   | 104 |
| 4-6-2. Subtraction [SUB].....   | 105 |
| 4-6-3. Multiplication [MUL].....  | 107 |
| 4-6-4. Division [DIV] .....   | 108 |
| 4-6-5. Increment [INC] & Decrement [DEC].....                           | 110 |
| 4-6-6. Mean [MEAN].....   | 111 |
| 4-6-7. Logic AND [WAND], Logic OR [WOR], Logic Exclusive OR [WXOR]..... | 112 |
| 4-6-8. Converse [CML] .....   | 114 |
| 4-6-9. Negative [NEG].....  | 115 |
| 4-7. SHIFT INSTRUCTIONS .....   | 116 |
| 4-7-1. Arithmetic shift left [SHL], Arithmetic shift right [SHR].....   | 116 |
| 4-7-2. Logic shift left [LSL], Logic shift right [LSR] .....            | 118 |
| 4-7-3. Rotation shift left [ROL], Rotation shift right [ROR].....       | 119 |
| 4-7-4. Bit shift left [SFTL] .....                                      | 120 |
| 4-7-5. Bit shift right [SFTR].....                                      | 122 |
| 4-7-6. Word shift left [WSFL].....                                      | 123 |
| 4-7-7. Word shift right [WSFR].....                                     | 124 |
| 4-8. DATA CONVERT .....   | 125 |

---

|   |            |
|---|------------|
| 4-8-1. Single word integer converts to double word integer [WTD]..... | 126        |
| 4-8-2. 16 bits integer converts to float point [FLT].....             | 127        |
| 4-8-3. Float point converts to integer [INT].....                     | 128        |
| 4-8-4. BCD convert to binary [BIN].....                               | 129        |
| 4-8-5. Binary convert to BCD [BCD].....                               | 130        |
| 4-8-6. Hex. Converts to ASCII [ASCII].....                            | 131        |
| 4-8-7. ASCII converts to hex. [HEX].....                              | 132        |
| 4-8-8. Coding [DECO].....   | 133        |
| 4-8-9. High bit coding [ENCO].....                                    | 135        |
| 4-8-10. Low bit coding [ENCOL].....                                   | 136        |
| <b>4-9. FLOATING OPERATION</b> .....                                  | <b>138</b> |
| 4-9-1. Float Compare [ECMP].....                                      | 139        |
| 4-9-2. Float Zone Compare [EZCP].....                                 | 140        |
| 4-9-3. Float Add [EADD].....  | 141        |
| 4-9-4. Float Sub [ESUB].....  | 142        |
| 4-9-5. Float Mul[EMUL].....   | 144        |
| 4-9-6. Float Div [EDIV].....  | 145        |
| 4-9-7. Float Square Root [ESQR].....                                  | 146        |
| 4-9-8. Sine [SIN].....  | 147        |
| 4-9-9. Cosine [COS].....  | 148        |
| 4-9-10. TAN [TAN].....  | 149        |
| 4-9-11. ASIN [ASIN].....  | 150        |
| 4-9-12. ACOS [ACOS].....  | 151        |
| 4-9-13. ATAN [ATAN].....  | 152        |
| <b>4-10. RTC INSTRUCTIONS</b> .....                                   | <b>153</b> |
| 4-10-1. Read the clock data [TRD].....                                | 153        |
| 4-10-2. Write Clock Data [TWR].....                                   | 154        |
| <b>5 HIGH SPEED COUNTER (HSC).....</b>                                | <b>156</b> |
| 5-1. FUNCTIONS SUMMARY.....   | 158        |
| 5-2. HSC MODE.....  | 158        |
| 5-3. HSC RANGE.....   | 160        |
| 5-4. HSC INPUT WIRING.....  | 160        |
| 5-5. HSC PORTS ASSIGNMENT.....  | 161        |
| 5-6. READ/WRITE HSC VALUE.....  | 166        |
| 5-6-1. Read HSC value [HSCR].....                                     | 166        |
| 5-6-2. Write HSC value [HSCW].....                                    | 167        |
| 5-7. HSC RESET MODE.....  | 168        |
| 5-8. AB PHASE COUNTER MULTIPLICATION SETTING.....                     | 168        |
| 5-9. HSC EXAMPLE.....   | 169        |
| 5-10. HSC INTERRUPTION.....   | 170        |
| <b>6 PULSE OUTPUT.....</b>  | <b>178</b> |
| 6-1. FUNCTIONS SUMMARY.....   | 180        |
| 6-2. PULSE OUTPUT TYPES AND INSTRUCTIONS.....                         | 181        |

---

|  |            |
|--|------------|
| 6-2-1. Unidirectional riation pulse output without ACC/DEC time change [PLSY]..... | 181        |
| 6-2-2. Variable Pulse Output [PLSF] .....  | 183        |
| 6-2-3. Multi-segment pulse control at relative position [PLSR].....                | 192        |
| 6-2-4. Pulse Segment Switch [PLSNEXT]/ [PLSNT].....                                | 199        |
| 6-2-5. Pulse Stop [STOP] .....   | 202        |
| 6-2-6. Refresh the pulse number at the port [PLSMV].....                           | 203        |
| 6-2-7. Back to the Origin [ZRN].....   | 204        |
| 6-2-8. Relative position single-segment pulse control [DRVI] .....                 | 210        |
| 6-2-9. Absolute position single-segment pulse control [DRVA] .....                 | 213        |
| 6-2-10. Absolute position multi-segment pulse control [PLSA].....                  | 215        |
| 6-2-11. Relative position multi-section pulse control [PTO].....                   | 222        |
| 6-2-13. Pulse Stop [PSTOP] .....   | 234        |
| 6-3. OUTPUT WIRING .....   | 239        |
| 6-4. NOTES .....   | 239        |
| 6-5. SAMPLE PROGRAMS .....   | 244        |
| 6-6. RELATIVE COILS AND REGISTERS OF PULSE OUTPUT.....                             | 245        |
| <b>7 COMMUNICATION FUNCTION.....</b>   | <b>248</b> |
| 7-1. SUMMARY .....   | 250        |
| 7-1-1. COM port.....   | 250        |
| 7-1-2. Communication Parameters.....   | 3          |
| 7-2. MODBUS COMMUNICATION .....  | 7          |
| 7-2-1. Function.....   | 7          |
| 7-2-2. Address .....   | 8          |
| 7-2-3 Modbus communication format.....   | 9          |
| 7-2-4. Communication Instructions .....  | 11         |
| 7-2-5. Application.....  | 20         |
| 7-3. FREE FORMAT COMMUNICATION .....   | 23         |
| 7-3-1. Communication mode .....  | 23         |
| 7-3-2. Suitable condition.....   | 24         |
| 7-3-3. Instruction form.....   | 24         |
| 7-3-4. Free format communication application.....                                  | 28         |
| 7-4. CAN BUS FUNCTIONS .....   | 30         |
| 7-4-1. Brief Introduction of CAN-bus .....   | 30         |
| 7-4-2. External Wiring .....   | 31         |
| 7-4-3. CAN Bus Network Form .....  | 31         |
| 7-4-4. CAN-bus Instructions.....   | 32         |
| 7-4-5. Communication Form of Internal Protocol.....                                | 36         |
| 7-4-6. CAN Free Format Communication.....  | 38         |
| <b>8 PID CONTROL FUNCTION .....</b>  | <b>47</b>  |
| 8-1. BRIEF INTRODUCTIONS OF THE FUNCTIONS.....                                     | 48         |
| 8-2. INSTRUCTION FORMS .....   | 48         |
| 8-3. PARAMETERS SETTING.....   | 50         |
| 8-3-1. Registers and their functions.....  | 51         |

|  |            |
|--|------------|
| 8-3-2. Parameters Description.....                   | 53         |
| 8-4. AUTO TUNE MODE .....                            | 54         |
| 8-5. ADVANCED MODE .....                             | 57         |
| 8-6. APPLICATION OUTLINES .....                      | 57         |
| 8-7. APPLICATION.....                                | 58         |
| <b>9 C FUNCTION BLOCK.....</b>                       | <b>59</b>  |
| 9-1. SUMMARY .....                                   | 60         |
| 9-2. INSTRUCTION FORMAT.....                         | 60         |
| 9-3. OPERATION STEPS .....                           | 61         |
| 9-4. IMPORT AND EXPORT THE FUNCTIONS .....           | 63         |
| 9-5. EDIT THE FUNC BLOCKS .....                      | 64         |
| 9-6. PROGRAM EXAMPLE.....                            | 67         |
| 9-7. APPLICATION POINTS.....                         | 70         |
| 9-8. FUNCTION TABLE .....                            | 72         |
| <b>10 SEQUENCE BLOCK.....</b>                        | <b>74</b>  |
| 10-1. CONCEPT OF THE BLOCK.....                      | 76         |
| 10-1-1. BLOCK summarization.....                     | 76         |
| 10-1-2. The reason to use BLOCK.....                 | 77         |
| 10-2. CALL THE BLOCK .....                           | 78         |
| 10-2-1. Add the BLOCK.....                           | 78         |
| 10-2-2. Move the BLOCK .....                         | 81         |
| 10-2-3. Delete the BLOCK.....                        | 83         |
| 10-2-4. Modify the BLOCK.....                        | 83         |
| 10-3. EDIT THE INSTRUCTION INSIDE THE BLOCK.....     | 85         |
| 10-3-1. Common item .....                            | 85         |
| 10-3-2. Pulse item.....                              | 86         |
| 10-3-3. Modbus item.....                             | 87         |
| 10-3-4. Wait item .....                              | 87         |
| 10-3-5. Frequency inverter item.....                 | 88         |
| 10-3-6. Free format communication item.....          | 91         |
| 10-4. RUNNING FORM OF THE BLOCK .....                | 92         |
| 10-5. BLOCK INSTRUCTION EDITING RULES.....           | 95         |
| 10-6. BLOCK RELATED INSTRUCTIONS .....               | 98         |
| 10-6-1. Instruction explanation.....                 | 98         |
| 10-6-2. The timing sequence of the instructions..... | 100        |
| 10-7. BLOCK FLAG BIT AND REGISTER .....              | 104        |
| 10-8. PROGRAM EXAMPLE .....                          | 105        |
| <b>11 SPECIAL FUNCTION INSTRUCTIONS.....</b>         | <b>108</b> |
| 11-1. PWM PULSE WIDTH MODULATION .....               | 110        |
| 11-2. FREQUENCY TESTING.....                         | 111        |
| 11-3. PRECISE TIME.....                              | 113        |
| 11-4. INTERRUPTION.....                              | 116        |

---

|  |            |
|--|------------|
| 11-4-1. External Interruption .....                                  | 116        |
| 11-4-2. Time Interruption.....                                       | 119        |
| <b>12 APPLICATION PROGRAM SAMPLES .....</b>                          | <b>122</b> |
| 12-1. PULSE OUTPUT APPLICATION .....                                 | 123        |
| 12-2. MODBUS COMMUNICATION SAMPLES .....                             | 125        |
| 12-3. FREE FORMAT COMMUNICATION EXAMPLE.....                         | 128        |
| <b>APPENDIX 1 SPECIAL SOFT DEVICE LIST .....</b>                     | <b>133</b> |
| APPENDIX 1-1. SPECIAL AUXILIARY RELAY LIST .....                     | 134        |
| APPENDIX 1-2. LIST OF SPECIAL MEMORY AND SPECIAL DATA REGISTER ..... | 142        |
| APPENDIX 1-3. ID LIST OF THE EXPANSIONS.....                         | 148        |
| APPENDIX 1-4. SPECIAL FLASH REGISTER LIST.....                       | 153        |
| <b>APPENDIX 2 SPECIAL FUNCTION VERSION REQUIREMENTS.....</b>         | <b>157</b> |
| <b>APPENDIX 3 APPLIED INSTRUCTION.....</b>                           | <b>158</b> |
| <b>APPENDIX 4 PLC RESOURCE CONFLICT LIST .....</b>                   | <b>163</b> |

# **1 Program Summary**

---

XC series PLC as the controllers accept the signal and execute the program in the controller, to fulfill the requirements from the users. In this chapter, we start with the program forms, then introduce the main features, the supported two program languages etc.

1-1. Programmer Controller Features

1-2. Program Language

1-3. Program Format

## 1-1. Program Controller Features

### Program Language

XC series PLC support two kinds of program languages, instruction list and ladder, the two languages can convert to the other;

### Security of the Program

To avoid the stolen or wrong modifying of user program, we encrypt the program. When uploading the encrypted program, it will check in the form of password. This can maintain the user's copyright; meantime, it limits the download, to avoid the modification with the program spitefully.

### Program comments

When the user program is too long, adding comments to the program and its soft components is necessary.

### Offset Function

Add offset appendix (like X3[D100]、M10[D100]、D0[D100]) behind coils, data registers can realize indirect addressing. For example, when D100=9, X3[D100] =X14; M10 [D100] =M19, D0 [D100] =D9

### Rich Basic Functions

- XC series PLC offers enough basic instructions, can fulfill basic sequential control, data moving and comparing, arithmetic operation, logic control, data loop and shift etc.
- XC series PLC also support special compare, high speed pulse, frequency testing, precise time, PID control, position control etc for interruption, high speed counter (HSC).

### C Language Function Block

XC series PLC support C language function block, users can call the edited function block freely. This function reduces the program quantity greatly.

### Stop when power ON Function

XC series PLC support "Stop when power on PLC" function. With this function, when there is a serious problem during PLC running, use this method to stop all output immediately. Besides, with this method, connect PLC when parameters are set wrongly.

## Communication Function

XC series PLC support many communication formats, like basic Modbus communication, CABBUS communication, and free format communication. Besides, via special network module, connect to Ether net, GPRS net.

## 1-2. Program Language

### 1-2-1. Type

XC series PLC support two types of program language:

## Instruction List

Instruction list inputs in the form of “LD”, “AND”, “OUT” etc. This is the basic input form of the programs, but it’s hard to read and understand;

| E.g.: | Step | Instruction | Soft Components |
|-------|------|-------------|-----------------|
|       | 0    | LD          | X000            |
|       | 1    | OR          | Y005            |
|       | 2    | ANI         | X002            |
|       | 3    | OUT         | Y005            |

## Ladder

With sequential control signal and soft components, draw the sequential control graph on program interface, this method is called “Ladder”. This method use coil signs etc. to represent sequential circuit, so it’s easier to understand the program. Meantime, monitor PLC with the circuit’s status.

E.g.:

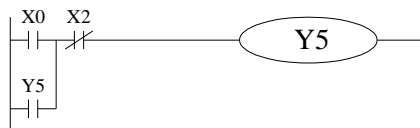

### 1-2-2. Alternation

Convert the above two methods freely:

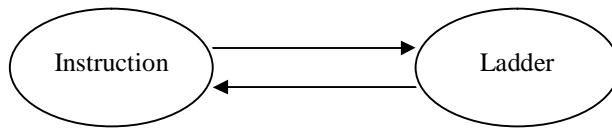

### 1-3. Program Format

#### Direct Input

The above two program methods can input in the correspond interface separately, especially in the ladder window, there is a instruction hint function, which improves the program efficiency greatly;

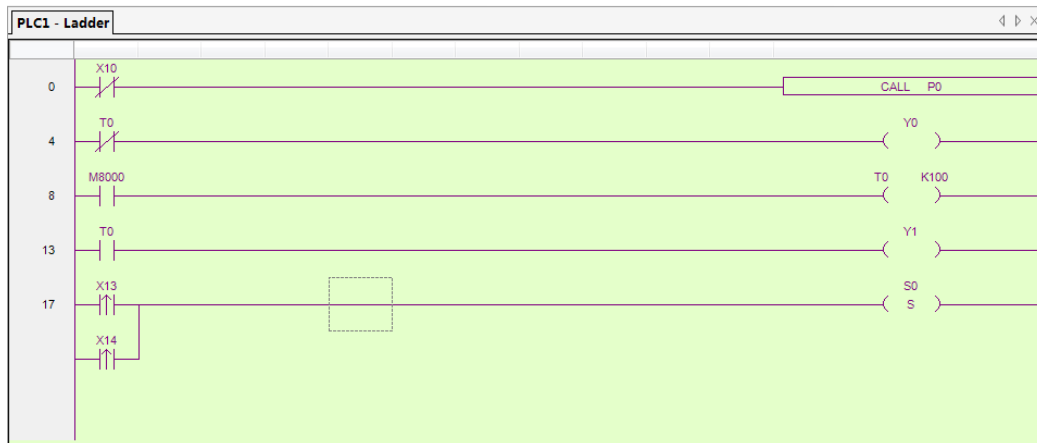

#### Panel Configuration

As in XC series PLC, there are many instructions which have complicate usage and many using methods, like pulse output instruction, main unit PID etc. XCPPro also support the configure interface for these special instructions. In the correspond configure interface, input the parameters and ID according to the requirements will be ok.

**PID Instruction Parameter Config**

Target Value (SV) D0    Measure Value (PV) D10    Parameter: D4000    Output: Y0

**Parameter Config**

Manual     Auto

Sampling Time : 0 ms

Proportion Gain (KP): 0 %

Integration Time (TI): 0 \*100ms

Differential Time (TD): 0 \*10ms

PID Computation Scope: 0

PID Control Death Band: 0

Self Study Periodic Value: 0

**Overshoot Config**

Enable Overshoot     Disable Overshoot

Each time adjust the increase: 100 %

Current target value resident Count: 15

**Mode Config**

Common Mode     Advanced Mode

Input Filter Constant (a): 0 %

Differential Increase (KD): 50 %

Output Upper Limit Value: 4095

Output Lower Limit Value: 0

**Direction Config**

Negative Movement     Positive Movement

Negative Movement: Along with the increase of the measures definite value PV, outputvalue MV will also reduce. It's usually used in heat up control.

Positive Movement: Along with the increase of the measures definite value PV, outputvalue MV will also increase. It's usually used in cool control.

Hold Mem Register: Can't Read  
Parameter Range: D4000 - D4043

Read From PLC    Write To PLC    OK    Cancel

For the details of panel configuration, please refer XC series PLC user manual 【software part】 .

## 2 Soft Component's Function

---

In chapter 1, we briefly tell the program language of XC series PLC. However, the most important element to a program is the operands. These elements relate to the relays and registers inside the controller. In this chapter, we will describe the functions and using methods of these relays and registers.

2-1. Summary of the Soft Components

2-2. Structure of the Soft Components

2-3. List of the Soft Components

2-4. Input/output Relays (X、 Y)

2-5. Auxiliary Relays (M)

2-6. Status Relays (S)

2-7. Timers (T)

2-8. Counters (C)

2-9. Data Registers (D)

2-10. Constant (K、 H)

2-11. Pointer (P、 I)

2-12. Program Principle

## 2-1. Summary of the Soft Components

There are many relays, timers and counters inside PLC. They all have countless NO (Normally ON) and NC (Normally Closed) contactors. Connect these contactors with the coils will make a sequential control circuit. Below, we will introduce these soft components briefly;

### Input Relay (X)

- Usage of the input relays

The input relays are used to accept the external ON/OFF signal, we use **X** to state.

- Address Specify Principle

- In each basic unit, specify the ID of input relay, output relay in the form of X000~X007, X010~X017..., Y000~Y007, Y010~Y017... (octal form)
- The expansion module's ID obeys the principle of channel 1 starts from X100/Y100, channel 2 starts from X200/Y200... 7 expansions can be connected in total.

- Points to pay attention when using

- For the input relay's input filter, we use digital filter. Users can change the filter parameters via relate settings.
- We equip enough output relays inside PLC; for the output relays beyond the input/output points, use them as auxiliary relays, program as normal contactors/coils.

### Output Relay (Y)

- Usage of the output relays

Output relays are the interface of drive external loads, represent with sign Y;

- Address Assignment Principle

- In each basic unit, assign the ID of output relays in the form of Y000~Y007, Y010~Y017... this octal format.
- The ID of expansion obeys the principle of: channel 1 starts from Y100, channel 2 starts from Y200... 7 expansions could be connected totally.

### Auxiliary Relays (M)

- Usage of Auxiliary Relays

Auxiliary relays are equipped inside PLC, represent with the sign of M;

- Address assignment principle

In basic units, assign the auxiliary address in the form of decimal

- Points to note

- This type of relays are different with the input/output relays, they can't get external load, can only use in program;
- Retentive relays can keep its ON/OFF status in case of PLC power OFF;

## Status Relays (S)

- Usage of status relays
  - Used as relays in Ladder, represent with “S”
- Address assignment principle
  - In basic units, assign the ID in the form of decimal
- Points to note
  - If not used as operation number, they can be used as auxiliary relays, program as normal contactors/coils. Besides, they can be used as signal alarms, for external diagnose.

## Timer (T)

- Usage of the timers
  - Timers are used to calculate the time pulse like 1ms, 10ms, 100ms etc. when reach the set value, the output contactors acts, represent with “T”
- Address assignment principle
  - In basic units, assign the timer's ID in the form of decimal. But divide ID into several parts according to the clock pulse, accumulate or not. Please refer to chapter 2-2 for details.
- Time pulse
  - There are three specifications for the timer's clock pulse: 1ms、10ms、100ms. If choose 10ms timer, carry on addition operation with 10ms time pulse;
- Accumulation/not accumulation
  - The times are divided into two modes: accumulation time means even the timer coil's driver is OFF, the timer will still keep the current value; while the not accumulation time means when the count value reaches the set value, the output contact acts, the count value clears to be 0;

## Counter (C)

According to different application and purpose, we can divide the counters to different types as below:

- For internal count (for general using/power off retentive usage)
  - 16 bits counter: for increment count, the count range is 1~32,767
  - 32 bits counter: for increment count, the count range is 1~2,147,483,647
  - These counters can be used by PLC's internal signal. The response speed is one scan cycle or longer.
- For High Speed Count (Power off retentive)
  - 32 bits counter: for increment/decrement count, the count range is -2,147,483,648~+2,147,483,647
  - (Single phase increment count, single phase increment/decrement count, AB phase count) specify to special input points
  - The high speed counter can count 80KHz frequency, it separates with the PLC's scan

cycle;

### **Data Register (D)**

- Usage of Data Registers

Data Registers are used to store data represent with “D”

- Addressing Form

The data registers in XC series PLC are all 16 bits (the highest bit is the sign bit), combine two data registers together can operate 32 bits (the highest bit is the sign bit) data process.

- Points to note

Same with other soft components, data registers also have common usage type and power off retentive type.

### **FlashROM Register (FD)**

- Usage of FlashROM registers

FlashROM registers are used to store data soft components, represent with “FD”

- Addressing Form

In basic units, FlashROM registers are addressed in form of decimal;

- Points to note

Even the battery powered off, this area can keep the data. So this area is used to store important parameters. FlashROM can write in about 1,000,000 times, and it takes time at every write. Frequently write can cause permanent damage of FD.

### **Internal extension registers (ED)**

- Usage of ED registers

Internal extension registers ED are used to store the data.

- Addressing form

In basic units, ED registers are addressed in the form of decimal;

- Points to note

ED registers are power-loss retentive. It fits for data transfer instructions such as MOV, BMOV, and FMOV.

### Constant (B) (K) (H)

- In every type of data in PLC, B represents Binary, K represents Decimal, and H represents Hexadecimal. They are used to set timers and counters value, or operands of application instructions.

## 2-2. Structure of Soft Components

### 2-2-1. Structure of Memory

In XC series PLC, there are many registers. Besides the common data registers D, FlashROM registers, we can also make registers by combining bit soft components.

#### Data Register D

- For common use, 16 bits
- For common use, 32 bits (via combine two sequential 16 bits registers)
- For power off retentive usage, can modify the retentive zone
- For special usage, occupied by the system, can't be used as common instruction's parameters
- For offset usage (indirect specifies)
  - Form:  $D_n[D_m]$ 、 $X_n[D_m]$ 、 $Y_n[D_m]$ 、 $M_n[D_m]$  etc.

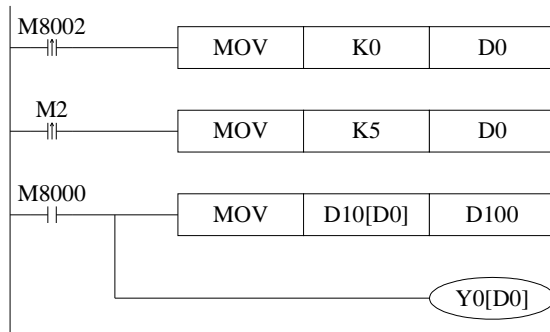

In the above sample, if  $D0=0$ , then  $D100=D10$ ,  $Y0$  is ON.

If  $M2$  turns from OFF to be ON,  $D0=5$ , then  $D100=D15$ ,  $Y5$  is ON.

Therein,  $D10[D0]=D[10+D0]$ ,  $Y0[D0]=Y[0+D0]$ .

- The word offset combined by bit soft components:  $DX_n[D_m]$  represents  $DX[n+D_m]$ .
- The soft components with offset, the offset can be represented by soft component D.

### Timer T/Counter C

- For common usage, 16 bits, represent the current value of timer/counter;
- For common usage, 32 bits, (via combine two sequential 16 bits registers)
- To represent them, just use the letter + ID method, such as T10, C11.

E.g.

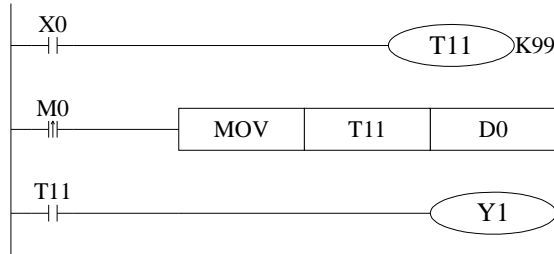

In the above example, MOV T11 D0, T11 represents word register;  
LD T11, T11 represents bit register.

### FlashROM Register FD

- For power off retentive usage, 16 bits
- For power off retentive usage, 16 bits, (via combine two sequential 16 bits registers)
- For special usage, occupied by the system, can't be used as common instruction's parameters

### Expansion internal register ED

- For common usage, 16 bits,
- For common usage, 32 bits, (via combine two sequential 16 bits registers)

### Bit soft components combined to be register

- For common usage, 16 bits, (via combine two sequential 16 bits registers)
- The soft components which can be combined to be words are: X、Y、M、S、T、C
- Format: add “D” in front of soft components, like DM10, represents a 16 bits data from M10~M25
- Get 16 points from DXn, but not beyond the soft components range;
- The word combined by bit soft components can't realize bit addressing;

E.g.:

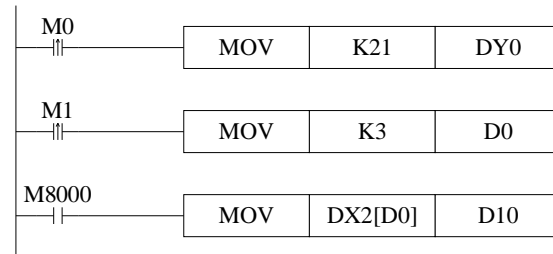

- When M0 changes from OFF to be ON, the value in the word which is combined by Y0~Y17 equals 21, i.e. Y0、Y2、Y4 becomes to be ON
- Before M1 activates, if D0=0, DX2[D0] represents a word combined by X2~X21
- If M1 changes from OFF→ON, D0=3, then DX2[D0] represents a

### 2-2-2. Structure of Bit Soft Components

Bit soft components structure is simple, the common ones are X、Y、M、S、T、C, besides, a bit of a register can also represents:

#### Relay

- Input Relay X, octal type
- Output Relay Y, octal type
- Auxiliary Relay M、S, decimal type
- Auxiliary Relay T、C, decimal type, as the represent method is same with registers, so we need to judge if it's word register or bit register according to the register.

## Register's Bit

- Composed by register's bit, support register D
- Represent method: Dn.m ( $0 \leq m \leq 15$ ): the Nr.m bit of Dn register
- The represent method of word with offset: Dn[Dm].x
- Bit of Word can't compose to be word again;

E.g.:

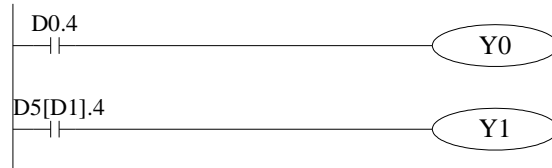

- D0.4 means when the Nr.4 bit of D0 is 1, set Y0 ON .
- D5[D1].4 means bit addressing with offset, if D1=5, then D5[D1] means the Nr.4 bit of D10

## 2-3. Soft Components List

## 2-3-1. Soft Components List

## XC1 Series

| Mnemonic                 | Name           | Range                                       |        |        |        | points |        |        |        |
|--------------------------|----------------|---|--------|--------|--------|--------|--------|--------|--------|
|                          |                | 10 I/O                                      | 16 I/O | 24 I/O | 32 I/O | 10 I/O | 16 I/O | 24 I/O | 32 I/O |
| I/O points <sup>*1</sup> | Input Points   | X0~X4                                       | X0~X7  | X0~X13 | X0~X17 | 5      | 8      | 12     | 16     |
|                          | Output Points  | Y0~Y4                                       | Y0~Y7  | Y0~Y13 | Y0~Y17 | 5      | 8      | 12     | 16     |
| X <sup>*2</sup>          | Internal Relay | X0~X77                                      |        |        |        | 64     |        |        |        |
| Y <sup>*3</sup>          | Internal Relay | Y0~Y77                                      |        |        |        | 64     |        |        |        |
| M                        | Internal Relay | M0~M199 【M200~M319】 <sup>*4</sup>           |        |        |        | 320    |        |        |        |
|                          |                | For Special Usage <sup>*5</sup> M8000~M8079 |        |        |        | 128    |        |        |        |
|                          |                | For Special Usage <sup>*5</sup> M8120~M8139 |        |        |        |        |        |        |        |
|                          |                | For Special Usage <sup>*5</sup> M8170~M8172 |        |        |        |        |        |        |        |
|                          |                | For Special Usage <sup>*5</sup> M8238~M8242 |        |        |        |        |        |        |        |
|                          |                | For Special Usage <sup>*5</sup> M8350~M8370 |        |        |        |        |        |        |        |
| S                        | Flow           | S0~S31                                      |        |        |        | 32     |        |        |        |
| T                        | Timer          | T0~T23: 100ms not accumulation              |        |        |        | 80     |        |        |        |
|                          |                | T100~T115: 100ms accumulation               |        |        |        |        |        |        |        |
|                          |                | T200~T223: 10ms not accumulation            |        |        |        |        |        |        |        |
|                          |                | T300~T307: 10ms accumulation                |        |        |        |        |        |        |        |
|                          |                | T400~T403: 1ms not accumulation             |        |        |        |        |        |        |        |

|    |                                 |   |     |
|----|---------------------------------|---|-----|
|    |                                 | T500~T503: 1ms accumulation                   |     |
| C  | Counter                         | C0~C23: 16 bits forward counter               | 48  |
|    |                                 | C300~C315: 32 bits forward/backward counter   |     |
|    |                                 | C600~C603: single-phase HSC                   |     |
|    |                                 | C620~C621                                     |     |
|    |                                 | C630~C631                                     |     |
| D  | Data Register                   | D0~D99 【D100~D149】 <sup>※4</sup>              | 150 |
|    |                                 | For Special Usage <sup>※5</sup> D8000~D8029   | 138 |
|    |                                 | For Special Usage <sup>※5</sup> D8060~D8079   |     |
|    |                                 | For Special Usage <sup>※5</sup> D8120~D8179   |     |
|    |                                 | For Special Usage <sup>※5</sup> D8240~D8249   |     |
|    |                                 | For Special Usage <sup>※5</sup> D8306~D8313   |     |
|    |                                 | For Special Usage <sup>※5</sup> D8460~D8469   |     |
| FD | FlashROM Register <sup>※6</sup> | FD0~FD411                                     | 412 |
|    |                                 | For Special Usage <sup>※5</sup> FD8000~FD8011 | 98  |
|    |                                 | For Special Usage <sup>※5</sup> FD8202~FD8229 |     |
|    |                                 | For Special Usage <sup>※5</sup> FD8306~FD8315 |     |
|    |                                 | For Special Usage <sup>※5</sup> FD8323~FD8335 |     |
|    |                                 | For Special Usage <sup>※5</sup> FD8350~FD8384 |     |

### XC2 Series

| Mnemonic                 | Name           | Range                                       |        |                  |                  | Points |        |           |           |
|--------------------------|----------------|---|--------|------------------|------------------|--------|--------|-----------|-----------|
|                          |                | 14 I/O                                      | 16 I/O | 24/32 I/O        | 48/60 I/O        | 14 I/O | 16 I/O | 24/32 I/O | 48/60 I/O |
| I/O Points <sup>※1</sup> | Input Points   | X0~X7                                       | X0~X7  | X0~X15<br>X0~X21 | X0~X33<br>X0~X43 | 8      | 8      | 14/18     | 28/36     |
|                          | Output Points  | Y0~Y5                                       | Y0~Y7  | Y0~Y11<br>Y0~Y15 | Y0~Y23<br>Y0~Y27 | 6      | 8      | 10/14     | 20/24     |
| X <sup>※2</sup>          | Internal Relay | X0~X1037                                    |        |                  |                  | 544    |        |           |           |
| Y <sup>※3</sup>          | Internal Relay | Y0~Y1037                                    |        |                  |                  | 544    |        |           |           |
| M                        | Internal Relay | M0~M2999<br>【M3000~M7999】 <sup>※4</sup>     |        |                  |                  | 8000   |        |           |           |
|                          |                | For Special Usage <sup>※5</sup> M8000~M8767 |        |                  |                  | 768    |        |           |           |
| S                        | Flow           | S0~S511<br>【S512~S1023】 <sup>※4</sup>       |        |                  |                  | 1024   |        |           |           |
| T                        | Timer          | T0~T99: 100ms not accumulation              |        |                  |                  | 640    |        |           |           |

|    |                |   |      |
|----|----------------|---|------|
|    |                | T100~T199: 100ms accumulation                 |      |
|    |                | T200~T299: 10ms not accumulation              |      |
|    |                | T300~T399: 10ms accumulation                  |      |
|    |                | T400~T499: 1ms not accumulation               |      |
|    |                | T500~T599: 1ms accumulation                   |      |
|    |                | T600~T639: 1ms precise time                   |      |
| C  | Counter        | C0~C299: 16 bits forward counter              | 640  |
|    |                | C300~C599: 32 bits forward/backward counter   |      |
|    |                | C600~C619: single-phase HSC                   |      |
|    |                | C620~C629: double-phase HSC                   |      |
|    |                | C630~C639: AB phase HSC                       |      |
| D  | Data Register  | D0~D999<br>【D4000~D4999】 <sup>※4</sup>        | 2000 |
|    |                | For Special Usage <sup>※5</sup> D8000~D8511   | 612  |
|    |                | For Special Usage <sup>※5</sup> D8630~D8729   |      |
| FD | FLASH Register | FD0~FD127                                     | 128  |
|    |                | For Special Usage <sup>※5</sup> FD8000~FD8383 | 384  |

**XC3 Series**

| Mnemonic                 | Name           | Range                                       |                  |                  | Points |           |           |
|--------------------------|----------------|---|------------------|------------------|--------|-----------|-----------|
|                          |                | 14 I/O                                      | 24/32 I/O        | 48/60 I/O        | 14 I/O | 24/32 I/O | 48/60 I/O |
| I/O Points <sup>※1</sup> | Input Points   | X0~X7                                       | X0~X15<br>X0~X21 | X0~X33<br>X0~X43 | 8      | 14/18     | 28/36     |
|                          | Output Points  | Y0~Y5                                       | Y0~Y11<br>Y0~Y15 | Y0~Y23<br>Y0~Y27 | 6      | 10/14     | 20/24     |
| X <sup>※2</sup>          | Internal Relay | X0~X1037                                    |                  |                  | 544    |           |           |
| Y <sup>※3</sup>          | Internal Relay | Y0~Y1037                                    |                  |                  | 544    |           |           |
| M                        | Internal Relay | M0~M2999<br>【M3000~M7999】 <sup>※4</sup>     |                  |                  | 8000   |           |           |
|                          |                | For Special Usage <sup>※5</sup> M8000~M8767 |                  |                  | 768    |           |           |
| S                        | Flow           | S0~S511<br>【S512~S1023】 <sup>※4</sup>       |                  |                  | 1024   |           |           |

|                  |                                 |   |       |
|------------------|---------------------------------|---|-------|
| T                | TIMER                           | T0~T99: 100ms not accumulation                | 640   |
|                  |                                 | T100~T199: 100ms accumulation                 |       |
|                  |                                 | T200~T299: 10ms not accumulation              |       |
|                  |                                 | T300~T399: 10ms accumulation                  |       |
|                  |                                 | T400~T499: 1ms not accumulation               |       |
|                  |                                 | T500~T599: 1ms accumulation                   |       |
|                  |                                 | T600~T639: 1ms precise time                   |       |
| C                | COUNTER                         | C0~C299: 16 bits forward counter              | 640   |
|                  |                                 | C300~C599: 32 bits forward/backward counter   |       |
|                  |                                 | C600~C619: single-phase HSC                   |       |
|                  |                                 | C620~C629: double-phase HSC                   |       |
|                  |                                 | C630~C639: AB phase HSC                       |       |
| D                | DATA REGISTER                   | D0~D3999<br>【D4000~D7999】 <sup>※4</sup>       | 8000  |
|                  |                                 | For Special Usage <sup>※5</sup> D8000~D9023   | 1024  |
| FD               | FlashROM REGISTER <sup>※6</sup> | FD0~FD3071                                    | 3072  |
|                  |                                 | For Special Usage <sup>※5</sup> FD8000~FD9023 | 1024  |
| ED <sup>※7</sup> | EXPANSION'S INTERNAL REGISTER   | ED0~ED16383                                   | 16384 |

### XC5 Series

| Mnemonic                 | Name           | I/O RANGE                                   |                  | POINTS    |           |
|--------------------------|----------------|---|------------------|-----------|-----------|
|                          |                | 24/32 I/O                                   | 48/60 I/O        | 24/32 I/O | 48/60 I/O |
| I/O Points <sup>※1</sup> | Input Points   | X0~X15<br>X0~X21                            | X0~X33<br>X0~X43 | 14/18     | 28/36     |
|                          | Output Points  | Y0~Y11<br>Y0~Y15                            | Y0~Y23<br>Y0~Y27 | 10/14     | 20/24     |
| X <sup>※2</sup>          | Internal Relay | X0~X1037                                    |                  | 544       |           |
| Y <sup>※3</sup>          | Internal Relay | Y0~Y1037                                    |                  | 544       |           |
| M                        | Internal Relay | M0~M3999<br>【M4000~M7999】 <sup>※4</sup>     |                  | 8000      |           |
|                          |                | For Special Usage <sup>※5</sup> M8000~M8767 |                  | 768       |           |
| S                        | Flow           | S0~S511<br>【S512~S1023】 <sup>※4</sup>       |                  | 1024      |           |
| T                        | TIMER          | T0~T99: 100ms not accumulation              |                  | 640       |           |

|                  |                                 |   |       |
|------------------|---------------------------------|---|-------|
|                  |                                 | T100~T199: 100ms accumulation                 |       |
|                  |                                 | T200~T299: 10ms not accumulation              |       |
|                  |                                 | T300~T399: 10ms accumulation                  |       |
|                  |                                 | T400~T499: 1ms not accumulation               |       |
|                  |                                 | T500~T599: 1ms accumulation                   |       |
|                  |                                 | T600~T639: 1ms precise time                   |       |
| C                | COUNTER                         | C0~C299: 16 bits forward counter              | 640   |
|                  |                                 | C300~C599: 32 bits forward/backward counter   |       |
|                  |                                 | C600~C619: single-phase HSC                   |       |
|                  |                                 | C620~C629: double-phase HSC                   |       |
|                  |                                 | C630~C639: AB phase HSC                       |       |
| D                | DATA REGISTER                   | D0~D3999<br>【D4000~D7999】 <sup>※4</sup>       | 8000  |
|                  |                                 | For Special Usage <sup>※5</sup> D8000~D9023   | 1024  |
| FD               | FlashROM REGISTER <sup>※6</sup> | FD0~FD7167                                    | 7168  |
|                  |                                 | For Special Usage <sup>※5</sup> FD8000~FD9023 | 1024  |
| ED <sup>※7</sup> | EXPANSION'S INTERNAL REGISTER   | ED0~ED36863                                   | 36864 |

**XCM Series**

| Mnemonic                 | Name           | I/O range                                   |        | Points    |        |
|--------------------------|----------------|---|--------|-----------|--------|
|                          |                | 24/32 I/O                                   | 48 I/O | 24/32 I/O | 48 I/O |
| I/O Points <sup>※1</sup> | Input Points   | X0~X15<br>X0~X21                            | X0~X33 | 14/18     | 28     |
|                          | Output Points  | Y0~Y11<br>Y0~Y15                            | Y0~Y23 | 10/14     | 20     |
| X <sup>※2</sup>          | Internal Relay | X0~X1037                                    |        | 544       |        |
| Y <sup>※3</sup>          | Internal Relay | Y0~Y1037                                    |        | 544       |        |
| M                        | Internal Relay | M0~M2999<br>【M3000~M7999】 <sup>※4</sup>     | 8000   |           |        |
|                          |                | For Special Usage <sup>※5</sup> M8000~M8767 | 768    |           |        |
| S                        | Flow           | S0~S511<br>【S512~S1023】 <sup>※4</sup>       | 1024   |           |        |
| T                        | TIMER          | T0~T99: 100ms not accumulation              | 640    |           |        |
|                          |                | T100~T199: 100ms accumulation               |        |           |        |
|                          |                | T200~T299: 10ms not accumulation            |        |           |        |

|                  |                                 |   |       |
|------------------|---------------------------------|---|-------|
|                  |                                 | T300~T399: 10ms accumulation                  |       |
|                  |                                 | T400~T499: 1ms not accumulation               |       |
|                  |                                 | T500~T599: 1ms accumulation                   |       |
|                  |                                 | T600~T639: 1ms precise time                   |       |
| C                | COUNTER                         | C0~C299: 16 bits forward counter              | 640   |
|                  |                                 | C300~C599: 32 bits forward/backward counter   |       |
|                  |                                 | C600~C619: single-phase HSC                   |       |
|                  |                                 | C620~C629: double-phase HSC                   |       |
|                  |                                 | C630~C639: AB phase HSC                       |       |
| D                | DATA REGISTER                   | D0~D2999<br>【D4000~D4999】 <sup>※4</sup>       | 4000  |
|                  |                                 | For Special Usage <sup>※5</sup> D8000~D9023   | 1024  |
| FD               | FlashROM REGISTER <sup>※6</sup> | FD0~FD1535                                    | 1536  |
|                  |                                 | For Special Usage <sup>※5</sup> FD8000~FD8349 | 460   |
|                  |                                 | For Special Usage <sup>※5</sup> FD8890~FD8999 |       |
| ED <sup>※7</sup> | EXPANSION'S INTERNAL REGISTER   | ED0~ED36863                                   | 36864 |

**XCC Series**

| Mnemonic                 | Name           | I/O range                                   | Points    |
|--------------------------|----------------|---|-----------|
|                          |                | 24/32 I/O                                   | 24/32 I/O |
| I/O Points <sup>※1</sup> | Input Points   | X0~X15<br>X0~X21                            | 14/18     |
|                          | Output Points  | Y0~Y11<br>Y0~Y15                            | 10/14     |
| X <sup>※2</sup>          | Internal Relay | X0~X1037                                    | 544       |
| Y <sup>※3</sup>          | Internal Relay | Y0~Y1037                                    | 544       |
| M                        | Internal Relay | M0~M2999<br>【M3000~M7999】 <sup>※4</sup>     | 8000      |
|                          |                | For Special Usage <sup>※5</sup> M8000~M8767 | 768       |
| S                        | Flow           | S0~S511<br>【S512~S1023】 <sup>※4</sup>       | 1024      |
| T                        | TIMER          | T0~T99: 100ms not accumulation              | 640       |
|                          |                | T100~T199: 100ms accumulation               |           |
|                          |                | T200~T299: 10ms not accumulation            |           |
|                          |                | T300~T399: 10ms accumulation                |           |
|                          |                | T400~T499: 1ms not accumulation             |           |

|                  |                                 |   |       |
|------------------|---------------------------------|---|-------|
|                  |                                 | T500~T599: 1ms accumulation                   |       |
|                  |                                 | T600~T639: 1ms precise time                   |       |
| C                | COUNTER                         | C0~C299: 16 bits forward counter              | 640   |
|                  |                                 | C300~C599: 32 bits forward/backward counter   |       |
|                  |                                 | C600~C619: single-phase HSC                   |       |
|                  |                                 | C620~C629: double-phase HSC                   |       |
|                  |                                 | C630~C639: AB phase HSC                       |       |
| D                | DATA REGISTER                   | D0~D3999<br>【D4000~D7999】 <sup>※4</sup>       | 8000  |
|                  |                                 | For Special Usage <sup>※5</sup> D8000~D9023   | 1024  |
| FD               | FlashROM REGISTER <sup>※6</sup> | FD0~FD1023                                    | 1024  |
|                  |                                 | For Special Usage <sup>※5</sup> FD8000~FD9023 | 1024  |
| ED <sup>※7</sup> | EXPANSION'S INTERNAL REGISTER   | ED0~ED36863                                   | 36864 |

※1: I/O points, means the terminal number that users can use to wire the input, output

※2: X, means the internal input relay, the X beyond Input points can be used as middle relay;

※3: Y, means the internal output relay, the Y beyond Output points can be used as middle relay;

※4: The memory zone in 【   】 is power off retentive zone, soft components D、M、S、T、C can change the retentive area via setting. Please refer to 2-3-2 for details;

※5: For special use, means the special registers occupied by the system, can't be used for other purpose. Please refer to Appendix 1.

※6: FlashROM registers needn't set the power off retentive zone, when power is off (no battery), the data will not lose

※7: Expansion's internal register ED, require PLC hardware V3.0 or above

※8: Input coils、 output relays are in octal form, the other registers are in decimal form;

※9: The I/O that is not wired with external device can be used as fast internal relays;

※10: For the soft components of expansion devices, please refer to relate manuals;

### 2-3-2. Power off Retentive Zone

The power off retentive area of XC series PLC are set as below, this area can be set by user again;

|                   | Soft components | SET AREA | FUNCTION                                 | System's default value | Retentive Zone |
|-------------------|-----------------|----------|--|------------------------|----------------|
| <b>XC1 Series</b> | D               | FD8202   | Start tag of D power off retentive zone  | 100                    | D100~D149      |
|                   | M               | FD8203   | Start tag of M power off retentive zone  | 200                    | M200~M319      |
|                   | T               | FD8204   | Start tag of T power off retentive zone  | 640                    | Not set        |
|                   | C               | FD8205   | Start tag of C power off retentive zone  | 320                    | C320~C631      |
|                   | S               | FD8206   | Start tag of S power off retentive zone  | 512                    | S0~S31         |
| <b>XC2 Series</b> | D               | FD8202   | Start tag of D power off retentive zone  | 4000                   | D4000~D4999    |
|                   | M               | FD8203   | Start tag of M power off retentive zone  | 3000                   | M3000~M7999    |
|                   | T               | FD8204   | Start tag of T power off retentive zone  | 640                    | Not set        |
|                   | C               | FD8205   | Start tag of C power off retentive zone  | 320                    | C320~C639      |
|                   | S               | FD8206   | Start tag of S power off retentive zone  | 512                    | S512~S1023     |
| <b>XC3 Series</b> | D               | FD8202   | Start tag of D power off retentive zone  | 4000                   | D4000~D7999    |
|                   | M               | FD8203   | Start tag of M power off retentive zone  | 3000                   | M3000~M7999    |
|                   | T               | FD8204   | Start tag of T power off retentive zone  | 640                    | Not set        |
|                   | C               | FD8205   | Start tag of C power off retentive zone  | 320                    | C320~C639      |
|                   | S               | FD8206   | Start tag of S power off retentive zone  | 512                    | S512~S1023     |
|                   | ED              | FD8207   | Start tag of ED power off retentive zone | 0                      | ED0~ED16383    |
| <b>XC5 Series</b> | D               | FD8202   | Start tag of D power off retentive zone  | 4000                   | D4000~D7999    |
|                   | M               | FD8203   | Start tag of M power off retentive zone  | 4000                   | M4000~M7999    |
|                   | T               | FD8204   | Start tag of T power off retentive zone  | 640                    | Not set        |
|                   | C               | FD8205   | Start tag of C power off retentive zone  | 320                    | C320~C639      |
|                   | S               | FD8206   | Start tag of S power off retentive zone  | 512                    | S512~S1023     |
|                   | ED              | FD8207   | Start tag of ED power off retentive zone | 0                      | ED0~ED36863    |
| <b>XCM Series</b> | D               | FD8202   | Start tag of D power off retentive zone  | 4000                   | D4000~D4999    |
|                   | M               | FD8203   | Start tag of M power off retentive       | 3000                   | M3000~M7999    |

|            |    |        |  |      |             |
|------------|----|--------|--|------|-------------|
| XCC series |    |        | zone                                     |      |             |
|            | T  | FD8204 | Start tag of T power off retentive zone  | 640  | Not set     |
|            | C  | FD8205 | Start tag of C power off retentive zone  | 320  | C320~C639   |
|            | S  | FD8206 | Start tag of S power off retentive zone  | 512  | S512~S1023  |
|            | ED | FD8207 | Start tag of ED power off retentive zone | 0    | ED0~ED36863 |
|            | D  | FD8202 | Start tag of D power off retentive zone  | 4000 | D4000~D7999 |
| XCC series | M  | FD8203 | Start tag of M power off retentive zone  | 3000 | M3000~M7999 |
|            | T  | FD8204 | Start tag of T power off retentive zone  | 620  | Not set     |
|            | C  | FD8205 | Start tag of C power off retentive zone  | 320  | C320~C639   |
|            | S  | FD8206 | Start tag of S power off retentive zone  | 512  | S512~S1023  |
|            | ED | FD8207 | Start tag of ED power off retentive zone | 0    | ED0~ED36863 |

User can set the power off retentive area through the XCPpro software:  
 Open XCPpro software, click save hold memory. Click read from PLC to show the current area.  
 For example: For XC3 series PLC, D: 100 means the area is from D100~D7999.  
 After changing the area, please click ok and download an empty program inside PLC.

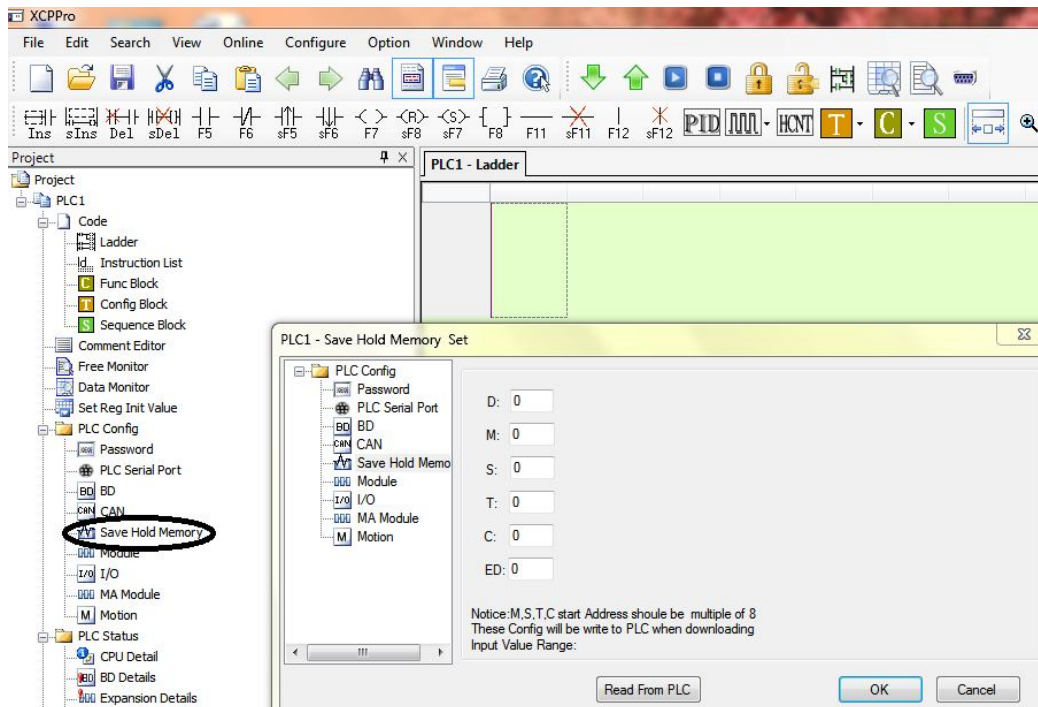

## 2-4. Input/output relays (X, Y)

### Number List

XC series PLC's input/output are all in octal form, each series numbers are listed below:

| Series | Name | Range  |        |        |        | Points |        |        |        |
|--------|------|--------|--------|--------|--------|--------|--------|--------|--------|
|        |      | 10 I/O | 16 I/O | 24 I/O | 32 I/O | 10 I/O | 16 I/O | 24 I/O | 32 I/O |
| XC1    | X    | X0~X4  | X0~X7  | X0~X13 | X0~X17 | 5      | 8      | 12     | 16     |
|        | Y    | Y0~Y4  | Y0~Y7  | Y0~Y13 | Y0~Y17 | 5      | 8      | 12     | 16     |

| Series | Name | Range  |        |                  |                  | Points |        |           |           |
|--------|------|--------|--------|------------------|------------------|--------|--------|-----------|-----------|
|        |      | 14 I/O | 16 I/O | 24/32 I/O        | 48/60 I/O        | 14 I/O | 16 I/O | 24/32 I/O | 48/60 I/O |
| XC2    | X    | X0~X7  | X0~X7  | X0~X15<br>X0~X21 | X0~X33<br>X0~X43 | 8      | 8      | 14/18     | 28/36     |
|        | Y    | Y0~Y5  | Y0~Y7  | Y0~Y11<br>Y0~Y15 | Y0~Y23<br>Y0~Y27 | 6      | 8      | 10/14     | 20/24     |

| Series | Name | Range  |                            |                  | Points |           |           |
|--------|------|--------|----------------------------|------------------|--------|-----------|-----------|
|        |      | 14 I/O | 24/32/42 I/O               | 48/60 I/O        | 14 I/O | 24/32 I/O | 48/60 I/O |
| XC3    | X    | X0~X7  | X0~X15<br>X0~X21<br>X0~X27 | X0~X33<br>X0~X43 | 8      | 14/18     | 28/36     |
|        | Y    | Y0~Y5  | Y0~Y11<br>Y0~Y15<br>Y0~Y21 | Y0~Y23<br>Y0~Y27 | 6      | 10/14     | 20/24     |

| Series | Name | Range            |                  | Points    |           |
|--------|------|------------------|------------------|-----------|-----------|
|        |      | 24/32 I/O        | 48/60 I/O        | 24/32 I/O | 48/60 I/O |
| XC5    | X    | X0~X15<br>X0~X21 | X0~X33<br>X0~X43 | 14/18     | 28/36     |
|        | Y    | Y0~Y11<br>Y0~Y15 | Y0~Y23<br>Y0~Y27 | 10/14     | 20/24     |

| Series | Name | Range  |        |        | Points |        |        |
|--------|------|--------|--------|--------|--------|--------|--------|
|        |      | 24 I/O | 32 I/O | 48 I/O | 24 I/O | 32 I/O | 48 I/O |
| XCM    | X    | X0~X15 | X0~X21 | X0~X33 | 14     | 18     | 28     |
|        | Y    | Y0~Y11 | Y0~Y15 | Y0~Y23 | 10     | 14     | 20     |

| Series | Name | Range  |        | Points |        |
|--------|------|--------|--------|--------|--------|
|        |      | 24 I/O | 32 I/O | 24 I/O | 32 I/O |
| XCC    | X    | X0~X15 | X0~X21 | 14     | 18     |
|        | Y    | Y0~Y11 | Y0~Y15 | 10     | 14     |

### Function

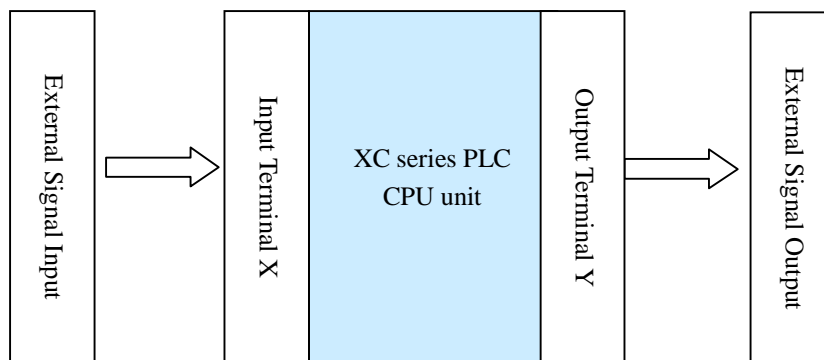

#### Input Relay X

- PLC's input terminals are used to accept the external signal input, while the input relays are a type of optical relays to connect PLC inside and input terminals;
- The input relays have countless normally ON/OFF contactors, they can be used freely;
- The input relays which are not connected with external devices can be used as fast internal relays;

#### Output Relay Y

- PLC's output terminals can be used to send signals to external loads. Inside PLC, output relay's external output contactors (including relay contactors, transistor's contactors) connect with output terminals.
- The output relays have countless normally ON/OFF contactors, they can be used freely;
- The output relays which are not connected with external devices can be used as fast internal relays;

### Execution Order

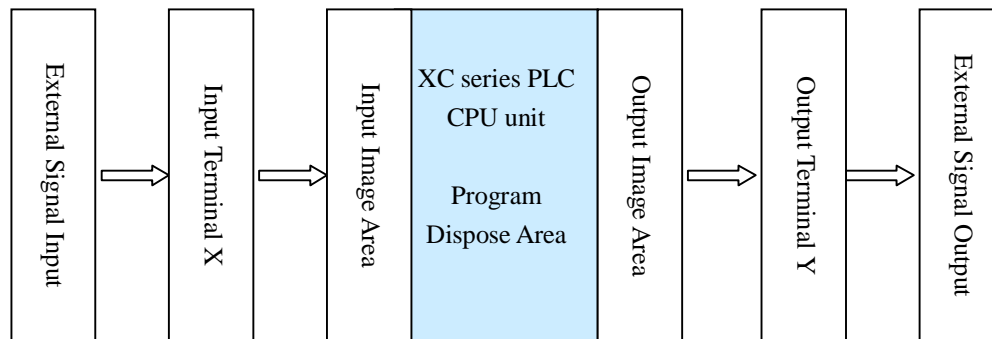

- **Input Disposal**
  - Before PLC executing the program, read every input terminal's ON/OFF status of PLC to the image area.
  - In the process of executing the program, even the input changed, the content in the input image area will not change. However, in the input disposal of next scan cycle, read out the change.
- **Output Disposal**
  - Once finish executing all the instructions, transfer the ON/OFF status of output Y image area to the output lock memory area. This will be the actual output of the PLC.
  - The contacts used for the PLC's external output will act according to the device's response delay time.

## 2-5. Auxiliary Relay (M)

### Number List

The auxiliary relays M in XC series PLC are all in decimal form; please refer the details from tables below:

| SERIES | NAME | RANGE          |                             |                 |
|--------|------|----------------|-----------------------------|-----------------|
|        |      | FOR COMMON USE | FOR POWER-OFF RETENTIVE USE | FOR SPECIAL USE |
| XC1    | M    | M000~M199      | M200~M319                   | M8000~M8079     |
|        |      |                |                             | M8120~M8139     |
|        |      |                |                             | M8170~M8172     |
|        |      |                |                             | M8238~M8242     |
|        |      |                |                             | M8350~M8370     |

| SERIES | NAME | RANGE          |                             |                 |
|--------|------|----------------|-----------------------------|-----------------|
|        |      | FOR COMMON USE | FOR POWER-OFF RETENTIVE USE | FOR SPECIAL USE |
| XC2    | M    | M000~M2999     | M3000~M7999                 | M8000~M8767     |

| SERIES | NAME | RANGE          |                             |                 |
|--------|------|----------------|-----------------------------|-----------------|
|        |      | FOR COMMON USE | FOR POWER-OFF RETENTIVE USE | FOR SPECIAL USE |
| XC3    | M    | M000~M2999     | M3000~M7999                 | M8000~M8767     |

| SERIES | NAME | RANGE          |                             |                 |
|--------|------|----------------|-----------------------------|-----------------|
|        |      | FOR COMMON USE | FOR POWER-OFF RETENTIVE USE | FOR SPECIAL USE |
| XC5    | M    | M000~M3999     | M4000~M7999                 | M8000~M8767     |

| SERIES | NAME | RANGE          |                             |                 |
|--------|------|----------------|-----------------------------|-----------------|
|        |      | FOR COMMON USE | FOR POWER-OFF RETENTIVE USE | FOR SPECIAL USE |
| XCM    | M    | M000~M2999     | M3000~M7999                 | M8000~M8767     |

| SERIES | NAME | RANGE          |                             |                 |
|--------|------|----------------|-----------------------------|-----------------|
|        |      | FOR COMMON USE | FOR POWER-OFF RETENTIVE USE | FOR SPECIAL USE |
| XCC    | M    | M000~M2999     | M3000~M7999                 | M8000~M8767     |

### Function

In PLC, auxiliary relays M are used frequently. This type of relay's coil is same with the output relay. They are driven by soft components in PLC;

Auxiliary relays M have countless normally ON/OFF contactors. They can be used freely, but this type of contactors can't drive the external loads.

- For common use
  - This type of auxiliary relays can be used only as normal auxiliary relays. I.e. if power supply suddenly stops during the running, the relays will disconnect.
  - Common usage relays can't be used for power off retentive, but the zone can be modified;
- For Power Off Retentive Use
  - The auxiliary relays for power off retentive usage, even the PLC is OFF, they can keep the ON/OFF status before power OFF.

- Power off retentive zone can be modified by the user;
- Power off retentive relays are usually used to memory the status before stop the power, then when power the PLC on again, the status can run again;
- For Special Usage
  - Special relays refer some relays which are defined with special meanings or functions, start from M8000.
  - There are two types of usages for special relays, one type is used to drive the coil, the other type is used to the specified execution;  
E.g.: M8002 is the initial pulse, activates only at the moment of start  
M8033 is "all output disabled"
  - Special auxiliary relays can't be used as normal relay M;

## 2-6. Status Relay (S)

### Address List

XC series PLC's status relays S are addressed in form of decimal; each subfamily's ID is listed below:

| SERIES | NAME | RANGE          |                             |
|--------|------|----------------|-----------------------------|
|        |      | FOR COMMON USE | FOR POWER-OFF RETENTIVE USE |
| XC1    | S    | S000~S031      | -                           |

| SERIES | NAME | RANGE          |                             |
|--------|------|----------------|-----------------------------|
|        |      | FOR COMMON USE | FOR POWER-OFF RETENTIVE USE |
| XC2    | S    | S000~S511      | S512~S1023                  |

| SERIES | NAME | RANGE          |                             |
|--------|------|----------------|-----------------------------|
|        |      | FOR COMMON USE | FOR POWER-OFF RETENTIVE USE |
| XC3    | S    | S000~S511      | S512~S1023                  |

| SERIES | NAME | RANGE          |                             |
|--------|------|----------------|-----------------------------|
|        |      | FOR COMMON USE | FOR POWER-OFF RETENTIVE USE |
| XC5    | S    | S000~S511      | S512~S1023                  |

| SERIES | NAME | RANGE          |                             |
|--------|------|----------------|-----------------------------|
|        |      | FOR COMMON USE | FOR POWER-OFF RETENTIVE USE |
| XCM    | S    | S000~S511      | S512~S1023                  |

| SERIES | NAME | RANGE |  |
|--------|------|-------|--|
|--------|------|-------|--|

|     |   | FOR COMMON USE | FOR POWER-OFF RETENTIVE USE |
|-----|---|----------------|-----------------------------|
| XCC | S | S000~S511      | S512~S1023                  |

**Function**

Status relays are very important in ladder program; usually use them with instruction “STL”. In the form on flow, this can make the program's structure much clear and easy to modify;

- For common use  
After shut off the PLC power, this type of relays will be OFF status;
- For Power Off Retentive Use
  - The status relays for power off retentive usage, even the PLC is OFF, they can keep the ON/OFF status before power OFF.
  - Power off retentive zone can be modified by the user;
- The status relays also have countless “normally ON/OFF” contactors. So users can use them freely in the program;

**2-7. Timer (T)****Address List**

XC series PLC's timers T are addressed in form of decimal; each subfamily's ID is listed below:

| SERIES                          | NAME | RANGE   |        |
|---------------------------------|------|---|--------|
|                                 |      | FOR COMMON USE  | POINTS |
| XC1                             | T    | T0~T23: 100ms not accumulation  | 80     |
|                                 |      | T100~T115: 100ms accumulation   |        |
|                                 |      | T200~T223: 10ms not accumulation  |        |
|                                 |      | T300~T307: 10ms accumulation  |        |
|                                 |      | T400~T403: 1ms not accumulation   |        |
|                                 |      | T500~T503: 1ms accumulation   |        |
| XC2<br>XC3<br>XC5<br>XCM<br>XCC | T    | T0~T99: 100ms not accumulation<br>T100~T199: 100ms accumulation<br>T200~T299: 10ms not accumulation<br>T300~T399: 10ms accumulation<br>T400~T499: 1ms not accumulation<br>T500~T599: 1ms accumulation<br>T600~T639: 1ms with precise time | 640    |

**Function**

The timers accumulate the 1ms, 10ms, 100ms clock pulse, the output contactor activates when the accumulation reaches the set value;

We use OUT or TMR instruction to time for the **normal** timers. We use constant (K) to set the value, or use data register (D) to indirect point the set value;

Normal Type

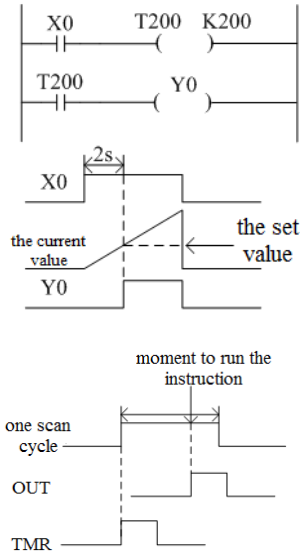

- If X0 is ON, then T200 accumulate 10ms clock pulse based on the current value; when the accumulation value reaches the set value K200, the timer's output contact activates. I.e. the output contact activates 2s later. If X0 breaks, the timer resets, the output contact resets;

- Both OUT and TMR can realize the time function. But if use OUT, the start time is 0; if use TMR, the start time is 1 scan cycle

Accumulation Type

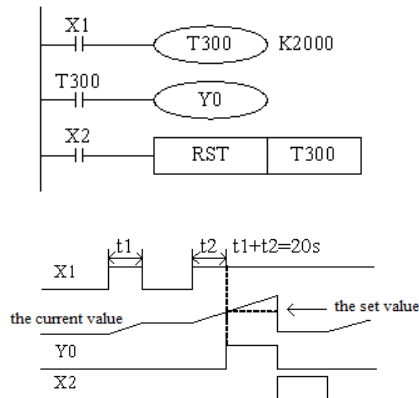

If X001 is ON, then T300 accumulate 10ms clock pulse based on the current value; when the accumulation value reaches the set value K2000, the timer's output contact activates. I.e. the output contact activates 2s later. Even if X0 breaks, the timer will continue to accumulation on re-starting. The accumulation time is 20ms; If X002 is ON, the timer will be reset, the output contacts reset;

Specify the set value

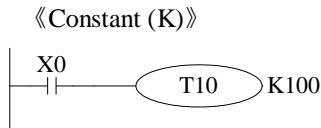

T10 is the timer with 100ms as the unit. Specify 100 as the constant, then  $0.1s \times 100 = 10s$  timer works;

《Register (D)》

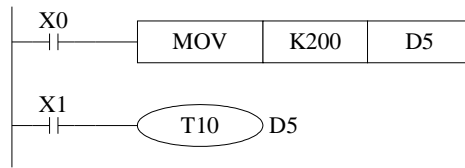

Write the value of indirect data register in the program or input by value switch.

If set as the retentive register, make sure the battery voltage is enough, or the value will be unstable.

**Timer Value**

Timer T0~T599 is 16 bits linear increment mode (0~K32767), when the timer's value reaches the max value K32767, it stops timing. The timer's status keeps still;

**Action Example**

《output delay OFF timer》

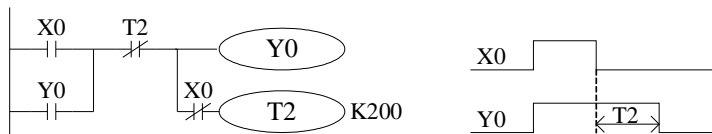

When X000 is ON, output Y000;  
When X000 from ON to OFF, delay T2(20s), then output Y000 is OFF

《twinkle》

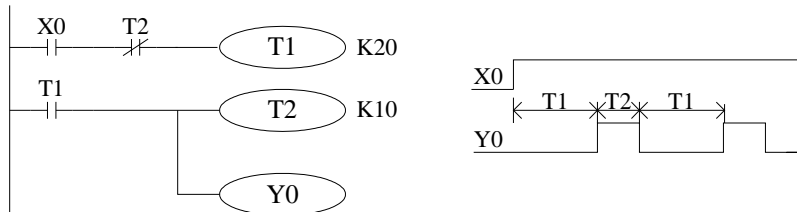

When X000 is ON, Y000 starts to glitter.  
T1 controls the OFF time of Y000, T2 controls the ON time of Y000.

**2-8. Counter (C)**

**Number list**

XC series PLC counters' number are all decimal, please see the following table for all the counter numbers.

| SERIES | NAME | RANGE |
|--------|------|-------|
|--------|------|-------|

|     |   | FOR COMMON USE                              | POINTS |
|-----|---|---|--------|
| XC1 | C | C0~C23: 16 bits forward counter             | 48     |
|     |   | C300~C315: 32 bits forward/backward counter |        |
|     |   | C600~C603: single-phase HSC                 |        |
|     |   | C620~C621                                   |        |
|     |   | C630~C631                                   |        |
| XC2 | C | C0~C299: 16 bits forward counter            | 640    |
| XC3 |   | C300~C599: 32 bits forward/backward counter |        |
| XC5 |   | C600~C619: single-phase HSC                 |        |
| XCM |   | C620~C629: double-phase HSC                 |        |
| XCC |   | C630~C639: AB phase HSC                     |        |

All the counters number meaning:

| TYPE                             | DESCRIPTION   |
|----------------------------------|---|
| 16 bits forward counter          | C0~C299   |
| 32 bits forward/backward counter | C300~C599 (C300,C302...C598)(each occupies 2 counters number) the number should be even |
| HSC (High Speed Counter)         | C600~C634(C600,C602...C634)( each occupies 2 counters number) the number should be even |

※1: Please see chapter 5 for high speed counter.

### Counter characteristics

The characteristics of 16 bits and 32 bits counters:

| Items                         | 16 bits counter   | 32 bits counter   |
|-------------------------------|---|---|
| Count direction               | Positive  | Positive/negative   |
| The set value                 | 1~32,767  | -2,147,483,648~+2,147,483,647                                 |
| The assigned set value        | Constant K or data register   | Same as the left, but data register must be in a couple       |
| Changing of the current value | Change after positive count   | Change after positive count (Loop counter)                    |
| Output contact                | Hold the action after positive count  | Hold the action after positive count, reset if negative count |
| Reset activates               | When executing RST command, counter's current value is 0, output contacts recover |   |
| The current value register    | 16 bits   | 32 bits   |

### Function

The assignment of common use counters and power off retentive counters, can me changed via FD parameters from peripheral devices;

16 bits counter normal/retentive type

16 bits binary increment counters, the valid value is K1~K32,767 (decimal type constant). The set value K0 and K1 has the same meaning. I.e. the output contact works on the first count starts

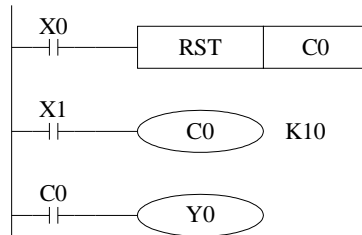

If cut the PLC power supply, the normal counter value become zero, the retentive counter can store the value, it can accumulate the value of last time.

- When X001 is ON once, the counter increases 1. When the counter value is 10, its output is activated. After, when the X001 is ON again, the counter continues increasing 1.
- If X000 is ON, reset counter, the counter value becomes zero.
- It also can set the counter value in D register. For example, D10=123 is the same as K123.

32 bits counter normal/retentive type

32 bits increase/decrease count range is +2147483648 ~ - 2147483647. Set the increase or decrease count mode in M8238.

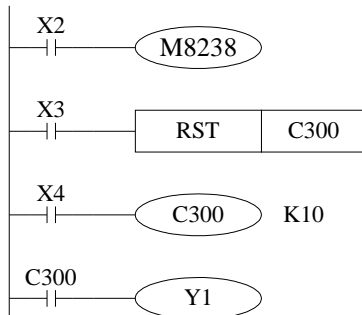

- If M8238=1, it is decrease mode; M8238=0, it is increase mode.
- Set the count value in K or D, if set in D0 register, D0 and D1 will be seemed as one 32bits value.
- X004 is ON, C300 starts to count.

- If X003 is ON, reset the counter and C300 output.
- If use retentive counter, the count value will be stored in PLC.
- 32 bits counter can be used as 32 bits register.

**Set the count value**

It includes 16 bits and 32 bits count value.

◆ 16 bits counter

《set as constant K》

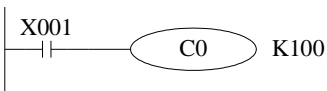

《set in D register》

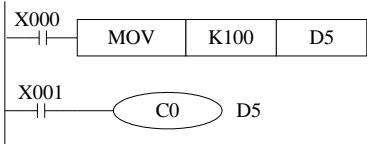

◆ 32 bits counter

《set as constant K》



《set in D register》

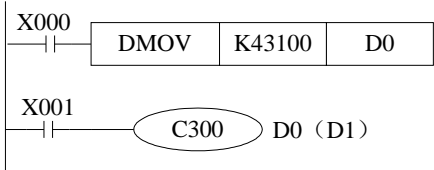

**Count value**

C0~C299 are 16 bits linear increase counter (0~32767), when the counter value reaches 32767, it will stop count and keep the state.

C300~C599 are 32 bits linear increase/decrease counter (-2147483648~+2147483647), when the counter value reaches 2147483647, it will become -2147483648, when the counter value reaches -2147483648, it will become 2147483647, the counter state will change as the count value.

**2-9. Data register (D)**

**Address list**

XC series PLC data register D address is shown as below:

| SERIES     | NAME | RANGE          |                             |                 |      |
|------------|------|----------------|-----------------------------|-----------------|------|
|            |      | FOR COMMON USE | FOR POWER OFF RETENTIVE USE | FOR SPECIAL USE |      |
| XC1        | D    | D0~D99         | D100~D149                   | D8000~D8029     | 138  |
|            |      |                |                             | D8060~D8079     |      |
|            |      |                |                             | D8120~D8179     |      |
|            |      |                |                             | D8240~D8249     |      |
|            |      |                |                             | D8306~D8313     |      |
|            |      |                |                             | D8460~D8469     |      |
| XC2        | D    | D0~D999        | D4000~D4999                 | D8000~D8511     | 612  |
|            |      |                |                             | D8630~D8729     |      |
| XC3<br>XC5 | D    | D0~D3999       | D4000~D7999                 | D8000~D9023     | 1024 |
| XCM        | D    | D0~D2999       | D3000~D4999                 | D8000~D9023     | 1024 |

**Structure**

Data register is soft element which used to store data, it includes 16 bits and 32 bits. ( 32 bits contains two registers, the highest bit is sign bit )

**16 bits**

16 bits register range is -32,768 ~ +32,767

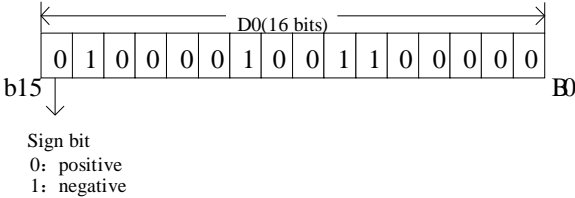

Use the applied instruction to read and write the register data. Or use other devices such as HMI.

32 bits

32 bits value is consisted of two registers. The range is -2147483648 ~ 2147483647.

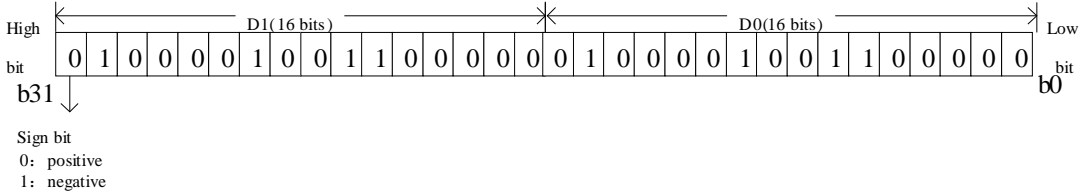

When appoint the 32bits register, if set D0, the PLC will connect the next register D1 as the high bits. Generally, we often appoint even address register.

**Function**

- Normal type
  - When write a new value in the register, the former value will be covered.
  - When PLC from RUN to STOP or STOP to RUN, the value in the register will be cleared.
- Retentive type
  - When PLC from RUN to STOP or power off, the value in the register will be retained.
  - The retentive register range can be set by user.
- Special type
  - Special register is used to set special data, or occupied by the system.
  - Some special registers are initialized when PLC is power on.
  - Please refer to the appendix for the special register address and function.
- Used as offset (indirect appoint)
  - Data register can be used as offset of soft element.
  - Format : Dn[Dm]、 Xn[Dm]、 Yn[Dm]、 Mn[Dm].
  - Word offset: DXn[Dm] means DX[n+Dm].
  - The offset value only can be set as D register.

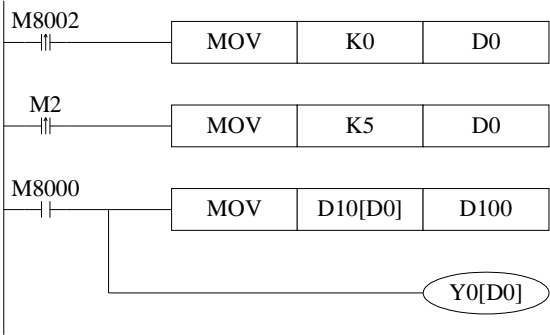

When  $D0=0$ ,  $D100=D10$ ,  $Y0$  is ON;  
 When  $M2$  is from OFF→ON,  $D0=5$ ,  $D100=D15$ ,  $Y5$  is ON.  
 $D10[D0]=D[10+D0]$ ,  $Y0[D0]=Y[0+D0]$ .

### Example

Data register D can deal with many kinds of data and realize various controls.

#### ● Data storage

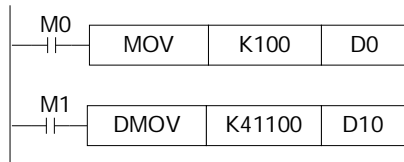

When  $M0$  is ON, write 100 into  $D0$ . (16 bits value)

When  $M1$  is ON, write 41100 into  $D11, D10$  (32bits value)

#### ● Data transfer

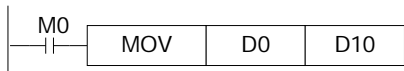

When  $M0$  is ON, transfer the value of  $D10$  to  $D0$

#### ● Read the timer and counter

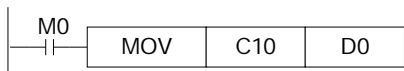

When  $M0$  is ON, move the value of  $C10$  to  $D0$ .

#### ● As the set value of timer and counter

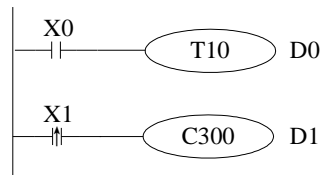

When  $X0$  is ON,  $T10$  starts to work, the time is set in  $D0$ .

When  $X1$  is ON once,  $C300$  increase 1, when  $C300$  value= $D1$ ,  $C300$  coil outputs.

## 2-10. Constant

### Data process

XC series PLC use the following 5 number systems.

- DEC: DECIMAL NUMBER
  - The preset number of counter and timer ( constant K)
  - The number of Auxiliary relay M, timer T, counter C, state S.

- Set as the operand value and action of applied instruction (constant K)
- HEX: HEXADECIMAL NUMBER
  - Set as the operand value and action of applied instruction (constant K)
- BIN: BINARY NUMBER
  - Inside the PLC, all the numbers will be processed by binary. But when monitoring on the device, all the binary will be transformed into HEX or DEC.
- OCT: OCTAL NUMBER
  - XC series PLC I/O relays are addressed in OCT. Such as [0-7, 10-17,....70-77,100-107].
- BCD: BINARY CODE DECIMAL
  - BCD uses 4 bits binary number to display decimal number 0-9. BCD can be used in 7 segments LED and BCD output digital switch
- Other numbers ( float number)
  - XC series PLC can calculate high precision float numbers. It is calculated by binary numbers, and display by decimal numbers.

### Display

PLC program should use K, H to process values. K means decimal numbers, H means hex numbers. Please note the PLC input/output relay use octal address.

- Constant K
 

K is used to display decimal numbers. K10 means decimal number 10. It is used to set timer and counter value, operand value of applied instruction.
- Constant H
 

H is used to display hex numbers. H10 means hex number 10. It is used to set operand value of applied instruction.

## 2-11. PROGRAM PRINCIPLE

- Tag P、 I
 

Tag P、 I are used in branch division and interruption.  
 Tag for branch (P) is used in condition jump or subroutine's jump target;  
 Tag for interruption (I) is used to specify the e input interruption, time interruption;  
 The tags P、 I are both in decimal form, each coding principle is listed below:

| SERIES              | NAME | RANGE    |
|---------------------|------|----------|
| XC1、XC2、XC3、XC5、XCM | P    | P0~P9999 |

| SERIES | NAME | RANGE                     |                          |                           |   |
|--------|------|---------------------------|--------------------------|---------------------------|---|
|        |      | FOR EXTERNAL INTERRUPTION |                          |                           | For time interruption   |
|        |      | Input terminals           | Rising edge interruption | Falling edge interruption |   |
| XC2    | I    | X2                        | I0000                    | I0001                     | There are 10 channels time interruption, the represented method is: I40**~I49**.<br>(“**” represents interruption time, the unit is mm) |
|        |      | X5                        | I0100                    | I0101                     |   |
|        |      | X10                       | I0200                    | I0201                     |   |

| SERIES | NAME | I/O | RANGE                     |                          |                           |   |
|--------|------|-----|---------------------------|--------------------------|---------------------------|---|
|        |      |     | FOR EXTERNAL INTERRUPTION |                          |                           | For time interruption   |
|        |      |     | Input terminals           | Rising edge interruption | Falling edge interruption |   |
| XC3    | I    | 14  | X7                        | I0000                    | I0001                     | There are 10 channels time interruption, the represented method is: I40**~I49**.<br>(“**” represents interruption time, the unit is mm) |
|        |      | 24  | X2                        | I0000                    | I0001                     |   |
|        |      | 32  | X5                        | I0100                    | I0101                     |   |
|        |      |     | X10                       | I0200                    | I0201                     |   |
|        |      | 19  | X10                       | I0000                    | I0001                     |   |
|        |      | 48  | X7                        | I0100                    | I0101                     |   |
|        |      | 60  | X6                        | I0200                    | I0201                     |   |

| SERIES | NAME | I/O      | RANGE                     |                          |                           |   |
|--------|------|----------|---------------------------|--------------------------|---------------------------|---|
|        |      |          | FOR EXTERNAL INTERRUPTION |                          |                           | For time interruption   |
|        |      |          | Input terminals           | Rising edge interruption | Falling edge interruption |   |
| XC5    | I    | 24<br>32 | X2                        | I0000                    | I0001                     | There are 10 channels time interruption, the represented method is: I40**~I49**.<br>(“**” represents interruption time, the unit is mm) |
|        |      |          | X5                        | I0100                    | I0101                     |   |
|        |      |          | X10                       | I0200                    | I0201                     |   |
|        |      |          | X11                       | I0300                    | I0301                     |   |
|        |      | 48<br>60 | X12                       | I0400                    | I0401                     |   |
|        |      |          | X2                        | I0000                    | I0001                     |   |
|        |      |          | X5                        | I0100                    | I0101                     |   |
|        | X10  | I0200    | I0201                     |                          |                           |   |

| SERIES | NAME | I/O      | RANGE                     |                          |                           |  |
|--------|------|----------|---------------------------|--------------------------|---------------------------|--|
|        |      |          | FOR EXTERNAL INTERRUPTION |                          |                           | For time interruption  |
|        |      |          | Input terminals           | Rising edge interruption | Falling edge interruption |  |
| XCM    | I    | 24<br>32 | X2                        | I0000                    | I0001                     | There are 10 channels time interruption, the represented method is: I40**~I49**. (“**” represents interruption time, the unit is mm) |
|        |      |          | X5                        | I0100                    | I0101                     |  |
|        |      |          | X10                       | I0200                    | I0201                     |  |
|        |      |          | X11                       | I0300                    | I0301                     |  |
|        |      |          | X12                       | I0400                    | I0401                     |  |

Tag P

Tag P is usually used in flow, it is used with CJ (condition jump)、CALL (subroutine call)etc.

● Condition Jump CJ

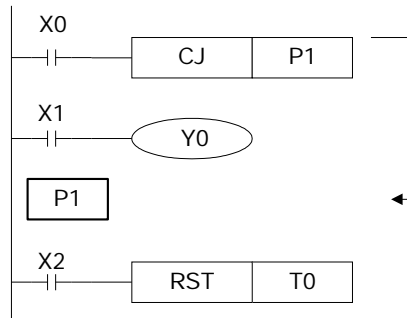

If coil X0 gets ON, jump to the step behind tag P1;  
If the coil X0 is not ON, do not execute jump action, but run with the original program;

● Call the subroutine (CALL)

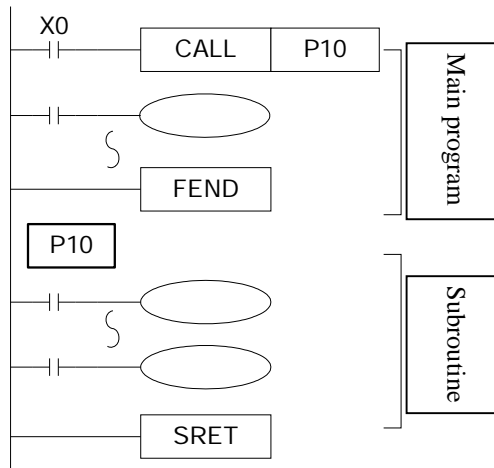

If X0 gets ON, jump to the subroutine from the main program;  
If the coil is not ON, run with the original program;

After executing the subroutine, return to the main program;

Tag I is usually used in interruption, including external interruption, time interruption etc. use with IRET (interruption return)、EI (enable interruption)、DI (disable interruption);

- External interruption
  - Accept the input signal from the special input terminals, not affected by the scan cycle. Activate the input signal, execute the interruption subroutine.
  - With external interruption, PLC can dispose the signal shorter than scan cycle; so it can be used as essential priority disposal in sequence control, or used in short time pulse control.
- Time interruption
  - Execute the interruption subroutine at each specified interruption loop time. Use this interruption in the control which requires it to be different with PLC's operation cycle;

- Action order of input/output relays and response delay
  - Input disposal
 

Before PLC executing the program, read the entire input terminal's ON/OFF status of PLC to the image area. In the process of executing the program, even the input changed, the content in the input image area will not change. However, in the input disposal of next scan cycle, read out the change.
  - Output disposal
 

Once finish executing all the instructions, transfer the ON/OFF status of output Y image area to the output lock memory area. This will be the actual output of the PLC. The contacts used for the PLC's exterior output will act according to the device's response delay time.

When use this input/output format in a batch, the drive time and operation cycle of input filter and output device will also appear response delay.

- **Not accept narrow input pulse signal**

PLC's input ON/OFF time should be longer than its loop time. If consider input filter's response delay 10ms, loop time is 10ms, then ON/OFF time needs 20 ms separately. So, up to  $1,000/(20+20)=25\text{Hz}$  input pulse can't be disposed. But, this condition could be improved when use PLC's special function and applied instructions.

- **Dual output (Dual coils) action**

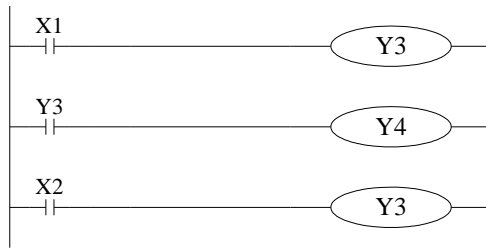

As shown in the left map, please consider the things of using the same coil Y003 at many positions:

E.g. X001=ON, X002=OFF

At first, X001 is ON, its image area is ON, output Y004 is also ON.

When executing dual output (use dual coil), the back side act in prior.

But, as input X002 is OFF, the image area of Y003 is OFF.

So, the actual output is: Y003=OFF, Y004= ON.

---

## 3 Basic Program Instructions

---

In this chapter, we tell the basic instructions and their functions.

3-1. Basic Instructions List

3-2. [LD], [LDI], [OUT]

3-3. [AND], [ANI]

3-4. [OR], [ORI]

3-5. [LDP], [LDF], [ANDP], [ANDF], [ORP], [ORF]

3-6. [LDD], [LDDI]

3-7. [ORB]

3-8. [ANB]

3-9. [MCS], [MCR]

3-10. [ALT]

3-11. [PLS], [PLF]

3-12. [SET], [RST]

---

3-13. [OUT], [RST] (Aim at counter device)

3-14. [NOP], [END]







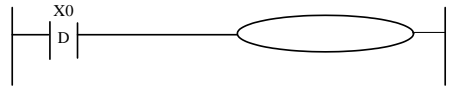
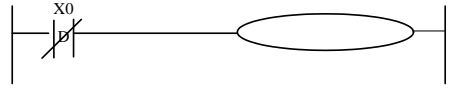
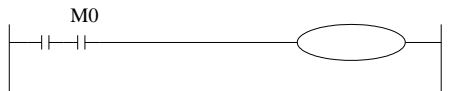
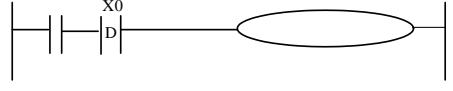
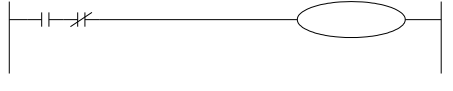
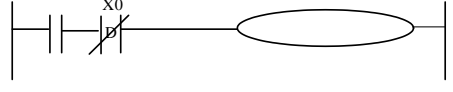

3-15. [GROUP], [GROUPE]



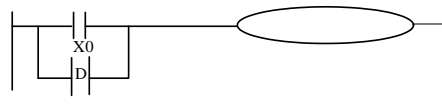

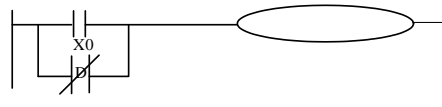

3-16. Items to be attended when programming

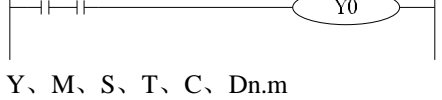
### 3-1. Basic Instructions List

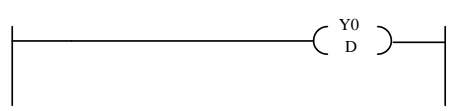
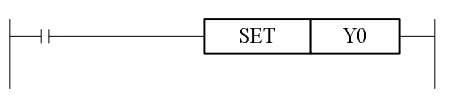
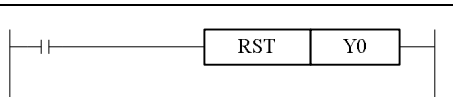
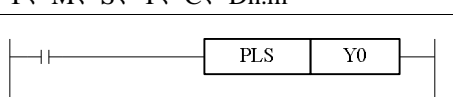
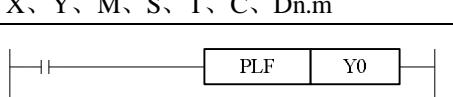
All XC1, XC2, XC3, XC5, XCM, XCC series support the below instructions:

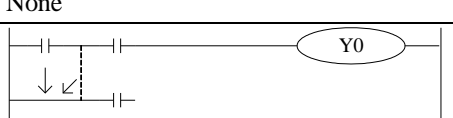

| Mnemonic                    | Function  | Format and Device   | Chapter |
|-----------------------------|---|---|---------|
| LD<br>(LoaD)                | Initial logical operation contact type NO (normally open)   | X, Y, M, S, T, C, Dn.m, FDn.m   | 3-2     |
| LDD<br>(LoaD Directly)      | Read the status from the contact directly                   | <br>X                               | 3-6     |
| LDI<br>(LoaD Inverse)       | Initial logical operation contact type NC (normally closed) | X, Y, M, S, T, C, Dn.m, FDn.m   | 3-2     |
| LDDI                        | Read the normally closed contact directly                   | <br>X                               | 3-6     |
| LDP<br>(LoaD Pulse)         | Initial logical operation-Rising edge pulse                 | X, Y, M, S, T, C, Dn.m, FDn.m   | 3-5     |
| LDF<br>(LoaD Falling Pulse) | Initial logical operation-Falling /trailing edge pulse      | X, Y, M, S, T, C, Dn.m, FDn.m   | 3-5     |
| AND<br>(AND)                | Serial connection of NO (normally open) contacts            | <br>X, Y, M, S, T, C, Dn.m, FDn.m | 3-3     |
| ANDD                        | Read the status from the contact directly                   | <br>X                             | 3-6     |
| ANI<br>(AND Inverse)        | Serial connection of NC (normally closed) contacts          | <br>X, Y, M, S, T, C, Dn.m, FDn.m | 3-3     |
| ANDDI                       | Read the normally closed contact directly                   | <br>X                             | 3-6     |

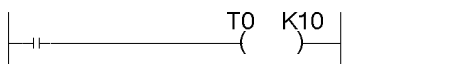
|                                   |  |   |     |
|-----------------------------------|--|---|-----|
| ANDP<br>(AND<br>Pulse)            | Serial connection of rising edge pulse               | <br>X, Y, M, S, T, C, Dn.m, FDn.m   | 3-5 |
| ANDF<br>(AND<br>Falling<br>pulse) | Serial connection of falling/trailing edge pulse     | <br>X, Y, M, S, T, C, Dn.m, FDn.m   | 3-5 |
| OR<br>(OR)                        | Parallel connection of NO (normally open) contacts   | <br>X, Y, M, S, T, C, Dn.m, FDn.m   | 3-4 |
| ORD                               | Read the status from the contact directly            | <br>X                               | 3-6 |
| ORI<br>(OR<br>Inverse)            | Parallel connection of NC (normally closed) contacts | <br>X, Y, M, S, T, C, Dn.m, FDn.m   | 3-4 |
| ORDI                              | Read the normally closed contact directly            | <br>X                              | 3-6 |
| ORP<br>(OR<br>Pulse)              | Parallel connection of rising edge pulse             | <br>X, Y, M, S, T, C, Dn.m, FDn.m | 3-5 |
| ORF<br>(OR<br>Falling<br>pulse)   | Parallel connection of falling/trailing edge pulse   | <br>X, Y, M, S, T, C, Dn.m, FDn.m | 3-5 |
| ANB<br>(ANd<br>Block)             | Serial connection of multiply parallel circuits      | <br>None                          | 3-8 |
| ORB<br>(OR<br>Block)              | Parallel connection of multiply parallel circuits    | <br>None                          | 3-7 |
| OUT<br>(OUT)                      | Final logic operation type coil drive                | <br>Y, M, S, T, C, Dn.m           | 3-2 |

|                          |   |  |      |
|--------------------------|---|--|------|
| OUTD                     | Output to the contact directly  | <br>Y                  | 3-6  |
| SET (SET)                | Set a bit device permanently ON   | <br>Y、M、S、T、C、Dn.m     | 3-12 |
| RST (ReSeT)              | Reset a bit device permanently OFF  | <br>Y、M、S、T、C、Dn.m     | 3-12 |
| PLS (PuLSe)              | Rising edge pulse   | <br>X、Y、M、S、T、C、Dn.m   | 3-11 |
| PLF (PuLse Falling)      | Falling/trailing edge pulse   | <br>X、Y、M、S、T、C、Dn.m   | 3-11 |
| MCS (New bus line start) | Connect the public serial contacts  | <br>None              | 3-9  |
| MCR (Bus line return)    | Clear the public serial contacts  | <br>None             | 3-9  |
| ALT (Alternate state)    | The status of the assigned device is inverted on every operation of the instruction | <br>X、Y、M、S、T、C、Dn.m | 3-10 |
| END (END)                | Force the current program scan to end   | <br>None             | 3-14 |
| GROUP                    | Group   | <br>None             | 3-15 |
| GROUPE                   | Group End   | <br>None             | 3-15 |
| TMR                      | Time  | <br>None             | 2-7  |

### 3-2. [LD], [LDI], [OUT]

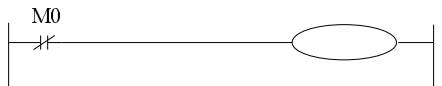
#### Mnemonic and Function

| Mnemonic              | Function  | Format and Operands  |
|-----------------------|---|--|
| LD<br>(LoaD)          | Initial logic operation contact type NO (Normally Open)   | <br>Operands: X、Y、M、S、T、C、Dn.m、FDn.m |
| LDI<br>(LoaD Inverse) | Initial logic operation contact type NC (Normally Closed) | <br>Devices: X、Y、M、S、T、C、Dn.m、FDn.m  |
| OUT<br>(OUT)          | Final logic operation type drive coil                     | <br>Operands: X、Y、M、S、T、C、Dn.m       |

#### Statement

- Connect the LD and LDI instructions directly to the left bus bar. Or use them to define a new block of program when using ANB instruction.
- OUT instruction is the coil drive instruction for the output relays、 auxiliary relays、 status、 timers、 counters. But this instruction can't be used for the input relays
- Can not sequentially use parallel OUT command for many times.
- For the timer's time coil or counter's count coil, after using OUT instruction, set constant K is necessary.
- For the constant K's setting range、 actual timer constant、 program's step relative to OUT instruction (include the setting value), See table below:

| Timer, Counter  | Setting Range of constant K | The actual setting value |
|-----------------|-----------------------------|--------------------------|
| 1ms Timer       | 1~32,767                    | 0.001~32.767 sec         |
| 10ms Timer      |                             | 0.01~327.67 sec          |
| 100ms Timer     |                             | 0.1~3276.7 sec           |
| 16 bits counter | 1~32,767                    | Same as the left         |
| 32 bits counter | 1~2,147,483,647             | Same as the left         |

**Program**

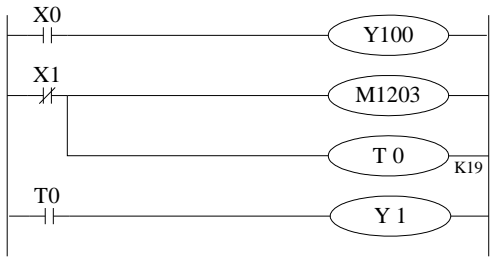



```
LD X0
OUT Y100
LDI X1
OUT M1203
OUT T0 K19
LD T0
OUT Y1
```

**3-3. [AND], [ANI]**

**Mnemonic and Function**

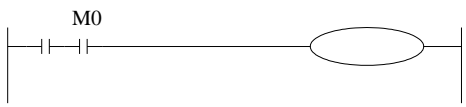
**Statements**

| Mnemonic             | Function   | Format and Operands   |
|----------------------|--|---|
| AND<br>(AND)         | Serial connection of NO (Normally Open) contacts   | <br>Operands: X, Y, M, S, T, C, Dn.m, FDn.m   |
| ANI<br>(ANd Inverse) | Serial connection of NC (Normally Closed) contacts | <br>Operands: X, Y, M, S, T, C, Dn.m, FDn.m |

- Use the AND and the ANI instruction for serial connection of contacts. As many contacts as required can be connected in series. They can be used for many times.
- The output processing to a coil, through writing the initial OUT instruction is called a “follow-on” output (For an example see the program below: OUT M2 and OUT Y003). Follow-on outputs are permitted repeatedly as long as the output order is correct. There’s no limit for the serial connected contacts’ Nr. and follow-on outputs’ number.

**Program**

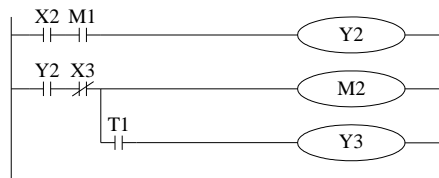

```
LD X2
AND M1
OUT Y2
LD Y2
ANI X3
OUT M2
AND T1
OUT Y3
```

### 3-4. [OR], [ORI]

#### Mnemonic and Function

| Mnemonic            | Function   | Format and Operands                     |
|---------------------|--|---|
| OR<br>(OR)          | Parallel connection of NO (Normally Open) contacts   | Operands: X, Y, M, S, T, C, Dn.m, FDn.m |
| ORI<br>(OR Inverse) | Parallel connection of NC (Normally Closed) contacts | Operands: X, Y, M, S, T, C, Dn.m, FDn.m |

#### Statements

- Use the OR and ORI instructions for parallel connection of contacts. To connect a block that contains more than one contact connected in series to another circuit block in parallel, use an ORB instruction, which will be described later;
- OR and ORI start from the instruction's step, parallel connect with the LD and LDI instruction's step said before. There is no limit for the parallel connect times.

#### Program

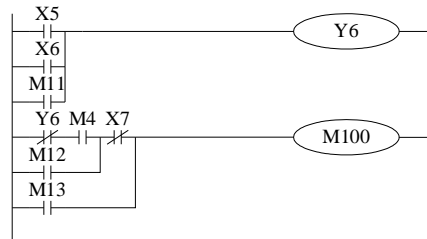

```

LD    X5
OR    X6
OR    M11
OUT   Y6
LDI   Y6
AND   M4
OR    M12
ANI   X7
OR    M13
OUT   M100
    
```

#### Relationship with ANB

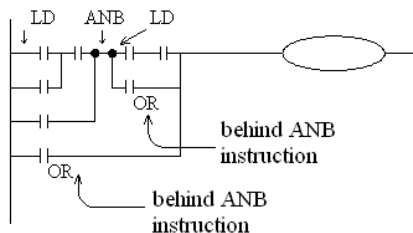

The parallel connection with OR, ORI instructions should connect with LD, LDI instructions in principle. But behind the ANB instruction, it's still ok to add a LD or LDI instruction.

### 3-5. [LDP] , [LDF] , [ANDP] , [ANDF] , [ORP] , [ORF]

#### Mnemonic and Function

#### Statements

- LDP, ANDP, ORP are active for one program scan after the associated devices switch from OFF to ON.
- LDF, ANDF, ORF are active for one program scan after the associated devices switch from ON to OFF.

#### Program

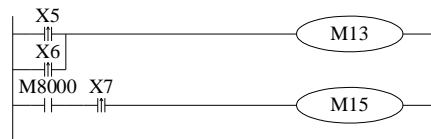

```



LDP   X5
ORP   X6
OUT   M13
LD    M8000
ANDP  X7
OUT   M15
    
```

| Mnemonic                    | Function  | Format and Operands                         |
|-----------------------------|---|---|
| LDP<br>(Load Pulse)         | Initial logical operation-Rising edge pulse           | <br>Operands: X, Y, M, S, T, C, Dn.m, FDn.m |
| LDF<br>(Load Falling pulse) | Initial logical operation Falling/trailing edge pulse | <br>Operands: X, Y, M, S, T, C, Dn.m, FDn.m |
| ANDP<br>(AND Pulse)         | Serial connection of Rising edge pulse                | <br>Operands: X, Y, M, S, T, C, Dn.m, FDn.m |
| ANDF<br>(AND Falling pulse) | Serial connection of Falling/trailing edge pulse      | <br>Operands: X, Y, M, S, T, C, Dn.m, FDn.m |
| ORP<br>(OR Pulse)           | Parallel connection of Rising edge pulse              | <br>Operands: X, Y, M, S, T, C, Dn.m, FDn.m |

|                           |  |                                  |
|---------------------------|--|----------------------------------|
| ORF<br>(OR Falling pulse) | Parallel connection of Falling/trailing edge pulse | Operands: X、Y、M、S、T、C、Dn.m、FDn.m |
|---------------------------|--|----------------------------------|

**3-6. [LDD], [LDDI], [ANDD], [ANDDI], [ORD], [ORDI], [OUTD]**

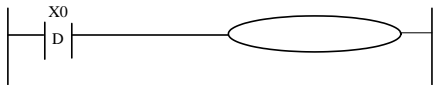
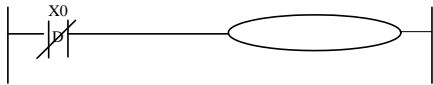
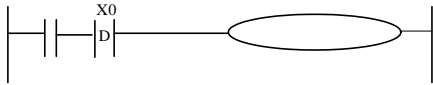
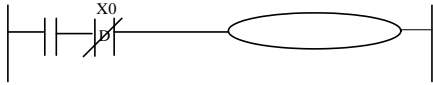
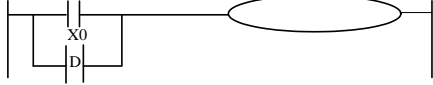
**Mnemonic and Function**

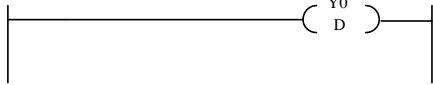
| Mnemonic | Function                                  | Format and Operands  |
|----------|---|--|
| LDD      | Read the status from the contact directly |  <p>Devices: X</p>   |
| LDDI     | Read the normally closed contact directly |  <p>Devices: X</p>   |
| ANDD     | Read the status from the contact directly |  <p>Devices: X</p> |
| ANDDI    | Read the normally closed contact directly |  <p>Devices: X</p> |
| ORD      | Read the status from the contact directly |  <p>Devices: X</p> |
| ORDI     | Read the normally closed contact directly |  <p>Devices: X</p> |
| OUTD     | Output to the contact directly            |  <p>Devices: Y</p> |

**Statement**

- The function of LDD、ANDD、ORD instructions are similar with LD、AND、OR; LDDI、ANDDI、ORDI instructions are similar with LDI、ANDI、ORI; but if the operand is X, the LDD、ANDD、ORD commands read the signal from the terminals directly, this is the only difference.
- OUTD and OUT are output instructions. But if use OUTD, output immediately if the condition comes true, needn't wait the next scan cycle.

**Program**

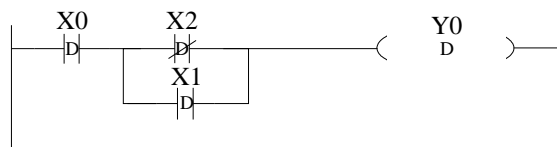

```
LDD  X0
LDDI X2
ORD  X2
ANB
OUTD Y0
```

**3-7. [ORB]**

**Mnemonic and Function**

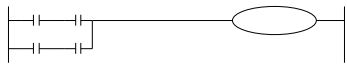
| Mnemonic          | Function  | Format and Devices  |
|-------------------|---|---|
| ORB<br>(OR Block) | Parallel connection of multiply parallel circuits | <br>Devices: none |

**Statements**

- The serial connection with two or more contacts is called "serial block". If parallel connect the serial block, use LD, LDI at the branch start place, use ORB at the stop place;
- As the ANB instruction, an ORB instruction is an independent instruction and is not associated with any device number.
- There are no limitations to the number of parallel circuits when using an ORB instruction in the sequential processing configuration.

**Program**

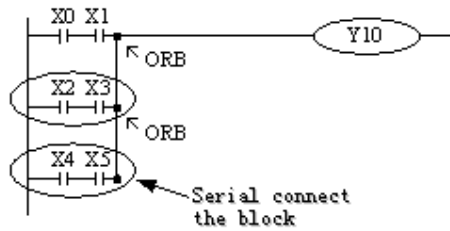

Recommended good programming method:

```
LD X0
AND X1
LD X2
AND X3
ORB
LD X4
AND X5
ORB
```

Non-preferred programming method:

```
LD X0
AND X1
LD X2
AND X3
LD X4
AND X5
ORB
ORB
```

**3-8. [ANB]**



**Mnemonic and Function**

| Mnemonic           | Function  | Format and Devices |
|--------------------|---|--------------------|
| ANB<br>(And Block) | Serial connection of multiply parallel circuits | Devices: none      |

**Statements**

- To declare the starting point of the circuit block, use a LD or LDI instruction. After completing the parallel circuit block, connect it to the preceding block in series using the ANB instruction.
- It is possible to use as many ANB instructions as necessary to connect a number of parallel circuit blocks to the preceding block in series.

**Program**

| Mnemonic                      | Function                                    | Format and Devices  |
|-------------------------------|---|---|
| MCS<br>(Master control)       | Denotes the start of a master control block | <br>Devices: None |
| MCR<br>(Master control Reset) | Denotes the end of a master control block   | <br>Devices: None |

- LD X0
- OR X1
- LD X2 ——— Start of a branch
- AND X3 ———
- LDI X4 ———
- AND X5 ——— End of a parallel circuit block
- ORB ———
- OR X6
- ANB ——— Serial connect with the preceding circuit
- OR X7
- OUT Y20

**3-9. [MCS] , [MCR]**

**Mnemonic and Function**

**Statements**

- After the execution of an MCS instruction, the bus line (LD, LDI) shifts to a point after the MCS instruction. An MCR instruction returns this to the original bus line.
- MCS、MCR instructions should use in pair.
- The bus line could be used nesting. Between the matched MCS、MCR instructions use matched MCS、MCR instructions. The nest level increase with the using of MCS instruction. The max nest level is 10. When executing MCR instruction, go back to the upper bus line.
- When use flow program, bus line management could only be used in the same flow. When end some flow, it must go back to the main bus line.

**Program**

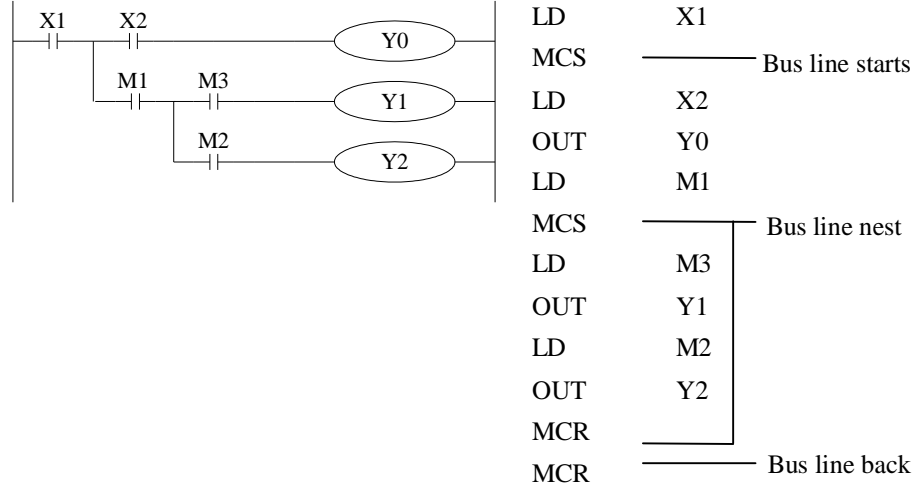

**3-10. [ALT]**

**Mnemonic and Function**

| Mnemonic                  | Function  | Format and Devices               |
|---------------------------|---|----------------------------------|
| ALT<br>(Alternate status) | The status of the assigned devices inverted on every operation of the instruction | <br>Devices: Y, M, S, T, C, Dn.m |

**Statements**

The status of the destination device is alternated on every operation of the ALT instruction.

**Program**

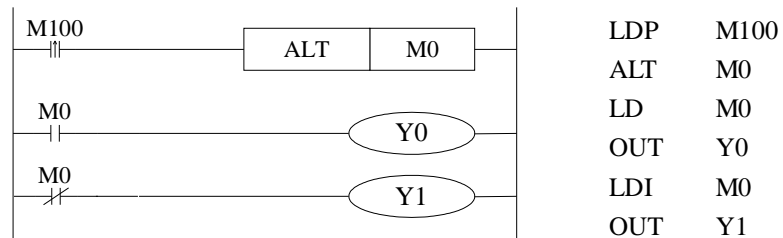

**3-11. [PLS], [PLF]**

**Mnemonic and Function**

| Mnemonic               | Function                    | Format and Devices           |
|------------------------|-----------------------------|------------------------------|
| PLS<br>(Pulse)         | Rising edge pulse           | Devices: Y, M, S, T, C, Dn.m |
| PLF<br>(Pulse Falling) | Falling/trailing edge pulse | Devices: Y, M, S, T, C, Dn.m |

**Statements**

- When a PLS instruction is executed, object devices Y and M operate for one operation cycle after the drive input signal has turned ON.
- When a PLF instruction is executed, object devices Y and M operate for one operation cycle after the drive input signal has turned OFF.

**Program**

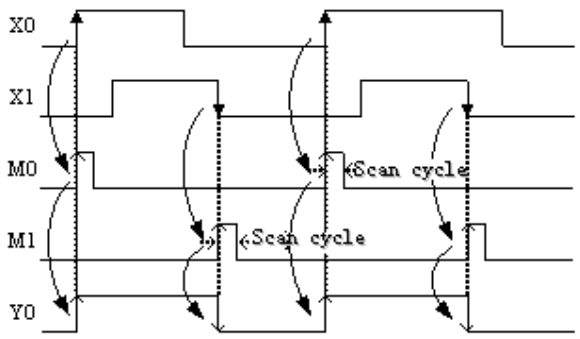
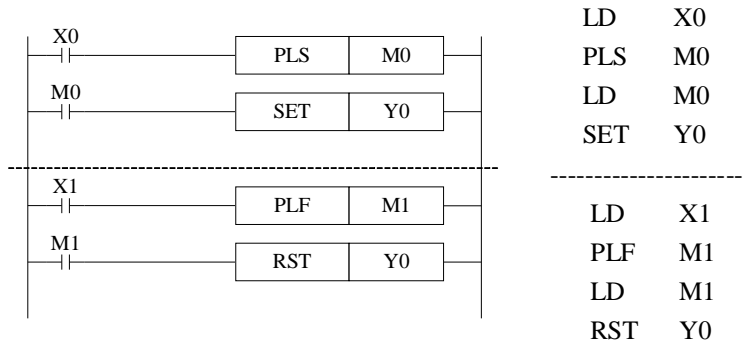

### 3-12. [SET], [RST]

#### Mnemonic and Function

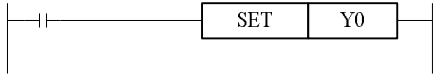
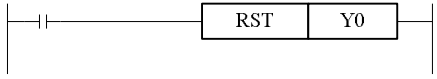
| Mnemonic   | Function                           | Format and Devices  |
|------------|------------------------------------|---|
| SET (Set)  | Set a bit device permanently ON    | <br>Devices: Y、M、S、T、C、Dn.m |
| RST(Reset) | Reset a bit device permanently OFF | <br>Devices: Y、M、S、T、C、Dn.m |

#### Statements

- Turning ON X010 causes Y000 to turn ON. Y000 remains ON even after X010 turns OFF. Turning ON X011 causes Y000 to turn OFF. Y000 remains OFF even after X011 turns OFF. It's the same with M、S.
- SET and RST instructions can be used for the same device as many times as necessary. However, the last instruction activated determines the current status.
- Besides, it's also possible to use RST instruction to reset the current contents of timer, counter and contacts.
- When use SET, RST commands, avoid to use the same ID with OUT command;

#### Program

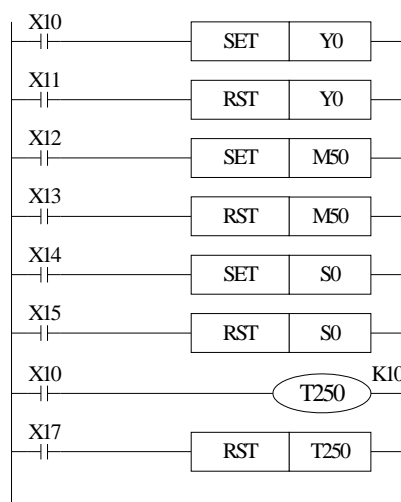

```

LD    X10
SET   Y0
LD    X11
RST   Y0
LD    X12
SET   M50
LD    X13
RST   M50
LD    X14
RST   S0
LD    X15
SET   S0
LD    X17
RST   S0
LD    X10
OUT   T250    K10
LD    X17
RST   T250
  
```

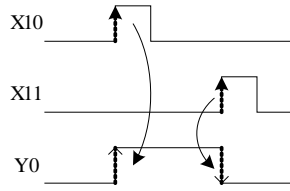

**3-13. 【OUT】 , 【RST】 for the counters**

**Mnemonic and Function**

| Mnemonic | Function                              | Format and Devices |
|----------|---------------------------------------|--------------------|
| OUT      | Final logic operation type coil drive | Device: K、D        |
| RST      | Reset a bit device permanently OFF    | Device: C          |

**Programming of interior counter**

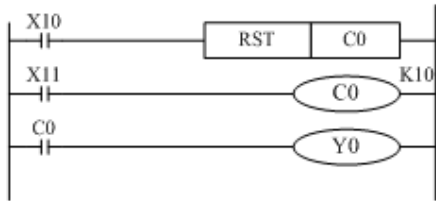

Counter used for power cut retentive. Even when power is cut, hold the current value and output contact's action status and reset status.

C0 carries on increase count for the OFF→ON of X011. When reach the set value K10, output contact C0 activates. Afterwards, even X011 turns from OFF to ON, counter's current value will not change, output contact keep on activating.

To clear this, let X010 be the activate status and reset the output contact. It's necessary to assign constant K or indirect data register's ID behind OUT instruction.

**Programming of high speed counter**

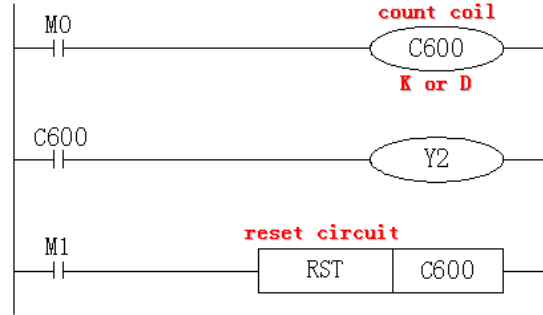

- In the preceding example, when M0 is ON, carry on positive count with OFF→ON of X0.
- Counter's current value increase, when reach the set value (K or D), the output contact is reset.
- When M1 is ON, counter's C600 output contact is reset, counter's current value turns to be 0.

**3-14. [END]**

**Mnemonic and Function**

| Mnemonic     | Function                              | Format and Devices: None |
|--------------|---------------------------------------|--------------------------|
| END<br>(END) | Force the current program scan to end | Devices: None            |

**Statements**

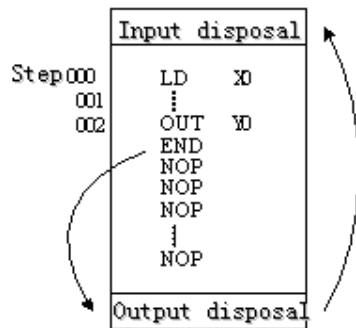

PLC repeatedly carry on input disposal, program executing and output disposal. If write END instruction at the end of the program, then the instructions behind END instruction won't be executed. If there's no END instruction in the program, the PLC executes the end step and then repeat executing the program from step 0. When debug, insert END in each program segment to check out each program's action. Then, after confirm the correction of preceding block's action, delete END instruction. Besides, the first execution of RUN begins with END instruction.

When executing END instruction, refresh monitor timer. (Check if scan cycle is a long timer.)

### 3-15. [GROUP], [GROUPE]

#### Mnemonic and Function

| Mnemonic | Function  | Format and Device |
|----------|-----------|-------------------|
| GROUP    | GROUP     | Devices: None     |
| GROUPE   | GROUP END | Devices: None     |

#### Statements

- GROUP and GROUPE should used in pairs.
- GROUP and GROUPE don't have practical meaning; they are used to optimize the program structure. So, add or delete these instructions doesn't affect the program's running;
- The using method of GROUP and GROUPE is similar with flow instructions; enter GROUP instruction at the beginning of group part; enter GROUPE instruction at the end of group part.

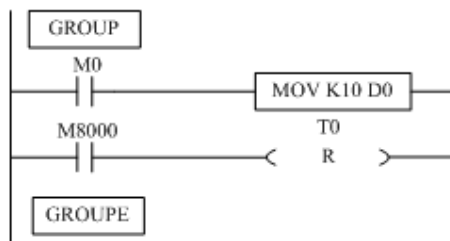

Generally, GROUP and GROUPE instruction can be programmed according to the group's function. Meantime, the programmed instructions can be FOLDED or UNFOLDED. To a redundant project, these two instructions are quite useful.

### 3-16. Items to Note When Programming

#### 1、 Contacts' structure and step number

Even in the sequential control circuit with the same action, it's also available to simple the program and save program's steps according to the contacts' structure.

General program principle is:

- (a) Write the circuit with many serial contacts on the top;
- (b) Write the circuit with many parallel contacts in the left.

#### 2、 Program's executing sequence

Handle the sequential control program by 【From top to bottom】 and 【From left to right】

Sequential control instructions also encode following this flow.

#### 3、 Dual output dual coil's activation and the solution

- If carry on coil's dual output (dual coil) in the sequential control program, then the backward action is prior.
- Dual output (dual coil) doesn't go against the input rule at the program side. But as the preceding action is very complicate, please modify the program as in the following example.

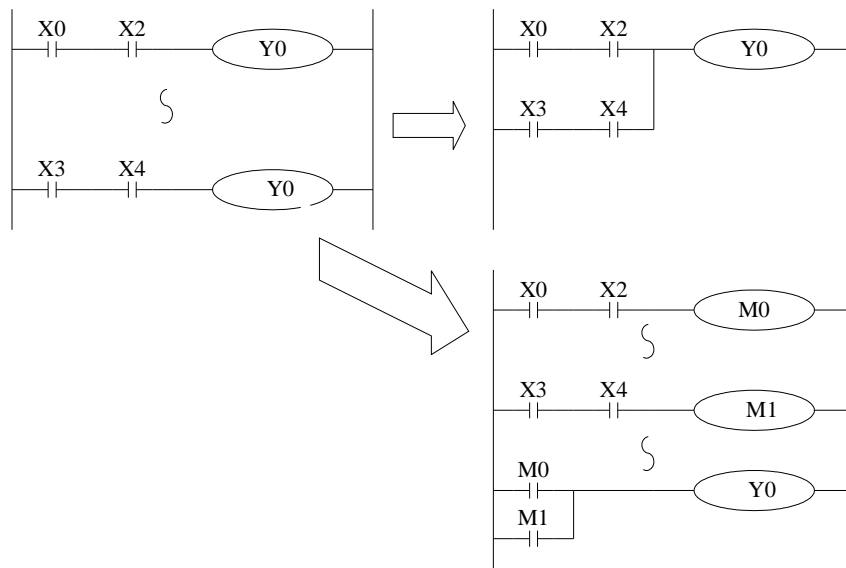

There are other methods. E.g. jump instructions or step ladder. However, when use step ladder, if the main program's output coil is programmed, then the disposal method is the same with dual coil, please note this.

---

# 4 Applied Instructions

---

In this chapter, we describe applied instruction's function of XC series PLC.

4-1. Table of Applied Instructions

4-2. Reading Method of Applied Instructions

4-3. Flow Instructions

4-4. Contactors Compare Instructions

4-5. Move Instructions

4-6. Arithmetic and Logic Operation Instructions





4-7. Loop and Shift Instructions

4-8. Data Convert



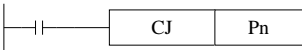

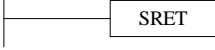
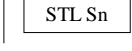
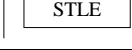
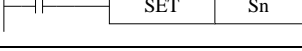
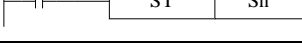
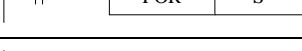
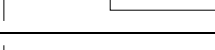
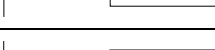
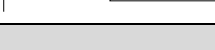
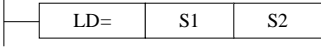
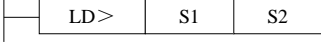
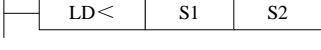
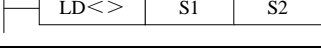
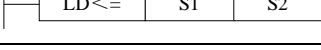
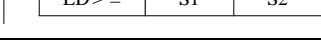

4-9. Floating Operation

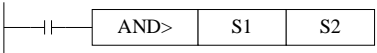
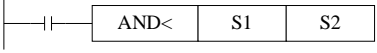
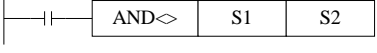
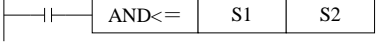
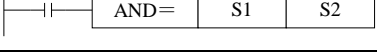
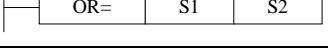
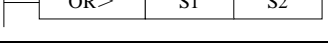
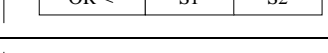
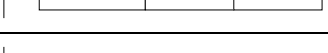
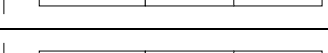
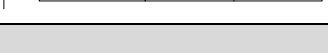
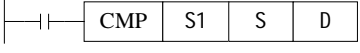
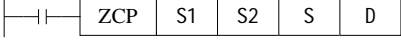
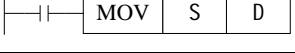
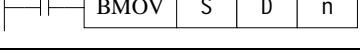
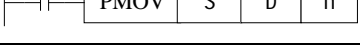
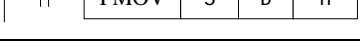
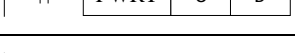
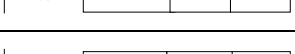
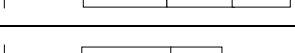
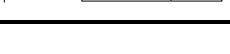
4-10. Clock Operation

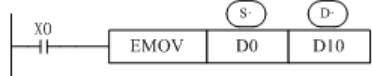
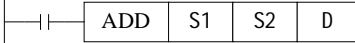
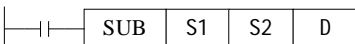
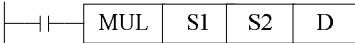
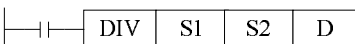
## 4-1. Applied Instruction List

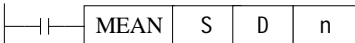
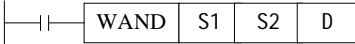
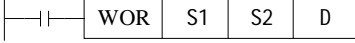
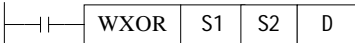
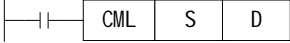
| Mnemonic            | Function   | Ladder chart   | Chapter |
|---------------------|--|--|---------|
| <b>Program Flow</b> |  |  |         |
| CJ                  | Condition jump                                     |    | 4-3-1   |
| CALL                | Call subroutine                                    |    | 4-3-2   |
| SRET                | Subroutine return                                  |    | 4-3-2   |
| STL                 | Flow start   |     | 4-3-3   |
| STLE                | Flow end   |     | 4-3-3   |
| SET                 | Open the assigned flow, close the current flow     |    | 4-3-3   |
| ST                  | Open the assigned flow, not close the current flow |    | 4-3-3   |
| FOR                 | Start a FOR-NEXT loop                              |  | 4-3-4   |
| NEXT                | End of a FOR-NEXT loop                             |  | 4-3-4   |
| FEND                | Main program END                                   |  | 4-3-5   |
| END                 | Program END  |  | 4-3-5   |
| <b>Data Compare</b> |  |  |         |
| LD=                 | LD activates if (S1) = (S2)                        |  | 4-4-1   |
| LD>                 | LD activates if (S1) > (S2)                        |  | 4-4-1   |
| LD<                 | LD activates if (S1) < (S2)                        |  | 4-4-1   |
| LD<>                | LD activates if (S1) ≠ (S2)                        |  | 4-4-1   |
| LD<=                | LD activates if (S1) ≤ (S2)                        |  | 4-4-1   |
| LD>=                | LD activates if (S1) ≥ (S2)                        |  | 4-4-1   |
| AND=                | AND activates if (S1) = (S2)                       |  | 4-4-2   |

|                  |                                  |  |        |
|------------------|----------------------------------|--|--------|
| AND>             | AND activates if (S1) > (S2)     |    | 4-4-2  |
| AND<             | AND activates if (S1) < (S2)     |    | 4-4-2  |
| AND<>            | AND activates if (S1) ≠ (S2)     |    | 4-4-2  |
| AND<=            | AND activates if (S1) ≤ (S2)     |    | 4-4-2  |
| AND>=            | AND activates if (S1) ≥ (S2)     |    | 4-4-2  |
| OR=              | OR activates if (S1) = (S2)      |    | 4-4-3  |
| OR>              | OR activates if (S1) > (S2)      |    | 4-4-3  |
| OR<              | OR activates if (S1) < (S2)      |    | 4-4-3  |
| OR<>             | OR activates if (S1) ≠ (S2)      |    | 4-4-3  |
| OR<=             | OR activates if (S1) ≤ (S2)      |   | 4-4-3  |
| OR>=             | OR activates if (S1) ≥ (S2)      |  | 4-4-3  |
| <b>Data Move</b> |                                  |  |        |
| CMP              | Compare the data                 |  | 4-5-1  |
| ZCP              | Compare the data in certain area |  | 4-5-2  |
| MOV              | Move                             |  | 4-5-3  |
| BMOV             | Block move                       |  | 4-5-4  |
| PMOV             | Transfer the Data block          |  | 4-5-5  |
| FMOV             | Multi-points repeat move         |  | 4-5-6  |
| FWRT             | Flash ROM written                |  | 4-5-7  |
| MSET             | Zone set                         |  | 4-5-8  |
| ZRST             | Zone reset                       |  | 4-5-9  |
| SWAP             | Swap the high and low byte       |  | 4-5-10 |

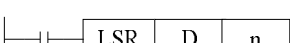
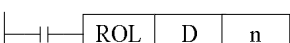
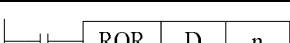
|                       |                        |  |        |
|-----------------------|------------------------|--|--------|
| XCH                   | Exchange two values    |    | 4-5-11 |
| EMOV                  | Float move             |    | 4-5-12 |
| <b>Data Operation</b> |                        |  |        |
| ADD                   | Addition               |    | 4-6-1  |
| SUB                   | Subtraction            |    | 4-6-2  |
| MUL                   | Multiplication         |    | 4-6-3  |
| DIV                   | Division               |    | 4-6-4  |
| INC                   | Increment              |    | 4-6-5  |
| DEC                   | Decrement              |    | 4-6-5  |
| MEAN                  | Mean                   |    | 4-6-6  |
| WAND                  | Word And               |   | 4-6-7  |
| WOR                   | Word OR                |  | 4-6-7  |
| WXOR                  | Word exclusive OR      |  | 4-6-7  |
| CML                   | Compliment             |  | 4-6-8  |
| NEG                   | Negative               |  | 4-6-9  |
| <b>Data Shift</b>     |                        |  |        |
| SHL                   | Arithmetic Shift Left  |  | 4-7-1  |
| SHR                   | Arithmetic Shift Right |  | 4-7-1  |
| LSL                   | Logic shift left       |  | 4-7-2  |
| LSR                   | Logic shift right      |  | 4-7-2  |
| ROL                   | Rotation shift left    |  | 4-7-3  |
| ROR                   | Rotation shift right   |  | 4-7-3  |

|                              |   |  |        |
|------------------------------|---|--|--------|
| SFTL                         | Bit shift left                                      |  | 4-7-4  |
| SFTR                         | Bit shift right                                     |  | 4-7-5  |
| WSFL                         | Word shift left                                     |  | 4-7-6  |
| WSFR                         | Word shift right                                    |  | 4-7-7  |
| <b>Data Convert</b>          |   |  |        |
| WTD                          | Single word integer converts to double word integer |  | 4-8-1  |
| FLT                          | 16 bits integer converts to float point             |  | 4-8-2  |
| DFLT                         | 32 bits integer converts to float point             |  | 4-8-2  |
| FLTD                         | 64 bits integer converts to float point             |  | 4-8-2  |
| INT                          | Float point converts to integer                     |  | 4-8-3  |
| BIN                          | BCD converts to binary                              |  | 4-8-4  |
| BCD                          | Binary converts to BCD                              |  | 4-8-5  |
| ASCI                         | Hex. converts to ASCII                              |  | 4-8-6  |
| HEX                          | ASCII converts to Hex.                              |  | 4-8-7  |
| DECO                         | Coding  |  | 4-8-8  |
| ENCO                         | High bit coding                                     |  | 4-8-9  |
| ENCOL                        | Low bit coding                                      |  | 4-8-10 |
| <b>Float Point Operation</b> |   |  |        |
| ECMP                         | Float compare                                       |  | 4-9-1  |
| EZCP                         | Float Zone compare                                  |  | 4-9-2  |
| EADD                         | Float Add   |  | 4-9-3  |
| ESUB                         | Float Subtract                                      |  | 4-9-4  |

|                 |                      |  |        |
|-----------------|----------------------|--|--------|
| EMUL            | Float Multiplication |    | 4-9-5  |
| EDIV            | Float division       |    | 4-9-6  |
| ESQR            | Float Square Root    |    | 4-9-7  |
| SIN             | Sine                 |    | 4-9-8  |
| COS             | Cosine               |    | 4-9-9  |
| TAN             | Tangent              |    | 4-9-10 |
| ASIN            | Floating Sine        |    | 4-9-11 |
| ACOS            | Floating Cosine      |    | 4-9-12 |
| ATAN            | Floating Tangent     |    | 4-9-13 |
| Clock Operation |                      |  |        |
| TRD             | Read RTC data        |    | 4-10-1 |
| TWR             | Write RTC data       |  | 4-10-2 |

## 4-2. Reading Method of Applied Instructions

In this manual, the applied instructions are described in the following manner.

### 1. Summary

| ADDITION [ADD]       |                                      |                      |                     |
|----------------------|--------------------------------------|----------------------|---------------------|
| 16 bits              | ADD                                  | 32 bits              | DADD                |
| Execution condition  | Normally ON/OFF, Rising/Falling edge | Suitable Models      | XC1.XC2.XC3.XC5.XCM |
| Hardware requirement | -                                    | Software requirement | -                   |

### 2. Operands

| Operands | Function                              | Data Type            |
|----------|---------------------------------------|----------------------|
| S1       | Specify the augends data or register  | 16 bits/32 bits, BIN |
| S2       | Specify the summand data or register  | 16 bits/32 bits, BIN |
| D        | Specify the register to store the sum | 16 bits/32 bits, BIN |

### 3. Suitable Soft Components

| Word | operands | System |    |    |    |    |    |    |    | Constant | Module |    |    |
|------|----------|--------|----|----|----|----|----|----|----|----------|--------|----|----|
|      |          | D      | FD | ED | TD | CD | DX | DY | DM | DS       | K/H    | ID | QD |
|      | S1       | •      | •  |    | •  | •  | •  | •  | •  | •        |        |    |    |
|      | S2       | •      | •  |    | •  | •  | •  | •  | •  | •        |        |    |    |
|      | D        | •      | •  |    | •  | •  |    | •  | •  | •        |        |    |    |

| Bit | Operands | System |   |   |   |   |   |     |
|-----|----------|--------|---|---|---|---|---|-----|
|     |          | X      | Y | M | S | T | C | Dnm |
|     |          |        |   |   |   |   |   |     |

#### Description

<16 bits instruction>



$$(D10) + (D12) \rightarrow (D14)$$

<32 bits instruction>

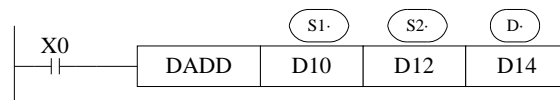

$$(D11D10) + (D13D12) \rightarrow (D15D14)$$



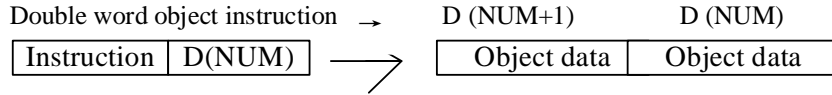

- The denote way of 32 bits instruction  
 If an instruction can not only be 16 bits but also be 32 bits, then the denote method for 32 bits instruction is to add a “D” before 16 bits instruction.  
 E.g: ADD D0 D2 D4 denotes two 16 bits data adds  
 DADD D10 D12 D14 denotes two 32 bits data adds

- 
- ※1: Flag after executing the instruction, instructions without the direct flag will not display.
  - ※2: (S) Source operand, its content won't change after executing the instruction
  - ※3: (D) Destinate operand, its content changes with the execution of the instruction
  - ※4: Tell the instruction's basic action, using way, applied example, extend function, note items etc.
- 

### 4-3. Program Flow Instructions

| Mnemonic | Instruction's name   | Chapter |
|----------|--|---------|
| CJ       | Condition Jump   | 4-3-1   |
| CALL     | Call subroutine  | 4-3-2   |
| SRET     | Subroutine return  | 4-3-2   |
| STL      | Flow start   | 4-3-3   |
| STLE     | Flow end   | 4-3-3   |
| SET      | Open the assigned flow, close the current flow (flow jump)             | 4-3-3   |
| ST       | Open the assigned flow, not close the current flow (Open the new flow) | 4-3-3   |
| FOR      | Start of a FOR-NEXT loop   | 4-3-4   |
| NEXT     | End of a FOR-NEXT loop   | 4-3-4   |
| FEND     | First End  | 4-3-5   |
| END      | Program End  | 4-3-5   |

### 4-3-1. Condition Jump [CJ]

#### 1. Summary

As used to run a part of program, CJ shorten the operation cycle and using the dual coil

| Condition Jump [CJ]  |                      |                      |                     |
|----------------------|----------------------|----------------------|---------------------|
| 16 bits              | CJ                   | 32 bits              | -                   |
| Execution condition  | Normally ON/OFF coil | Suitable Models      | XC1.XC2.XC3.XC5.XCM |
| Hardware requirement | -                    | Software requirement | -                   |

#### 2. Operands

| Operands | Function   | Data Type     |
|----------|--|---------------|
| Pn       | Jump to the target (with pointer Nr.) P (P0~P9999) | Pointer's Nr. |

#### 3. Suitable Soft Components

|       |         |   |
|-------|---------|---|
| Other | Pointer |   |
|       | P       | I |
|       | •       |   |
|       |         |   |

#### Description

In the below graph, if X000 is "ON", jump from the first step to the next step behind P6 tag. If X000 "OFF", do not execute the jump construction;

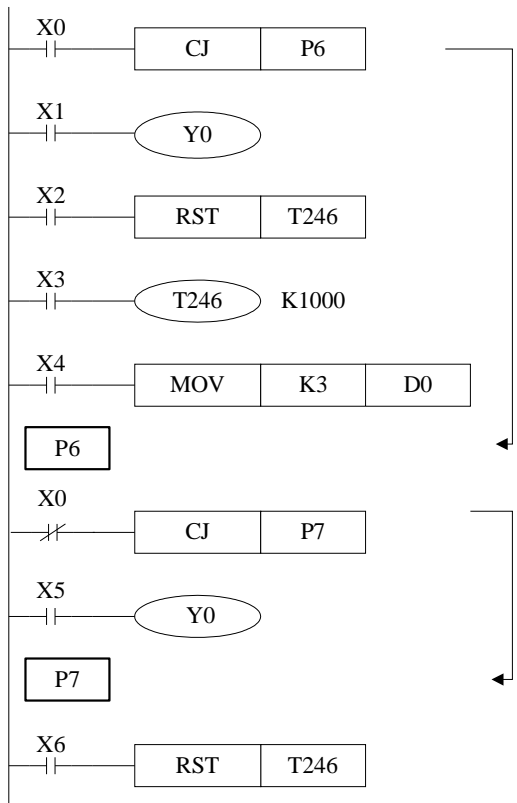

- In the left graph, Y000 becomes to be dual coil output, but when X000=OFF, X001 activates; when X000=ON, X005 activates
- CJ can't jump from one STL to another STL;
- After driving time T0~T640 and HSC C600~C640, if execute CJ, continue to work, the output activates.

**4-3-2. Call subroutine [CALL] and Subroutine return [SRET]**

1. Summary

Call the programs which need to be executed together, decrease the program's steps;

| Subroutine Call [CALL]   |                                      |                      |                     |
|--------------------------|--------------------------------------|----------------------|---------------------|
| 16 bits                  | CALL                                 | 32 bits              | -                   |
| Execution condition      | Normally ON/OFF, Rising/Falling edge | Suitable Models      | XC1.XC2.XC3.XC5.XCM |
| Hardware requirement     | -                                    | Software requirement | -                   |
| Subroutine Return [SRET] |                                      |                      |                     |
| 16 bits                  | SRET                                 | 32 bits              | -                   |
| Execution condition      | -                                    | Suitable Models      | XC1.XC2.XC3.XC5.XCM |
| Hardware requirement     | -                                    | Software requirement | -                   |

## 2. Operands

| Operands | Function   | Data Type     |
|----------|--|---------------|
| Pn       | Jump to the target (with pointer Nr.) P (P0~P9999) | Pointer's Nr. |

## 3. Suitable Soft Components

| Others  | <table border="1" style="margin-left: auto; margin-right: auto;"> <tr> <th colspan="2">Pointer</th> </tr> <tr> <td>P</td> <td>I</td> </tr> <tr> <td>•</td> <td></td> </tr> </table> | Pointer |  | P | I | • |  |
|---------|---|---------|--|---|---|---|--|
| Pointer |   |         |  |   |   |   |  |
| P       | I   |         |  |   |   |   |  |
| •       |   |         |  |   |   |   |  |

### Description

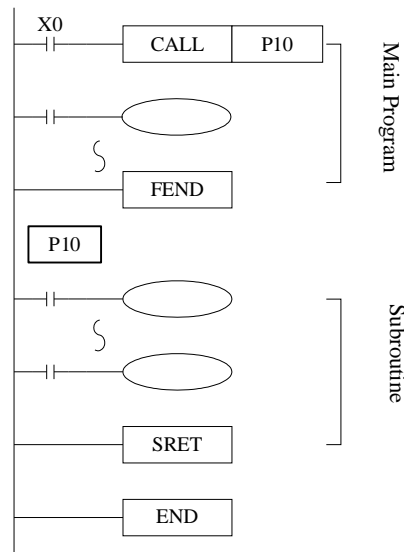

- If X000= “ON”, execute the call instruction and jump to the step tagged by P10. After executing the subroutine, return the original step via SRET instruction. Program the tag with FEND instruction (will describe this instruction later)
- In the subroutine 9 times call is allowed, so totally there can be 10 nestings.

## 4-3-3. Flow [SET]. [ST]. [STL]. [STLE]

### 1、 Summary

Instructions to specify the start, end, open, close of a flow;

| Open the specified flow, close the local flow [SET]    |                                      |                      |                     |
|--|--------------------------------------|----------------------|---------------------|
| 16 bits  | SET                                  | 32 bits              | -                   |
| Execution condition                                    | Normally ON/OFF, Rising/Falling edge | Suitable Models      | XC1.XC2.XC3.XC5.XCM |
| Hardware requirement                                   | -                                    | Software requirement | -                   |
| Open the specified flow, not close the local flow [ST] |                                      |                      |                     |
| 16 bits  | ST                                   | 32 bits              | -                   |
| Execution  | Normally ON/OFF,                     | Suitable             | XC1.XC2.XC3.XC5.XCM |

|                      |                     |                      |                     |
|----------------------|---------------------|----------------------|---------------------|
| condition            | Rising/Falling edge | Models               |                     |
| Hardware requirement | -                   | Software requirement | -                   |
| Flow starts [STL]    |                     |                      |                     |
| 16 bits              | STL                 | 32 bits              | -                   |
| Execution condition  | -                   | Suitable Models      | XC1.XC2.XC3.XC5.XCM |
| Hardware requirement | -                   | Software requirement | -                   |
| Flow ends [STLE]     |                     |                      |                     |
| 16 bits              | STLE                | 32 bits              | -                   |
| Execution condition  | -                   | Suitable Models      | XC1.XC2.XC3.XC5.XCM |
| Hardware requirement | -                   | Software requirement | -                   |

## 2. Operands

|          |                           |           |
|----------|---------------------------|-----------|
| Operands | Function                  | Data Type |
| Sn       | Jump to the target flow S | Flow ID   |

## 3. Suitable Soft Components

|     |          |        |   |   |   |   |   |
|-----|----------|--------|---|---|---|---|---|
| Bit | Operands | System |   |   |   |   |   |
|     |          | X      | Y | M | S | T | C |
|     | Sn       |        |   |   | • |   |   |

### Description

- STL and STLE should be used in pairs. STL represents the start of a flow; STLE represents the end of a flow.
- After executing of **SET Sxxx** instruction, the flow specified by these instructions is ON.
- After executing **RST Sxxx** instruction, the specified flow is OFF.
- In flow S0, SET S1 closes the current flow S0, open flow S1.
- In flow S0, ST S2 opens the flow S2, but don't close flow S0.
- When flow turns from ON to be OFF, reset OUT、PLS、PLF、 not accumulate timer etc, which belong to the flow.
- ST instruction is usually used when a program needs to run more flows at the same time.
- After executing of **SET Sxxx** instruction, the pulse instructions will be closed (including one-segment, multi-segment, relative or absolute, return to the origin)

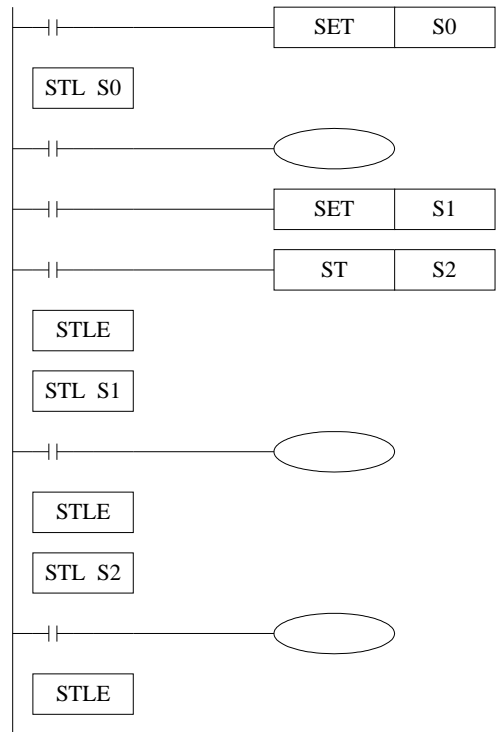

**4-3-4. [FOR] and [NEXT]**

1. Summary

Loop execute the program between **FOR** and **NEXT** with the specified times;

|                      |                                      |                      |                     |
|----------------------|--------------------------------------|----------------------|---------------------|
| Loop starts [FOR]    |                                      |                      |                     |
| 16 bits              | FOR                                  | 32 bits              | -                   |
| Execution condition  | Rising/Falling edge                  | Suitable Models      | XC1.XC2.XC3.XC5.XCM |
| Hardware requirement | -                                    | Software requirement | -                   |
| Loop ends [NEXT]     |                                      |                      |                     |
| 16 bits              | NEXTs                                | 32 bits              | -                   |
| Execution condition  | Normally ON/OFF, Rising/Falling edge | Suitable Models      | XC1.XC2.XC3.XC5.XCM |
| Hardware requirement | -                                    | Software requirement | -                   |

2. Operands

| Operands | Function                              | Data Type    |
|----------|---------------------------------------|--------------|
| S        | Program's loop times between FOR~NEXT | 16 bits, BIN |

### 3. Suitable Soft Components

| Word | Operands | System |    |    |    |    |    |    |    | Constant | Module |    |    |
|------|----------|--------|----|----|----|----|----|----|----|----------|--------|----|----|
|      |          | D      | FD | ED | TD | CD | DX | DY | DM | DS       | K/H    | ID | QD |
| S    | •        |        |    |    |    |    |    |    |    |          | •      |    |    |

#### Description

- FOR.NEXT instructions must be programmed as a pair. Nesting is allowed, and the nesting level is 8.
- Between FOR/NEXT, LDP.LDF instructions are effective for one time. Every time when M0 turns from OFF to ON, and M1 turns from OFF to ON, [A] loop is executed 6 times.
- Every time if M0 turns from OFF to ON and M3 is ON, [B] loop is executed 5×7=35 times.
- If there are many loop times, the scan cycle will be prolonged. Monitor timer error may occur, please note this.
- If NEXT is before FOR, or no NEXT, or NEXT is behind FENG, END, or FOR and NEXT number is not equal, an error will occur.
- Between FOR~NEXT, CJ nesting is not allowed, also in one STL, FOR~NEXT must be programmed as a pair.

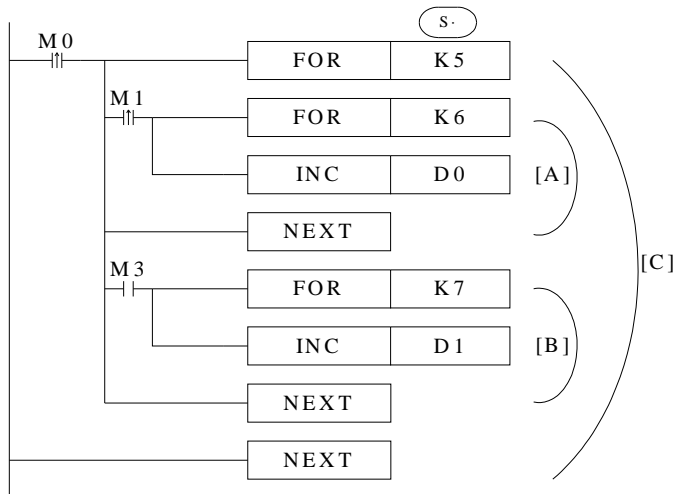

#### 4-3-5. [FEND] and [END]

##### 1. Summary

FEND means the main program ends, while END means program ends;

| main program ends [FEND] |   |                      |                     |
|--------------------------|---|----------------------|---------------------|
| Execution condition      | - | Suitable Models      | XC1.XC2.XC3.XC5.XCM |
| Hardware requirement     | - | Software requirement | -                   |
| program ends [END]       |   |                      |                     |
| Execution condition      | - | Suitable Models      | XC1.XC2.XC3.XC5.XCM |
| Hardware requirement     | - | Software requirement | -                   |

##### 2. Operands

| Operands | Function | Data Type |
|----------|----------|-----------|
| None     | -        | -         |

##### 3. Suitable Soft Components

|      |
|------|
| None |
|------|

##### Description

Even though [FEND] instruction represents the end of the main program, if execute this instruction, the function is same with END. Execute the output/input disposal, monitor the refresh of the timer, and return to the 0th step.

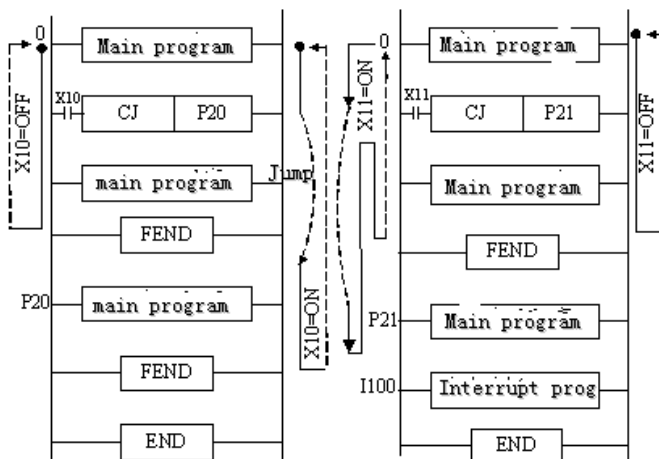

- If program the tag of CALL instruction behind FEND instruction, there must be SRET instruction. If the interrupt pointer program behind FEND instruction, there must be IRET instruction.

- After executing CALL instruction and before executing SRET instruction, if execute FEND instruction; or execute FEND instruction after executing FOR instruction and before executing NEXT, then an error will occur.
- In the condition of using many FEND instruction, please compile routine or subroutine between the last FEND instruction and END instruction.

#### 4-4. Data compare function

| Mnemonic | Function                     | Chapter |
|----------|------------------------------|---------|
| LD=      | LD activates when (S1)=(S2)  | 4-4-1   |
| LD>      | LD activates when (S1)>(S2)  | 4-4-1   |
| LD<      | LD activates when (S1)<(S2)  | 4-4-1   |
| LD<>     | LD activates when (S1)≠(S2)  | 4-4-1   |
| LD<=     | LD activates when (S1)≤(S2)  | 4-4-1   |
| LD>=     | LD activates when (S1)≥(S2)  | 4-4-1   |
| AND=     | AND activates when (S1)=(S2) | 4-4-2   |
| AND>     | AND activates when (S1)>(S2) | 4-4-2   |
| AND<     | AND activates when (S1)<(S2) | 4-4-2   |
| AND<>    | AND activates when (S1)≠(S2) | 4-4-2   |
| AND<=    | AND activates when (S1)≤(S2) | 4-4-2   |
| AND>=    | AND activates when (S1)≥(S2) | 4-4-2   |
| OR=      | OR activates when (S1)=(S2)  | 4-4-3   |
| OR>      | OR activates when (S1)>(S2)  | 4-4-3   |
| OR<      | OR activates when (S1)<(S2)  | 4-4-3   |
| OR<>     | OR activates when (S1)≠(S2)  | 4-4-3   |
| OR<=     | OR activates when (S1)≤(S2)  | 4-4-3   |
| OR>=     | OR activates when (S1)≥(S2)  | 4-4-3   |

#### 4-4-1. LD Compare [LD□]

##### 1. Summary

LD□ is the point compare instruction connected with the generatrix.

| LD Compare [LD□]     |          |                      |                     |
|----------------------|----------|----------------------|---------------------|
| 16 bits              | As below | 32 bits              | As below            |
| Execution condition  | -        | Suitable Models      | XC1.XC2.XC3.XC5.XCM |
| Hardware requirement | -        | Software requirement | -                   |

## 2. Operands

| Operands | Function  | Data Type       |
|----------|---|-----------------|
| S1       | Specify the Data ( to be compared) or soft component's address code | 16/32bits, BIN  |
| S2       | Specify the component value or soft component's address code        | 16/32 bits, BIN |

## 3. Suitable soft components

| Word | Operands | System |    |    |    |    |    |    |    |    | Constant | Module |    |
|------|----------|--------|----|----|----|----|----|----|----|----|----------|--------|----|
|      |          | D      | FD | ED | TD | CD | DX | DY | DM | DS | K/H      | ID     | QD |
| S1   |          | •      | •  |    | •  | •  | •  | •  | •  | •  | •        |        |    |
| S2   |          | •      | •  |    | •  | •  | •  | •  | •  | •  | •        |        |    |

### Description

| 16 bits instruction | 32 bits instruction | Activate Condition | Not Activate Condition |
|---------------------|---------------------|--------------------|------------------------|
| LD=                 | DLD=                | (S1)= (S2)         | (S1)≠ (S2)             |
| LD>                 | DLD>                | (S1)> (S2)         | (S1)≤ (S2)             |
| LD<                 | DLD<                | (S1)< (S2)         | (S1)≥ (S2)             |
| LD<>                | DLD<>               | (S1)≠ (S2)         | (S1)= (S2)             |
| LD≤                 | DLD≤                | (S1)≤ (S2)         | (S1)> (S2)             |
| LD≥                 | DLD≥                | (S1)≥ (S2)         | (S1)< (S2)             |

### Note Items

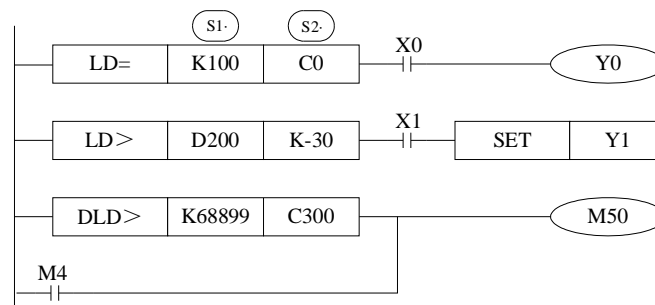

- When the source data's highest bit (16 bits: b15, 32 bits: b31) is 1, use the data as a negative.
- The comparison of 32 bits counter (C300~) must be 32 bits instruction. If assigned as a 16 bits instruction, it will lead the program error or operation error.

## 4-4-2. AND Compare [AND□]

### 1. Summary

AND□: The compare instruction to serial connects with the other contactors.

| AND Compare [AND□]   |                      |                      |                     |
|----------------------|----------------------|----------------------|---------------------|
| 16 bits              | As Below             | 32 bits              | As Below            |
| Execution condition  | Normally ON/OFF coil | Suitable Models      | XC1.XC2.XC3.XC5.XCM |
| Hardware requirement | -                    | Software requirement | -                   |

### 2. Operands

| Operands | Function  | Data Type    |
|----------|---|--------------|
| S1       | Specify the Data ( to be compared) or soft component's address code | 16/32bit,BIN |
| S2       | Specify the comparand's value or soft component's address code      | 16/32bit,BIN |

### 3. Suitable soft components

| Word | Operands | System |    |    |    |    |    |    |    | Constant | Module |    |    |
|------|----------|--------|----|----|----|----|----|----|----|----------|--------|----|----|
|      |          | D      | FD | ED | TD | CD | DX | DY | DM | DS       | K/H    | ID | QD |
| S1   |          | •      | •  |    | •  | •  | •  | •  | •  | •        | •      |    |    |
| S2   |          | •      | •  |    | •  | •  | •  | •  | •  | •        | •      |    |    |

### Description

| 16 bits instruction | 32 bits instruction | Activate Condition | Not Activate Condition |
|---------------------|---------------------|--------------------|------------------------|
| AND=                | DAND=               | (S1)= (S2)         | (S1)≠ (S2)             |
| AND>                | DAND>               | (S1)> (S2)         | (S1)≤ (S2)             |
| AND<                | DAND<               | (S1)< (S2)         | (S1)≥ (S2)             |
| AND<>               | DAND<>              | (S1)≠ (S2)         | (S1)= (S2)             |
| AND<=               | DAND<=              | (S1)≤ (S2)         | (S1)> (S2)             |
| AND>=               | DAND>=              | (S1)≥ (S2)         | (S1)< (S2)             |



**Description**

| 16 bits instruction | 32 bits instruction | Activate Condition | Not Activate Condition |
|---------------------|---------------------|--------------------|------------------------|
| OR=                 | DOR=                | (S1)= (S2)         | (S1)≠ (S2)             |
| OR>                 | DOR>                | (S1)> (S2)         | (S1)≤ (S2)             |
| OR<                 | DOR<                | (S1)< (S2)         | (S1)≥ (S2)             |
| OR<>                | DOR<>               | (S1)≠ (S2)         | (S1)= (S2)             |
| OR<=                | DOR<=               | (S1)≤ (S2)         | (S1)> (S2)             |
| OR>=                | DOR>=               | (S1)≥ (S2)         | (S1)< (S2)             |

**Note Items**

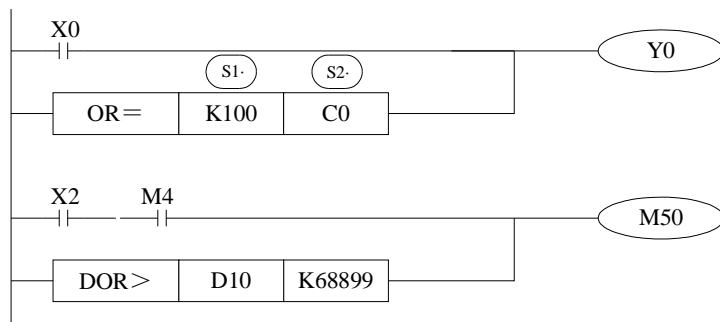

- When the source data's highest bit (16 bits: b15, 32 bits: b31) is 1, use the data as a negative.
- The comparison of 32 bits counter (C300~) must be 32 bits instruction. If assigned as a 16 bits instruction, it will lead the program error or operation error.

**4-5. Data Move**

| Mnemonic | Function                            | Chapter |
|----------|-------------------------------------|---------|
| CMP      | Data compare                        | 4-5-1   |
| ZCP      | Data zone compare                   | 4-5-2   |
| MOV      | Move                                | 4-5-3   |
| BMOV     | Data block move                     | 4-5-4   |
| PMOV     | Data block move (with faster speed) | 4-5-5   |
| FMOV     | Fill move                           | 4-5-6   |
| FWRT     | FlashROM written                    | 4-5-7   |
| MSET     | Zone set                            | 4-5-8   |
| ZRST     | Zone reset                          | 4-5-9   |

|      |   |        |
|------|---|--------|
| SWAP | The high and low byte of the destined devices are exchanged | 4-5-10 |
| XCH  | Exchange  | 4-5-11 |

**4-5-1. Data Compare [CMP]**

1. Summary

Compare the two specified Data, output the result.

| Data compare [CMP]   |                                      |                      |                     |
|----------------------|--------------------------------------|----------------------|---------------------|
| 16 bits              | CMP                                  | 32 bits              | DCMP                |
| Execution condition  | Normally ON/OFF, rising/falling edge | Suitable Models      | XC1.XC2.XC3.XC5.XCM |
| Hardware requirement | -                                    | Software requirement | -                   |

2. Operands

| Operands | Function   | Data Type   |
|----------|--|-------------|
| S1       | Specify the data (to be compared) or soft component's address code | 16 bit, BIN |
| S        | Specify the comparand's value or soft component's address code     | 16 bit, BIN |
| D        | Specify the compare result's address code                          | bit         |

3. Suitable soft component

|      |          |        |    |    |    |    |    |      |    |          |        |    |
|------|----------|--------|----|----|----|----|----|------|----|----------|--------|----|
| Word | Operands | System |    |    |    |    |    |      |    | Constant | Module |    |
|      |          | D      | FD | ED | TD | CD | DX | DY   | DM | DS       | K/H    | ID |
|      | S1       | •      | •  |    | •  | •  | •  | •    | •  | •        |        |    |
|      | S        | •      | •  |    | •  | •  | •  | •    | •  | •        |        |    |
| Bit  | Operands | System |    |    |    |    |    |      |    |          |        |    |
|      |          | X      | Y  | M  | S  | T  | C  | Dn,m |    |          |        |    |
|      | D        |        | •  | •  | •  |    |    |      |    |          |        |    |

**Description**

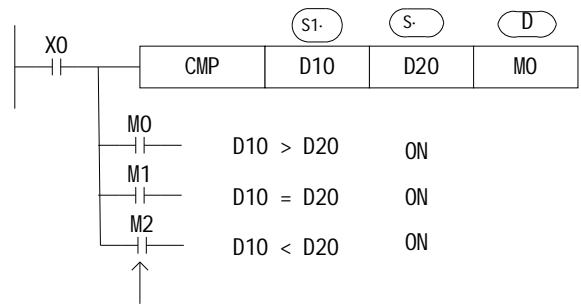

Even X000=OFF to stop ZCP instruction, M0~M2 will keep the original status

- Compare data (S1) and (S) , output the three points' ON/OFF status (start with (D) ) according to the value

(D) , (D) + 1, (D) + 2 : The three point's on/off output according to the valve

**4-5-2. Data zone compare [ZCP]**

1. Summary

Compare the two specify Data with the current data, output the result.

| Data Zone compare [ZCP] |                                      |                      |                     |
|-------------------------|--------------------------------------|----------------------|---------------------|
| 16 bits                 | ZCP                                  | 32 bits              | DZCP                |
| Execution condition     | Normally ON/OFF, rising/falling edge | Suitable Models      | XC1.XC2.XC3.XC5.XCM |
| Hardware requirement    | -                                    | Software requirement | -                   |

2. Operands

| Operands | Function  | Data Type   |
|----------|---|-------------|
| S1       | Specify the down-limit Data (of the compare stand) or soft component's address code | 16 bit, BIN |
| S2       | Specify the Up-limit Data (of the compare stand) or soft component's address code   | 16 bit, BIN |
| S        | Specify the current data or soft component's address code                           | 16 bit, BIN |
| D        | Specify the compare result's data or soft component's address code                  | bit         |

### 3. Suitable soft components

| Word | Operands | System |    |    |    |    |    |    |    | Constant | Module |    |
|------|----------|--------|----|----|----|----|----|----|----|----------|--------|----|
|      | D        | FD     | ED | TD | CD | DX | DY | DM | DS | K/H      | ID     | QD |
| S1   | •        | •      |    | •  | •  | •  | •  | •  | •  | •        |        |    |
| S2   | •        | •      |    | •  | •  | •  | •  | •  | •  | •        |        |    |
| S    | •        | •      |    | •  | •  | •  | •  | •  | •  | •        |        |    |

| Bit | Operands | System |   |   |   |   |      |  |
|-----|----------|--------|---|---|---|---|------|--|
|     | X        | Y      | M | S | T | C | Dn.m |  |
| D   |          | •      | • | • |   |   |      |  |

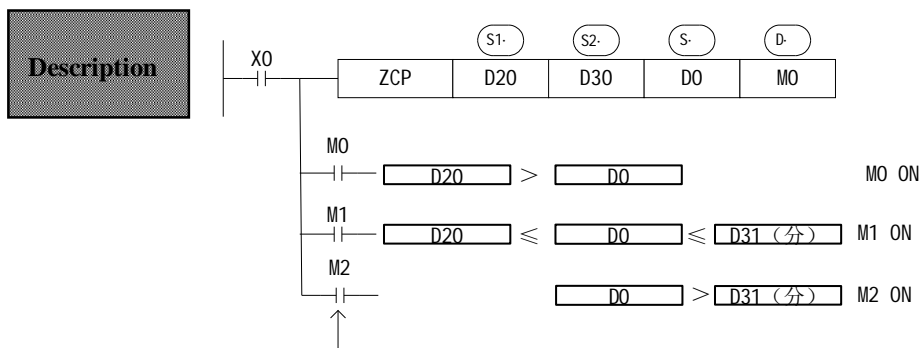

Even X000=OFF stop ZCP instruction, M0~M2 will keep the original status

- Compare (S) data with (S1) and (S2), (D) output the three point's ON/OFF status according to the zone size.
- (D), (D) + 1, (D) + 2 : the three point's ON/OFF output according to the result

### 4-5-3. MOV [MOV]

#### 1. Summary

Move the specified data to the other soft components

| MOV [MOV]            |                                      |                      |                     |
|----------------------|--------------------------------------|----------------------|---------------------|
| 16 bits              | MOV                                  | 32 bits              | DMOV                |
| Execution condition  | Normally ON/OFF, rising/falling edge | Suitable Models      | XC1.XC2.XC3.XC5.XCM |
| Hardware requirement | -                                    | Software requirement | -                   |

## 2. Operands

| Operands | Function   | Data Type          |
|----------|--|--------------------|
| S        | Specify the source data or register's address code | 16 bit/32 bit, BIN |
| D        | Specify the target soft component's address code   | 16 bit/32 bit, BIN |

## 3. Suitable soft component

| Word | Operands | System |    |    |    |    |    |    |    |    | Constant | Module |    |
|------|----------|--------|----|----|----|----|----|----|----|----|----------|--------|----|
|      |          | D      | FD | ED | TD | CD | DX | DY | DM | DS | K/H      | ID     | QD |
| S    |          | •      | •  | •  | •  | •  | •  | •  | •  | •  | •        |        |    |
| D    |          | •      |    | •  | •  | •  |    | •  | •  | •  |          |        |    |

### Description

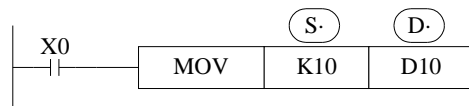

- Move the source data to the target
- When X000 is off, the data keeps same
- Convert constant K10 to be BIN code automatically

<read the counter's or time's current value>

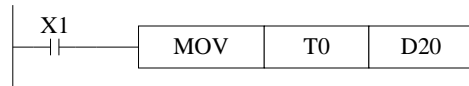

(The current value of T0)→(D20)  
The same as counter

<indirectly specify the counter's, time's set value>

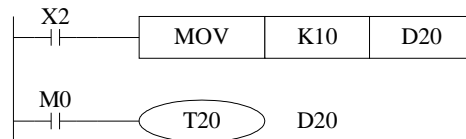

(K10) (D10)  
D20=K10

< Move the 32bits data >

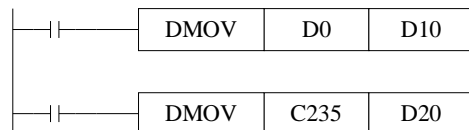

Please use DMOV when the value is 32 bits, such as MUL instruction, high speed counter...

(D1, D0)→(D11, D10)  
(the current value of C235)→(D21, D20)

## 4-5-4. Data block Move [BMOV]

### 1. Summary

Move the specified data block to

| Data block move [BMOV] |                      |                      |                     |
|------------------------|----------------------|----------------------|---------------------|
| 16 bits                | BMOV                 | 32 bits              | -                   |
| Execution condition    | Normally ON/OFF coil | Suitable Models      | XC1.XC2.XC3.XC5.XCM |
| Hardware requirement   | -                    | Software requirement | -                   |

### 2. Operands

| Operands | Function   | Data Type         |
|----------|--|-------------------|
| S        | Specify the source data block or soft component address code | 16 bits, BIN; bit |
| D        | Specify the target soft components address code              | 16 bits, BIN; bit |
| n        | Specify the move data's number                               | 16 bits, BIN;     |

### 3. Suitable soft components

| Word | Operands | System |    |    |    |    |    |    |    | Constant | Module |    |    |
|------|----------|--------|----|----|----|----|----|----|----|----------|--------|----|----|
|      |          | D      | FD | ED | TD | CD | DX | DY | DM | DS       | K/H    | ID | QD |
|      | S        | •      | •  | •  | •  | •  | •  | •  | •  | •        |        |    |    |
|      | D        | •      |    | •  | •  | •  |    | •  | •  | •        |        |    |    |
|      | n        | •      |    |    | •  | •  | •  |    | •  | •        | •      |    |    |

| Bit | Operands | System |   |   |   |   |   |     |
|-----|----------|--------|---|---|---|---|---|-----|
|     |          | X      | Y | M | S | T | C | Dnm |
|     | S        | •      | • | • |   |   |   |     |
|     | D        | •      | • | • |   |   |   |     |

### Description

- Move the specified “n” data to the specified “n” soft components in the form block.

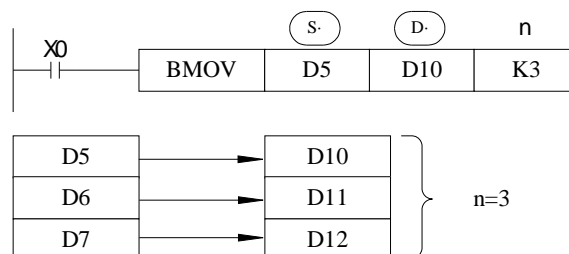

➤ As the following picture, when the data address overlapped, the instruction will do from 1 to 3.

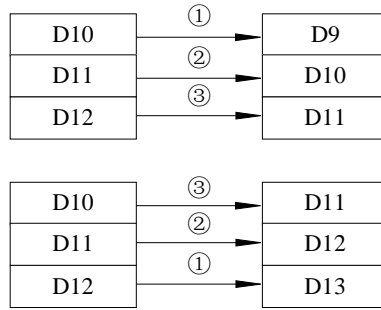
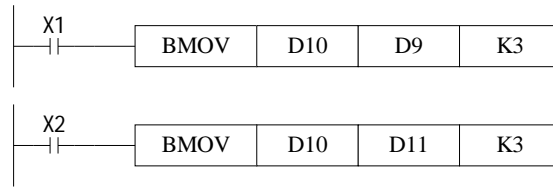

#### 4-5-5. Data block Move [PMOV]

##### 1. Summary

Move the specified data block to the other soft components

| Data block move[PMOV] |                      |                      |                     |
|-----------------------|----------------------|----------------------|---------------------|
| 16 bits               | PMOV                 | 32 bits              | -                   |
| Execution condition   | Normally ON/OFF coil | Suitable Models      | XC1.XC2.XC3.XC5.XCM |
| Hardware requirement  | -                    | Software requirement | -                   |

##### 2. Operands

| Operands | Function   | Data Type         |
|----------|--|-------------------|
| S        | Specify the source data block or soft component address code | 16 bits, BIN; bit |
| D        | Specify the target soft components address code              | 16 bits, BIN; bit |
| n        | Specify the move data's number                               | 16 bits, BIN;     |

### 3. Suitable soft components

| Word | Operands | System |    |    |    |    |    |    |    | Constant | Module |    |    |
|------|----------|--------|----|----|----|----|----|----|----|----------|--------|----|----|
|      |          | D      | FD | ED | TD | CD | DX | DY | DM | DS       | K/H    | ID | QD |
| S    |          | •      | •  | •  | •  | •  | •  | •  | •  | •        |        |    |    |
| D    |          | •      |    | •  | •  | •  |    | •  | •  | •        |        |    |    |
| n    |          | •      |    |    | •  | •  |    | •  | •  | •        | •      |    |    |

| Bit | Operands | system |   |   |   |   |   |     |
|-----|----------|--------|---|---|---|---|---|-----|
|     |          | X      | Y | M | S | T | C | Dnm |
| S   |          | •      | • | • |   |   |   |     |
| D   |          | •      | • | • |   |   |   |     |

#### Description

➤ Move the specified “n” data to the specified “n” soft components in form of block

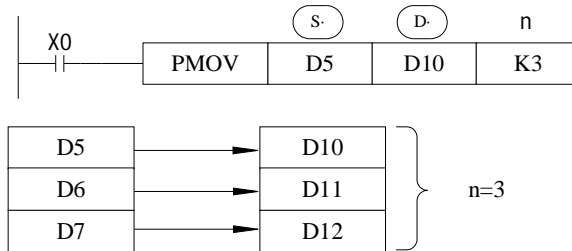

- The function of PMOV and BMOV is mostly the same, but the PMOV has the faster speed
- PMOV finish in one scan cycle, when executing PMOV , close all the interruptions
- Mistake many happen, if there is a repeat with source address and target address

### 4-5-6. Fill Move [FMOV]

#### 1. Summary

Move the specified data block to the other soft components

| Fill Move [FMOV]     |                                      |                      |                     |
|----------------------|--------------------------------------|----------------------|---------------------|
| 16 bits              | FMOV                                 | 32 bits              | DFMOV               |
| Execution condition  | Normally ON/OFF, rising/falling edge | Suitable Models      | XC1.XC2.XC3.XC5.XCM |
| Hardware requirement | DFMOV need above V3.0                | Software requirement | -                   |

## 2. Operands

| Operands | Function   | Data Type         |
|----------|--|-------------------|
| S        | Specify the source data block or soft component address code | 16 bits, BIN; bit |
| D        | Specify the target soft components address code              | 16 bits, BIN; bit |
| n        | Specify the move data's number                               | 16 bits, BIN;     |

## 3. Suitable soft component

| Word | Operands | System |    |    |    |    |    |    |    | Constant | Module |    |    |
|------|----------|--------|----|----|----|----|----|----|----|----------|--------|----|----|
|      |          | D      | FD | ED | TD | CD | DX | DY | DM | DS       | K/H    | ID | QD |
| S    |          | •      | •  | •  | •  | •  | •  | •  | •  | •        | •      |    |    |
| D    |          | •      |    | •  | •  | •  |    | •  | •  | •        |        |    |    |
| n    |          | •      |    |    | •  | •  |    | •  | •  | •        | •      |    |    |

### Description

<16 bits instruction>

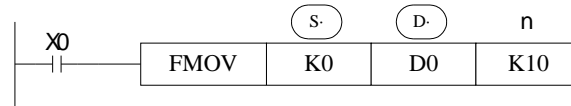

- Move K0 to D0~D9, copy a single data device to a range of destination device
- The data stored in the source device (S) is copied to every device within the destination range, the range is specified by a device head address (D) and a quantity of consecutive elements (n).
- If the specified number of destination devices (n) exceeds the available space at the destination location, then only the available destination devices will be written to.

<32 bits instruction >

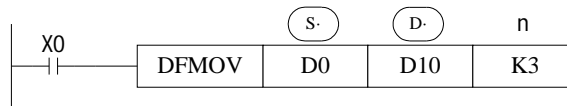

- Move D0.D1 to D10.D11:D12.D13:D14.D15.

---

<16 bits Fill Move >

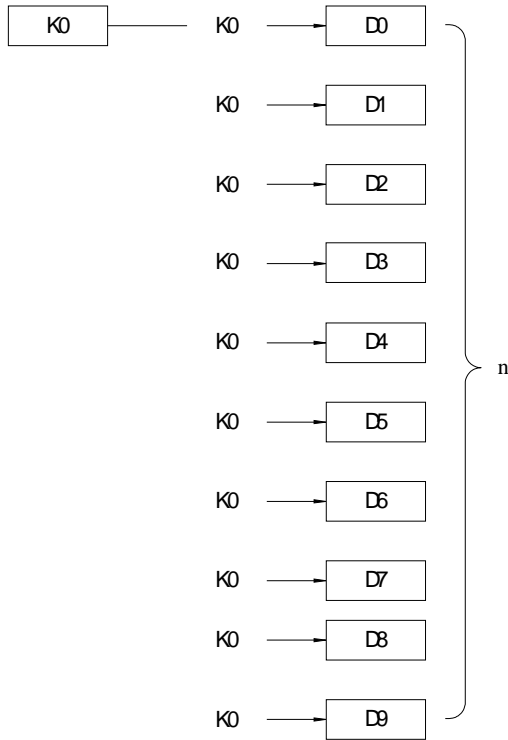

<32 bits Fill move>

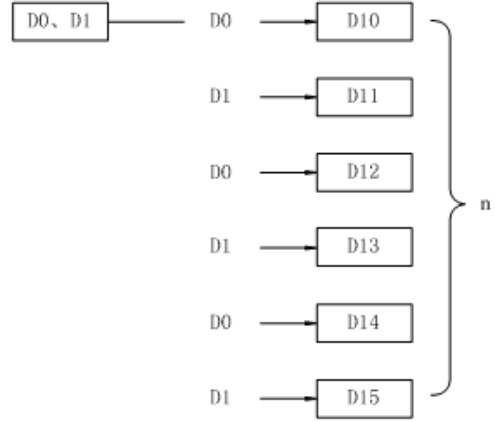

## 4-5-7. FlashROM Write [FWRT]

### 1. Summary

Write the specified data to other soft components

| FlashROM Write [FWRT] |                     |                      |                     |
|-----------------------|---------------------|----------------------|---------------------|
| 16 bits               | FWRT                | 32 bits              | DFWRT               |
| Execution condition   | rising/falling edge | Suitable Models      | XC1.XC2.XC3.XC5.XCM |
| Hardware requirement  | -                   | Software requirement | -                   |

### 2. Operands

| Operands | Function   | Data Type            |
|----------|--|----------------------|
| S        | The data write in the source or save in the soft element | 16 bits/32 bits, BIN |
| D        | Write in target soft element                             | 16 bits/32 bits, BIN |
| D1       | Write in target soft element start address               | 16 bits/32 bits, BIN |
| D2       | Write in data quantity                                   | bit                  |

### 3. Suitable soft components

| Word | Operands | System |    |    |    |    |    |    |    |    | Constant | Module |    |
|------|----------|--------|----|----|----|----|----|----|----|----|----------|--------|----|
|      |          | D      | FD | ED | TD | CD | DX | DY | DM | DS | K/H      | ID     | QD |
| S    |          | •      | •  |    | •  | •  | •  | •  | •  | •  | •        |        |    |
| D    |          |        | •  |    |    |    |    |    |    |    |          |        |    |
| D1   |          |        | •  |    |    |    |    |    |    |    |          |        |    |
| D2   |          | •      |    |    | •  | •  | •  | •  | •  | •  | •        |        |    |



< Written of a word >



<Written of double word>

<Written of multi-word>

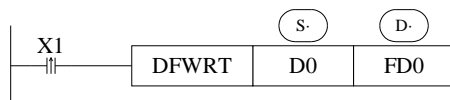

Write value in D0, D1 into FD0, FD1

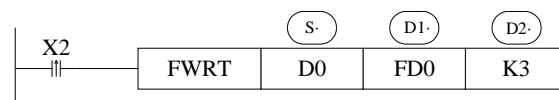

Write value in D0, D1, and D2 into FD0, FD1,

- 
- ※1: FWRT instruction only allows data to write into FlashROM register. In this storage, even battery drop, data could be used to store important technical parameters
  - ※2: Written of FWRT needs a long time, about 150ms, so frequently operate this operate this operate operation is recommended
  - ※3: The written time of FlashROM is about 1,000,000 times. So we suggest using edge signal (LDP, LDF etc.) to trigger.
  - ※4: Frequently written of FlashROM
- 

### 4-5-8. Zone set [MSET]

#### 1. Summary

Set or reset the soft element in certain range

| Multi-set [MSET]     |                 |                      |                     |
|----------------------|-----------------|----------------------|---------------------|
| 16 bits              | MSET.ZRST       | 32 bits              | -                   |
| Execution condition  | Normally ON/OFF | Suitable Models      | XC1.XC2.XC3.XC5.XCM |
| Hardware requirement | -               | Software requirement | -                   |

#### 2. Operands

| Operands | Function                   | Data Type |
|----------|----------------------------|-----------|
| D1       | Start soft element address | bit       |
| D2       | End soft element address   | bit       |

#### 3. Suitable soft components

| Bit | Operands | System |   |   |   |   |   |     |
|-----|----------|--------|---|---|---|---|---|-----|
|     |          | X      | Y | M | S | T | C | Dnm |
| D1  |          | •      | • | • | • | • | • |     |
| D2  |          | •      | • | • | • | • | • |     |

**Description**

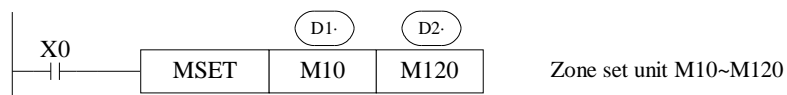

- (D1) (D2) Are specified as the same type of soft units, and (D1) < (D2)
- When (D1) > (D2) will not run Zone set, set M8004.M8067, and D8067=2.

## 4-5-9. Zone reset [ZRST]

### 1. Summary

Reset the soft element in the certain range

| Multi-reset [ZRST]   |                 |                      |                     |
|----------------------|-----------------|----------------------|---------------------|
| 16 bits              | ZRST            | 32 bits              | -                   |
| Execution condition  | Normally ON/OFF | Suitable Models      | XC1.XC2.XC3.XC5.XCM |
| Hardware requirement | -               | Software requirement | -                   |

### 2. Operands

| Operands | Function                      | Data Type         |
|----------|-------------------------------|-------------------|
| D1       | Start address of soft element | Bit: 16 bits, BIN |
| D2       | End address of soft element   | Bit: 16 bits, BIN |

### 3. Suitable soft components

| Word | Operands | System |    |    |    |    |    |    |    | Constant | Module |    |    |
|------|----------|--------|----|----|----|----|----|----|----|----------|--------|----|----|
|      |          | D      | FD | ED | TD | CD | DX | DY | DM | DS       | K/H    | ID | QD |
|      | D1       | •      |    |    |    |    | •  | •  | •  |          |        |    |    |
|      | D2       | •      |    |    |    | •  | •  | •  | •  |          |        |    |    |

| Bit | Operands | System |   |   |   |   |   |     |
|-----|----------|--------|---|---|---|---|---|-----|
|     |          | X      | Y | M | S | T | C | Dnm |
|     | D1       | •      | • | • | • | • | • |     |
|     | D2       | •      | • | • | • | • | • |     |

**Description**

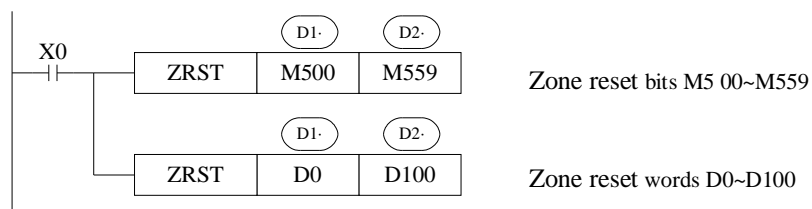

- (D1) (D2) Are specified as the same type of soft units, and (D1) < (D2)
- When (D1) > (D2) only reset the soft unit specified in (D1) , and set M8004. D8067=2.

**Other Reset Instruction**

- As soft unit's separate reset instruction, RST instruction can be used to bit unit Y, M, S and word unit T, C, D
- As fill move for constant K0, 0 can be written into DX, DY, DM, DS, T, C, and D.

**4-5-10. Swap the high and low byte [SWAP]**

1. Summary

Swap the high and low byte

| High and low byte swap [SWAP] |                 |                      |                     |
|-------------------------------|-----------------|----------------------|---------------------|
| 16 bits                       | SWAP            | 32 bits              | -                   |
| Execution condition           | Normally ON/OFF | Suitable Models      | XC1.XC2.XC3.XC5.XCM |
| Hardware requirement          | -               | Software requirement | -                   |

2. Operands

| Operands | Function                        | Data Type    |
|----------|---------------------------------|--------------|
| S        | The address of the soft element | 16 bits: BIN |

3. Suitable soft components

| Word | Operands | System |    |    |    |    |    |    |    | Constant | Module |    |    |
|------|----------|--------|----|----|----|----|----|----|----|----------|--------|----|----|
|      |          | D      | FD | ED | TD | CD | DX | DY | DM | DS       | K/H    | ID | QD |
|      | S        | •      |    |    | •  | •  |    |    |    |          |        |    |    |

**Description**

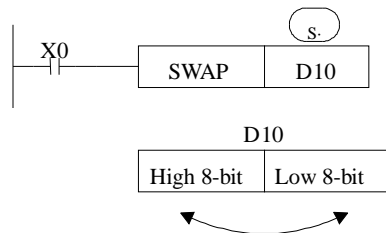

- Low 8 bits and high 8 bits change when it is 16 bits instruction.
- If the instruction is a consecutive executing instruction, each operation cycle should change.



## 4-5-12. Floating move [EMOV]

### 1. Summary

Send the floating number from one soft element to another

| Floating move [EMOV] |                               |                 |                     |
|----------------------|-------------------------------|-----------------|---------------------|
| 16 bits              | -                             | 32 bits         | EMOV                |
| Execution condition  | Normally on/off, edge trigger | Suitable models | XC2、XC3、XC5、XCM、XCC |
| Hardware             | V3.3 and higher               | Software        | V3.3 and higher     |

### 2. Operands

| Operand | Function                         | Type         |
|---------|----------------------------------|--------------|
| S       | Source soft element address      | 32 bits, BIN |
| D       | Destination soft element address | 32 bits, BIN |

### 3. Suitable soft element

| Word | Operand | System |    |    |    |    |    |    |    | Constant | Module |    |    |
|------|---------|--------|----|----|----|----|----|----|----|----------|--------|----|----|
|      |         | D      | FD | ED | TD | CD | DX | DY | DM | DS       | K/H    | ID | QD |
|      | S       | •      | •  |    |    |    | •  | •  | •  | •        | •      |    |    |
|      | D       | •      |    |    |    |    |    | •  | •  | •        |        |    |    |

### Description

<32 bits instruction>

Binary floating → binary floating

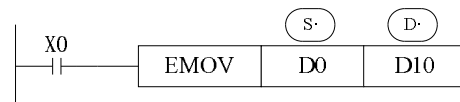

(D1,D0) → (D11,D10)

- X0 is ON, send the floating number from (D1, D0) to (D11, D10).
- X0 is OFF, the instruction doesn't work

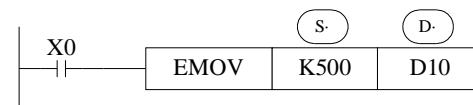

(K500) → (D11,D10)

- If constant value K, H is source soft element, they will be converted to floating number.
- K500 will be converted to floating value.

## 4-6. Data Operation Instructions

| Mnemonic | Function           | Chapter |
|----------|--------------------|---------|
| ADD      | Addition           | 4-6-1   |
| SUB      | Subtraction        | 4-6-2   |
| MUL      | Multiplication     | 4-6-3   |
| DIV      | Division           | 4-6-4   |
| INC      | Increment          | 4-6-5   |
| DEC      | Decrement          | 4-6-5   |
| MEAN     | Mean               | 4-6-6   |
| WAND     | Logic Word And     | 4-6-7   |
| WOR      | Logic Word Or      | 4-6-7   |
| WXOR     | Logic Exclusive Or | 4-6-7   |
| CML      | Compliment         | 4-6-8   |
| NEG      | Negation           | 4-6-9   |

### 4-6-1 Addition [ADD]

#### 1. Summary

Add two numbers and store the result

| Add [ADD]            |                 |                      |                     |
|----------------------|-----------------|----------------------|---------------------|
| 16 bits              | ADD             | 32 bits              | DADD                |
| Execution condition  | Normally ON/OFF | Suitable Models      | XC1.XC2.XC3.XC5.XCM |
| Hardware requirement | -               | Software requirement | -                   |

#### 2. Operands

| Operands | Function           | Data Type          |
|----------|--------------------|--------------------|
| S1       | The number address | 16 bit/32 bit, BIN |
| S2       | The number address | 16 bit/32bit, BIN  |
| D        | The result address | 16 bit/32bit, BIN  |

#### 3. Suitable soft components

| Word | Operands | System |    |    |    |    |    |    |    | Constant | Module |    |    |
|------|----------|--------|----|----|----|----|----|----|----|----------|--------|----|----|
|      |          | D      | FD | ED | TD | CD | DX | DY | DM | DS       | K/H    | ID | QD |
| S1   |          | •      | •  |    | •  | •  | •  | •  | •  | •        | •      |    |    |
| S2   |          | •      | •  |    | •  | •  | •  | •  | •  | •        | •      |    |    |
| D    |          | •      |    |    | •  | •  |    | •  | •  | •        |        |    |    |

**Description**



$$(D10) + (D12) \rightarrow (D14)$$

- The data contained within the two source devices are combined and the total is stored in the specified destination device. Each data's highest bit is the sign bit, 0 stands for positive, 1 stands for negative. All calculations are algebraic processed. (5+ (-8) = -3)
- If the result of a calculation is "0", the "0" flag acts. If the result exceeds 323, 767 (16 bits limit) or 2,147,483,647 (32 bits limit), the carry flag acts. (refer to the next page). If the result exceeds -323,768(16 bits limit) or -2,147,483,648(32 bits limit), the borrow flag acts (Refer to the next page)
- When carry on 32 bits operation, word device's low 16 bits are assigned, the device following closely the preceding device's ID will be the high bits. To avoid ID repetition, we recommend you assign device's ID to be even ID.
- The same device may be used as a source and a destination. If this is the case then the result changes after every scan cycle. Please note this point

**Related flag**

Flag meaning

| Flag  | Name   | Function   |
|-------|--------|--|
| M8020 | Zero   | ON: the calculate result is zero<br>OFF: the calculate result is not zero  |
| M8021 | Borrow | ON: the calculate result is less than -32768(16 bit) or -2147483648(32bit)<br>OFF: the calculate result is over -32768(16 bit) or -2147483648(32bit) |
| M8022 | Carry  | ON: the calculate result is over 32768(16 bit) or 2147483648(32bit)<br>OFF: the calculate result is less than 32768(16 bit) or 2147483648(32bit)     |

**4-6-2. Subtraction [SUB]**

1. Summary

Sub two numbers, store the result

| Subtraction [SUB]    |                 |                      |                     |
|----------------------|-----------------|----------------------|---------------------|
| 16 bits              | SUB             | 32 bits              | DSUB                |
| Execution condition  | Normally ON/OFF | Suitable Models      | XC1.XC2.XC3.XC5.XCM |
| Hardware requirement | -               | Software requirement | -                   |

## 2. Operands

| Operands | Function           | Data Type             |
|----------|--------------------|-----------------------|
| S1       | The number address | 16 bits /32 bits, BIN |
| S2       | The number address | 16 bits /32 bits, BIN |
| D        | The result address | 16 bits /32 bits, BIN |

## 3. Suitable soft component

| Word | Operands | System |    |    |    |    |    |    |    | Constant | Module |    |    |
|------|----------|--------|----|----|----|----|----|----|----|----------|--------|----|----|
|      |          | D      | FD | ED | TD | CD | DX | DY | DM | DS       | K/H    | ID | QD |
| S1   |          | •      | •  |    | •  | •  | •  | •  | •  | •        | •      |    |    |
| S2   |          | •      | •  |    | •  | •  | •  | •  | •  | •        | •      |    |    |
| D    |          | •      |    |    | •  | •  |    | •  | •  | •        |        |    |    |

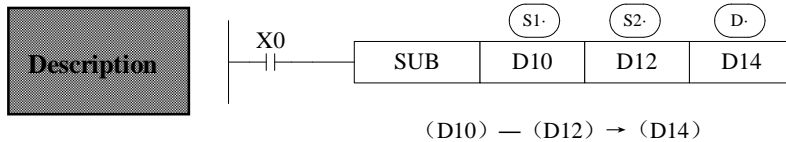

$$(D10) - (D12) \rightarrow (D14)$$

- (S1) Appoint the soft unit's content; subtract the soft unit's content appointed by (S2) in the format of algebra. The result will be stored in the soft unit appointed by (D).  
(5-(-8)=13)
- The action of each flag, the appointment method of 32 bits operation's soft units are both the same with the preceding ADD instruction.
- The importance is: in the preceding program, if X0 is ON, SUB operation will be executed every scan cycle

The relationship of the flag's action and vale's positive/negative is shown below:

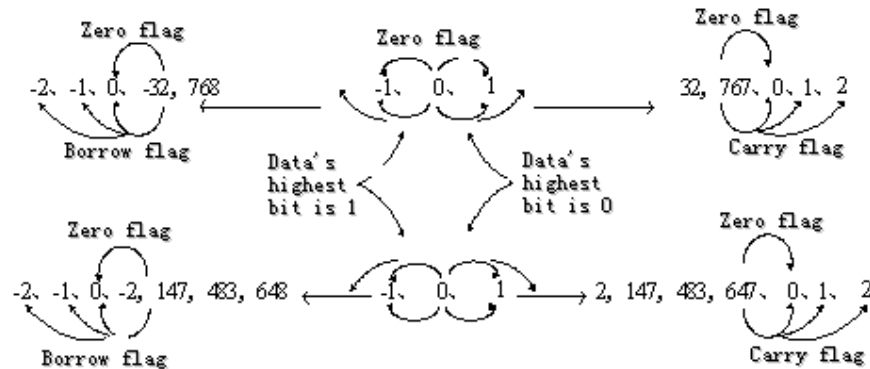

### 4-6-3. Multiplication [MUL]

#### 1. Summary

Multiply two numbers, store the result

| Multiplication [MUL] |                 |                      |                     |
|----------------------|-----------------|----------------------|---------------------|
| 16 bits              | MUL             | 32 bits              | DMUL                |
| Execution condition  | Normally ON/OFF | Suitable Models      | XC1.XC2.XC3.XC5.XCM |
| Hardware requirement | -               | Software requirement | -                   |

#### 2. Operands

| Operands | Function           | Data Type          |
|----------|--------------------|--------------------|
| S1       | The number address | 16 bits/32bits,BIN |
| S2       | The number address | 16 bits/32bits,BIN |
| D        | The result address | 16 bits/32bits,BIN |

#### 3. Suitable soft component

| Word | Operands | System |    |    |    |    |    |    |    | Constant | Module |    |    |
|------|----------|--------|----|----|----|----|----|----|----|----------|--------|----|----|
|      |          | D      | FD | ED | TD | CD | DX | DY | DM | DS       | K/H    | ID | QD |
|      | S1       | •      | •  |    | •  | •  | •  | •  | •  | •        | •      |    |    |
|      | S2       | •      | •  |    | •  | •  | •  | •  | •  | •        | •      |    |    |
|      | D        | •      |    |    | •  | •  |    | •  | •  | •        |        |    |    |

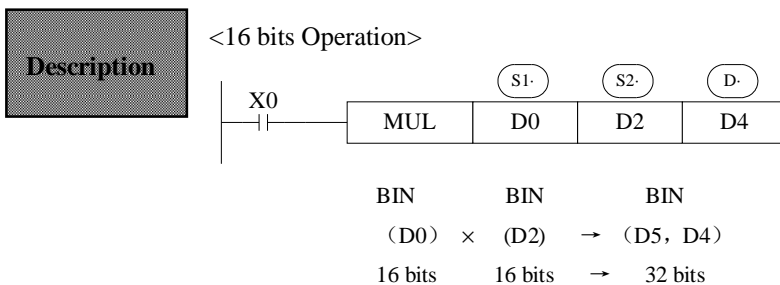

- The contents of the two source devices are multiplied together and the result is stored at the destination device in the format of 32 bits. As in the upward chart: when (D0)=8, (D2)=9, (D5, D4) =72.
- The result's highest bit is the symbol bit: positive (0), negative (1).
- When the bit unit, it can carry on the bit appointment of K1~K8. When appoint K4, only the result's low 16 bits can be obtained.

<32 bits Operation >

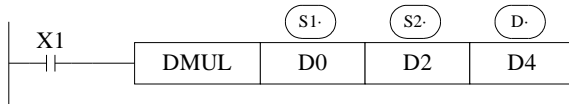

$$\begin{array}{ccc}
 \text{BIN} & \text{BIN} & \text{BIN} \\
 (D1, D0) \times (D3, D2) \rightarrow (D7, D6, D5, D4) \\
 32 \text{ bits} & 32 \text{ bits} \rightarrow & 64 \text{ bits}
 \end{array}$$

- When use 2 bits Operation, the result is stored at the destination device in the format of 64 bits.
- Even use word device, 64 bits results can't be monitored at once.

**4-6-4. Division [DIV]**

1. Summary

Divide two numbers and store the result

| Division [DIV]       |                                      |                      |                     |
|----------------------|--------------------------------------|----------------------|---------------------|
| 16 bits              | DIV                                  | 32 bits              | DDIV                |
| Execution condition  | Normally ON/OFF, rising/falling edge | Suitable Models      | XC1.XC2.XC3.XC5.XCM |
| Hardware requirement | -                                    | Software requirement | -                   |

2. Operands

| Operands | Function           | Data Type              |
|----------|--------------------|------------------------|
| S1       | The number address | 16 bits / 32 bits, BIN |
| S2       | The number address | 16 bits /32 bits, BIN  |
| D        | The result address | 16 bits /32 bits, BIN  |

3. Suitable soft components

| Word | Operands | System |    |    |    |    |    |    |    | Constant | Module |    |    |
|------|----------|--------|----|----|----|----|----|----|----|----------|--------|----|----|
|      |          | D      | FD | ED | TD | CD | DX | DY | DM | DS       | K/H    | ID | QD |
|      | S1       | •      | •  |    | •  | •  | •  | •  | •  | •        | •      |    |    |
|      | S2       | •      | •  |    | •  | •  | •  | •  | •  | •        | •      |    |    |
|      | D        | •      |    |    | •  | •  |    | •  | •  | •        |        |    |    |

**Description**

**<16 bits operation >**

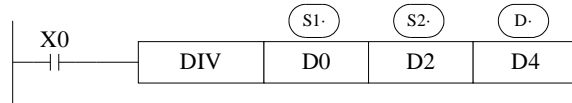

| Dividend | Divisor | Result  | Remainder |
|----------|---------|---------|-----------|
| BIN      | BIN     | BIN     | BIN       |
| (D0) ÷   | (D2) →  | D4) --- | (D5)      |
| 16 bits  | 16 bits | 16 bits | 16 bits   |

- (S1) Appoints the device's content be the dividend, (S2) appoints the device's content be the divisor, (D) and appoints the device and the next one to store the result and the remainder.
- In the above example, if input X0 is ON, division operation is executed every scan cycle.

**<32 bits operation >**

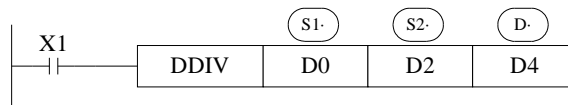

| Dividend   | Divisor  | Result       | Remainder |
|------------|----------|--------------|-----------|
| BIN        | BIN      | BIN          | BIN       |
| (D1, D0) ÷ | (D3, D2) | (D5, D4) --- | (D7, D6)  |
| 32 bits    | 32 bits  | 32 bits      | 32 bits   |

- The dividend is composed by the device appointed by (S1) and the next one. The divisor is composed by the device appointed by (S2) and the next one. The result and the remainder are stored in the four sequential devices, the first one is appointed by (D).
- If the value of the divisor is 0, then an operation error is executed and the operation of the DIV instruction is cancelled
- The highest bit of the result and remainder is the symbol bit (positive: 0, negative: 1). When any of the dividend or the divisor is negative, then the result will be negative. When the dividend is negative, then the remainder will be negative.

## 4-6-5. Increment [INC] & Decrement [DEC]

### 1. Summary

Increase or decrease the number

| Increment 1[INC]     |                                      |                      |                     |
|----------------------|--------------------------------------|----------------------|---------------------|
| 16 bits              | INC                                  | 32 bits              | DINC                |
| Execution condition  | Normally ON/OFF, rising/falling edge | Suitable Models      | XC1.XC2.XC3.XC5.XCM |
| Hardware requirement | -                                    | Software requirement | -                   |
| Increment 1[DEC]     |                                      |                      |                     |
| 16 bits              | DEC                                  | 32 bits              | DDEC                |
| Execution condition  | Normally ON/OFF, rising/falling edge | Suitable Models      | XC1.XC2.XC3.XC5.XCM |
| Hardware requirement | -                                    | Software requirement | -                   |

### 2. Operands

| Operands | Function           | Data Type             |
|----------|--------------------|-----------------------|
| D        | The number address | 16 bits / 32bits, BIN |

### 3. Suitable soft components

| Word | Operands | System |    |    |    |    |    |    |    | Constant | Module |    |    |
|------|----------|--------|----|----|----|----|----|----|----|----------|--------|----|----|
|      |          | D      | FD | ED | TD | CD | DX | DY | DM | DS       | K/H    | ID | QD |
| D    | •        |        |    |    | •  | •  |    | •  | •  | •        |        |    |    |

#### Description

< Increment [INC]>

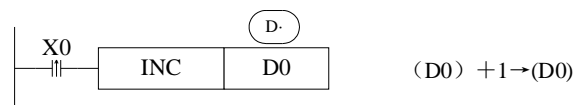

- On every execution of the instruction the device specified as the destination (D) has its current value incremented (increased) by a value of 1.
- In 16 bits operation, when +32,767 is reached, the next increment will write -32,767 to the destination device. In this case, there's no additional flag to identify this change in the counted value.

<Decrement [DEC]>

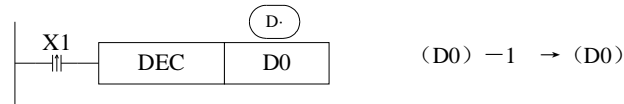

- On every execution of the instruction the device specified as the destination (D) has its current value decremented (decreased) by a value of 1.
- When -32, 768 or -2, 147, 483, 648 is reached, the next decrement will write +32, 767 or +2, 147, 483, 647 to the destination device.

**4-6-6. Mean [MEAN]**

1. Summary

Get the mean value of numbers

| Mean [MEAN]          |                                      |                      |                     |
|----------------------|--------------------------------------|----------------------|---------------------|
| 16 bits              | MEAN                                 | 32 bits              | DMEAN               |
| Execution condition  | Normally ON/OFF, rising/falling edge | Suitable Models      | XC1.XC2.XC3.XC5.XCM |
| Hardware requirement | -                                    | Software requirement | -                   |

2. Operands

| Operands | Function                        | Data Type    |
|----------|---------------------------------|--------------|
| S        | The head address of the numbers | 16 bits, BIN |
| D        | The mean result address         | 16 bits, BIN |
| n        | The number quantity             | 16 bits, BIN |

3. Suitable soft components

| Word | Operands | System |    |    |    |    |    |    |    | Constant | Module |    |    |
|------|----------|--------|----|----|----|----|----|----|----|----------|--------|----|----|
|      |          | D      | FD | ED | TD | CD | DX | DY | DM | DS       | K/H    | ID | QD |
|      | S        | •      | •  |    | •  | •  |    | •  | •  | •        |        |    |    |
|      | D        | •      |    |    | •  | •  |    | •  | •  | •        |        |    |    |
|      | n        |        |    |    |    |    |    |    |    |          | •      |    |    |

**Description**

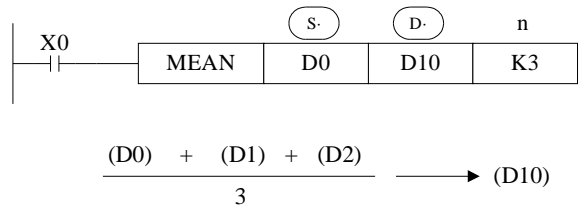

- The value of all the devices within the source range is summed and then divided by the number of devices summed, i.e. n... This generates an integer mean value which is stored in the destination device (D) The remainder of the calculated mean is ignored.
- If the value of n is specified outside the stated range (1 to 64) an error is generated.

**4-6-7. Logic AND [WAND], Logic OR [WOR], Logic Exclusive OR [WXOR]**

1. Summary

Do logic AND, OR, XOR for numbers

|                           |                                      |                      |                     |
|---------------------------|--------------------------------------|----------------------|---------------------|
| Logic AND [WAND]          |                                      |                      |                     |
| 16 bits                   | WAND                                 | 32 bits              | DWAND               |
| Execution condition       | Normally ON/OFF, rising/falling edge | Suitable Models      | XC1.XC2.XC3.XC5.XCM |
| Hardware requirement      | -                                    | Software requirement | -                   |
| Logic OR [WOR]            |                                      |                      |                     |
| 16 bits                   | WOR                                  | 32 bits              | DWOR                |
| Execution condition       | Normally ON/OFF, rising/falling edge | Suitable Models      | XC1.XC2.XC3.XC5.XCM |
| Hardware requirement      | -                                    | Software requirement | -                   |
| Logic Exclusive OR [WXOR] |                                      |                      |                     |
| 16 bits                   | WXOR                                 | 32 bits              | DWXOR               |
| Execution condition       | Normally ON/OFF, rising/falling edge | Suitable Models      | XC1.XC2.XC3.XC5.XCM |
| Hardware requirement      | -                                    | Software requirement | -                   |

## 2. Operands

| Operands | Function                 | Data Type       |
|----------|--------------------------|-----------------|
| S1       | The soft element address | 16bit/32bit,BIN |
| S2       | The soft element address | 16bit/32bit,BIN |
| D        | The result address       | 16bit/32bit,BIN |

## 3. Suitable soft components

| Word | Operands | System |    |    |    |    |    |    |    | Constant | Module |    |    |
|------|----------|--------|----|----|----|----|----|----|----|----------|--------|----|----|
|      |          | D      | FD | ED | TD | CD | DX | DY | DM | DS       | K/H    | ID | QD |
| S1   |          | •      | •  |    | •  | •  | •  | •  | •  | •        |        |    |    |
| S2   |          | •      | •  |    | •  | •  | •  | •  | •  | •        |        |    |    |
| D    |          | •      |    |    | •  | •  |    | •  | •  | •        |        |    |    |

### Description

- < Execute logic AND operation with each bit >

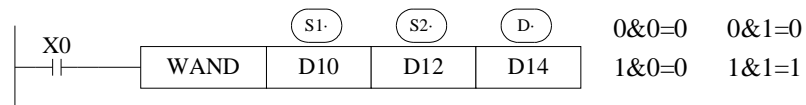

- < Execute logic OR operation with each bit >

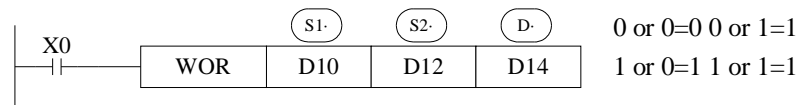

- < Execute logic Exclusive OR operation with each bit >

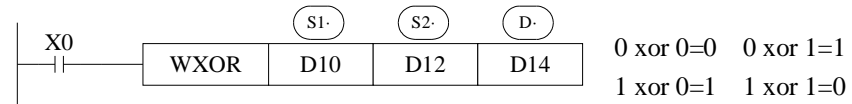

If use this instruction along with CML instruction, XOR NOT operation could also be executed.

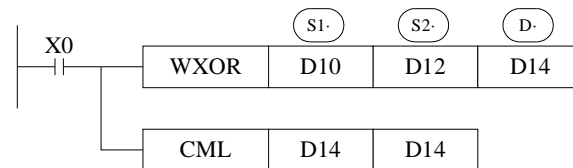

## 4-6-8. Converse [CML]

### 1. Summary

Converse the phase of the numbers

| Converse [CML]       |                              |                         |                        |
|----------------------|------------------------------|-------------------------|------------------------|
| 16 bits              | CML                          |                         | 32 bits DCML           |
| Execution condition  | Normally rising/falling edge | ON/OFF, Suitable Models | XC1.XC2.XC3.XC5.XCM    |
| Hardware requirement | -                            |                         | Software requirement - |

### 2. Operands

| Operands | Function              | Data Type            |
|----------|-----------------------|----------------------|
| S        | Source number address | 16 bits/32 bits, BIN |
| D        | Result address        | 16 bits/32 bits, BIN |

### 3. Suitable soft components

| Word | Operands | System |    |    |    |    |    |    |    | Constant | Module |    |    |
|------|----------|--------|----|----|----|----|----|----|----|----------|--------|----|----|
|      |          | D      | FD | ED | TD | CD | DX | DY | DM | DS       | K/H    | ID | QD |
| S1   |          | •      | •  |    | •  | •  | •  | •  | •  | •        | •      |    |    |
| D    |          | •      |    |    | •  | •  |    | •  | •  | •        |        |    |    |

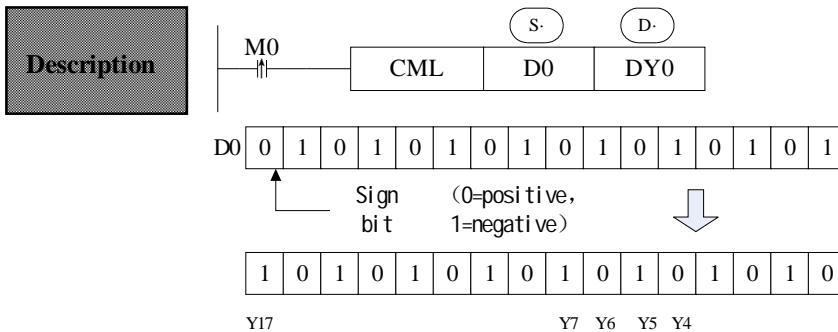

- Each data bit in the source device is inverted (1→0, 0→1) and sent to the destination device. If use constant K in the source device, it can be auto convert to be binary.
- It's available when you want to inverted output the PLC's output

< Reading of inverted input >

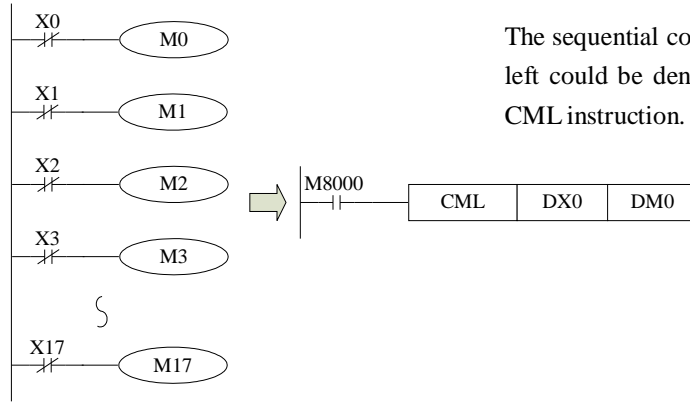

The sequential control instruction in the left could be denoted by the following CML instruction.

**4-6-9. Negative [NEG]**

1. Summary

Get the negative number

| Negative [NEG]       |                                      |                      |                     |
|----------------------|--------------------------------------|----------------------|---------------------|
| 16 bits              | NEG                                  | 32 bits              | DNEG                |
| Execution condition  | Normally ON/OFF, rising/falling edge | Suitable Models      | XC1.XC2.XC3.XC5.XCM |
| Hardware requirement | -                                    | Software requirement | -                   |

2. Operands

| Operands | Function                  | Data Type          |
|----------|---------------------------|--------------------|
| D        | The source number address | 16 bits/ bits, BIN |

3. Suitable soft components

| Word | Operands | System |    |    |    |    |    |    |    | Constant | Module |    |    |
|------|----------|--------|----|----|----|----|----|----|----|----------|--------|----|----|
|      |          | D      | FD | ED | TD | CD | DX | DY | DM | DS       | K/H    | ID | QD |
| D    |          | •      |    |    | •  | •  |    | •  | •  | •        |        |    |    |

**Description**

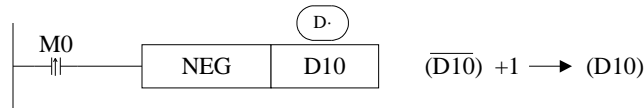

- The bit format of the selected device is inverted, I.e. any occurrence of a “1” becomes a “0” and any occurrence of “0” becomes “1”, when this is complete, a further binary 1 is added to the bit format. The result is the total logic sign change of the selected devices contents.

**4-7. Shift Instructions**

| Mnemonic | Function               | Chapter |
|----------|------------------------|---------|
| SHL      | Arithmetic shift left  | 4-7-1   |
| SHR      | Arithmetic shift right | 4-7-1   |
| LSL      | Logic shift left       | 4-7-2   |
| LSR      | Logic shift right      | 4-7-2   |
| ROL      | Rotation left          | 4-7-3   |
| ROR      | Rotation right         | 4-7-3   |
| SFTL     | Bit shift left         | 4-7-4   |
| SFTR     | Bit shift right        | 4-7-5   |
| WSFL     | Word shift left        | 4-7-6   |
| WSFR     | Word shift right       | 4-7-7   |

**4-7-1. Arithmetic shift left [SHL], Arithmetic shift right [SHR]**

1. Summary

Do arithmetic shift left/right for the numbers

| Arithmetic shift left [SHL]  |                                      |                      |                 |
|------------------------------|--------------------------------------|----------------------|-----------------|
| 16 bits                      | SHL                                  | 32 bits              | DSHL            |
| Execution condition          | Normally ON/OFF, rising/falling edge | Suitable Models      | XC2.XC3.XC5.XCM |
| Hardware requirement         | -                                    | Software requirement | -               |
| Arithmetic shift right [SHR] |                                      |                      |                 |
| 16 bits                      | SHR                                  | 32 bits              | DSHR            |
| Execution condition          | Normally ON/OFF, rising/falling edge | Suitable Models      | XC2.XC3.XC5.XCM |
| Hardware requirement         | -                                    | Software requirement | -               |

## 2. Operands

| Operands | Function                  | Data Type       |
|----------|---------------------------|-----------------|
| D        | The source data address   | 16bit/32bit,BIN |
| n        | Shift left or right times | 16bit/32bit,BIN |

## 3. Suitable soft components

| Word | Operands | System |    |    |    |    |    |    |    | Constant | Module |    |    |
|------|----------|--------|----|----|----|----|----|----|----|----------|--------|----|----|
|      |          | D      | FD | ED | TD | CD | DX | DY | DM | DS       | K/H    | ID | QD |
| D    | •        |        |    |    | •  | •  |    | •  | •  | •        |        |    |    |
| n    |          |        |    |    |    |    |    |    |    |          | •      |    |    |

### Description

- After once execution, the low bit is filled in 0, the final bit is stored in carry flag.
- After once execution, the high bit is same with the bit before shifting; the final bit is stored in carry flag.

< Arithmetic shift left >

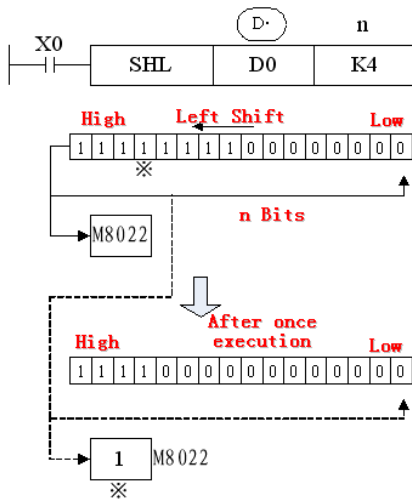

< Arithmetic shift right >

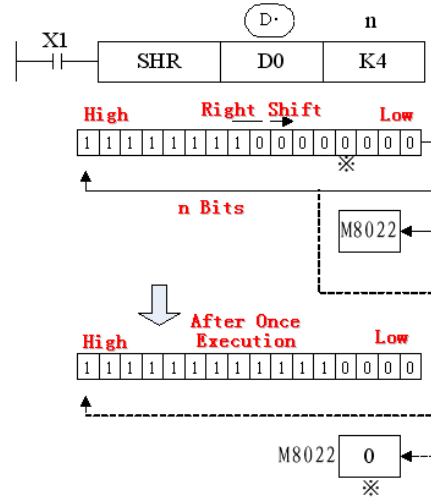

## 4-7-2. Logic shift left [LSL], Logic shift right [LSR]

### 1. Summary

Do logic shift right/left for the numbers

| Logic shift left [LSL]  |                                      |                      |                 |
|-------------------------|--------------------------------------|----------------------|-----------------|
| 16 bits                 | LSL                                  | 32 bits              | DLSL            |
| Execution condition     | Normally ON/OFF, rising/falling edge | Suitable Models      | XC2.XC3.XC5.XCM |
| Hardware requirement    | -                                    | Software requirement | -               |
| Logic shift right [LSR] |                                      |                      |                 |
| 16 bits                 | LSR                                  | 32 bits              | DLSR            |
| Execution condition     | Normally ON/OFF, rising/falling edge | Suitable Models      | XC2.XC3.XC5.XCM |
| Hardware requirement    | -                                    | Software requirement | -               |

### 2. Operands

| Operands | Function                          | Data Type            |
|----------|-----------------------------------|----------------------|
| D        | Source data address               | 16 bits/32 bits, BIN |
| n        | Arithmetic shift left/right times | 16 bits/32bits, BIN  |

### 3. Suitable soft components

| Word | Operands | System |    |    |    |    |    |    |    | Constant | Module |    |    |
|------|----------|--------|----|----|----|----|----|----|----|----------|--------|----|----|
|      |          | D      | FD | ED | TD | CD | DX | DY | DM | DS       | K/H    | ID | QD |
| D    |          | •      |    |    | •  | •  |    | •  | •  | •        |        |    |    |
| n    |          |        |    |    |    |    |    |    |    |          | •      |    |    |

**Description**

- After once execution, the low bit is filled in 0, the final bit is stored in carry flag.
  - LSL meaning and operation are the same as SHL.
  - After once execution, the high bit is same with the bit before shifting, the final bit is stored in carry flag.
- LSR and SHR are different, LSR add 0 in high bit when moving, and SHR all bits are moved.

< Logic shift left >

< Logic shift right >

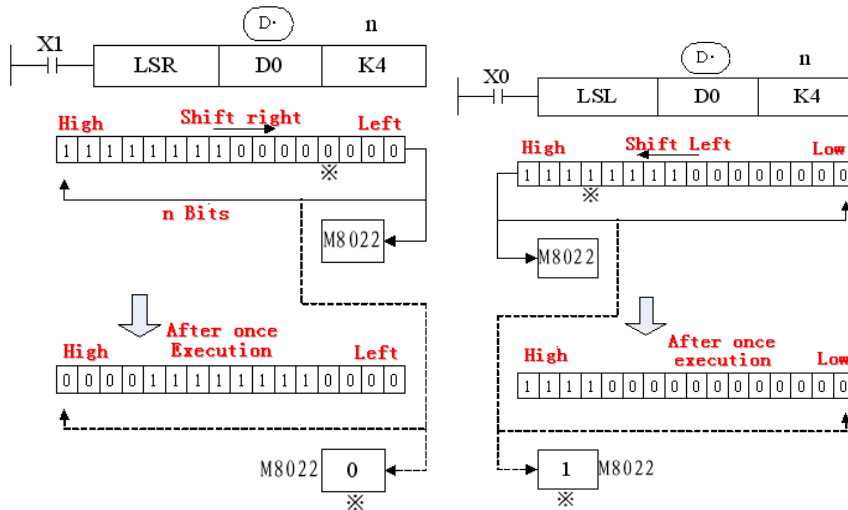

**4-7-3. Rotation shift left [ROL], Rotation shift right [ROR]**

1. Summary

Continue and cycle shift left or right

| Rotation shift left [ROL]  |                                      |                      |                 |
|----------------------------|--------------------------------------|----------------------|-----------------|
| 16 bits                    | ROL                                  | 32 bits              | DROL            |
| Execution condition        | Normally ON/OFF, rising/falling edge | Suitable Models      | XC2.XC3.XC5.XCM |
| Hardware requirement       | -                                    | Software requirement | -               |
| Rotation shift right [ROR] |                                      |                      |                 |
| 16 bits                    | ROR                                  | 32 bits              | DROR            |
| Execution condition        | Normally ON/OFF, rising/falling edge | Suitable Models      | XC2.XC3.XC5.XCM |
| Hardware requirement       | -                                    | Software requirement | -               |

## 2. Operands

| Operands | Function                  | Data Type            |
|----------|---------------------------|----------------------|
| D        | Source data address       | 16 bits/32 bits, BIN |
| n        | Shift right or left times | 16 bits/32 bits, BIN |

## 3. Suitable soft components

| Word | Operands | System |    |    |    |    |    |    |    | Constant | Module |    |    |
|------|----------|--------|----|----|----|----|----|----|----|----------|--------|----|----|
|      |          | D      | FD | ED | TD | CD | DX | DY | DM | DS       | K/H    | ID | QD |
| D    | •        |        |    |    | •  | •  |    | •  | •  | •        |        |    |    |
| n    |          |        |    |    |    |    |    |    |    |          | •      |    |    |

### Description

- The bit format of the destination device is rotated n bit places to the left on every operation of the instruction.

#### < Rotation shift left >

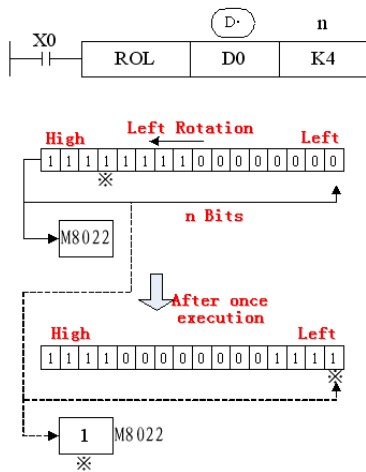

#### < Rotation shift right >

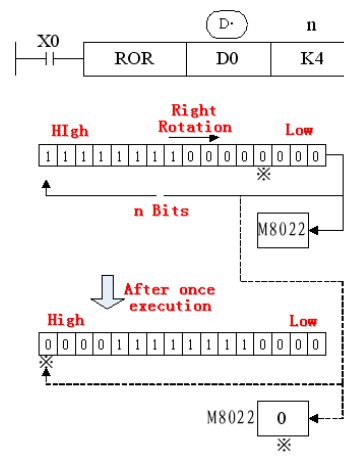

## 4-7-4. Bit shift left [SFTL]

### 1. Summary

#### Bit shift left

| Bit shift left [SFTL] |                                      |                      |                 |
|-----------------------|--------------------------------------|----------------------|-----------------|
| 16 bits               | SFTL                                 | 32 bits              | DSFTL           |
| Execution condition   | Normally ON/OFF, rising/falling edge | Suitable Models      | XC2.XC3.XC5.XCM |
| Hardware requirement  | -                                    | Software requirement | -               |

## 2. Operands

| Operands | Function                         | Types                 |
|----------|----------------------------------|-----------------------|
| S        | Source soft element head address | bit                   |
| D        | Target soft element head address | bit                   |
| n1       | Source data quantity             | 16 bits /32 bits, BIN |
| n2       | Shift left times                 | 16 bits/32 bits, BIN  |

## 3. Suitable soft components

| Word | Operands | System |    |    |    |    |    |    |    | Constant | Module |    |    |
|------|----------|--------|----|----|----|----|----|----|----|----------|--------|----|----|
|      |          | D      | FD | ED | TD | CD | DX | DY | DM | DS       | K/H    | ID | QD |
|      | n1       | •      |    |    | •  | •  | •  | •  | •  | •        | •      |    |    |
|      | n2       | •      |    |    | •  | •  | •  | •  | •  | •        | •      |    |    |

| Bit | Operands | System |   |   |   |   |   |      |
|-----|----------|--------|---|---|---|---|---|------|
|     |          | X      | Y | M | S | T | C | Dn.m |
|     | S        | •      | • | • | • | • | • |      |
|     | D        |        | • | • | • | • | • |      |

### Description

- The instruction copies n2 source devices to a bit stack of length n1. For every new addition of n2 bits, the existing data within the bit stack is shifted n2 bits to the left/right. Any bit data moving to the position exceeding the n1 limit is diverted to an overflow area.
- In every scan cycle, loop shift left action will be executed



- ① M15~M12→Overflow
- ② M11~M8→M15~M12
- ③ M7~M4→M11~M8
- ④ M3~M0→M7~M4
- ⑤ X3~X0→M3~M0

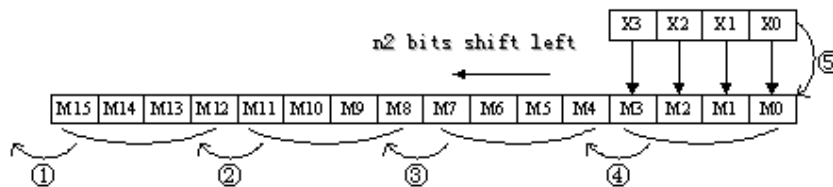

## 4-7-5. Bit shift right [SFTR]

### 1. Summary

Bit shift right

| Bit shift right [SFTR] |                     |                      |                 |
|------------------------|---------------------|----------------------|-----------------|
| 16 bits                | SFTR                | 32 bits              | DSFTR           |
| Execution condition    | rising/falling edge | Suitable Models      | XC2.XC3.XC5.XCM |
| Hardware requirement   | -                   | Software requirement | -               |

### 2. Operands

| Operands | Function                         | Data Type            |
|----------|----------------------------------|----------------------|
| S        | Source soft element head address | bit                  |
| D        | Target soft element head address | bit                  |
| n1       | Source data quantity             | 16 bits/32 bits, BIN |
| n2       | Shift right times                | 16 bits/32 bits, BIN |

### 3. Suitable soft components

|      |          |        |    |    |    |    |    |      |    |          |        |    |    |
|------|----------|--------|----|----|----|----|----|------|----|----------|--------|----|----|
| Word | Operands | System |    |    |    |    |    |      |    | Constant | Module |    |    |
|      |          | D      | FD | ED | TD | CD | DX | DY   | DM | DS       | K/H    | ID | QD |
|      | n1       | •      |    |    | •  | •  | •  | •    | •  | •        | •      |    |    |
|      | n2       | •      |    |    | •  | •  | •  | •    | •  | •        | •      |    |    |
| Bit  | Operands | System |    |    |    |    |    |      |    |          |        |    |    |
|      |          | X      | Y  | M  | S  | T  | C  | Dn,m |    |          |        |    |    |
|      | S        | •      | •  | •  | •  | •  | •  |      |    |          |        |    |    |
|      | D        |        | •  | •  | •  | •  | •  |      |    |          |        |    |    |

**Description**

- The instruction copies n2 source devices to a bit stack of length n1. For every new addition of n2 bits, the existing data within the bit stack is shifted n2 bits to the left/right. Any bit data moving to the position exceeding the n1 limit is diverted to an overflow area.
- In every scan cycle, loop shift right action will be executed

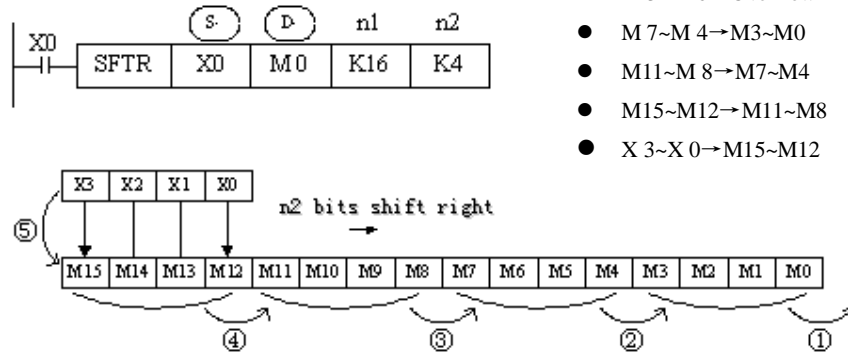

- M 3~M 0→Overflow
- M 7~M 4→M3~M0
- M11~M 8→M7~M4
- M15~M12→M11~M8
- X 3~X 0→M15~M12

**4-7-6. Word shift left [WSFL]**

1. Summary

Word shift left

| Word shift left [ [WSFL] |                     |                      |                 |
|--------------------------|---------------------|----------------------|-----------------|
| 16 bits                  | WSFL                | 32 bits              | -               |
| Execution condition      | rising/falling edge | Suitable Models      | XC2.XC3.XC5.XCM |
| Hardware requirement     | -                   | Software requirement | -               |

2. Operands

| Operands | Function                         | Data Type             |
|----------|----------------------------------|-----------------------|
| S        | Source soft element head address | 16 bits/32 bits, BIN  |
| D        | Target soft element head address | 16 bits /32 bits, BIN |
| n1       | Source data quantity             | 16 bits /32 bits, BIN |
| n2       | Word shift left times            | 16 bits /32 bits, BIN |

### 3. Suitable soft components

| Word | Operands | System |    |    |    |    |    |    |    | Constant | Module |    |    |
|------|----------|--------|----|----|----|----|----|----|----|----------|--------|----|----|
|      |          | D      | FD | ED | TD | CD | DX | DY | DM | DS       | K/H    | ID | QD |
| S    |          | •      | •  |    | •  | •  | •  | •  | •  | •        |        |    |    |
| D    |          | •      |    |    | •  | •  |    | •  | •  | •        |        |    |    |
| n1   |          | •      |    |    | •  | •  |    | •  | •  | •        | •      |    |    |
| n2   |          | •      |    |    | •  | •  |    | •  | •  | •        | •      |    |    |

#### Description

- The instruction copies n2 source devices to a word stack of length n1. For each addition of n2 words, the existing data within the word stack is shifted n2 words to the left. Any word data moving to a position exceeding the n1 limit is diverted to an overflow area.
- In every scan cycle, loop shift left action will be executed.

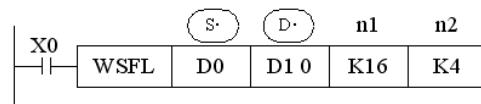

- ① D25~D22→Overflow
- ② D21~D18→D25~D22
- ③ D17~D14→D21~D18
- ④ D13~D10→D17~D14
- ⑤ D3~D0→D13~D10

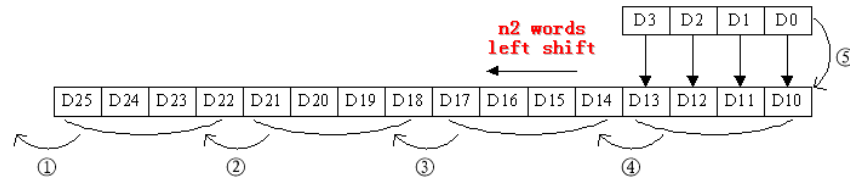

### 4-7-7. Word shift right [WSFR]

#### 1. Summary

Word shift right

| Word shift right [WSFR] |                     |                      |                 |
|-------------------------|---------------------|----------------------|-----------------|
| 16 bits                 | WSFR                | 32 bits              | -               |
| Execution condition     | rising/falling edge | Suitable Models      | XC2.XC3.XC5.XCM |
| Hardware requirement    | -                   | Software requirement | -               |

## 2. Operands

| Operands | Function                         | Data Type            |
|----------|----------------------------------|----------------------|
| S        | Source soft element head address | 16 bits/32 bits, BIN |
| D        | Target soft element head address | 16 bits/32 bits, BIN |
| n1       | Source data quantity             | 16 bits/32 bits, BIN |
| n2       | Shift right times                | 16 bits/32 bits, BIN |

## 3. Suitable soft components

| Word | Operands | System |    |    |    |    |    |    |    | Constant | Module |    |    |
|------|----------|--------|----|----|----|----|----|----|----|----------|--------|----|----|
|      |          | D      | FD | ED | TD | CD | DX | DY | DM | DS       | K/H    | ID | QD |
| S    |          | •      | •  |    | •  | •  | •  | •  | •  | •        |        |    |    |
| D    |          | •      |    |    | •  | •  |    | •  | •  | •        |        |    |    |
| n1   |          | •      |    |    | •  | •  |    | •  | •  | •        | •      |    |    |
| n2   |          | •      |    |    | •  | •  |    | •  | •  | •        | •      |    |    |

### Description

- The instruction copies n2 source devices to a word stack of length n1. For each addition of n2 words, the existing data within the word stack is
  - In every scan cycle, loop shift right action will be executed

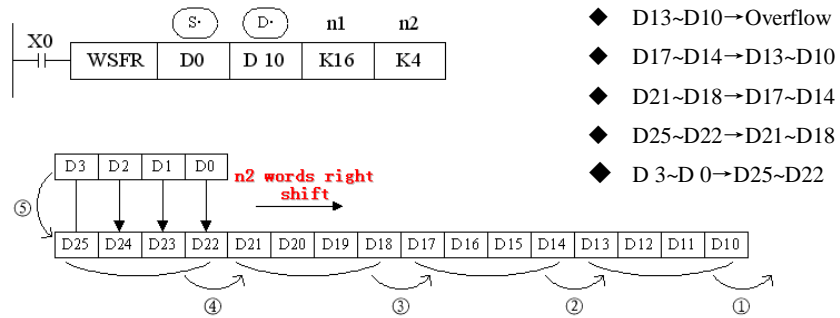

## 4-8. Data Convert

| Mnemonic | Function  | Chapter |
|----------|---|---------|
| WTD      | Single word integer converts to double word integer | 4-8-1   |
| FLT      | 16 bits integer converts to float point             | 4-8-2   |
| DFLT     | 32 bits integer converts to float point             | 4-8-2   |

|       |   |        |
|-------|---|--------|
| FLTD  | 64 bits integer converts to float point | 4-8-2  |
| INT   | Float point converts to integer         | 4-8-3  |
| BIN   | BCD convert to binary                   | 4-8-4  |
| BCD   | Binary converts to BCD                  | 4-8-5  |
| ASCI  | Hex. converts to ASCII                  | 4-8-6  |
| HEX   | ASCII converts to Hex.                  | 4-8-7  |
| DECO  | Coding                                  | 4-8-8  |
| ENCO  | High bit coding                         | 4-8-9  |
| ENCOL | Low bit coding                          | 4-8-10 |

#### 4-8-1. Single word integer converts to double word integer [WTD]

##### 1. Summary

| Single word integer converts to double word integer [WTD] |                                      |                      |                 |
|---|--------------------------------------|----------------------|-----------------|
| 16 bits   | WTD                                  | 32 bits              | -               |
| Execution condition                                       | Normally ON/OFF, rising/falling edge | Suitable Models      | XC2.XC3.XC5.XCM |
| Hardware requirement                                      | -                                    | Software requirement | -               |

##### 2. Operands

| Operands | Function                    | Data Type    |
|----------|-----------------------------|--------------|
| S        | Source soft element address | 16 bits, BIN |
| D        | Target soft element address | 32 bits, BIN |

##### 3. Suitable soft components

| Word | Operands | System |    |    |    |    |    |    |    | Constant | Module |    |
|------|----------|--------|----|----|----|----|----|----|----|----------|--------|----|
|      |          | D      | FD | ED | TD | CD | DX | DY | DM | DS       | K/H    | ID |
|      | S        | •      | •  |    | •  | •  | •  | •  | •  | •        |        |    |
| D    | •        |        |    | •  | •  |    | •  | •  | •  |          |        |    |





**Description**

<16 bits>

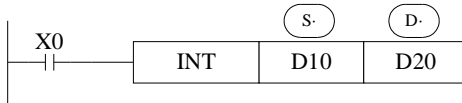

(D11,D10) → (D20)  
 Binary Float      BIN integer  
 Give up the data after the decimal dot

<32 bits>

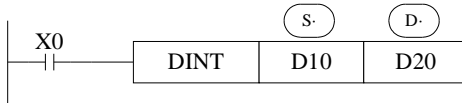

(D11,D10) → (D20,D21)  
 Binary Float      BIN integer  
 Give up the data after the decimal dot

- The binary source number is converted into a BIN integer and stored at the destination device. Abandon the value behind the decimal point.
- This instruction is contrary to FLT instruction.
- When the result is 0, the flag bit is ON  
 When converting, less than 1 and abandon it, zero flag is ON.  
 The result is over below data, the carry flag is ON.  
 16 bits operation: -32,768~32,767  
 32 bits operation: -2,147,483,648~2,147,483,647

**4-8-4. BCD convert to binary [BIN]**

1. Summary

| BCD convert to binary [BIN] |                              |                         |                 |
|-----------------------------|------------------------------|-------------------------|-----------------|
| 16 bits                     | BIN                          | 32 bits                 | -               |
| Execution condition         | Normally rising/falling edge | ON/OFF, Suitable Models | XC2.XC3.XC5.XCM |
| Hardware requirement        | -                            | Software requirement    | -               |

2. Operands

| Operands | Function                    | Data Type            |
|----------|-----------------------------|----------------------|
| S        | Source soft element address | BCD                  |
| D        | Target soft element address | 16 bits/32 bits, BIN |

3. Suitable soft components

| Word | Operands | System |    |    |    |    |    |    |    | Constant | Module |    |    |
|------|----------|--------|----|----|----|----|----|----|----|----------|--------|----|----|
|      |          | D      | FD | ED | TD | CD | DX | DY | DM | DS       | K/H    | ID | QD |
|      | S        | •      | •  |    | •  | •  | •  | •  | •  | •        |        |    |    |
|      | D        | •      |    |    | •  | •  |    | •  | •  | •        |        |    |    |

**Description**

Convert and move instruction of Source (BCD) → destination (BIN)

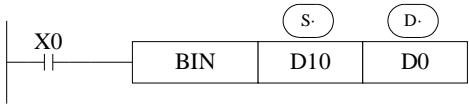

- When source data is not BCD code, M8067 (Operation error) , M8004 (error occurs)
- As constant K automatically converts to binary, so it's not suitable for this instruction.

**4-8-5. Binary convert to BCD [BCD]**

1. Summary

| Binary convert to BCD [BCD] |                                      |                      |                 |
|-----------------------------|--------------------------------------|----------------------|-----------------|
| 16 bits                     | BCD                                  | 32 bits              | -               |
| Execution condition         | Normally ON/OFF, rising/falling edge | Suitable Models      | XC2.XC3.XC5.XCM |
| Hardware requirement        | -                                    | Software requirement | -               |

2. Operands

| Operands | Function                    | Data Type            |
|----------|-----------------------------|----------------------|
| S        | Source soft element address | 16 bits/32 bits, BIN |
| D        | Target soft element address | BCD code             |

3. Suitable soft components

| Word | Operands | System |    |    |    |    |    |    |    | Constant | Module |    |    |
|------|----------|--------|----|----|----|----|----|----|----|----------|--------|----|----|
|      |          | D      | FD | ED | TD | CD | DX | DY | DM | DS       | K/H    | ID | QD |
|      | S        | •      | •  |    | •  | •  | •  | •  | •  | •        |        |    |    |
|      | D        | •      |    |    | •  | •  |    | •  | •  | •        |        |    |    |

**Description**

Convert and move instruction of source (BIN)→destination (BCD)



- This instruction can be used to output data directly to a seven-segment display.

## 4-8-6. Hex. Converts to ASCII [ASCI]

### 1. Summary

| Hex. convert to ASCII [ASCI] |                                      |                      |                 |
|------------------------------|--------------------------------------|----------------------|-----------------|
| 16 bits                      | ASCI                                 | 32 bits              | -               |
| Execution condition          | Normally ON/OFF, rising/falling edge | Suitable Models      | XC2.XC3.XC5.XCM |
| Hardware requirement         | -                                    | Software requirement | -               |

### 2. Operands

| Operands | Function                     | Data Type    |
|----------|------------------------------|--------------|
| S        | Source soft element address  | 2 bits, HEX  |
| D        | Target soft element address  | ASCII code   |
| n        | Transform character quantity | 16 bits, BIN |

### 3. Suitable soft components

| Word | Operands | System |    |    |    |    |    |    |    | Constant | Module |    |    |
|------|----------|--------|----|----|----|----|----|----|----|----------|--------|----|----|
|      |          | D      | FD | ED | TD | CD | DX | DY | DM | DS       | K/H    | ID | QD |
|      | S        | •      | •  |    | •  | •  | •  | •  | •  | •        |        |    |    |
|      | D        | •      |    |    | •  | •  |    | •  | •  | •        |        |    |    |
|      | n        | •      |    |    | •  | •  |    | •  | •  | •        | •      |    |    |

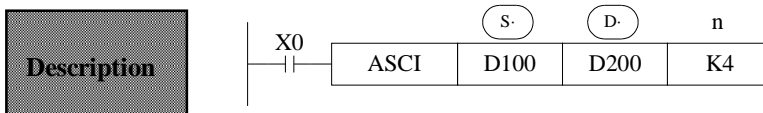

Convert each bit of source's (S) hex format data to be ASCII code, move separately to the high 8 bits and low 8 bits of destination (D). The convert alphanumeric number is assigned with n.

(D) is low 8 bits, high 8 bits, store ASCII data.

The convert result is this

Assign start device:

(D100)=0ABCH

(D101)=1234H

(D102)=5678H

[0]=30H      [1]=31H  
 [5]=35H      [A]=41H  
 [2]=32H      [6]=36H  
 [B]=42H      [3]=33H  
 [7]=37H      [C]=43H  
 [4]=34H      [8]=38H

| n         | K1  | K2  | K3  | K4  | K5  | K6  | K7  | K8  | K9  |
|-----------|-----|-----|-----|-----|-----|-----|-----|-----|-----|
| D         |     |     |     |     |     |     |     |     |     |
| D200 down | [C] | [B] | [A] | [0] | [4] | [3] | [2] | [1] | [8] |
| D200 up   |     | [C] | [B] | [A] | [0] | [4] | [3] | [2] | [1] |
| D201 down |     |     | [C] | [B] | [A] | [0] | [4] | [3] | [2] |
| D201 up   |     |     |     | [C] | [B] | [A] | [0] | [4] | [3] |
| D202 down |     |     |     |     | [C] | [B] | [A] | [0] | [4] |
| D202 up   |     |     |     |     |     | [C] | [B] | [A] | [0] |
| D203 down |     |     |     |     |     |     | [C] | [B] | [A] |
| D203 up   |     |     |     |     |     |     |     | [C] | [B] |
| D204 down |     |     |     |     |     |     |     |     | [C] |

**4-8-7. ASCII converts to hex. [HEX]**

1. Summary

| ASCII converts to Hex. [HEX] |                                      |                      |                 |
|------------------------------|--------------------------------------|----------------------|-----------------|
| 16 bits                      | HEX                                  | 32 bits              | -               |
| Execution condition          | Normally ON/OFF, rising/falling edge | Suitable Models      | XC2.XC3.XC5.XCM |
| Hardware requirement         | -                                    | Software requirement | -               |

2. Operands

| Operands | Function                    | Date type    |
|----------|-----------------------------|--------------|
| S        | Source soft element address | ASCII        |
| D        | Target soft element address | 2 bits, HEX  |
| n        | Character quantity          | 16 bits, BIN |

3. Suitable soft components

| Word | Operands | System |    |    |    |    |    |    |    | Constant | Module |    |    |
|------|----------|--------|----|----|----|----|----|----|----|----------|--------|----|----|
|      |          | D      | FD | ED | TD | CD | DX | DY | DM | DS       | K/H    | ID | QD |
| S    |          | •      | •  |    | •  | •  | •  | •  | •  | •        |        |    |    |
| D    |          | •      |    |    | •  | •  |    | •  | •  | •        |        |    |    |
| n    |          |        |    |    |    |    |    |    |    |          | •      |    |    |

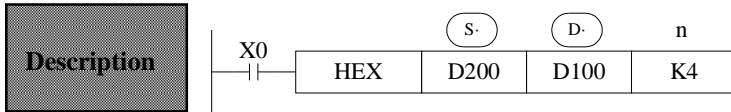

Convert the high and low 8 bits in source (S) to HEX data. Move 4 bits every time to destination (D). The convert alphanumeric number is assigned by n.

| (S)       | ASCII Code | HEX Convert | n                  | (D) | D102  | D101  | D100  |
|-----------|------------|-------------|--------------------|-----|-------|-------|-------|
| D200 down | 30H        | 0           | Not change to be 0 | 1   | 0     | 0     | ...0H |
| D200 up   | 41H        | A           |                    | 2   |       |       | ..0AH |
| D201 down | 42H        | B           |                    | 3   |       |       | .0ABH |
| D201 up   | 43H        | C           |                    | 4   |       |       | 0ABCH |
| D202 down | 31H        | 1           |                    | 5   | ...0H | ABC1H |       |
| D202 up   | 32H        | 2           |                    | 6   | ..0AH | BC12H |       |
|           |            |             |                    | 7   | .0ABH | C123H |       |
|           |            |             |                    | 8   | 0ABCH | 1234H |       |
|           |            |             |                    | 9   | ...0H | ABC1H | 2345H |

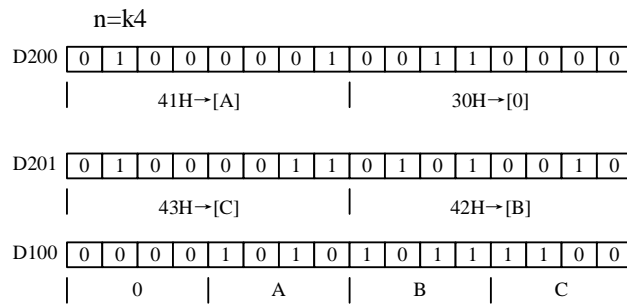

**4-8-8. Coding [DECO]**

1. Summary

Transform the ASCII code to Hex numbers.

| Coding [DECO]        |                                      |                      |                 |
|----------------------|--------------------------------------|----------------------|-----------------|
| 16 bits              | DECO                                 | s                    | -               |
| Execution condition  | Normally ON/OFF, rising/falling edge | Suitable Models      | XC2.XC3.XC5.XCM |
| Hardware requirement | -                                    | Software requirement | -               |

## 2. Operands

| Operands | Function                         | Data Type   |
|----------|----------------------------------|-------------|
| S        | Source soft element address      | ASCII       |
| D        | Target soft element address      | 2 bits HEX  |
| n        | The coding soft element quantity | 16bits, BIN |

## 3.Suitable soft components

| Word | Operands | System |    |    |    |    |    |    |    | Constant | Module |    |
|------|----------|--------|----|----|----|----|----|----|----|----------|--------|----|
|      | D        | FD     | ED | TD | CD | DX | DY | DM | DS | K/H      | ID     | QD |
| S    | •        | •      |    | •  | •  | •  | •  | •  | •  |          |        |    |
| n    |          |        |    |    |    |    |    |    |    | •        |        |    |

| Bit | Operands | System |   |   |   |   |     |  |
|-----|----------|--------|---|---|---|---|-----|--|
|     | X        | Y      | M | S | T | C | Dnm |  |
| D   | •        | •      | • | • | • | • |     |  |

**Description**

< When  $n \leq 16$  bit unit >

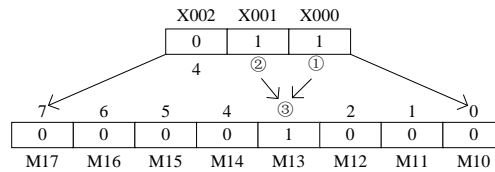
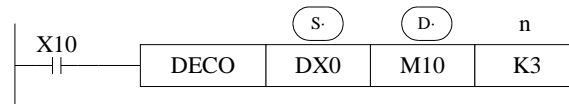

- The source address is  $1+2=3$ , so starts from M10, the number 3 bit (M13) is 1. If the source is all 0, M10 is 1.
- When  $n=0$ , no operation, beyond  $n=0\sim 16$ , don't execute the instruction.
- When  $n=16$ , if coding command  $\textcircled{D}$  is soft unit, it's point is  $2^{16}=65536$ .
- When drive input is OFF, instructions are not executed, the activated coding output keep on activate.

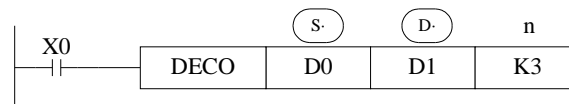

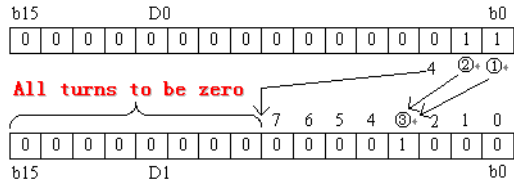

- Low  $n$  bits ( $n \leq 4$ ) of source address are decoded to target address.  $n \leq 3$ , the high bit of target address all become 0.
- When  $n=0$ , no operation, beyond  $n=0 \sim 14$ , don't execute the instruction.

### 4-8-9. High bit coding [ENCO]

#### 1. Summary

Transform the ASCII code to hex numbers

| High bit coding [ENCO] |                              |                      |                 |
|------------------------|------------------------------|----------------------|-----------------|
| 16 bits                | ENCO                         | 32 bits              | -               |
| Execution condition    | Normally rising/falling edge | Suitable Models      | XC2.XC3.XC5.XCM |
| Hardware requirement   | -                            | Software requirement | -               |

#### 2. Operands

| Operands | Function                             | Data Type         |
|----------|--------------------------------------|-------------------|
| S        | data address need coding             | 16 bits, BIN; bit |
| D        | Coding result address                | 16 bits, BIN      |
| n        | soft element quantity to save result | 16 bits, BIN      |

#### 3. Suitable soft components

| Word | Operands | System |    |    |    |    |    |    |    | Constant | Module |    |    |
|------|----------|--------|----|----|----|----|----|----|----|----------|--------|----|----|
|      |          | D      | FD | ED | TD | CD | DX | DY | DM | DS       | K/H    | ID | QD |
| S    |          | •      | •  |    | •  | •  | •  | •  | •  | •        |        |    |    |
| D    |          | •      |    |    | •  | •  |    | •  | •  | •        |        |    |    |
| n    |          |        |    |    |    |    |    |    |    |          | •      |    |    |

| Bit | Operands | System |   |   |   |   |   |      |
|-----|----------|--------|---|---|---|---|---|------|
|     |          | X      | Y | M | S | T | C | Dn.m |
| S   |          | •      | • | • | • | • | • |      |

**Description**

< When (S) is bit device >  $n \leq 16$

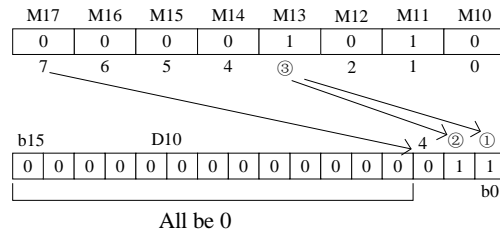
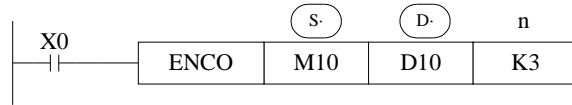

< When (S) is word device >  $n \leq 4$

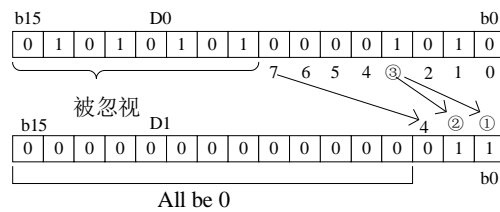
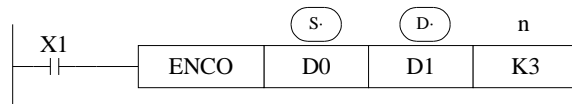

- If many bits in the source ID are 1, ignore the low bits. If source ID are all 0, don't execute the instructions.
- When drive input is OFF, the instruction is not executed, encode output don't change.
- When  $n=8$ , if encode instruction's "S" is bit unit, it's point number is  $2^8=256$

**4-8-10. Low bit coding [ENCOL]**

1. Summary

Transform the ASCII to hex numbers.

| Low bit coding [ENCOL] |                                      |                      |                 |
|------------------------|--------------------------------------|----------------------|-----------------|
| 16 bits                | ENCOL                                | 32 bits              | -               |
| Execution condition    | Normally ON/OFF, rising/falling edge | Suitable Models      | XC2.XC3.XC5.XCM |
| Hardware requirement   | -                                    | Software requirement | -               |

## 2. Operands

| Operands | Function                                   | Data Type      |
|----------|--|----------------|
| S        | Soft element address need coding           | 16bit,BIN; bit |
| D        | Soft element address to save coding result | 16bit,BIN      |
| n        | The soft element quantity to save result   | 16bit,BIN      |

### ● Suitable soft components

| Word | Operands | System |    |    |    |    |    |    |    | Constant | Module |    |    |
|------|----------|--------|----|----|----|----|----|----|----|----------|--------|----|----|
|      |          | D      | FD | ED | TD | CD | DX | DY | DM | DS       | K/H    | ID | QD |
| S    |          | •      | •  |    | •  | •  | •  | •  | •  | •        |        |    |    |
| D    |          | •      |    |    | •  | •  |    | •  | •  | •        |        |    |    |
| n    |          |        |    |    |    |    |    |    |    | •        |        |    |    |

| Bit | Operands | System |   |   |   |   |   |     |
|-----|----------|--------|---|---|---|---|---|-----|
|     |          | X      | Y | M | S | T | C | Dnm |
| S   |          | •      | • | • | • | • | • |     |

**Description**

< if (s) is bit device >  $n \leq 16$

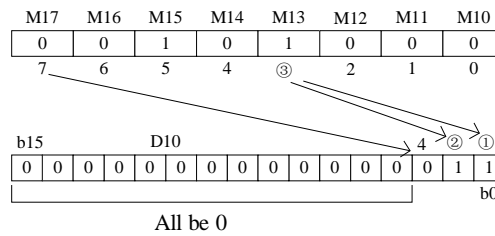
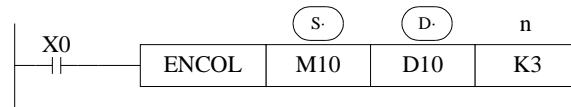

< if (s) is word device >  $n \leq 4$

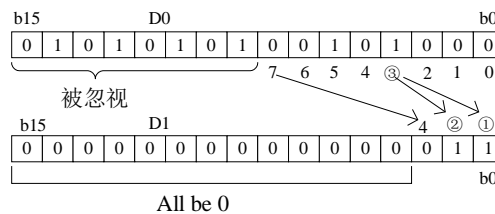
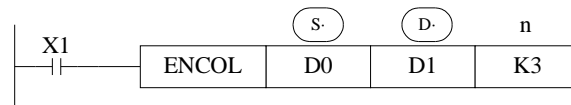

- If many bits in the source ID are 1, ignore the high bits. If source ID are all 0, don't execute the instructions.
- When drive input is OFF, the instruction is not executed, encode output don't change
- When  $n=8$ , if encode instruction's is bit unit, it's point number is  $2^8=256$

#### 4-9. Floating Operation

| Mnemonic | Function             | Chapter |
|----------|----------------------|---------|
| ECMP     | Float Compare        | 4-9-1   |
| EZCP     | Float Zone Compare   | 4-9-2   |
| EADD     | Float Add            | 4-9-3   |
| ESUB     | Float Subtract       | 4-9-4   |
| EMUL     | Float Multiplication | 4-9-5   |
| EDIV     | Float Division       | 4-9-6   |
| ESQR     | Float Square Root    | 4-9-7   |
| SIN      | Sine                 | 4-9-8   |
| COS      | Cosine               | 4-9-9   |
| TAN      | Tangent              | 4-9-10  |
| ASIN     | ASIN                 | 4-9-11  |
| ACOS     | ACOS                 | 4-9-12  |
| ATAN     | ATAN                 | 4-9-13  |

## 4-9-1. Float Compare [ECMP]

### 1. Summary

| Float Compare [ECMP] |                              |                         |                 |
|----------------------|------------------------------|-------------------------|-----------------|
| 16 bits              | -                            | 32 bits                 | ECMP            |
| Execution condition  | Normally rising/falling edge | ON/OFF, Suitable Models | XC2.XC3.XC5.XCM |
| Hardware requirement | -                            | Software requirement    | -               |

### 2. Operands

| Operands | Function                          | Data Type    |
|----------|-----------------------------------|--------------|
| S1       | Soft element address need compare | 32 bits, BIN |
| S2       | Soft element address need compare | 32 bits, BIN |
| D        | Compare result                    | bit          |

### 3. Suitable soft components

| Word | Operands | System |    |    |    |    |    |    |    | Constant | Module |    |    |
|------|----------|--------|----|----|----|----|----|----|----|----------|--------|----|----|
|      |          | D      | FD | ED | TD | CD | DX | DY | DM | DS       | K/H    | ID | QD |
|      | S1       | •      | •  |    |    |    | •  | •  | •  | •        | •      |    |    |
|      | S2       | •      | •  |    |    |    | •  | •  | •  | •        | •      |    |    |

| Bit | Operands | System |   |   |   |   |   |     |
|-----|----------|--------|---|---|---|---|---|-----|
|     |          | X      | Y | M | S | T | C | Dnm |
|     | D        |        | • | • | • |   |   |     |

### Description

(D11,D10) : (D21,D20) → M0,M1,M2  
 Binary Floating Binary Floating

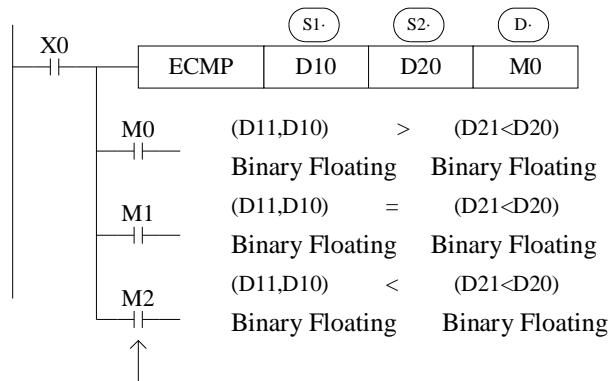

The status of the destination device will be kept even if the ECMP instruction is deactivated.

- The binary float data of S1 is compared to S2. The result is indicated by 3 bit devices specified with the head address entered as D
- If a constant K or H used as source data, the value is converted to floating point before the addition operation.

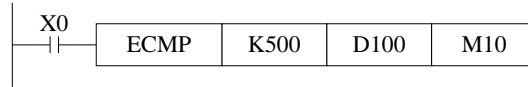

(K500) : (D101, D100) → M10, M11, M12

Binary converts to floating      Binary floating to floating

#### 4-9-2. Float Zone Compare [EZCP]

##### 1. Summary

| Float Zone Compare [EZCP] |                              |                         |                 |
|---------------------------|------------------------------|-------------------------|-----------------|
| 16 bits                   | -                            | 32 bits                 | EZCP            |
| Execution condition       | Normally rising/falling edge | ON/OFF, Suitable Models | XC2.XC3.XC5.XCM |
| Hardware requirement      | -                            | Software requirement    | -               |

##### 2. Operands

| Operands | Function                                | Data Type    |
|----------|---|--------------|
| S1       | Soft element address need compare       | 32 bits, BIN |
| S2       | Upper limit of compare data             | 32 bits, BIN |
| S3       | Lower limit of compare data             | 32 bits, BIN |
| D        | The compare result soft element address | bit          |

##### 3. Suitable soft components

|      |          |        |    |    |    |    |    |      |    |          |        |    |    |
|------|----------|--------|----|----|----|----|----|------|----|----------|--------|----|----|
| Word | Operands | System |    |    |    |    |    |      |    | Constant | Module |    |    |
|      |          | D      | FD | ED | TD | CD | DX | DY   | DM | DS       | K/H    | ID | QD |
|      | S1       | •      | •  |    |    |    | •  | •    | •  | •        | •      |    |    |
|      | S2       | •      | •  |    |    |    | •  | •    | •  | •        | •      |    |    |
|      | S3       | •      | •  |    |    |    | •  | •    | •  | •        | •      |    |    |
| Bit  | Operands | System |    |    |    |    |    |      |    |          |        |    |    |
|      |          | X      | Y  | M  | S  | T  | C  | Dn.m |    |          |        |    |    |
|      | D        |        | •  | •  | •  |    |    |      |    |          |        |    |    |

**Description**

Compare a float range with a float value...

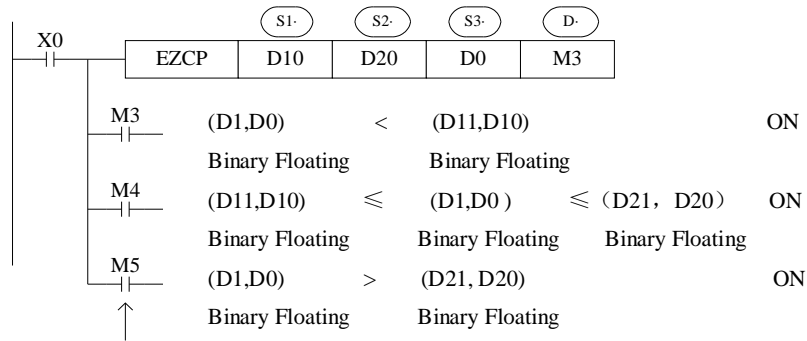

The status of the destination device will be kept even if the EZCP instruction is deactivated.

- The data of S1 is compared to the data of S2. The result is indicated by 3 bit devices specified with the head address entered as D.
- If a constant K or H used as source data, the value is converted to floating point before the addition operation.

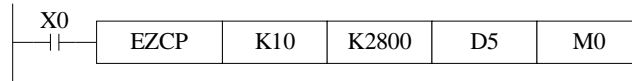

(K10) : [D6,D5] : (K2800) → M0, M1, M2  
 Binary converts Binary Floating Binary converts  
 to Floating to Floating to Floating

Please set S1<S2, when S2>S1, see S2 as the same with S1 and compare them

**4-9-3. Float Add [EADD]**

1. Summary

| Float Add [EADD]     |                                      |                      |                 |
|----------------------|--------------------------------------|----------------------|-----------------|
| 16 bits              | -                                    | 32 bits              | EADD            |
| Execution condition  | Normally ON/OFF, rising/falling edge | Suitable Models      | XC2.XC3.XC5.XCM |
| Hardware requirement | -                                    | Software requirement | -               |

2. Operands

| Operands | Function                         | Data Type    |
|----------|----------------------------------|--------------|
| S1       | Soft element address need to add | 32 bits, BIN |
| S2       | Soft element address need to add | 32 bits, BIN |
| D        | Result address                   | 32 bits, BIN |

### 3. Suitable soft components

| Word | Operands | System |    |    |    |    |    |    |    | Constant | Module |    |    |
|------|----------|--------|----|----|----|----|----|----|----|----------|--------|----|----|
|      |          | D      | FD | ED | TD | CD | DX | DY | DM | DS       | K/H    | ID | QD |
| S1   |          | •      | •  |    |    |    | •  | •  | •  | •        | •      |    |    |
| S2   |          | •      | •  |    |    |    | •  | •  | •  | •        | •      |    |    |
| D    |          | •      |    |    |    |    |    | •  | •  | •        |        |    |    |

**Description**



$$\begin{array}{ccc}
 (D11,D10) & + & (D21,D20) \rightarrow (D51,D50) \\
 \text{Binary Floating} & & \text{Binary Floating} \quad \text{Binary Floating}
 \end{array}$$

- The floating point values stored in the source devices S1 and S2 are algebraically added and the result stored in the destination device D.
- If a constant K or H used as source data, the value is converted to floating point before the addition operation.

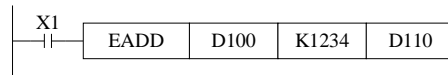

$$\begin{array}{ccc}
 (K1234) & + & (D101,D100) \rightarrow (D111,D110) \\
 \text{Binary converts to Floating} & & \text{Binary Floating} \quad \text{Binary Floating}
 \end{array}$$

- The same device may be used as a source and as the destination. If this is the case then, on continuous operation of the EADD instruction, the result of the previous operation will be used as a new source value and a new result calculated. This will happen every program scan unless the pulse modifier or an interlock program is used.

#### 4-9-4. Float Sub [ESUB]

##### 1. Summary

| Float Sub [ESUB]     |                                      |                      |                 |
|----------------------|--------------------------------------|----------------------|-----------------|
| 16 bits              | -                                    | 32 bits              | ESUB            |
| Execution condition  | Normally ON/OFF, rising/falling edge | Suitable Models      | XC2.XC3.XC5.XCM |
| Hardware requirement | -                                    | Software requirement | -               |

## 2. Operands

| Operands | Function                              | Data Type    |
|----------|---------------------------------------|--------------|
| S1       | Soft element address need to subtract | 32 bits, BIN |
| S2       | Soft element address need to subtract | 32 bits, BIN |
| D        | Result address                        | 32 bits, BIN |

## 3. Suitable soft components

| Word | Operands | System |    |    |    |    |    |    |    | Constant | Module |    |    |
|------|----------|--------|----|----|----|----|----|----|----|----------|--------|----|----|
|      |          | D      | FD | ED | TD | CD | DX | DY | DM | DS       | K/H    | ID | QD |
| S1   | •        | •      |    |    |    |    | •  | •  | •  | •        | •      |    |    |
| S2   | •        | •      |    |    |    |    | •  | •  | •  | •        | •      |    |    |
| D    | •        |        |    |    |    |    |    | •  | •  | •        |        |    |    |

**Description**

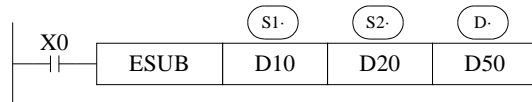

(D11,D10)    −    (D21,D20)    →    (D51,D50)  
 Binary Floating      Binary Floating      Binary Floating

- The floating point value of S2 is subtracted from the floating point value of S1 and the result stored in destination device D.
- If a constant K or H used as source data, the value is converted to floating point before the addition operation.

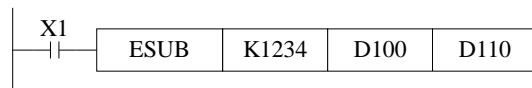

(K1234)                    −    (D101,D100)    →    (D111,D110)  
 Binary converts to Floating    Binary Floating      Binary Floating

- The same device may be used as a source and as the destination. If this is the case then, on continuous operation of the EADD instruction, the result of the previous operation will be used as a new source value and a new result calculated. This will happen every program scan unless the pulse modifier or an interlock program is used.

## 4-9-5. Float Mul[EMUL]

### 1. Summary

| Float Multiply [EMUL] |                              |                         |                 |
|-----------------------|------------------------------|-------------------------|-----------------|
| 16 bits               | -                            | 32 bits                 | EMUL            |
| Execution condition   | Normally rising/falling edge | ON/OFF, Suitable Models | XC2.XC3.XC5.XCM |
| Hardware requirement  | -                            | Software requirement    | -               |

### 2. Operands

| Operands | Function                              | Data Type    |
|----------|---------------------------------------|--------------|
| S1       | Soft element address need to multiply | 32 bits, BIN |
| S2       | Soft element address need to multiply | 32 bits, BIN |
| D        | Result address                        | 32 bits, BIN |

### 3. Suitable soft components

| Word | Operands | System |    |    |    |    |    |    |    | Constant | Module |    |    |
|------|----------|--------|----|----|----|----|----|----|----|----------|--------|----|----|
|      |          | D      | FD | ED | TD | CD | DX | DY | DM | DS       | K/H    | ID | QD |
|      | S1       | •      | •  |    |    |    | •  | •  | •  | •        | •      |    |    |
|      | S2       | •      | •  |    |    |    | •  | •  | •  | •        | •      |    |    |
|      | D        | •      |    |    |    |    |    | •  | •  | •        |        |    |    |

**Description**

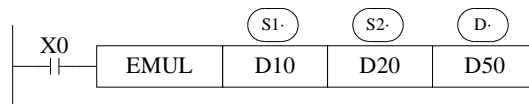

$$\begin{array}{ccc}
 (D11, D10) & \times & (D21, D20) \rightarrow (D51, D50) \\
 \text{Binary Floating} & & \text{Binary Floating} \quad \text{Binary Floating}
 \end{array}$$

- The floating value of S1 is multiplied with the floating value point value of S2. The result of the multiplication is stored at D as a floating value
- If a constant K or H used as source data, the value is converted to floating point before the addition operation.

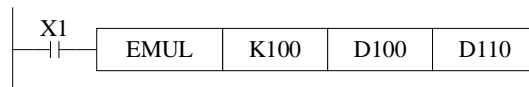

$$\begin{array}{ccc}
 (K100) & \times & (D101, D100) \rightarrow (D111, D110) \\
 \text{Binary converts to Floating} & & \text{Binary Floating} \quad \text{Binary Floating}
 \end{array}$$

## 4-9-6. Float Div [EDIV]

### 1. Summary

| Float Divide [EDIV]  |                              |                         |                 |
|----------------------|------------------------------|-------------------------|-----------------|
| 16 bits              | -                            | 32 bits                 | EDIV            |
| Execution condition  | Normally rising/falling edge | ON/OFF, Suitable Models | XC2.XC3.XC5.XCM |
| Hardware requirement | -                            | Software requirement    | -               |

### 2. Operands

| Operands | Function                            | Data Type    |
|----------|-------------------------------------|--------------|
| S1       | Soft element address need to divide | 32 bits, BIN |
| S2       | Soft element address need to divide | 32 bits, BIN |
| D        | Result address                      | 32 bits, BIN |

### 3. Suitable soft components

| word | Operands | System |    |    |    |    |    |    |    | Constant | Module |    |    |
|------|----------|--------|----|----|----|----|----|----|----|----------|--------|----|----|
|      |          | D      | FD | ED | TD | CD | DX | DY | DM | DS       | K/H    | ID | QD |
| S1   |          | •      | •  |    |    |    | •  | •  | •  | •        | •      |    |    |
| S2   |          | •      | •  |    |    |    | •  | •  | •  | •        | •      |    |    |
| D    |          | •      |    |    |    |    |    | •  | •  | •        |        |    |    |

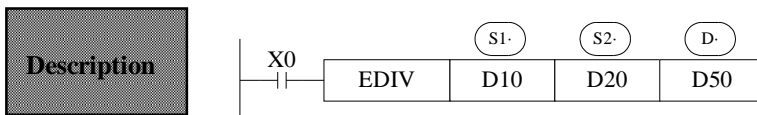

$$(D11, D10) \div (D21, D20) \rightarrow (D51, D50)$$

Binary Floating      Binary Floating      Binary Floating

- The floating point value of S1 is divided by the floating point value of S2. The result of the division is stored in D as a floating point value. No remainder is calculated.
- If a constant K or H used as source data, the value is converted to floating point before the addition operation

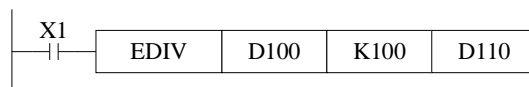

$$(D101, D100) \div (K100) \rightarrow (D111, D110)$$

Binary converts to Floating      Binary Floating      Binary Floating

If S2 is 0, the calculate is error, the instruction can not work

## 4-9-7. Float Square Root [ESQR]

### 1. Summary

| Float Square Root [ESQR] |                              |                         |                 |
|--------------------------|------------------------------|-------------------------|-----------------|
| 16 bits                  | -                            | 32 bits                 | ESQR            |
| Execution condition      | Normally rising/falling edge | ON/OFF, Suitable Models | XC2.XC3.XC5.XCM |
| Hardware requirement     | -                            | Software requirement    | -               |

### 2. Operands

| Operands | Function  | Data Type    |
|----------|---|--------------|
| S        | The soft element address need to do square root | 32 bits, BIN |
| D        | The result address                              | 32 bits, BIN |

### 3. Suitable soft components

| Word | Operands | System |    |    |    |    |    |    |    | Constant | Module |    |    |
|------|----------|--------|----|----|----|----|----|----|----|----------|--------|----|----|
|      |          | D      | FD | ED | TD | CD | DX | DY | DM | DS       | K/H    | ID | QD |
| S    |          | •      | •  |    |    |    | •  | •  | •  | •        | •      |    |    |
| D    |          | •      |    |    |    |    |    | •  | •  | •        |        |    |    |

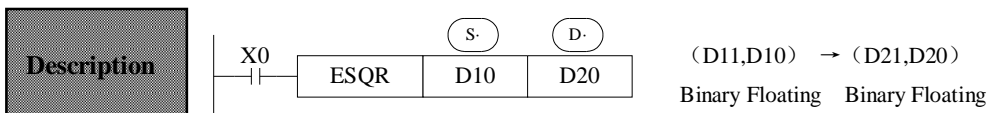

- A square root is performed on the floating point value in S the result is stored in D
- If a constant K or H used as source data, the value is converted to floating point before the addition operation.

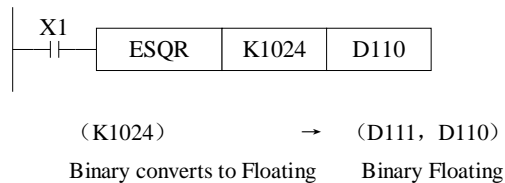

- When the result is zero, zero flag activates.
- Only when the source data is positive will the operation be effective. If S is negative then an error occurs and error flag M8067 is set ON, the instruction can't be executed.

## 4-9-8. Sine [SIN]

### 1. Summary

| Float Sine[SIN]      |                              |                         |                 |
|----------------------|------------------------------|-------------------------|-----------------|
| 16 bits              | -                            | 32 bits                 | SIN             |
| Execution condition  | Normally rising/falling edge | ON/OFF, Suitable Models | XC2.XC3.XC5.XCM |
| Hardware requirement | -                            | Software requirement    | -               |

### 2. Operands

| Operands | Function                                 | Data Type    |
|----------|--|--------------|
| S        | The soft element address need to do sine | 32 bits, BIN |
| D        | The result address                       | 32 bits, BIN |

### 3. Suitable soft components

| Word | Operands | System |    |    |    |    |    |    |    | Constant | Module |    |    |
|------|----------|--------|----|----|----|----|----|----|----|----------|--------|----|----|
|      |          | D      | FD | ED | TD | CD | DX | DY | DM | DS       | K/H    | ID | QD |
| S    |          | •      | •  |    |    |    | •  | •  | •  | •        | •      |    |    |
| D    |          | •      |    |    |    |    |    | •  | •  | •        |        |    |    |

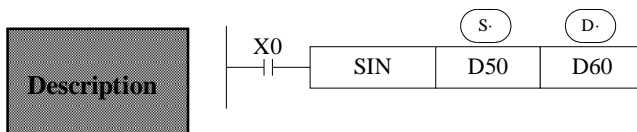

(D51,D50) → (D61,D60)SIN  
Binary Floating Binary Floating

- This instruction performs the mathematical SIN operation on the floating point value in S (angle RAD). The result is stored in D.

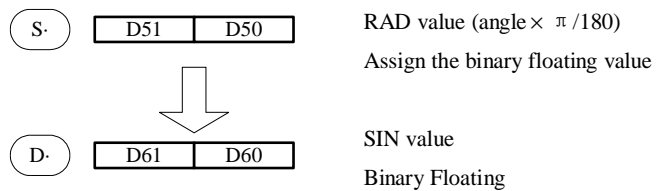

## 4-9-9. Cosine [SIN]

### 1. Summary

| Float Cosine[COS]    |                              |                         |                 |
|----------------------|------------------------------|-------------------------|-----------------|
| 16 bits              | -                            | 32 bits                 | COS             |
| Execution condition  | Normally rising/falling edge | ON/OFF, Suitable Models | XC2.XC3.XC5.XCM |
| Hardware requirement | -                            | Software requirement    | -               |

### 2. Operands

| Operands | Function                            | Data Type    |
|----------|-------------------------------------|--------------|
| S        | Soft element address need to do cos | 32 bits, BIN |
| D        | Result address                      | 32 bits, BIN |

### 3. Suitable soft components

| Word | Operands | System |    |    |    |    |    |    |    | Constant | Module |    |    |
|------|----------|--------|----|----|----|----|----|----|----|----------|--------|----|----|
|      |          | D      | FD | ED | TD | CD | DX | DY | DM | DS       | K/H    | ID | QD |
| S    |          | •      | •  |    |    |    | •  | •  | •  | •        | •      |    |    |
| D    |          | •      |    |    |    |    |    | •  | •  | •        |        |    |    |

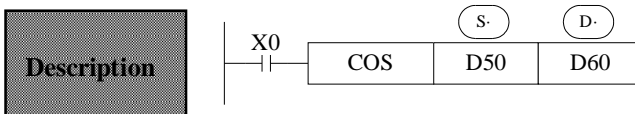

(D51, D50)RAD → (D61, D60)COS  
Binary Floating Binary Floating

- This instruction performs the mathematical COS operation on the floating point value in S (angle RAD). The result is stored in D

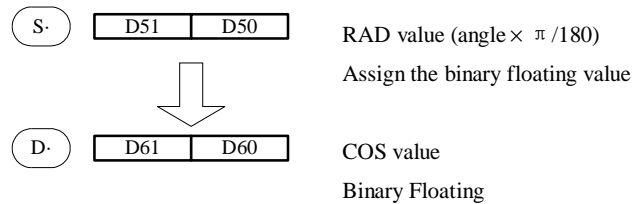

## 4-9-10. TAN [TAN]

### 1. Summary

| TAN [TAN]            |                              |                         |                 |
|----------------------|------------------------------|-------------------------|-----------------|
| 16 bits              | -                            | 32 bits                 | TAN             |
| Execution condition  | Normally rising/falling edge | ON/OFF, Suitable Models | XC2.XC3.XC5.XCM |
| Hardware requirement | -                            | Software requirement    | -               |

### 2. Operands

| Operands | Function                            | Data Type |
|----------|-------------------------------------|-----------|
| S        | Soft element address need to do tan | 32bit,BIN |
| D        | Result address                      | 32bit,BIN |

### 3. Suitable soft components

| Word | Operands | System |    |    |    |    |    |    |    | Constant | Module |    |    |
|------|----------|--------|----|----|----|----|----|----|----|----------|--------|----|----|
|      |          | D      | FD | ED | TD | CD | DX | DY | DM | DS       | K/H    | ID | QD |
| S    |          | •      | •  |    |    |    | •  | •  | •  | •        | •      |    |    |
| D    |          | •      |    |    |    |    |    | •  | •  | •        |        |    |    |

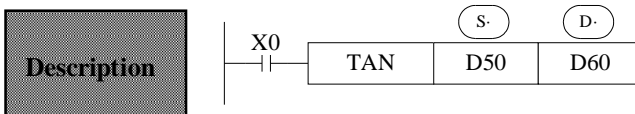

(D51,D50)RAD → (D61,D60)TAN  
Binary Floating      Binary Floating

- This instruction performs the mathematical TAN operation on the floating point value in S. The result is stored in D.

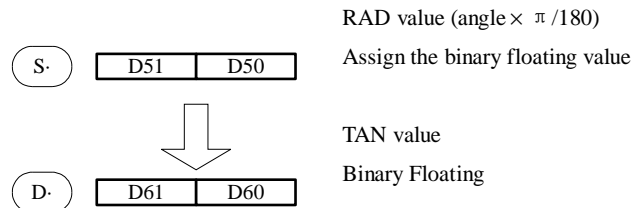

## 4-9-11. ASIN [ASIN]

### 1. Summary

| ASIN [ASIN]          |                                      |                      |                 |
|----------------------|--------------------------------------|----------------------|-----------------|
| 16 bits              | -                                    | 32 bits              | ASIN            |
| Execution condition  | Normally ON/OFF, rising/falling edge | Suitable Models      | XC2.XC3.XC5.XCM |
| Hardware requirement | V3.0 and above version               | Software requirement | -               |

### 2. Operands

| Operands | Function                               | Data Type    |
|----------|--|--------------|
| S        | Soft element address need to do arcsin | 32 bits, BIN |
| D        | Result address                         | 32 bits, BIN |

### 3. Suitable soft components

| Word | Operands | System |    |    |    |    |    |    |    | Constant | Module |    |    |
|------|----------|--------|----|----|----|----|----|----|----|----------|--------|----|----|
|      |          | D      | FD | ED | TD | CD | DX | DY | DM | DS       | K/H    | ID | QD |
| S    |          | •      | •  |    |    |    | •  | •  | •  | •        | •      |    |    |
| D    |          | •      |    |    |    |    |    | •  | •  | •        |        |    |    |

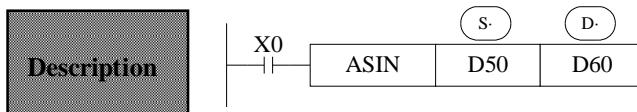

(D51,D50)ASIN → (D61,D60)RAD  
 Binary Floating Binary Floating

- This instruction performs the mathematical ASIN operation on the floating point value in S. The result is stored in D.

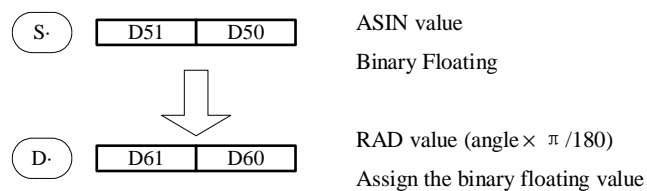

## 4-9-12. ACOS [ACOS]

### 1. Summary

| ACOS [ACOS]          |                              |                         |                 |
|----------------------|------------------------------|-------------------------|-----------------|
| 16 bits              | -                            | 32 bits                 | ACOS            |
| Execution condition  | Normally rising/falling edge | ON/OFF, Suitable Models | XC2.XC3.XC5.XCM |
| Hardware requirement | V3.0 and above               | Software requirement    | -               |

### 2. Operands

| Operands | Function                               | Data Type    |
|----------|--|--------------|
| S        | Soft element address need to do arccos | 32 bits, BIN |
| D        | Result address                         | 32 bits, BIN |

### 3. Suitable soft components

| Word | Operands | System |    |    |    |    |    |    |    | Constant | Module |    |    |
|------|----------|--------|----|----|----|----|----|----|----|----------|--------|----|----|
|      |          | D      | FD | ED | TD | CD | DX | DY | DM | DS       | K/H    | ID | QD |
| S    |          | •      | •  |    |    |    | •  | •  | •  | •        | •      |    |    |
| D    |          | •      |    |    |    |    |    | •  | •  | •        |        |    |    |

**Description**

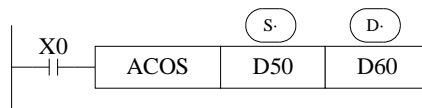

(D51,D50)ACOS → (D61,D60)RAD  
 Binary Floating      Binary Floating

- Calculate the arcos value(radian), save the result in the target address

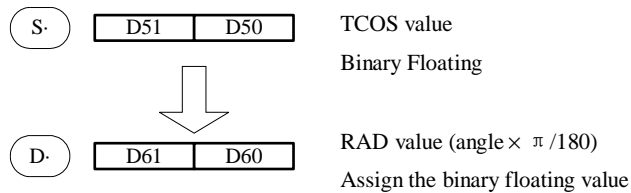



## 4-10. RTC Instructions

| Mnemonic | Function         | Chapter |
|----------|------------------|---------|
| TRD      | Clock data read  | 4-10-1  |
| TWR      | Clock data write | 4-10-2  |

※1: To use the instructions, The Model should be equipped with RTC function;

### 4-10-1. Read the clock data [TRD]

#### 1. Instruction Summary

Read the clock data:

| Read the clock data: [TRD] |                                      |                      |                 |
|----------------------------|--------------------------------------|----------------------|-----------------|
| 16 bits                    | TRD                                  | 32 bits              | -               |
| Execution condition        | Normally ON/OFF, rising/falling edge | Suitable Models      | XC2.XC3.XC5.XCM |
| Hardware requirement       | V2.51 and above                      | Software requirement | -               |

#### 2. Operands

| Operands | Function                    | Data Type    |
|----------|-----------------------------|--------------|
| D        | Register to save clock data | 16 bits, BIN |

#### 3. Suitable Soft Components

| Word | Operands | System |    |    |    |    |    |    |    | Constant | Module |    |    |
|------|----------|--------|----|----|----|----|----|----|----|----------|--------|----|----|
|      |          | D      | FD | ED | TD | CD | DX | DY | DM | DS       | K/H    | ID | QD |
| D    | •        |        |    |    | •  | •  |    |    |    |          |        |    |    |

**Functions and Actions**

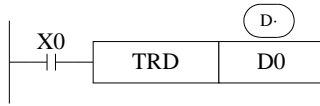

The current time and date of the real time clock are read and stored in the 7 data devices specified by the head address D.

- Read PLC's real time clock according to the following format.  
The reading source is the special data register (D8013~D8019) which save clock data.

|   |       | Unit   | Item | Clock data        |   | Unit | Item   |
|---|-------|--------|------|-------------------|---|------|--------|
| Special data register for real time clock | D8018 | Year   |      | 0-99              | → | D0   | Year   |
|   | D8017 | Month  |      | 1-12              | → | D1   | Month  |
|   | D8016 | Date   |      | 1-31              | → | D2   | Date   |
|   | D8015 | Hour   |      | 0-23              | → | D3   | Hour   |
|   | D8014 | Minute |      | 0-59              | → | D4   | Minute |
|   | D8013 | Second |      | 0-59              | → | D5   | Second |
|   | D8019 | Week   |      | 0 (Sun.)-6 (Sat.) | → | D    | Week   |

**4-10-2. Write Clock Data [TWR]**

1. Instruction Summary

Write the clock data:

| Write clock data [TRD] |                              |                         |                 |
|------------------------|------------------------------|-------------------------|-----------------|
| 16 bits                | -                            | 32 bits                 | TRD             |
| Execution condition    | Normally rising/falling edge | ON/OFF, Suitable Models | XC2.XC3.XC5.XCM |
| Hardware requirement   | V2.51 and above              | Software requirement    | -               |

2. Operands

| Operands | Function                             | Data Type    |
|----------|--------------------------------------|--------------|
| S        | Write the clock data to the register | 16 bits, BIN |

3. Suitable Soft Components

| Word | Operands | System |    |    |    |    |    |    |    | Constant | Module |    |    |
|------|----------|--------|----|----|----|----|----|----|----|----------|--------|----|----|
|      |          | D      | FD | ED | TD | CD | DX | DY | DM | DS       | K/H    | ID | QD |
| S    |          | •      | •  |    | •  | •  | •  | •  | •  | •        |        |    |    |

**Functions and Actions**

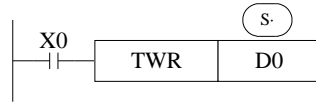

The 7 data devices specified with the head address S are used to set a new current value of the real time clock.

- Write the set clock data into PLC's real time clock.  
In order to write real time clock, the 7 data devices specified with the head address (S) should be pre-set.

|                        | Unit | Item   | Clock data        |   | Unit  | Item   |   |
|------------------------|------|--------|-------------------|---|-------|--------|---|
| Data for clock setting | D10  | Year   | 0-99              | → | D8018 | Year   | Special data register for real time clock t |
|                        | D11  | Month  | 1-12              | → | D8017 | Month  |   |
|                        | D12  | Date   | 1-31              | → | D8016 | Date   |   |
|                        | D13  | Hour   | 0-23              | → | D8015 | Hour   |   |
|                        | D14  | Minute | 0-59              | → | D8014 | Minute |   |
|                        | D15  | Second | 0-59              | → | D8013 | Second |   |
|                        | D16  | Week   | 0 (Sun.)-6 (Sat.) | → | D8019 | Week   |   |

After executing TWR instruction, the time in real time clock will immediately change to be the new set time. So, when setting the time it is a good idea to set the source data to a time a number of minutes ahead and then drive the instruction when the real time reaches this value.

## 5 High speed counter (HSC)

---

In this chapter we tell high speed counter's functions, including high speed count model, wiring method, read/write HSC value, reset etc.

5-1. FUNCTIONS SUMMARY

5-2. HIGH SPEED COUNTER'S MODE

5-3. HIGH SPEED COUNTER'S RANGE

5-4. INPUT WIRING OF HIGH SPEED COUNTER

5-5. INPUT TERMINALS ASSIGNMENT FOR HSC

5-6. READ AND WRITE THE HSC VALUE



5-7. RESET MODE OF HSC

5-8. FREQUENCY MULTIPLICATION OF AB PHASE HSC

5-9. HSC EXAMPLES

5-10. HSC INTERRUPTION

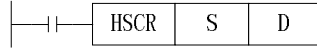
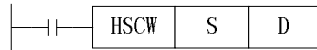
Instructions List for HSC

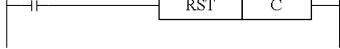
| MNEMONIC                             | FUNCTION                     | CIRCUIT AND SOFTWARE COMPONENTS  | CHAPTER |
|--------------------------------------|------------------------------|--|---------|
| <b>READ/WRITE HIGH SPEED COUNTER</b> |                              |  |         |
| HSCR                                 | Read HSC                     |  | 5-6-1   |
| HSCW                                 | Write HSC                    |  | 5-6-2   |
| OUT                                  | HSC (High Speed Counter)     |  | 3-13    |
| OUT                                  | 24 segments HSC Interruption |  | 5-10    |
| RST                                  | HSC Reset                    |  | 3-13    |

**5-1. Functions Summary**

XC series PLC has HSC (High Speed Counter) function which is independent with the scan cycle. Via choosing different counter, test the high speed input signals with detect sensors and rotary encoders. The highest testing frequency can reach 80 KHz.

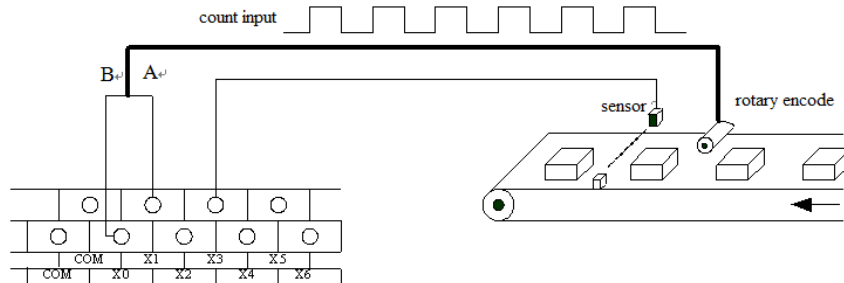

**5-2. HSC Mode**

XC series high speed counters function has three count modes: Increment Mode, Pulse + Direction Mode and AB phase Mode;

**Increment Mode**

Under this mode, count and input the pulse signal, the count value increase at each pulse's rising edge;

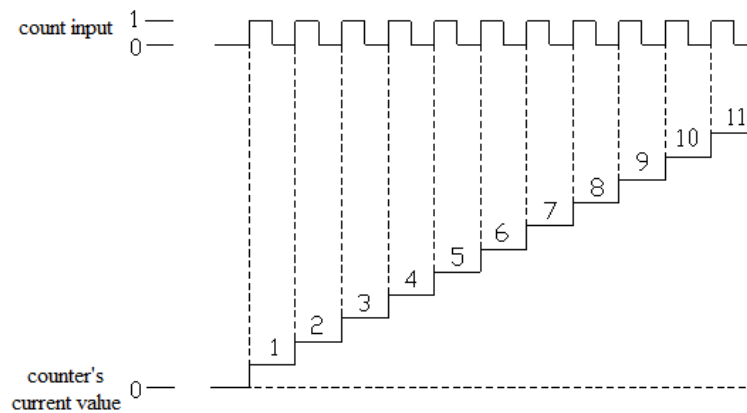

### Pulse + Direction Mode

Under this mode, the pulse signal and direction signal are all inputted, the count value increase or decrease with the direction signal's status. When the count signal is OFF, the count input's rising edge carry on plus count; When the count signal is ON, the count input's rising edge carry on minus count;

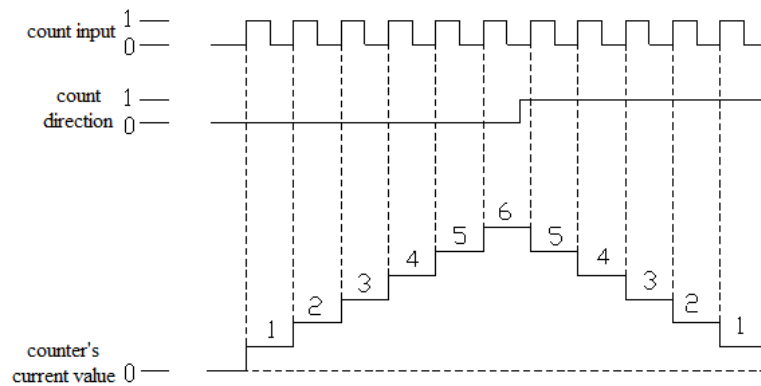

### AB Phase Mode

Under this mode, the HSC value increase or decrease according to two differential signal (A phase and B phase). According to the multiplication, we have 1-time frequency and 4-time frequency two modes, but the default count mode is 4-time mode.

1-time frequency and 4-time frequency modes are shown below:

#### ➤ 1-time Frequency

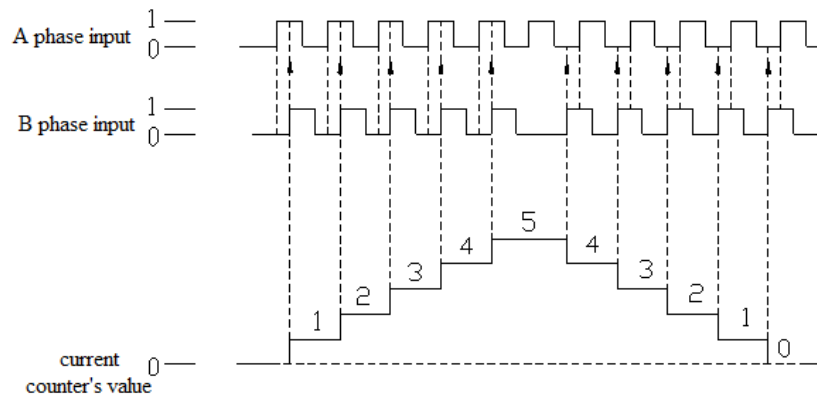

➤ 4-time Frequency

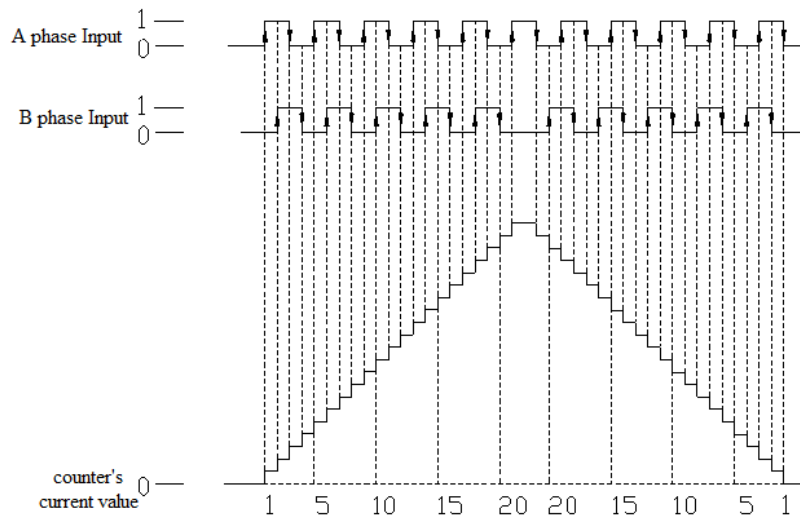

**5-3. HSC Range**

HSC's count range is:  $K-2,147,483,648 \sim K+2,147,483,647$ . If the count value overflows this range, then up flow or down flow appears; For "up flow", it means the count value jumps from  $K+2,147,483,647$  to be  $K-2,147,483,648$ , and then continue to count; for "down flow", it means the count value jumps from  $K-2,147,483,648$  to be  $K+2,147,483,647$  then continue to count.

**5-4. HSC Input Wiring**

For the counter's pulse input wiring, things differ with different PLC model and counter model; several typical input wiring are shown below: (take XC3-48 as the example):

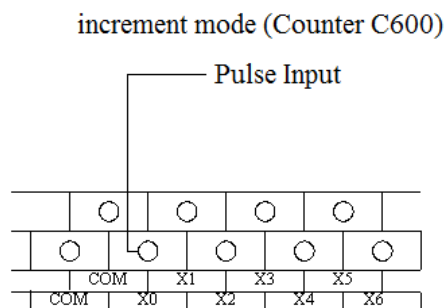

Pulse+Direction Mode (C620)

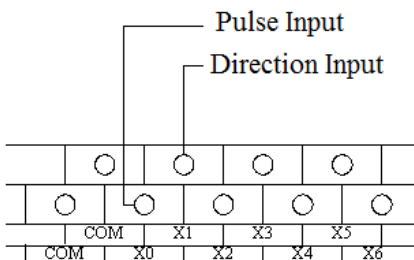

AB phase Mode (C630)

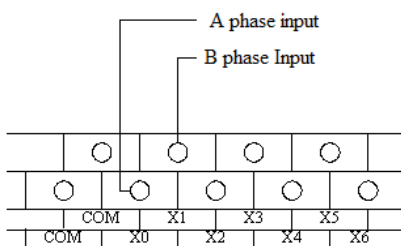

**5-5. HSC ports assignment**

Each letter's meaning:

| U           | Dir   | A             | B             |
|-------------|---|---------------|---------------|
| Pulse input | Count Direction Judgment<br>(OFF=increment, ON=decrement) | A phase input | B phase input |

Normally, X0 and X1 can accept 80 KHz frequency under single phase mode and AB phase mode. Other terminals can accept only 10 KHz under single phase mode, 5 KHz under AB phase mode. X can use as normal input terminals when they are not used as high speed input. The detailed assignment is shown as below:

| XC2 series PLC  |           |     |     |     |     |     |     |     |     |     |                 |     |     |     |     |               |     |      |
|-----------------|-----------|-----|-----|-----|-----|-----|-----|-----|-----|-----|-----------------|-----|-----|-----|-----|---------------|-----|------|
|                 | Increment |     |     |     |     |     |     |     |     |     | Pulse+Dir Input |     |     |     |     | AB Phase Mode |     |      |
|                 | C60       | C60 | C60 | C60 | C60 | C61 | C61 | C61 | C61 | C61 | C62             | C62 | C62 | C62 | C62 | C63           | C63 | C634 |
|                 | 0         | 2   | 4   | 6   | 8   | 0   | 2   | 4   | 6   | 8   | 0               | 2   | 4   | 6   | 8   | 0             | 2   |      |
| Max.F           | 80K       | 80K | 10K | 10K | 10K |     |     |     |     |     | 80K             | 10K |     |     |     | 80K           | 5K  |      |
| 4-times F       |           |     |     |     |     |     |     |     |     |     |                 |     |     |     |     | 1/4           | 1   |      |
| Count Interrupt | √         | √   | √   | √   | √   |     |     |     |     |     | √               |     |     |     |     | √             |     |      |

|      |   |   |   |   |   |  |  |  |  |  |  |  |  |  |  |   |     |     |  |  |  |  |  |  |   |  |   |  |  |
|------|---|---|---|---|---|--|--|--|--|--|--|--|--|--|--|---|-----|-----|--|--|--|--|--|--|---|--|---|--|--|
| X000 | U |   |   |   |   |  |  |  |  |  |  |  |  |  |  | U |     |     |  |  |  |  |  |  | A |  |   |  |  |
| X001 |   | U |   |   |   |  |  |  |  |  |  |  |  |  |  |   | Dir |     |  |  |  |  |  |  |   |  | B |  |  |
| X002 |   |   |   |   |   |  |  |  |  |  |  |  |  |  |  |   |     |     |  |  |  |  |  |  |   |  |   |  |  |
| X003 |   |   | U |   |   |  |  |  |  |  |  |  |  |  |  |   |     | U   |  |  |  |  |  |  |   |  | A |  |  |
| X004 |   |   |   |   |   |  |  |  |  |  |  |  |  |  |  |   |     | Dir |  |  |  |  |  |  |   |  | B |  |  |
| X005 |   |   |   |   |   |  |  |  |  |  |  |  |  |  |  |   |     |     |  |  |  |  |  |  |   |  |   |  |  |
| X006 |   |   |   | U |   |  |  |  |  |  |  |  |  |  |  |   |     |     |  |  |  |  |  |  |   |  |   |  |  |
| X007 |   |   |   |   | U |  |  |  |  |  |  |  |  |  |  |   |     |     |  |  |  |  |  |  |   |  |   |  |  |
| X010 |   |   |   |   |   |  |  |  |  |  |  |  |  |  |  |   |     |     |  |  |  |  |  |  |   |  |   |  |  |
| X011 |   |   |   |   |   |  |  |  |  |  |  |  |  |  |  |   |     |     |  |  |  |  |  |  |   |  |   |  |  |
| X012 |   |   |   |   |   |  |  |  |  |  |  |  |  |  |  |   |     |     |  |  |  |  |  |  |   |  |   |  |  |

\*1: XC2-16: C600, C602, C620, C630 max frequency is 10 KHz.

\*2: XC2-14: the max frequency is 10 KHz, 80 KHz needs to order.

| XC3-14 PLC      |           |     |     |     |     |     |     |     |     |     |                 |     |     |     |     |               |     |     |  |  |  |  |  |  |  |   |   |  |  |
|-----------------|-----------|-----|-----|-----|-----|-----|-----|-----|-----|-----|-----------------|-----|-----|-----|-----|---------------|-----|-----|--|--|--|--|--|--|--|---|---|--|--|
|                 | Increment |     |     |     |     |     |     |     |     |     | Pulse+Dir Input |     |     |     |     | AB Phase Mode |     |     |  |  |  |  |  |  |  |   |   |  |  |
|                 | C60       | C60 | C60 | C60 | C60 | C61 | C61 | C61 | C61 | C61 | C62             | C62 | C62 | C62 | C62 | C63           | C63 | C63 |  |  |  |  |  |  |  |   |   |  |  |
|                 | 0         | 2   | 4   | 6   | 8   | 0   | 2   | 4   | 6   | 8   | 0               | 2   | 4   | 6   | 8   | 0             | 2   | 4   |  |  |  |  |  |  |  |   |   |  |  |
| *Max.F          | 10K       | 10K | 10K | 10K | 10K |     |     |     |     |     | 10K             | 10K |     |     |     | 5K            | 5K  |     |  |  |  |  |  |  |  |   |   |  |  |
| 4-times F       |           |     |     |     |     |     |     |     |     |     |                 |     |     |     |     | 1             | 1/4 |     |  |  |  |  |  |  |  |   |   |  |  |
| Count Interrupt | √         | √   | √   | √   | √   |     |     |     |     |     |                 |     |     |     |     |               | √   |     |  |  |  |  |  |  |  |   |   |  |  |
| X000            | U         |     |     |     |     |     |     |     |     |     |                 |     |     |     |     | U             |     |     |  |  |  |  |  |  |  | A |   |  |  |
| X001            |           |     |     |     |     |     |     |     |     |     |                 |     |     |     |     |               | Dir |     |  |  |  |  |  |  |  |   | B |  |  |
| X002            |           | U   |     |     |     |     |     |     |     |     |                 |     |     |     |     |               |     |     |  |  |  |  |  |  |  |   |   |  |  |
| X003            |           |     | U   |     |     |     |     |     |     |     |                 |     |     |     |     |               |     |     |  |  |  |  |  |  |  |   |   |  |  |
| X004            |           |     |     |     |     |     |     |     |     |     |                 |     |     |     |     |               |     | Dir |  |  |  |  |  |  |  |   | B |  |  |
| X005            |           |     |     |     | U   |     |     |     |     |     |                 |     |     |     |     |               |     | U   |  |  |  |  |  |  |  |   | A |  |  |
| X006            |           |     |     |     |     | U   |     |     |     |     |                 |     |     |     |     |               |     |     |  |  |  |  |  |  |  |   |   |  |  |

\* C600, C620, C630 can be 80 KHz, 80 KHz, 50 KHz for special order of customer.

| XC3-19AR-E      |           |     |     |     |     |     |     |     |     |     |                 |     |     |     |     |               |     |     |
|-----------------|-----------|-----|-----|-----|-----|-----|-----|-----|-----|-----|-----------------|-----|-----|-----|-----|---------------|-----|-----|
|                 | Increment |     |     |     |     |     |     |     |     |     | Pulse+Dir Input |     |     |     |     | AB Phase Mode |     |     |
|                 | C60       | C60 | C60 | C60 | C60 | C61 | C61 | C61 | C61 | C61 | C62             | C62 | C62 | C62 | C62 | C63           | C63 | C63 |
|                 | 0         | 2   | 4   | 6   | 8   | 0   | 2   | 4   | 6   | 8   | 0               | 2   | 4   | 6   | 8   | 0             | 2   | 4   |
| Max.F           | 10K       | 10K | 10K | 10K |     |     |     |     |     |     | 10K             | 10K |     |     |     | 5K            | 5K  |     |
| 4-times F       |           |     |     |     |     |     |     |     |     |     |                 |     |     |     |     | 1             | 1/4 |     |
| Count Interrupt | √         | √   | √   | √   |     |     |     |     |     |     |                 | √   |     |     |     |               | √   |     |

|      |   |   |   |   |  |  |  |  |  |  |     |     |  |  |  |   |   |  |
|------|---|---|---|---|--|--|--|--|--|--|-----|-----|--|--|--|---|---|--|
| X000 | U |   |   |   |  |  |  |  |  |  | U   |     |  |  |  | A |   |  |
| X001 |   |   |   |   |  |  |  |  |  |  | Dir |     |  |  |  | B |   |  |
| X002 |   | U |   |   |  |  |  |  |  |  |     | U   |  |  |  |   | A |  |
| X003 |   |   |   |   |  |  |  |  |  |  |     | Dir |  |  |  |   | B |  |
| X004 |   |   | U |   |  |  |  |  |  |  |     |     |  |  |  |   |   |  |
| X005 |   |   |   | U |  |  |  |  |  |  |     |     |  |  |  |   |   |  |

| XC3-24, 32, 42 PLC and XC5-48, 60 PLC |           |          |          |          |          |          |          |          |          |          |                 |          |          |          |          |               |          |          |
|---------------------------------------|-----------|----------|----------|----------|----------|----------|----------|----------|----------|----------|-----------------|----------|----------|----------|----------|---------------|----------|----------|
|                                       | Increment |          |          |          |          |          |          |          |          |          | Pulse+Dir Input |          |          |          |          | AB Phase Mode |          |          |
|                                       | C60<br>0  | C60<br>2 | C60<br>4 | C60<br>6 | C60<br>8 | C61<br>0 | C61<br>2 | C61<br>4 | C61<br>6 | C61<br>8 | C62<br>0        | C62<br>2 | C62<br>4 | C62<br>6 | C62<br>8 | C63<br>0      | C63<br>2 | C63<br>4 |
| Max.F                                 | 80K       | 80K      | 10K      | 10K      | 10K      | 10K      |          |          |          |          | 80K             | 10K      | 10K      |          |          | 80K           | 5K       | 5K       |
| 4-times F                             |           |          |          |          |          |          |          |          |          |          |                 |          |          |          |          | 1/4           | 1        | 4        |
| Count Interrupt                       | √         | √        | √        | √        | √        | √        |          |          |          |          | √               |          |          |          | √        |               |          |          |
| X000                                  | U         |          |          |          |          |          |          |          |          |          | U               |          |          |          |          | A             |          |          |
| X001                                  |           | U        |          |          |          |          |          |          |          |          | Dir             |          |          |          |          | B             |          |          |
| X002                                  |           |          |          |          |          |          |          |          |          |          |                 |          |          |          |          |               |          |          |
| X003                                  |           |          | U        |          |          |          |          |          |          |          |                 | U        |          |          |          |               | A        |          |
| X004                                  |           |          |          |          |          |          |          |          |          |          |                 | Dir      |          |          |          |               | B        |          |
| X005                                  |           |          |          |          |          |          |          |          |          |          |                 |          |          |          |          |               |          |          |
| X006                                  |           |          |          | U        |          |          |          |          |          |          |                 |          | U        |          |          |               |          | A        |
| X007                                  |           |          |          |          |          |          |          |          |          |          |                 |          | Dir      |          |          |               |          | B        |
| X010                                  |           |          |          |          |          |          |          |          |          |          |                 |          |          |          |          |               |          |          |
| X011                                  |           |          |          |          | U        |          |          |          |          |          |                 |          |          |          |          |               |          |          |
| X012                                  |           |          |          |          |          | U        |          |          |          |          |                 |          |          |          |          |               |          |          |

\*XC5-48, XC5-60: the max frequency of C622, C632 is 80 KHz, 50 KHz.

| XC3-48, 60 PLC  |           |          |          |          |          |          |          |          |          |          |                 |          |          |          |          |               |          |          |
|-----------------|-----------|----------|----------|----------|----------|----------|----------|----------|----------|----------|-----------------|----------|----------|----------|----------|---------------|----------|----------|
|                 | Increment |          |          |          |          |          |          |          |          |          | Pulse+Dir Input |          |          |          |          | AB Phase Mode |          |          |
|                 | C60<br>0  | C60<br>2 | C60<br>4 | C60<br>6 | C60<br>8 | C61<br>0 | C61<br>2 | C61<br>4 | C61<br>6 | C61<br>8 | C62<br>0        | C62<br>2 | C62<br>4 | C62<br>6 | C62<br>8 | C63<br>0      | C63<br>2 | C63<br>4 |
| Max.F           | 80K       | 80K      | 10K      | 10K      |          |          |          |          |          |          | 80K             | 80K      |          |          |          | 50K           | 50K      |          |
| 4-times F       |           |          |          |          |          |          |          |          |          |          |                 |          |          |          |          | 1             | 1/4      |          |
| Count Interrupt | √         | √        | √        | √        |          |          |          |          |          |          |                 | √        |          |          |          |               | √        |          |
| X000            | U         |          |          |          |          |          |          |          |          |          | U               |          |          |          |          | A             |          |          |

|      |  |   |   |   |  |  |  |  |  |  |  |  |  |  |     |     |  |  |  |   |   |  |
|------|--|---|---|---|--|--|--|--|--|--|--|--|--|--|-----|-----|--|--|--|---|---|--|
| X001 |  |   |   |   |  |  |  |  |  |  |  |  |  |  | Dir |     |  |  |  | B |   |  |
| X002 |  | U |   |   |  |  |  |  |  |  |  |  |  |  |     | U   |  |  |  |   | A |  |
| X003 |  |   |   |   |  |  |  |  |  |  |  |  |  |  |     | Dir |  |  |  |   | B |  |
| X004 |  |   | U |   |  |  |  |  |  |  |  |  |  |  |     |     |  |  |  |   |   |  |
| X005 |  |   |   | U |  |  |  |  |  |  |  |  |  |  |     |     |  |  |  |   |   |  |

| XC5-24/32 PLC, XCM-24/32 PLC |           |     |     |     |     |     |     |     |     |     |                 |     |     |     |     |               |     |     |  |  |  |
|------------------------------|-----------|-----|-----|-----|-----|-----|-----|-----|-----|-----|-----------------|-----|-----|-----|-----|---------------|-----|-----|--|--|--|
|                              | Increment |     |     |     |     |     |     |     |     |     | Pulse+Dir Input |     |     |     |     | AB Phase Mode |     |     |  |  |  |
|                              | C60       | C60 | C60 | C60 | C60 | C61 | C61 | C61 | C61 | C61 | C62             | C62 | C62 | C62 | C62 | C63           | C63 | C63 |  |  |  |
|                              | 0         | 2   | 4   | 6   | 8   | 0   | 2   | 4   | 6   | 8   | 0               | 2   | 4   | 6   | 8   | 0             | 2   | 4   |  |  |  |
| Max.F                        | 80K       | 10K |     |     |     |     |     |     |     |     | 80K             |     |     |     |     | 50K           |     |     |  |  |  |
| 4-times F                    |           |     |     |     |     |     |     |     |     |     |                 |     |     |     |     | 1/4           |     |     |  |  |  |
| Count Interrupt              | √         | √   |     |     |     |     |     |     |     |     | √               |     |     |     |     | √             |     |     |  |  |  |
| X000                         | U         |     |     |     |     |     |     |     |     |     | U               |     |     |     |     | A             |     |     |  |  |  |
| X001                         |           |     |     |     |     |     |     |     |     |     | Dir             |     |     |     |     | B             |     |     |  |  |  |
| X002                         |           |     |     |     |     |     |     |     |     |     |                 |     |     |     |     |               |     |     |  |  |  |
| X003                         |           | U   |     |     |     |     |     |     |     |     |                 |     |     |     |     |               |     |     |  |  |  |
| X004                         |           |     |     |     |     |     |     |     |     |     |                 |     |     |     |     |               |     |     |  |  |  |
| X005                         |           |     |     |     |     |     |     |     |     |     |                 |     |     |     |     |               |     |     |  |  |  |
| X006                         |           |     |     |     |     |     |     |     |     |     |                 |     |     |     |     |               |     |     |  |  |  |

| XCM-24/32T3-E   |           |     |     |     |     |     |     |     |     |     |                 |     |     |     |     |               |     |     |  |  |  |
|-----------------|-----------|-----|-----|-----|-----|-----|-----|-----|-----|-----|-----------------|-----|-----|-----|-----|---------------|-----|-----|--|--|--|
|                 | Increment |     |     |     |     |     |     |     |     |     | Pulse+Dir Input |     |     |     |     | AB Phase Mode |     |     |  |  |  |
|                 | C60       | C60 | C60 | C60 | C60 | C61 | C61 | C61 | C61 | C61 | C62             | C62 | C62 | C62 | C62 | C63           | C63 | C63 |  |  |  |
|                 | 0         | 2   | 4   | 6   | 8   | 0   | 2   | 4   | 6   | 8   | 0               | 2   | 4   | 6   | 8   | 0             | 2   | 4   |  |  |  |
| Max.F           | 80K       | 10K | 10K | 10K |     |     |     |     |     |     | 80K             | 10K |     |     |     | 50K           | 10K |     |  |  |  |
| 4-times F       |           |     |     |     |     |     |     |     |     |     |                 |     |     |     |     | 1/4           | 1   |     |  |  |  |
| Count Interrupt | √         | √   | √   | √   |     |     |     |     |     |     | √               |     |     |     |     | √             |     |     |  |  |  |
| X000            | U         |     |     |     |     |     |     |     |     |     | U               |     |     |     |     | A             |     |     |  |  |  |
| X001            |           |     |     |     |     |     |     |     |     |     | Dir             |     |     |     |     | B             |     |     |  |  |  |
| X002            |           |     |     |     |     |     |     |     |     |     |                 |     |     |     |     |               |     |     |  |  |  |
| X003            |           | U   |     |     |     |     |     |     |     |     |                 | U   |     |     |     |               | A   |     |  |  |  |
| X004            |           |     |     |     |     |     |     |     |     |     |                 | Dir |     |     |     |               | B   |     |  |  |  |
| X005            |           |     |     |     |     |     |     |     |     |     |                 |     |     |     |     |               |     |     |  |  |  |
| X006            |           |     | U   |     |     |     |     |     |     |     |                 |     |     |     |     |               |     |     |  |  |  |
| X007            |           |     |     | U   |     |     |     |     |     |     |                 |     |     |     |     |               |     |     |  |  |  |

\* X7 cannot be used together with Y0.

| XCM-60T-E       |           |     |     |     |     |     |     |     |     |     |                 |     |     |     |     |               |     |     |
|-----------------|-----------|-----|-----|-----|-----|-----|-----|-----|-----|-----|-----------------|-----|-----|-----|-----|---------------|-----|-----|
|                 | Increment |     |     |     |     |     |     |     |     |     | Pulse+Dir Input |     |     |     |     | AB Phase Mode |     |     |
|                 | C60       | C60 | C60 | C60 | C60 | C61 | C61 | C61 | C61 | C61 | C62             | C62 | C62 | C62 | C62 | C63           | C63 | C63 |
|                 | 0         | 2   | 4   | 6   | 8   | 0   | 2   | 4   | 6   | 8   | 0               | 2   | 4   | 6   | 8   | 0             | 2   | 4   |
| Max.F           | 80K       | 10K | 10K | 10K |     |     |     |     |     |     | 80K             |     |     |     |     | 50K           | 10K | 10K |
| 4-times F       |           |     |     |     |     |     |     |     |     |     |                 |     |     |     |     | 1/4           | 1/4 | 1/4 |
| Count Interrupt | √         | √   | √   | √   |     |     |     |     |     |     | √               |     |     |     |     | √             | √   | √   |
| X000            | U         |     |     |     |     |     |     |     |     |     | U               |     |     |     |     | A             |     |     |
| X001            |           | U   |     |     |     |     |     |     |     |     | Dir             |     |     |     |     | B             |     |     |
| X002            |           |     |     |     |     |     |     |     |     |     |                 |     |     |     |     |               |     |     |
| X003            |           |     |     |     |     |     |     |     |     |     |                 |     |     |     |     |               |     |     |
| X004            |           |     |     |     |     |     |     |     |     |     |                 |     |     |     |     |               |     |     |
| X005            |           |     |     |     |     |     |     |     |     |     |                 |     |     |     |     |               |     |     |
| X006            |           |     | U   |     |     |     |     |     |     |     |                 |     |     |     |     |               | A   |     |
| X007            |           |     |     |     |     |     |     |     |     |     |                 |     |     |     |     |               | B   |     |
| X010            |           |     |     | U   |     |     |     |     |     |     |                 |     |     |     |     |               |     | A   |
| X011            |           |     |     |     |     |     |     |     |     |     |                 |     |     |     |     |               |     | B   |

| XCC-24/32T-E    |           |     |     |     |     |     |     |     |     |     |               |     |     |     |     |  |  |  |
|-----------------|-----------|-----|-----|-----|-----|-----|-----|-----|-----|-----|---------------|-----|-----|-----|-----|--|--|--|
|                 | Increment |     |     |     |     |     |     |     |     |     | AB Phase Mode |     |     |     |     |  |  |  |
|                 | C60       | C60 | C60 | C60 | C60 | C61 | C61 | C61 | C61 | C61 | C63           | C63 | C63 | C63 | C63 |  |  |  |
|                 | 0         | 2   | 4   | 6   | 8   | 0   | 2   | 4   | 6   | 8   | 0             | 2   | 4   | 6   | 8   |  |  |  |
| Max.F           | 80K       | 80K | 80K | 10K | 10K |     |     |     |     |     | 50K           | 50K | 50K | 10K | 10K |  |  |  |
| 4-times F       |           |     |     |     |     |     |     |     |     |     | 1/4           | 1/4 | 1/4 | 1/4 | 1/4 |  |  |  |
| Count Interrupt | √         | √   | √   | √   | √   |     |     |     |     |     | √             | √   | √   | √   | √   |  |  |  |
| X000            | U         |     |     |     |     |     |     |     |     |     | A             |     |     |     |     |  |  |  |
| X001            |           |     |     |     |     |     |     |     |     |     | B             |     |     |     |     |  |  |  |
| X002            |           | U   |     |     |     |     |     |     |     |     |               | A   |     |     |     |  |  |  |
| X003            |           |     |     |     |     |     |     |     |     |     |               | B   |     |     |     |  |  |  |
| X004            |           |     | U   |     |     |     |     |     |     |     |               |     | A   |     |     |  |  |  |
| X005            |           |     |     |     |     |     |     |     |     |     |               |     | B   |     |     |  |  |  |
| X006            |           |     |     | U   |     |     |     |     |     |     |               |     |     | A   |     |  |  |  |
| X007            |           |     |     |     |     |     |     |     |     |     |               |     |     | B   |     |  |  |  |
| X010            |           |     |     |     | U   |     |     |     |     |     |               |     |     |     | A   |  |  |  |
| X011            |           |     |     |     |     |     |     |     |     |     |               |     |     |     | B   |  |  |  |

**5-6. Read/Write HSC value**

All high speed counters support read instruction [HSCR] and write instruction [HSCW], but users need to use hardware V3.1c and above.

**5-6-1. Read HSC value [HSCR]**

1、Instruction Summary

Read HSC value to the specified register;

| Read from HSC [HSCR]/ write to HSC [HSCW] |                                      |                        |                 |
|---|--------------------------------------|------------------------|-----------------|
| 16 bits<br>Instruction                    | -                                    | 32 bits<br>Instruction | HSCR            |
| Execution condition                       | Normally ON/OFF, rising/falling edge | Suitable models        | XC2、XC3、XC5、XCM |
| Hardware requirement                      | V3.1c and above                      | Software requirement   | -               |

2、Operands

| Operands | Function                          | Type         |
|----------|-----------------------------------|--------------|
| S        | Specify HSC code                  | 32 bits, BIN |
| D        | Specify the read/written register | 32 bits, BIN |

3、Suitable Soft Components

| word | operands | system |    |    |    |    |    |    |    | constant | module |    |    |
|------|----------|--------|----|----|----|----|----|----|----|----------|--------|----|----|
|      |          | D      | FD | ED | TD | CD | DX | DY | DM | DS       | K/H    | ID | QD |
| S    |          |        |    |    |    | •  |    |    |    |          |        |    |    |
| D    | •        |        |    |    |    |    |    |    |    |          |        |    |    |

**FUNCTIONS AND ACTIONS**

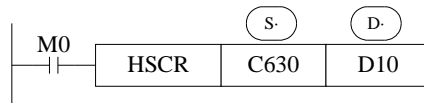

- When the activate condition is true, read the HSC value in C630 (DWORD) into D10 (DWORD)
- Instruction HSCR read the HSC value into the specified register, improve HSC value's precision.
- Note: For hardware version larger than 3.1, please use HSCR to move the high speed counter value to the register. DMOV instruction cannot be used.



**FUNCTIONS AND ACTIONS**

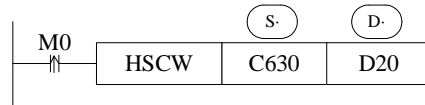

- When the activate condition is true, write the value in D20 (DWORD) into C630 (DWORD), the original value is replaced;
- We suggest the users to apply high speed counter only with HSCR and HSCW, not with other instructions like DMOV, LD>, DMUL etc. and users must run after converting HSC to be other registers.

Sample program:



**5-7. HSC Reset Mode**

Reset HSC via software:

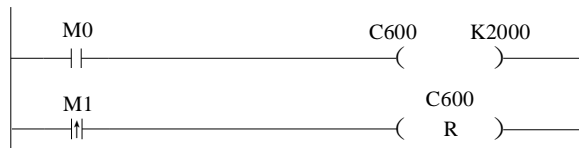

In the above graph, when M0 is ON, C600 starts to count the input pulse on X0; when M1 changes from OFF to be ON, reset C600, and clear the count value

**5-8. AB Phase counter multiplication setting**

About AB phase counter, modify the frequency multiplication value via setting FLASH data register FD8241, FD8242, FD8243. If the value is 1, it is 1-time frequency, if it is 4; it is 4-time frequency.

| Register | Function                         | Set Value | Meaning          |
|----------|----------------------------------|-----------|------------------|
| FD8241   | Frequency multiplication of C630 | 1         | 1-time frequency |
|          |                                  | 4         | 4-time frequency |
| FD8242   | Frequency multiplication of C632 | 1         | 1-time frequency |
|          |                                  | 4         | 4-time frequency |
| FD8243   | Frequency multiplication of C634 | 1         | 1-time frequency |
|          |                                  | 4         | 4-time frequency |

**5-9. HSC Example**

Below, we take XC3-60 PLC as an example to introduce HSC programming method

Incremental Mode

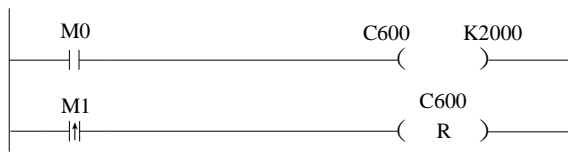

- When M0 is ON, C600 starts the HSC with the OFF→ON of X000;
- When comes the rising edge of M1, reset HSC C600

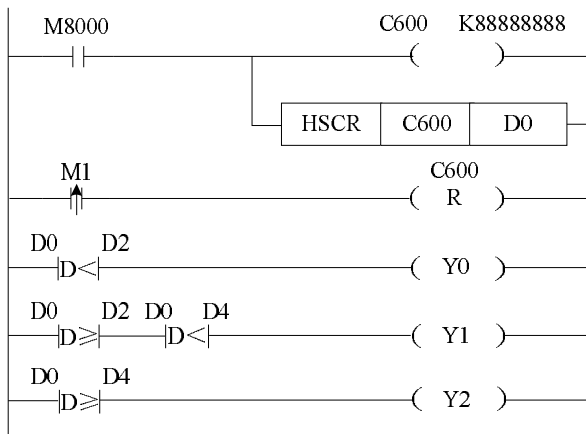

- When normally ON coil M8000 is ON, set the value of C600, the set value is K888888888, read the HSC value (DWORD) into data register D0 (DWORD).
- If the value in C600 is smaller than value in D2, set the output coil Y0 ON; If the value in C600 equals or be larger than value in D2, and smaller than value in D4, set the output coil Y1 ON; If the value in C600 equals or be larger than value in D4, set the output coil Y2 ON;
- When the rising edge of M1 is coming, reset HSC C600 and stop counting.

Pulse+Direction Mode

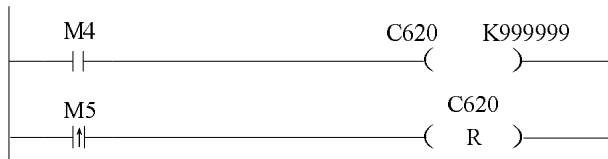

- When M4 is ON, C620 starts the HSC with the OFF→ON of X000; Judge the count direction according to the input X001 status (OFF or ON). If X001 is OFF, it's increment count; if X001 is ON, it's decrement count;
- When the rising edge of M5 is coming, reset HSC C620 and stop counting.

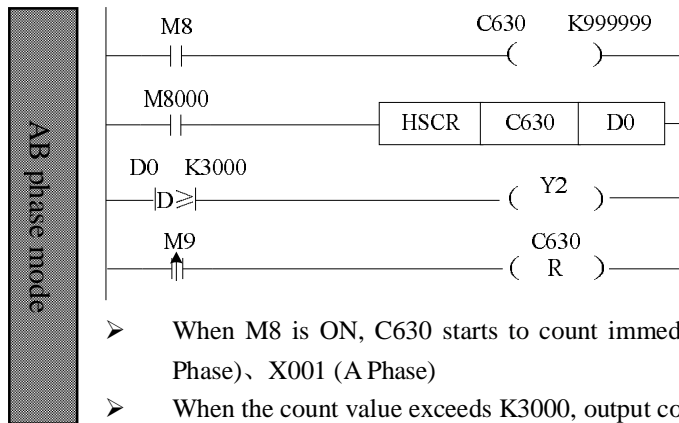

- When M8 is ON, C630 starts to count immediately. Count input via X000 (B Phase)、X001 (A Phase)
- When the count value exceeds K3000, output coil Y2 is ON;
- When comes the rising edge of M9, reset HSC C630

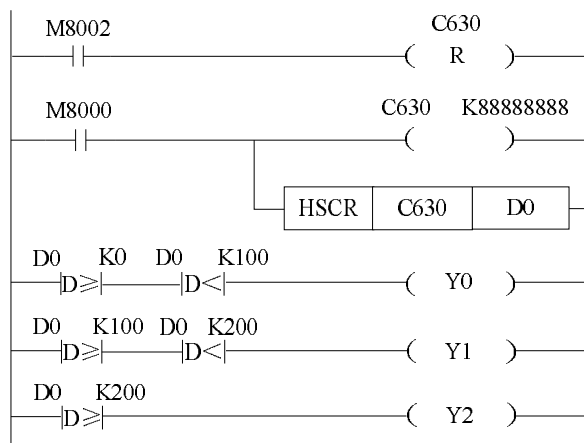

- When the rising edge of initial positive pulse coil M8002 comes, i.e. each scan cycle starts, HSC C630 reset and clear the count value.
- When set coil M8000 ON, C630 starts to count, the count value is set to be K88888888.
- If the count value is greater than K0 but smaller than K100, the output coil Y0 set ON; If the count value is greater than K100 but smaller than K200, the output coil Y1 set ON; If the count value is greater than K200, the output coil Y2 set ON;

## 5-10. HSC Interruption

To XC series PLC, each HSC channels has 24 segments 32-bit pre-set value. When the HSC difference value equals the correspond 24-segment pre-set value, then interruption occurs according to the interruption tag;

To use this function, please use hardware V3.1c or above;

### 5-10-1. Instruction Description

(For the program about interruption, please refer chapter 5-10-4)

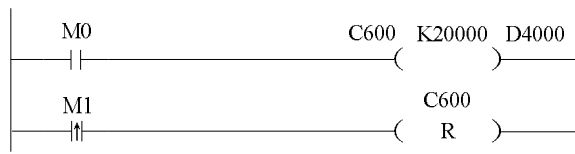

```
LD    M0                //HSC activates condition M0 (interruption count
                        condition)
OUT   C600  K20000  D4000  //HSC value and set the start ID of 24-segment
LDP   M1                //activate condition of reset
RST   C600              //HSC and 24-segment reset (interruption
                        reset)
```

As shown in the above graph, data register D4000 is the start ID of 24-segment pre-set value area. Behind it, save each pre-set value in DWORD form. Please pay attention when using HSC:

- If certain pre-set value is 0, it means count interruption end at this segment;
- Set the interruption pre-set value but not write the correspond interruption program is not allowed;
- 24-segment interruption of HSC occurs in order. If the first segment interruption doesn't happen, then the second segment interruption will not happen;
- 24-segment pre-set value can be specified to be relative value or absolute value. Meantime, users can specify the value to be loop or not. But the loop mode can't be used together with absolute value. (Please refer to special coil M8190~M8209, M8270~M8287).

### 5-10-2. Interruption tags to HSC

In the below table, we list each counter's 24-segment pre-set value to its interruption tag. I.e.: 24-segment pre-set value of counter C600 correspond with the interruption pointer: I1001, I1002, and I1003 ...I1024.

| Increment mode |                  | pulse + direction mode |                  | AB phase mode |                  |
|----------------|------------------|------------------------|------------------|---------------|------------------|
| Counter        | Interruption tag | Counter                | Interruption tag | Counter       | Interruption tag |
| C600           | I1001~I1024      | C620                   | I2001~I2024      | C630          | I2501~I2524      |
| C602           | I1101~I1124      | C622                   | I2101~I2124      | C632          | I2601~I2624      |
| C604           | I1201~I1224      | C624                   | I2201~I2224      | C634          | I2701~I2724      |
| C606           | I1301~I1324      | C626                   | I2301~I2324      | C636          | I2801~I2824      |
| C608           | I1401~I1424      | C628                   | I2401~I2424      | C638          | I2901~I2924      |
| C610           | I1501~I1524      |                        |                  |               |                  |
| C612           | I1601~I1624      |                        |                  |               |                  |
| C614           | I1701~I1724      |                        |                  |               |                  |
| C616           | I1801~I1824      |                        |                  |               |                  |
| C618           | I1901~I1924      |                        |                  |               |                  |

### Define the present value

HSC 24-segment pre-set value is the difference value, the count value equals the counter's current value plus the preset value, generate the interruption. N interruption tags correspond with N interruption preset values. The (N+1) preset value is 0;

E.g. 1, the current value is C630 is 0, the first preset value is 10000, the preset value in segment 2 is  $-5000$ , and the present value in segment 3 is 20000. When start to count, the counter's current value is 10000, generate first interruption I2501; When start to count, the counter's current value is 5000, generate first interruption I2502; When start to count, the counter's current value is 25000, generate first interruption I2503.

See graph below:

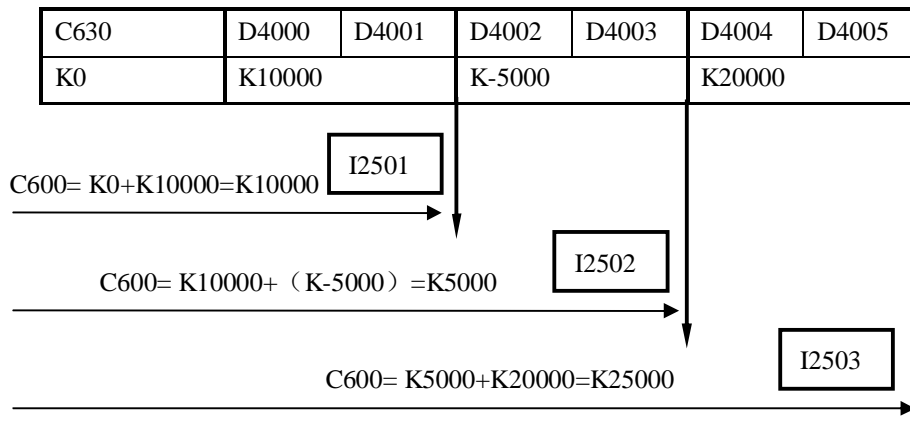

E.g. 2, the current value is C630 is 10000, the first preset value is 10000, the preset value in segment 2 is 5000, and the preset value in segment 3 is 20000. When start to count, the counter's current value is 20000, generate first interruption I2501; When start to count, the counter's current value is 25000, generate first interruption I2502; When start to count, the counter's current value is 45000, generate first interruption I2503.

See graph below:

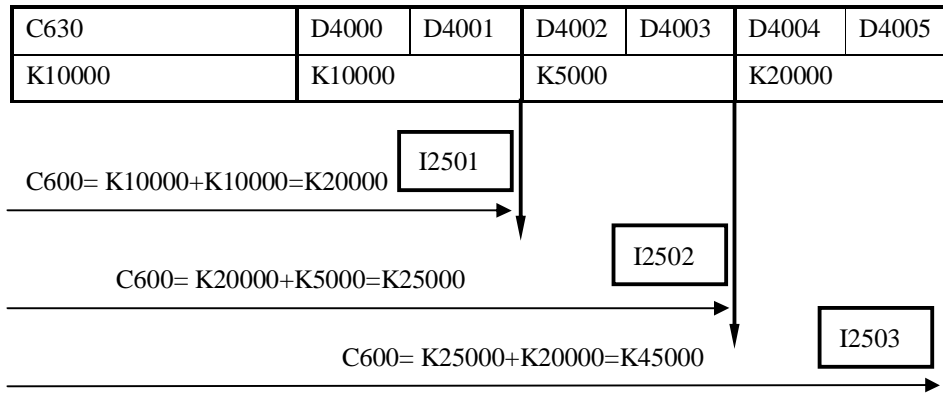

### 5-10-3. Loop mode of HSC Interruption

Mode 1: Single loop (normal mode)

Not happen after HSC interruption ends. The conditions below can re-start the interruption:

- reset the HSC
- Reboot the HSC activate condition

Mode 2: Continuous loop

Restart after HSC interruption ends. This mode is especially suitable for the following application:

- continuous back-forth movement
- Generate cycle interruption according to the defined pulse

Via setting the special auxiliary relays, users can set the HSC interruption to be unicycle mode or continuous loop mode. The loop mode is only suitable with the relative count. The detailed assignment is show below:

| ID    | HSC ID                                   | Setting   |
|-------|--|---|
| M8270 | 24 segments HSC interruption loop (C600) | OFF: single loop mode<br>ON: continuous loop mode |
| M8271 | 24 segments HSC interruption loop (C602) |   |
| M8272 | 24 segments HSC interruption loop (C604) |   |
| M8273 | 24 segments HSC interruption loop (C606) |   |
| M8274 | 24 segments HSC interruption loop (C608) |   |
| M8275 | 24 segments HSC interruption loop (C610) |   |
| M8276 | 24 segments HSC interruption loop (C612) |   |
| M8277 | 24 segments HSC interruption loop (C614) |   |
| M8278 | 24 segments HSC interruption loop (C616) |   |
| M8279 | 24 segments HSC interruption loop (C618) |   |
| M8280 | 24 segments HSC interruption loop (C620) |   |

|       |  |
|-------|--|
| M8281 | 24 segments HSC interruption loop (C622) |
| M8282 | 24 segments HSC interruption loop (C624) |
| M8283 | 24 segments HSC interruption loop (C626) |
| M8284 | 24 segments HSC interruption loop (C628) |
| M8285 | 24 segments HSC interruption loop (C630) |
| M8286 | 24 segments HSC interruption loop (C632) |
| M8287 | 24 segments HSC interruption loop (C634) |

**5-10-4. Example of HSC Interruption**

**E.g.1:** when M0 is ON, C630 starts counting from D4000. When it reaches the present value, the interruption is produced. When the rising edge of M1 is coming, clear the C630.

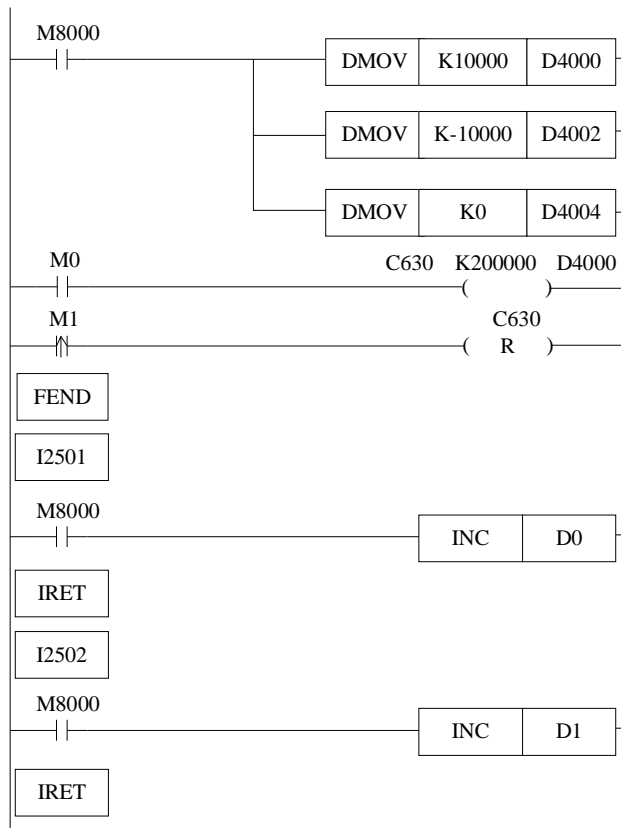

E.g.2: Application on knit-weaving machine (continuous loop mode)

The system theory is shown as below: Control the inverter via PLC, thereby control the motor. Meantime, via the feedback signal from encoder, control the knit-weaving machine and realize the precise position.

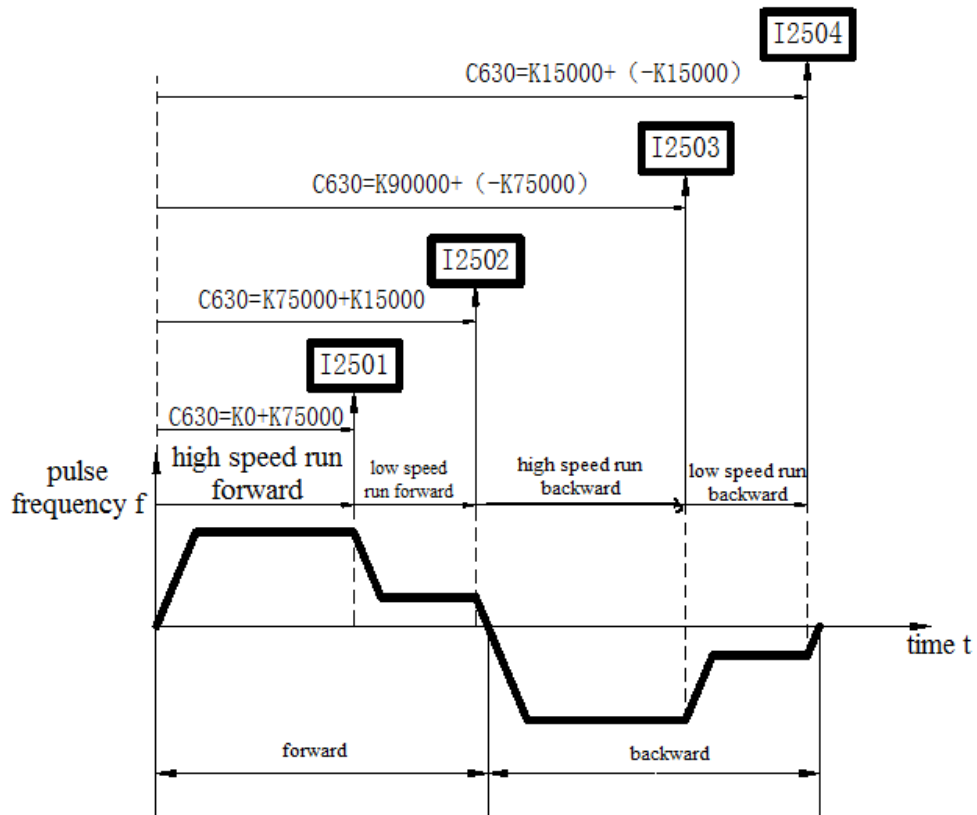
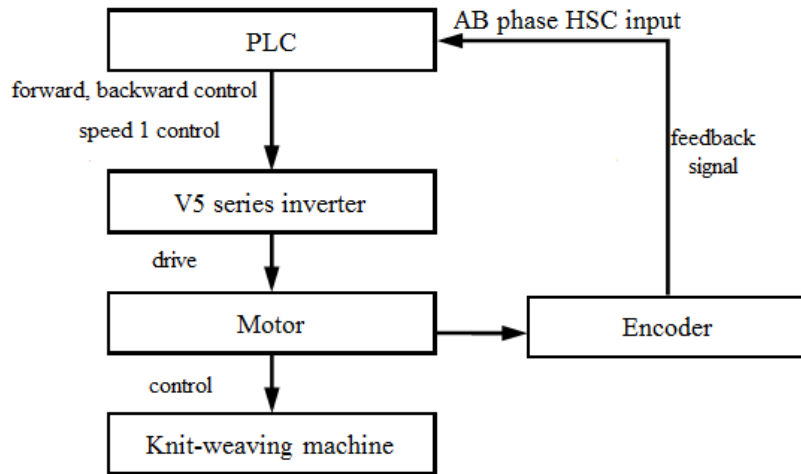

Below is PLC program: Y2 represents forward output signal; Y3 represents backward output signal; Y4 represents output signal of speed 1; C340: Back-forth time's accumulation counter; C630: AB phase HSC;

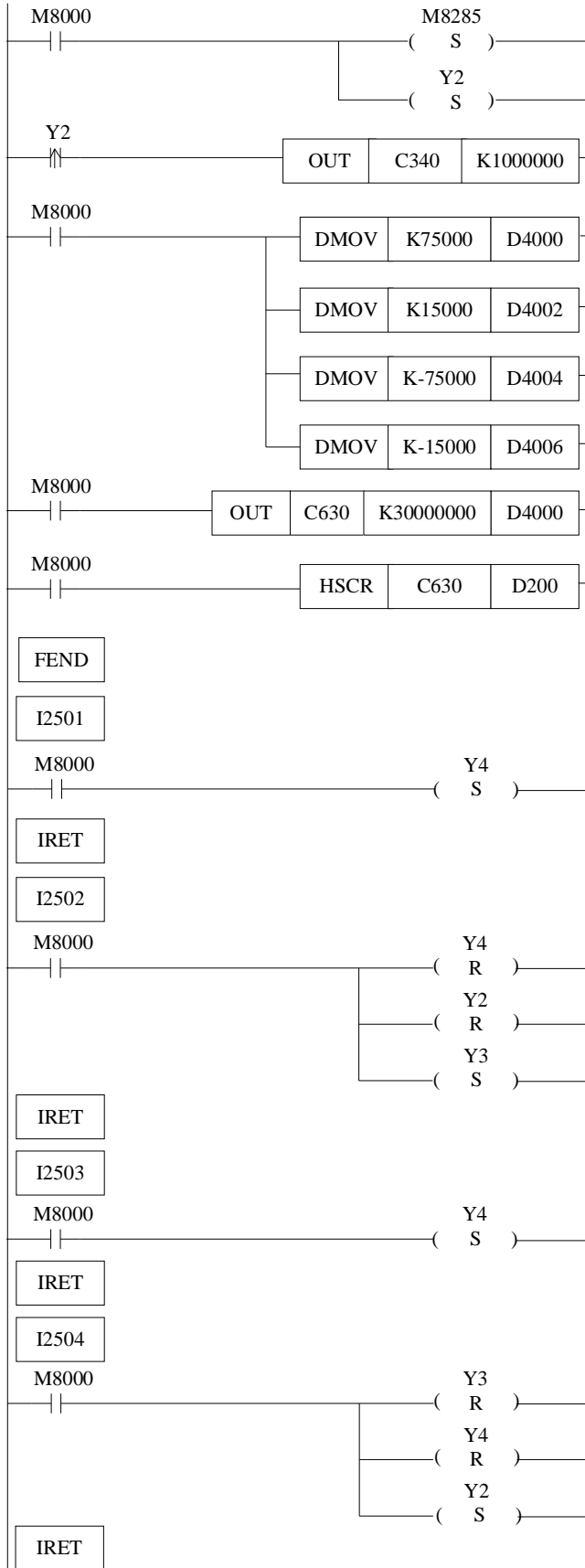

## Instruction List Form:

```

LD M8002 //M8002 is initial positive pulse coil
SET M8285 //special auxiliary relay set ON, to enable C630
continuous loop
SET Y2 //set output coil Y2 (i.e. Start run forth)
LDP Y2 //knit-weaving machine back-forth times counter's activate condition Y2 (forth rising
edge activate)
OUT C340 K1000000 //counter C340 starts to count
LD M8000 //M8000 is normally ON coil
DMOV K75000 D4000 //set segment-1 ID D4000 to be K75000,
DMOV K15000 D4002 //set segment-2 D4002 to be K15000,
DMOV K-75000 D4004 //set segment-3 D4004 to be K-75000,
DMOV K-15000 D4006 //set segment-4 D4004 to be K-15000,
LD M8000 //M8000 is normally ON coil
OUT C630 K30000000 D4000 //HSC and start ID of 24-segment
LD M8000 //M8000 is normally ON coil
HSCR C630 D200 //read the HSC value of C630 to D200
FEND //main program end
I2501 //interruption tag of segment 1
LD M8000 //M8000 is normally ON coil
SET Y4 //output coil Y4 set (low-speed run with speed 1)
IRET //interruption return tag
I2502 ///interruption tag of segment 2
LD M8000 //M8000 is normally ON coil
RST Y4 //output coil Y4 reset (low-speed run stop)
RST Y2 //output coil Y2 reset (run forward stops)
SET Y3 //output coil Y3 set (back running)
IRET //interruption return tag
I2503 ///interruption tag of segment 3
LD M8000 //M8000 is normally ON coil
SET Y4 //output coil Y4 set (low-speed run with speed 1)
IRET //interruption return tag
I2504 ///interruption tag of segment 4
LD M8000 //M8000 is normally ON coil
RST Y3 //output coil Y3 reset (back running stop)
RST Y4 //output coil Y4 reset (low-speed run stop)
SET Y2 //output coil Y2 set (run forward)
IRET //interruption return tag

```

# 6 PULSE OUTPUT

---

In this chapter we will tell the pulse function of XC series PLC. The content includes pulse output instructions, input/output wiring, notes, and relate coils and registers etc.

6-1. Functions Summary

6-2. Pulse Output Types and Instructions







6-3. Output Wiring

6-4. Notes

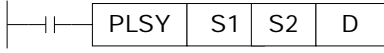
6-5. Sample Programs

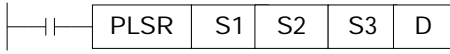
6-6. Coils and Registers Relate To Pulse Output

## Pulse Output Instructions List

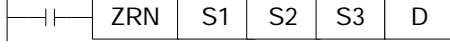
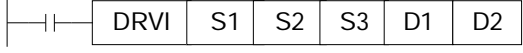
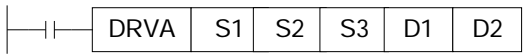
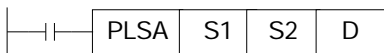
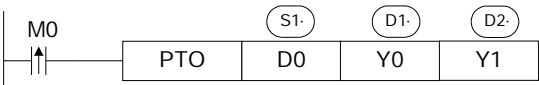
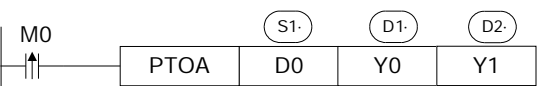
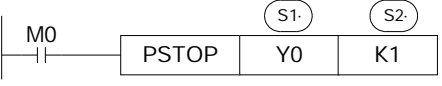
| Mnemonic            | Function  | Circuit And Soft Device  | Chapter |
|---------------------|---|--|---------|
| <b>PULSE OUTPUT</b> |   |  |         |
| PLSY                | Unidirectional pulse output without ACC/DEC time change |    | 6-2-1   |
| PLSF                | Variable frequency pulse output                         |     | 6-2-2   |
| PLSR                | Ration pulse output with ACC/DEC speed                  |    | 6-2-3   |
| PLSNEXT/<br>PLSNT   | Pulse Section Switch                                    |     | 6-2-4   |
| STOP                | Pulse Stop  |     | 6-2-5   |
| PLSMV               | Refresh Pulse Nr. immediately                           |    | 6-2-6   |
| ZRN                 | Original Return   |  | 6-2-7   |
| DRVI                | Relative Position Control                               |  | 6-2-8   |
| DRVA                | Absolute Position Control                               |  | 6-2-9   |
| PLSA                | Absolute Position multi-section pulse control           |  | 6-2-10  |
| PTO                 | Relative position multi-section pulse control           |  | 6-2-11  |
| PTOA                | Absolute position multi-section pulse control           |  | 6-2-12  |
| PSTOP               | Pulse stop  |  | 6-2-13  |

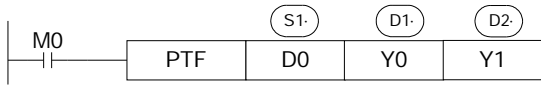
|     |  |  |        |
|-----|--|--|--------|
| PTF | Variable frequency single-section pulse output |  | 6-2-14 |
|-----|--|--|--------|

## 6-1. Functions Summary

Generally, XC3 and XC5 series PLC are equipped with 2CH pulse output function. Via different instructions, users can realize unidirectional pulse output without ACC/DEC speed; unidirectional pulse output with ACC/DEC speed; multi-segments, positive/negative output etc., the output frequency can reach 200K Hz.

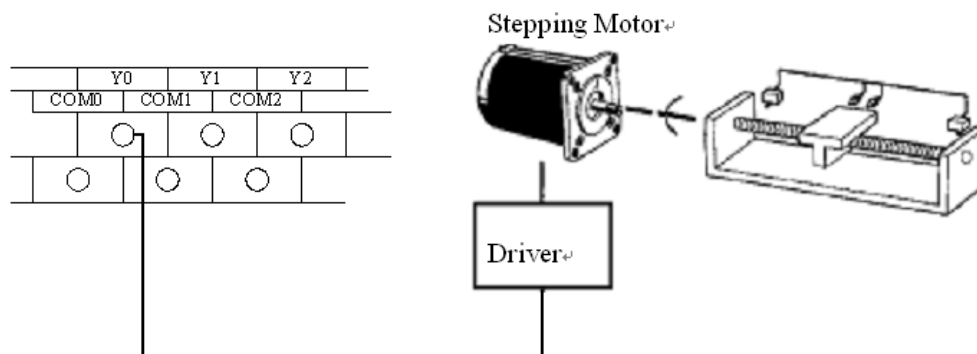

※1: To use pulse output, please choose PLC with transistor output, like XC3-14T-E or XC3-60RT-E etc.

※2: XC5 series 32I/O PLC has 4CH (Y0, Y1, Y2, Y3) pulse output function.

※3: XCM series 32/24 have 4 CH pulse output; XCC series has 5 CH pulse output; XCM-60 has 10 CH pulse output.

※4: Pulse output terminal Y1 cannot be used together with expansion BD.

## 6-2. Pulse Output Types and Instructions

### 6-2-1. Unidirectional ratiion pulse output without ACC/DEC time change [PLSY]

#### 1、 Instruction Summary

Instruction to generate ratiion pulse with the specified frequency;

| Unidirectional ratiion pulse output without ACC/DEC time change [PLSY] |                      |                       |                         |
|--|----------------------|-----------------------|-------------------------|
| 16 bits instruction  | PLSY                 | 32 bits instruction   | DPLSY                   |
| Execution condition  | Normally ON/OFF coil | Suitable models       | XC2, XC3, XC5, XCM, XCC |
| Hardware requirement   | -                    | Software requirements | -                       |

#### 2、 Operands

| Operands | Function                                     | Type                  |
|----------|--|-----------------------|
| S1       | Specify the frequency's value or register ID | 16 bits/32 bits, BIN  |
| S2       | Specify the pulse number or register's ID    | 16 bits /32 bits, BIN |
| D        | Specify the pulse output port                | bit                   |

#### 3、 Suitable soft components

| Word | operands | system |    |    |    |    |    |    |    | constant | module |    |    |
|------|----------|--------|----|----|----|----|----|----|----|----------|--------|----|----|
|      |          | D      | FD | ED | TD | CD | DX | DY | DM | DS       | K/H    | ID | QD |
|      | S1       | •      | •  |    | •  | •  |    |    |    |          | •      |    |    |
|      | S2       | •      | •  |    | •  | •  |    |    |    |          | •      |    |    |

| Bit | operands | system |   |   |   |   |   |     |
|-----|----------|--------|---|---|---|---|---|-----|
|     |          | X      | Y | M | S | T | C | Dnm |
|     | D        |        | • |   |   |   |   |     |

## Functions and Actions

《16 bits instruction》

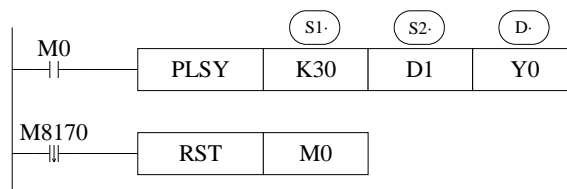

- Frequency Range: 0~32767Hz;
- Pulse Quantity Range: 0~K32767;

- Pulse output from Y000 or Y001 only;
- When M0 is ON, PLSY instruction output 30Hz pulse at Y0, the pulse number is decided by D1, M8170 is set ON only when sending the pulse. When the output pulse number reaches the set value, stop sending the pulse, M8170 is set to be OFF, reset M0;

《32 bits instruction》

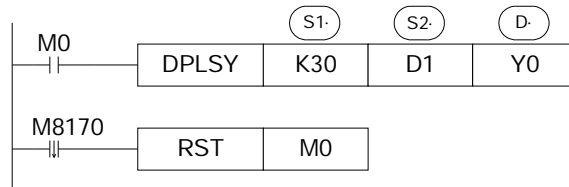

- Frequency Range: 0~200KHz
- Pulse Quantity Range: 0~K2147483647
- Pulse output from Y000 or Y001 only;
- When M0 is ON, DPLSY instruction output 30Hz pulse at Y0, the pulse number is decided by D2D1, M8170 is set ON only when sending the pulse. When the output pulse number reaches the set value, stop sending the pulse, M8170 is set to be OFF, reset M0;

### Output Mode

《continuous or limited pulse number》

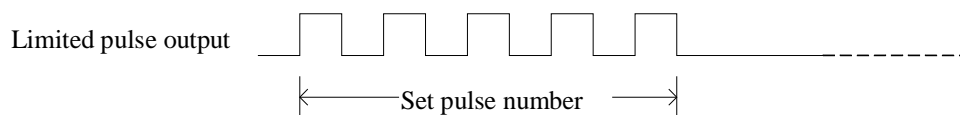

When finish sending the set pulse number, stop outputting automatically

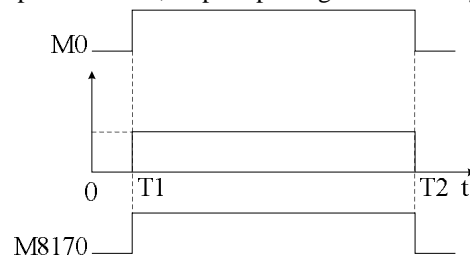

Note: T1 is pulse start time, T2 is pulse end time.

### Example

Pulse frequency=1000Hz, pulse quantity 20K, no acceleration/deceleration and single direction pulse output:

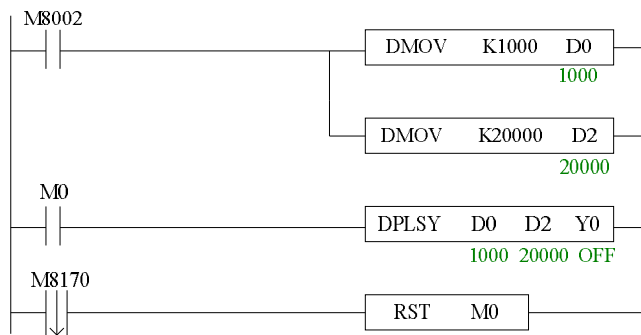

Note: D0 is pulse frequency, D2 is pulse quantity. D0=1000, D2=20000.

### Items to Note

If the control object is stepping/servo motor, we recommend users not use this instruction, to avoid the motor losing synchronism. PLSR is available.

## 6-2-2. Variable Pulse Output [PLSF]

PLSF has 4 control modes.

Mode 1: changeable frequency continuous pulse output PLSF

### 1、 Instruction Summary

Instruction to generate continuous pulse in the form of variable frequency

| Variable Pulse Output [PLSF] |                      |                        |                         |
|------------------------------|----------------------|------------------------|-------------------------|
| 16 bits<br>Instruction       | PLSF                 | 32 bits<br>Instruction | DPLSF                   |
| Execution condition          | Normally ON/OFF coil | Suitable Models        | XC2, XC3, XC5, XCM, XCC |
| Hardware requirement         | -                    | Software requirement   | -                       |

### 2、 Operands

| Operands | Function                             | Type                 |
|----------|--------------------------------------|----------------------|
| S        | Specify the frequency or register ID | 16 bits/32 bits, BIN |
| D        | Specify pulse output port            | bit                  |

## 3、 suitable soft components

|      |          |        |    |    |    |    |    |     |    |          |        |    |    |
|------|----------|--------|----|----|----|----|----|-----|----|----------|--------|----|----|
| Word | operands | system |    |    |    |    |    |     |    | constant | module |    |    |
|      |          | D      | FD | ED | TD | CD | DX | DY  | DM | DS       | K/H    | ID | QD |
|      | S        | •      | •  |    | •  | •  |    |     |    |          | •      |    |    |
| Bit  | operands | system |    |    |    |    |    |     |    |          |        |    |    |
|      |          | X      | Y  | M  | S  | T  | C  | Dnm |    |          |        |    |    |
|      | D        |        | •  |    |    |    |    |     |    |          |        |    |    |

### Functions and Actions

《16 bit instruction form》

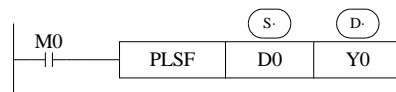

- Frequency range: 5Hz~32767Hz (when the set frequency is lower than 5Hz, output 5Hz)
- Pulse can only be output at Y0 or Y1.
- With the changing of setting frequency in D0, the output pulse frequency changes at Y0
- Accumulate pulse number in register D8170 (DWord)
- When pulse frequency is 0, the pulse output end
- There is no acceleration/deceleration time when the frequency changed
- When the condition is on, it output the pulse with changeable frequency until the condition is off. It is fit for changeable frequency continuous pulse output.

《32 bit instruction form》

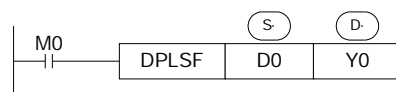

- Frequency range: 5Hz~200KHz (when the set frequency is lower than 5Hz, output 5Hz)
- Pulse can only be output at Y0 or Y1.
- With the changing of setting frequency in D0, the output pulse frequency changes at Y0
- Accumulate pulse number in register D8170 (DWord)
- There is no acceleration/deceleration time when the frequency changed
- When the condition is on, it output the pulse with changeable frequency until the condition is off. It is fit for changeable frequency continuous pulse output.

### Output Mode

Continuous pulse output



Continuous output pulse with the set frequency until stop output via the instruction

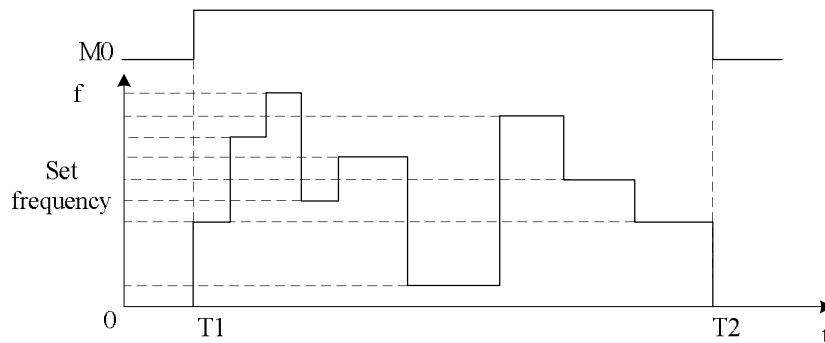

Note: T1 is pulse start time, T2 is pulse end time.

Mode2: changeable frequency continuous pulse output (with direction) PLSF

#### 1、 Instruction Summary

Instruction to generate continuous pulse in the form of variable frequency (with direction)

| Variable Pulse Output (with direction) [PLSF] |                      |                        |                         |
|---|----------------------|------------------------|-------------------------|
| 16 bits<br>Instruction                        | PLSF                 | 32 bits<br>Instruction | DPLSF                   |
| Execution condition                           | Normally ON/OFF coil | Suitable Models        | XC2, XC3, XC5, XCM, XCC |
| Hardware requirement                          | V3.3 and above       | Software requirement   | V3.3 and above          |

#### 2、 Operands

| Operands | Function                             | Type                 |
|----------|--------------------------------------|----------------------|
| S        | Specify the frequency or register ID | 16 bits/32 bits, BIN |
| D1       | Specify pulse output port            | bit                  |
| D2       | Specify pulse direction output port  | bit                  |

## 3、suitable soft components

| Word | operands | system |    |    |    |    |    |    |    | constant | module |    |    |
|------|----------|--------|----|----|----|----|----|----|----|----------|--------|----|----|
|      |          | D      | FD | ED | TD | CD | DX | DY | DM | DS       | K/H    | ID | QD |
| S    |          | •      | •  |    | •  | •  |    |    |    |          | •      |    |    |

| Bit | operands | system |   |   |   |   |   |     |
|-----|----------|--------|---|---|---|---|---|-----|
|     |          | X      | Y | M | S | T | C | Dnm |
| D1  |          |        | • |   |   |   |   |     |
| D2  |          |        | • |   |   |   |   |     |

### Functions And Actions

《16 bit instruction form》

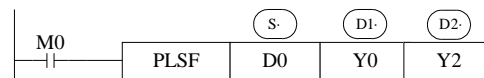

- Frequency range: 5Hz~32767Hz (when the set frequency is lower than 5Hz, output 5Hz)
- Pulse can only be output at Y0 or Y1.
- The negative/positive of pulse frequency decides the pulse direction ( direction port output when the frequency is positive)
- The direction output can control the rotation direction of motor (CW/CCW)
- With the changing of setting frequency in D0, the output pulse frequency changes at Y0
- Accumulate pulse number in register D8170 (DWord)
- There is no acceleration/deceleration time when the frequency changed
- When the condition is on, it output the pulse with changeable frequency until the condition is off. It is fit for changeable frequency continuous pulse output.

《32 bit instruction form》

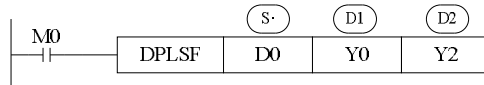

- Frequency range: 5Hz~200KHz (when the set frequency is lower than 5Hz, output 5Hz)
- Pulse can only be output at Y0 or Y1.
- The negative/positive of pulse frequency decides the pulse direction ( direction port output when the frequency is positive)
- The direction output can control the rotation direction of motor (CW/CCW)
- With the changing of setting frequency in D0, the output pulse frequency changes at Y0
- Accumulate pulse number in register D8170 (DWord)
- There is no acceleration/deceleration time when the frequency changed
- When the condition is on, it output the pulse with changeable frequency until the condition is

off. It is fit for changeable frequency continuous pulse output.

### Output Mode

Continuous pulse output



Continuous output pulse with the set frequency until stop output via the instruction

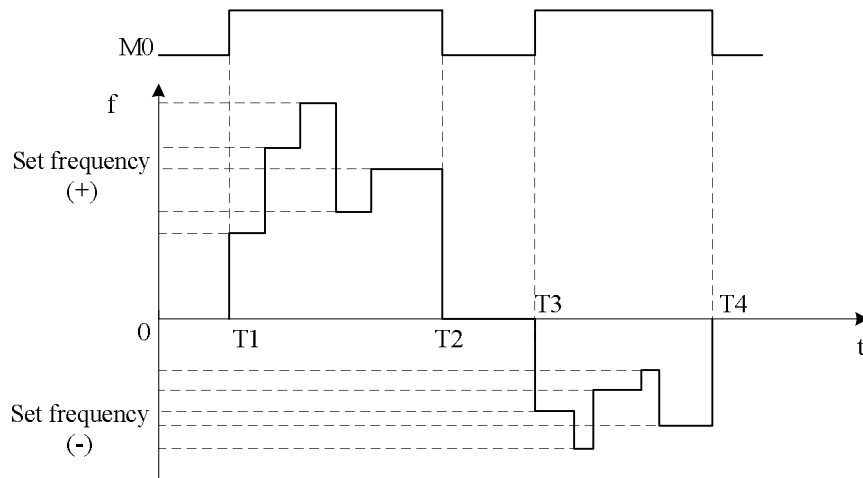

Note: T1 and T3 is pulse start time, T2 and T4 is pulse end time.

Mode3: changeable frequency limited quantity pulse output PLSF

#### 1、Instruction Summary

Instruction to generate changeable frequency limited quantity pulse

| Variable frequency limited quantity pulse output [PLSF] |                      |                         |                         |
|---|----------------------|-------------------------|-------------------------|
| 16 bits<br>Instruction                                  | PLSF                 | 32 bits<br>Instruction  | DPLSF                   |
| Execution<br>condition                                  | Normally ON/OFF coil | Suitable<br>Models      | XC2, XC3, XC5, XCM, XCC |
| Hardware<br>requirement                                 | V3.3 and above       | Software<br>requirement | V3.3 and above          |

#### 2、Operands

| Operands | Function                              | Type                 |
|----------|---------------------------------------|----------------------|
| S1       | Specify the frequency or register ID  | 16 bits/32 bits, BIN |
| S2       | Specify pulse quantity or register ID | 16 bits/32 bits, BIN |
| D        | Specify pulse output port             | bit                  |

## 3、suitable soft components

| Word | operands | system |    |    |    |    |    |    |    | constant | module |    |    |
|------|----------|--------|----|----|----|----|----|----|----|----------|--------|----|----|
|      |          | D      | FD | ED | TD | CD | DX | DY | DM | DS       | K/H    | ID | QD |
| S1   |          | •      | •  |    | •  | •  |    |    |    |          | •      |    |    |
| S2   |          | •      | •  |    | •  | •  |    |    |    |          | •      |    |    |

| Bit | operands | system |   |   |   |   |   |     |
|-----|----------|--------|---|---|---|---|---|-----|
|     |          | X      | Y | M | S | T | C | Dnm |
| D1  |          |        | • |   |   |   |   |     |

### Functions And Actions

《16 bit instruction form》

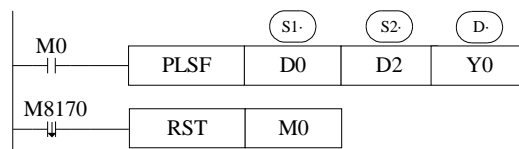

- Frequency range: 5Hz~32767Hz (when the set frequency is lower than 5Hz, output 5Hz)
- Pulse quantity range: K0~K32767
- Pulse can only be output at Y0 or Y1
- With the changing of setting frequency in D0, the output pulse frequency changes at Y0
- When the pulse frequency is 0Hz, the pulse output end
- Accumulate pulse number in register D8170 (DWord)
- There is no acceleration/deceleration time when the frequency changed
- When the condition is on, it output the pulse with changeable frequency until the condition is off. It is fit for changeable frequency limited quantity pulse output.
- When M0 is ON, PLSF output the pulse at Y0 with frequency D0 (word), pulse quantity D2 (word). M8170 is ON when the pulse is outputting. The pulse stops output when the pulse quantity reaches the limit value. And the M8170 is off, M0 is off.

《32 bit instruction form》

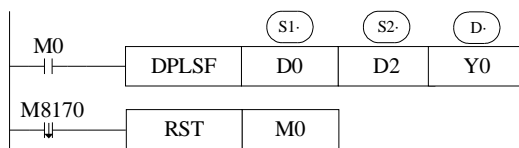

- Frequency range: 5Hz~200KHz (when the set frequency is lower than 5Hz, output 5Hz)
- Pulse quantity range: K0~K2147483647
- Pulse can only be output at Y0 or Y1

- With the changing of setting frequency in D0, the output pulse frequency changes at Y0
- When the pulse frequency is 0Hz, the pulse output end
- Accumulate pulse number in register D8170 (DWord)
- There is no acceleration/deceleration time when the frequency changed
- When the condition is on, it output the pulse with changeable frequency until the condition is off. It is fit for changeable frequency limited quantity pulse output.
- When M0 is ON, PLSF output the pulse at Y0 with frequency D0 (Dword), pulse quantity D2 (Dword). M8170 is ON when the pulse is outputting. The pulse stops output when the pulse quantity reaches the limit value. And the M8170 is off, M0 is off.

### Output Mode

Continuous pulse output



Continuous output pulse with the set frequency and limited pulse quantity

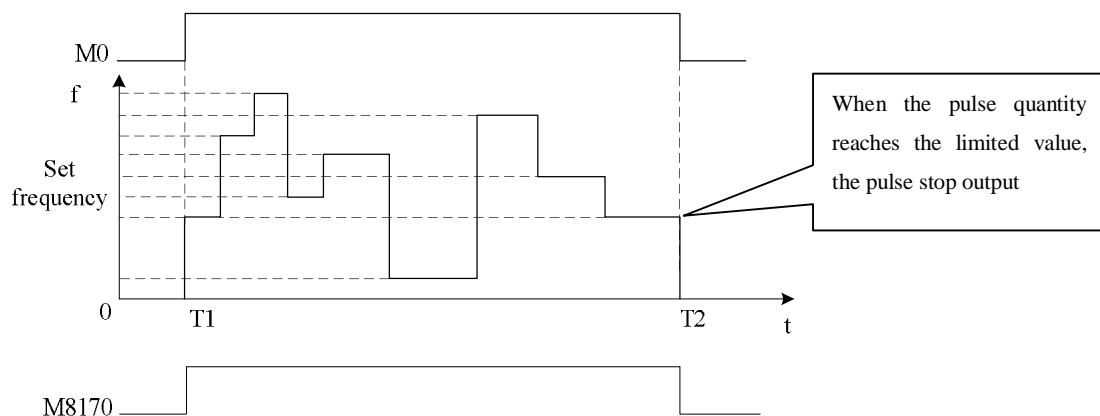

Note: T1 is pulse start time, T2 is pulse end time.

Mode4: changeable frequency limited quantity pulse output PLSF (with direction)

#### 1、 Instruction Summary

Instruction to generate changeable frequency limited quantity pulse (with direction)

| Variable frequency limited quantity pulse output (with direction) [PLSF] |                      |                         |                         |
|--|----------------------|-------------------------|-------------------------|
| 16 bits<br>Instruction   | PLSF                 | 32 bits<br>Instruction  | DPLSF                   |
| Execution<br>condition   | Normally ON/OFF coil | Suitable<br>Models      | XC2, XC3, XC5, XCM, XCC |
| Hardware<br>requirement  | V3.3 and above       | Software<br>requirement | V3.3 and above          |

## 2、Operands

| Operands | Function                              | Type                 |
|----------|---------------------------------------|----------------------|
| S1       | Specify the frequency or register ID  | 16 bits/32 bits, BIN |
| S2       | Specify pulse quantity or register ID | 16 bits/32 bits, BIN |
| D1       | Specify pulse output port             | bit                  |
| D2       | Specify pulse direction output port   | bit                  |

## 3、suitable soft components

| Word | operands | system |    |    |    |    |    |    |    | constant | module |    |    |
|------|----------|--------|----|----|----|----|----|----|----|----------|--------|----|----|
|      |          | D      | FD | ED | TD | CD | DX | DY | DM | DS       | K/H    | ID | QD |
|      | S1       | •      | •  |    | •  | •  |    |    |    |          | •      |    |    |
|      | S2       | •      | •  |    | •  | •  |    |    |    |          | •      |    |    |

| Bit | operands | system |   |   |   |   |   |     |
|-----|----------|--------|---|---|---|---|---|-----|
|     |          | X      | Y | M | S | T | C | Dnm |
|     | D1       |        | • |   |   |   |   |     |
|     | D2       |        | • |   |   |   |   |     |

### Functions And Actions

《16 bit instruction form》

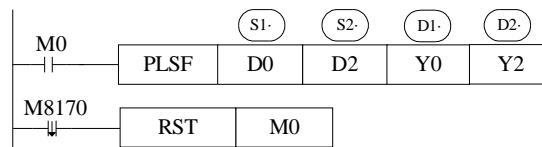

- Frequency range: 5Hz~32767Hz (when the set frequency is lower than 5Hz, output 5Hz)
- Pulse quantity range: K0~K32767
- Pulse can only be output at Y0 or Y1
- The negative/positive of pulse frequency decides the pulse direction ( direction port output when the frequency is positive)
- The direction output can control the rotation direction of motor (CW/CCW)
- With the changing of setting frequency in D0, the output pulse frequency changes at Y0
- When the pulse frequency is 0Hz, the pulse output end
- Accumulate pulse number in register D8170 (DWord)
- There is no acceleration/deceleration time when the frequency changed
- When the condition is on, it output the pulse with changeable frequency until the condition is off. It is fit for changeable frequency limited quantity pulse output.
- When M0 is ON, PLSF output the pulse at Y0 with frequency D0 (word), pulse quantity D2

(word). M8170 is ON when the pulse is outputting. The pulse stops output when the pulse quantity reaches the limit value. And the M8170 is off, M0 is off.

《32 bit instruction form》

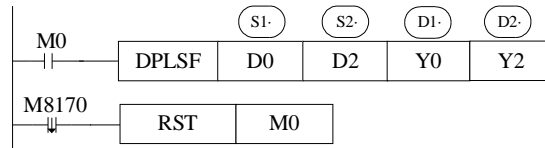

- Frequency range: 5Hz~200KHz (when the set frequency is lower than 5Hz, output 5Hz)
- Pulse quantity range: K0~K2147483647
- Pulse can only be output at Y0 or Y1
- With the changing of setting frequency in D0, the output pulse frequency changes at Y0
- When the pulse frequency is 0Hz, the pulse output end
- Accumulate pulse number in register D8170 (DWord)
- There is no acceleration/deceleration time when the frequency changed
- When the condition is on, it output the pulse with changeable frequency until the condition is off. It is fit for changeable frequency limited quantity pulse output.
- When M0 is ON, PLSF output the pulse at Y0 with frequency D0 (Dword), pulse quantity D2 (Dword). M8170 is ON when the pulse is outputting. The pulse stops output when the pulse quantity reaches the limit value. And the M8170 is off, M0 is off.

### Output Mode

Continuous pulse output



Continuous output pulse with the set frequency and limited pulse quantity

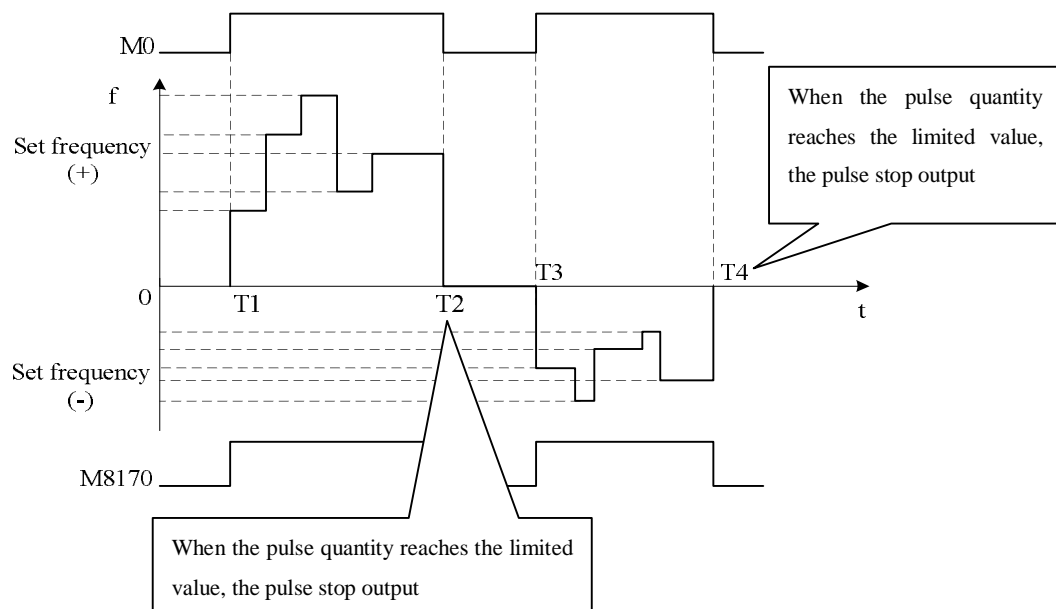



## Functions and Action

《16 bit instruction form》

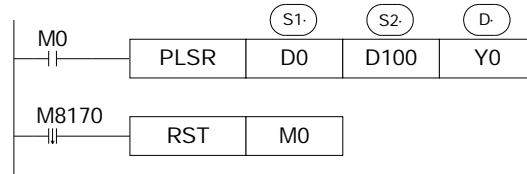

《32 bit instruction form》

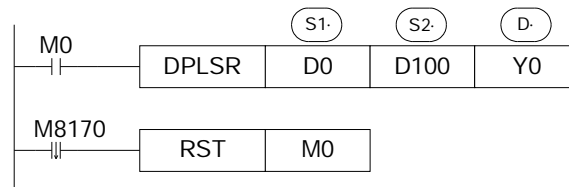

- The parameters' address is a section starts from **Dn** or **FDn**. In the above example (16bit instruction form): **D0** set the first segment pulse's highest frequency, **D1** set the first segment's pulse number, **D2** set the second segment pulse's highest frequency, **D3** set the second segment's pulse number, ..... if the set value in **Dn**, **Dn+1** is 0, this represents the end of segment, the segment number is not limited.
- For 32 bit instruction **DPLSR**, **D0**, **D1** set the first segment pulse's highest frequency, **D2**, **D3** set the first segment's pulse number, **D4**, **D5** set the second segment pulse's highest frequency, **D6**, **D7** set the second segment's pulse number.....
- Acceleration/deceleration time is the time from the start to the first segment's highest frequency. Meantime, it defines the slope of all segment's frequency to time. In this way the following acceleration/deceleration will perform according to this slope.
- Pulse can be output at only Y000 or Y001
- Frequency range: 0~32767Hz (16 bits instruction), 0~200KHz (32 bits instruction)
- Acceleration/deceleration time : 0~65535 ms

Note: the address of pulse segment must be continuous and the pulse frequency and quantity of segment N+1 must be 0. Acceleration/deceleration time address cannot behind segment N.

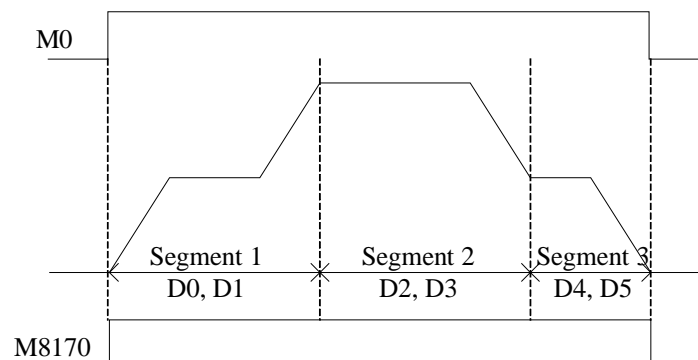

**Example**

Send 6 segments of pulse, the pulse frequency and quantity please see below table:

| Name                           | Pulse frequency (Hz) | Pulse quantity |
|--------------------------------|----------------------|----------------|
| Segment 1                      | 1000                 | 2000           |
| Segment 2                      | 200                  | 1000           |
| Segment 3                      | 3000                 | 6000           |
| Segment 4                      | 800                  | 1600           |
| Segment 5                      | 100                  | 800            |
| Segment 6                      | 1200                 | 3000           |
| Acceleration/deceleration time | 100ms                |                |

Use 32-bit instruction DPLSR, the address is shown as the following table:

| Name                                  | Pulse frequency(Hz) | Frequency address (Dword) | Pulse quantity | pulse quantity address (Dword) |
|---------------------------------------|---------------------|---------------------------|----------------|--------------------------------|
| Segment 1                             | 1000                | D1, D0                    | 2000           | D3, D2                         |
| Segment 2                             | 200                 | D5, D4                    | 1000           | D7, D6                         |
| Segment 3                             | 3000                | D9, D8                    | 6000           | D11, D10                       |
| Segment 4                             | 800                 | D13, D12                  | 1600           | D15, D14                       |
| Segment 5                             | 100                 | D17, D16                  | 800            | D19, D18                       |
| Segment 6                             | 1200                | D21, D20                  | 3000           | D23, D22                       |
| Acceleration/<br>deceleration<br>time | 100ms               |                           | D51, D0        |                                |

Note: the 4 registers behind segment 6 must be 0 (D27, D26, D25, D24), which means the pulse output end; for 16 bits instruction, D25, D24 must be 0.

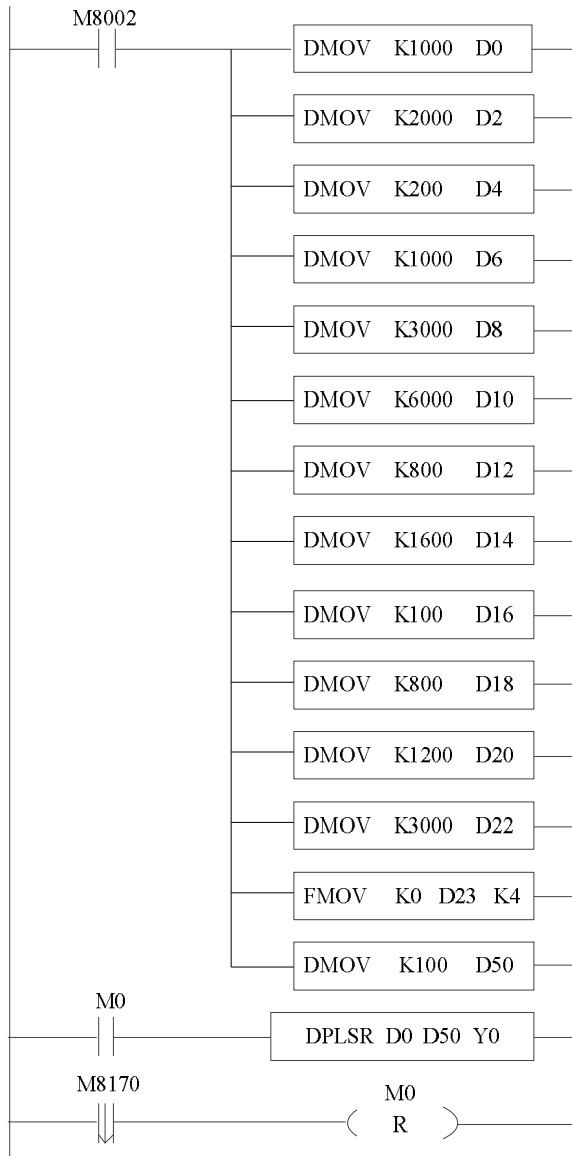

## Mode 2: segmented dual-direction pulse output PLSR

### 1、 Instruction Summary

Generate certain pulse quantity with the specified frequency、 acceleration/deceleration time and pulse direction;

| Segmented dual-directional pulse output [PLSR] |                      |                         |                         |
|--|----------------------|-------------------------|-------------------------|
| 16 bits<br>Instruction                         | PLSR                 | 32 bits<br>Instruction  | DPLSR                   |
| Execution<br>condition                         | Normally ON/OFF coil | Suitable<br>Models      | XC2, XC3, XC5, XCM, XCC |
| Hardware<br>requirement                        | -                    | Software<br>requirement | -                       |

## 2、 Operands

| Operands | Function  | Type                |
|----------|---|---------------------|
| S1       | Specify the soft component's start ID of the segmented pulse parameters | 16 bit/ 32 bit, BIN |
| S2       | Specify acceleration/deceleration time or soft component's ID           | 16 bit/ 32 bit, BIN |
| D1       | Specify the pulse output port   | Bit                 |
| D2       | Specify the pulse output direction's port                               | Bit                 |

## 3、 suitable soft components

| Word | operands | system |    |    |    |    |    |    |    | constant | module |    |    |
|------|----------|--------|----|----|----|----|----|----|----|----------|--------|----|----|
|      |          | D      | FD | ED | TD | CD | DX | DY | DM | DS       | K/H    | ID | QD |
|      | S1       | •      | •  |    | •  | •  |    |    |    |          |        |    |    |
|      | S2       | •      | •  |    | •  | •  |    |    |    |          | K      |    |    |

| Bit | operands | system |   |   |   |   |   |     |
|-----|----------|--------|---|---|---|---|---|-----|
|     |          | X      | Y | M | S | T | C | Dnm |
|     | D1       |        | • |   |   |   |   |     |
|     | D2       |        | • |   |   |   |   |     |

## Functions And Actions

《16 bit instruction form》

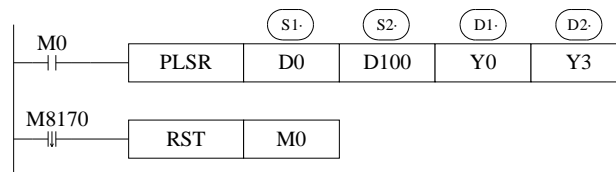

- The parameters' address is a section starts from **Dn** or **FDn**. In the above example: **D0** set the first segment pulse's highest frequency, **D1** set the first segment's pulse number, **D2** set the second segment pulse's highest frequency, **D3** set the second segment's pulse number, ..... if the set value in **Dn**, **Dn+1** is 0, this represents the end of segment, the segment number is not limited.
- For 32 bit instruction **DPLSR**, **D0**, **D1** set the first segment pulse's highest frequency, **D2**, **D3** set the first segment's pulse number, **D4**, **D5** set the second segment pulse's highest frequency, **D6**, **D7** set the second segment's pulse number.....
- Acceleration/deceleration time is the time from the start to the first segment's highest frequency. Meantime, it defines the slope of all segment's frequency to time. In this way the following acceleration/deceleration will perform according to this slope.

- Pulse can be output at only Y0 or Y1
- Pulse direction output terminal Y can be specified freely. E.g.: if in S1 (the first segment) the pulse number is positive, Y output is ON; if the pulse number is negative, Y output is OFF; Note: the pulse direction is decided by the pulse number's nature (positive or negative) of the first segment.
- Frequency range: 0~32767Hz (16 bits), 0~200KHz (32 bits)
- Pulse number range: 0~K32,767 (16 bits instruction), 0~K2,147,483,647 (32 bits instruction)
- Acceleration/deceleration time : below 65535 ms

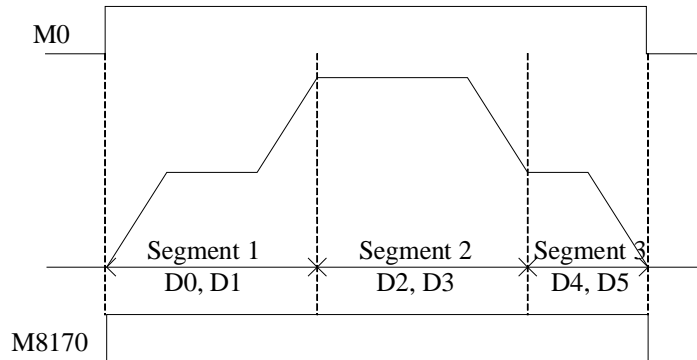
**Example**

6 segments pulse output. The pulse frequency and quantity are shown in the following table:

| Name                           | Pulse frequency (Hz) | Pulse quantity |
|--------------------------------|----------------------|----------------|
| Segment 1                      | 1000                 | 2000           |
| Segment 2                      | 200                  | 1000           |
| Segment 3                      | 3000                 | 6000           |
| Segment 4                      | 800                  | 1600           |
| Segment 5                      | 100                  | 800            |
| Segment 6                      | 1200                 | 3000           |
| Acceleration/deceleration time | 100ms                |                |

Use 32bits instruction DPLSR, the address is shown as the following table:

| Name          | Pulse frequency (Hz) | Frequency address (Dword) | Pulse quantity | Pulse quantity address (Dword) |
|---------------|----------------------|---------------------------|----------------|--------------------------------|
| Segment 1     | 1000                 | D1, D0                    | 2000           | D3, D2                         |
| Segment 2     | 200                  | D5, D4                    | 1000           | D7, D6                         |
| Segment 3     | 3000                 | D9, D8                    | 6000           | D11, D10                       |
| Segment 4     | 800                  | D13, D12                  | 1600           | D15, D14                       |
| Segment 5     | 100                  | D17, D16                  | 800            | D19, D18                       |
| Segment 6     | 1200                 | D21, D20                  | 3000           | D23, D22                       |
| Acceleration/ | 100ms                |                           | D51, D0        |                                |

|                      |  |  |
|----------------------|--|--|
| deceleration<br>time |  |  |
|----------------------|--|--|

Note: the 4 registers behind segment 6 must be 0 (D27, D26, D25, D24), which means the pulse output end; for 16 bits instruction, D25, D24 must be 0.

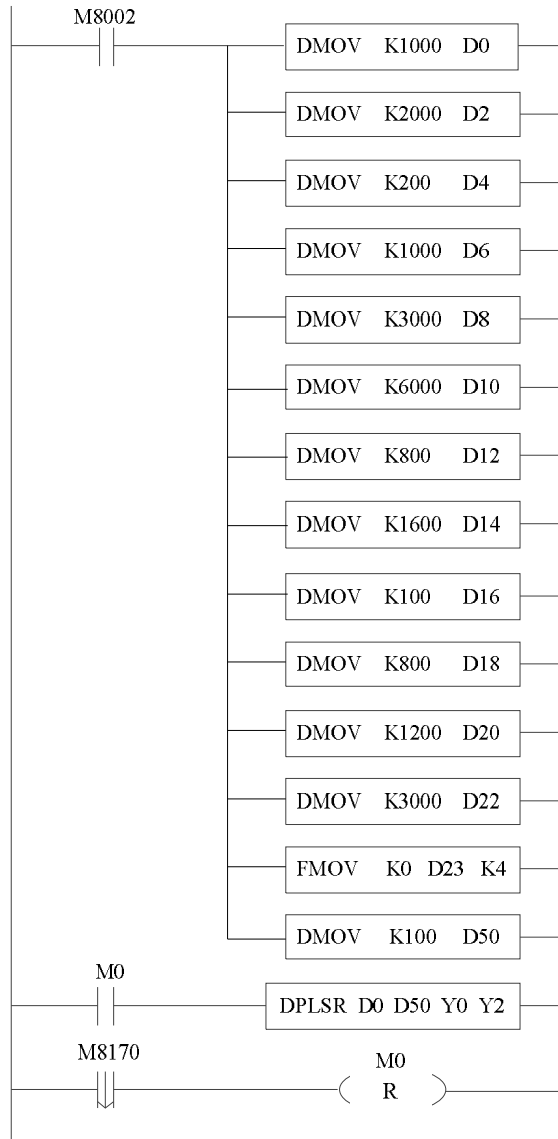

### 6-2-4. Pulse Segment Switch [PLSNEXT]/[PLSNT]

#### 1、 Instruction Summary

Enter the next segment of pulse output;

| Pulse segment switch [PLSNEXT]/[PLSNT] |                     |                         |                         |
|--|---------------------|-------------------------|-------------------------|
| 16 bits<br>Instruction                 | PLSNEXT/PLSNT       | 32 bits<br>Instruction  | -                       |
| Execution<br>condition                 | Rising/falling edge | Suitable<br>Models      | XC2, XC3, XC5, XCM, XCC |
| Hardware<br>requirement                | -                   | Software<br>requirement | -                       |

#### 2、 Operands

| Operands | Function                      | Type |
|----------|-------------------------------|------|
| D        | Specify the pulse output port | Bit  |

#### 3、 suitable soft components

| Bit | operands | system |   |   |   |   |     |
|-----|----------|--------|---|---|---|---|-----|
|     | X        | Y      | M | S | T | C | Dnm |
| D   |          | •      |   |   |   |   |     |

### Functions And Actions

《16 bit instruction form》

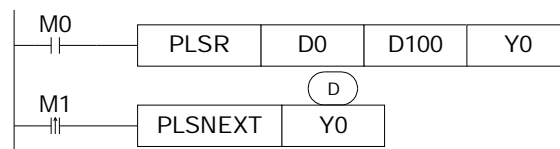

- If the pulse output reaches the highest frequency at the current segment, and output steadily at this frequency; when M1 changes from OFF to ON, then enter the next pulse output with the acceleration/deceleration time; (this instruction is suitable for multi-segment pulse output)
- Run the instruction within the acceleration/deceleration time is invalid
- Instruction PLSNT is the same to PLSNEXT

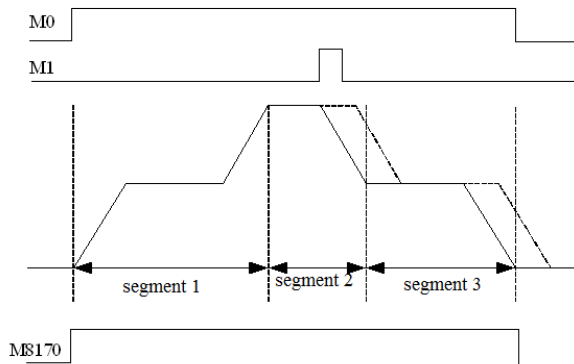

----- the dashed line represents the original pulse output

**Example**

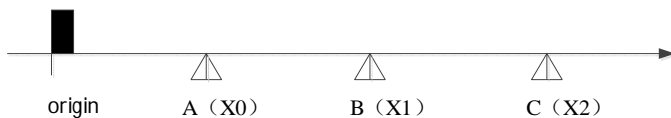

The object needs to move from A to B to C. The speed of the three segments is different. The position of A, B and C is uncertain. We can use DPLSR and PLSNEXT to make this program. We can use proximity switch in position A, B, C. Connect the proximity to PLC terminal X1, X2, X3. Pulse frequency terminal is Y0, pulse direction terminal is Y2.

| Name                            | Pulse frequency (Hz) | Frequency address (Dword) | Pulse quantity | Pulse quantity address (Dword) |
|---------------------------------|----------------------|---------------------------|----------------|--------------------------------|
| Segment origin-A                | 1000                 | D1, D0                    | 99999999       | D3, D2                         |
| Segment A-B                     | 3000                 | D5, D4                    | 99999999       | D7, D6                         |
| Segment B-C                     | 2000                 | D9, D8                    | 99999999       | D11, D10                       |
| Acceleration/ deceleration time | 30ms                 |                           | D31, D30       |                                |

Note: the pulse quantity should be set to a large value to ensure it can reach the proximity switch. Please clear the 4 registers behind segment 3. (D15, D14, D13, D12).

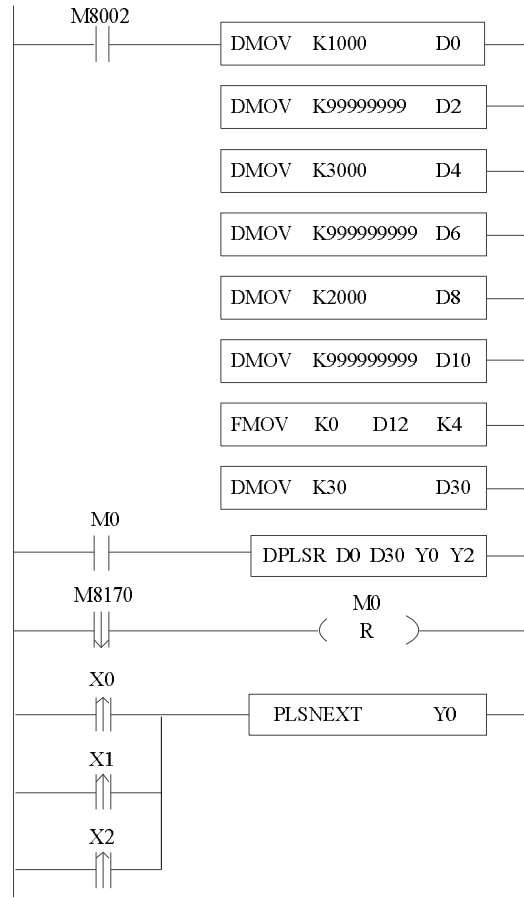
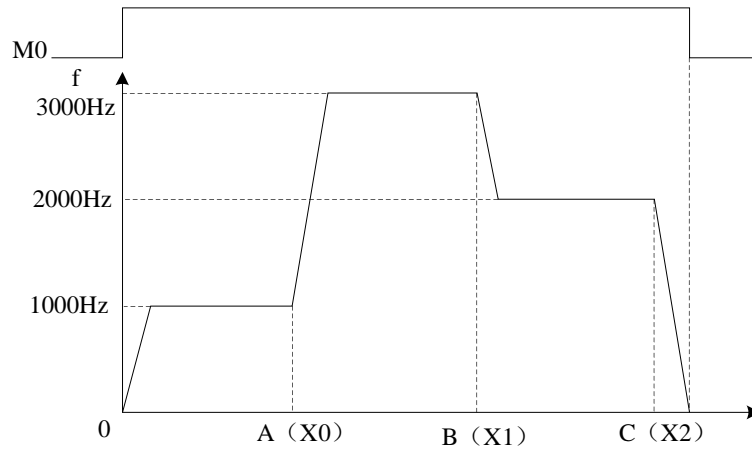

Diagram:



### 6-2-5. Pulse Stop [STOP]

#### 1、 Instruction Summary

Stop pulse output immediately;

| Pulse stop [STOP]       |                     |                         |                         |
|-------------------------|---------------------|-------------------------|-------------------------|
| 16 bits<br>Instruction  | STOP                | 32 bits<br>Instruction  | -                       |
| Execution<br>condition  | Rising/falling edge | Suitable<br>Models      | XC2, XC3, XC5, XCM, XCC |
| Hardware<br>requirement | -                   | Software<br>requirement | -                       |

#### 2、 Operands

| Operands | Function                              | Type |
|----------|---------------------------------------|------|
| D        | Specify the port to stop pulse output | Bit  |

#### 3、 suitable soft components

| Bit | operands | system |   |   |   |   |     |  |
|-----|----------|--------|---|---|---|---|-----|--|
|     | X        | Y      | M | S | T | C | Dnm |  |
| D   |          | •      |   |   |   |   |     |  |

### Functions And Actions

《16 bit instruction form》

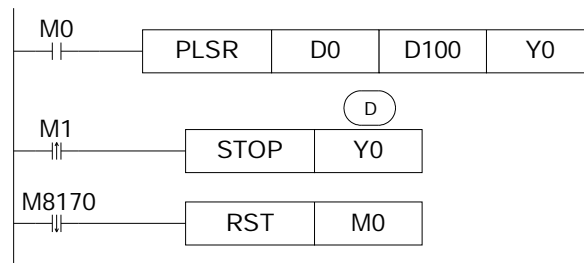

- When M0 changes from OFF to be ON, PLSR output pulse at Y0. D0 specify the frequency, D1 specify the pulse number, D100 specify the acceleration/deceleration time; when the output pulse number reaches the set value, stop outputting the pulse; on the rising edge of M1, STOP instruction stops outputting the pulse at Y0;
- When STOP works, the pulse will stop at once even the M0 is not off.

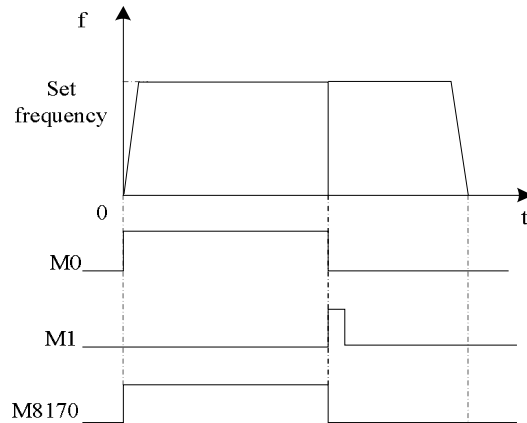

### 6-2-6. Refresh the pulse number at the port [PLSMV]

#### 1、 Instruction Summary

Refresh the pulse number at the port;

| Refresh the pulse number at the port [PLSMV] |                      |                         |                         |
|--|----------------------|-------------------------|-------------------------|
| 16 bits<br>Instruction                       | -                    | 32 bits<br>Instruction  | PLSMV                   |
| Execution<br>condition                       | Normally ON/OFF coil | Suitable<br>Models      | XC2, XC3, XC5, XCM, XCC |
| Hardware<br>requirement                      | -                    | Software<br>requirement | -                       |

#### 2、 Operands

| Operands | Function  | Type       |
|----------|---|------------|
| S        | Specify the pulse number or soft components' ID | 32bit, BIN |
| D        | Specify the port to refresh the pulse           | Bit        |

#### 3、 suitable soft components

|      |          |        |    |    |    |    |    |     |    |          |        |    |
|------|----------|--------|----|----|----|----|----|-----|----|----------|--------|----|
| Word | operands | system |    |    |    |    |    |     |    | constant | module |    |
|      |          | D      | FD | ED | TD | CD | DX | DY  | DM | DS       | K/H    | ID |
|      | S        | •      | •  |    | •  | •  |    |     |    |          | •      |    |
| Bit  | operands | system |    |    |    |    |    |     |    |          |        |    |
|      |          | X      | Y  | M  | S  | T  | C  | Dnm |    |          |        |    |
|      | D        |        | •  |    |    |    |    |     |    |          |        |    |

## Functions And Actions

《32 bit instruction form》

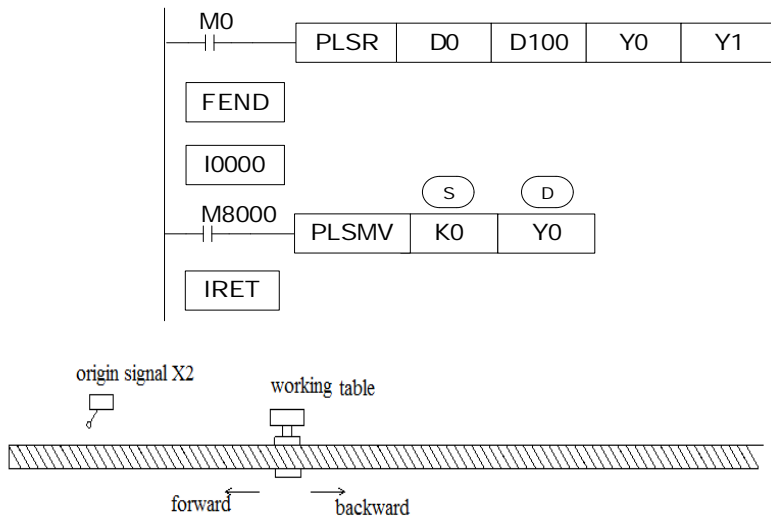

- When the working table is moving backward, it gets the origin signal X2, execute the external interruption, PLSMV command run immediately, not effected by the scan cycle. Refresh the pulse number from Y0 and send to D8170;
- This instruction is used to clear the accumulation difference caused in pulse control;
- **PLSMV instruction is only for PLSR and DPLSR.**

### 6-2-7. Back to the Origin [ZRN]

#### Method 1: Simple ZRN

##### 1、Instruction Summary

Back to the Origin

| Back to the Origin [ZRN] |                      |                      |                         |
|--------------------------|----------------------|----------------------|-------------------------|
| 16 bits Instruction      | ZRN                  | 32 bits Instruction  | DZRN                    |
| Execution condition      | Normally ON/OFF coil | Suitable Models      | XC2, XC3, XC5, XCM, XCC |
| Hardware requirement     | -                    | Software requirement | -                       |

2、 Operands

| Operands | Function  | Type           |
|----------|---|----------------|
| S1       | Specify the backward speed or soft components' ID           | 16/32bit, BIN  |
| S2       | Specify the creeping speed or soft components' ID           | 16/32 bit, BIN |
| S3       | Specify the soft components' ID of the close point's signal | Bit            |
| D        | Specify the pulse output port                               | Bit            |

3、 suitable soft components

| Word | operands | system |    |    |    |    |    |    |    | constant | module |    |    |
|------|----------|--------|----|----|----|----|----|----|----|----------|--------|----|----|
|      |          | D      | FD | ED | TD | CD | DX | DY | DM | DS       | K/H    | ID | QD |
|      | S1       | •      | •  |    | •  | •  |    |    |    |          | •      |    |    |
|      | S2       | •      | •  |    | •  | •  |    |    |    |          | •      |    |    |

| Bit | operands | system |   |   |   |   |   |     |
|-----|----------|--------|---|---|---|---|---|-----|
|     |          | X      | Y | M | S | T | C | Dnm |
|     | S3       | •      |   | • |   |   |   |     |
|     | D        |        | • |   |   |   |   |     |

**Functions And Actions**

《16 bit instruction form》

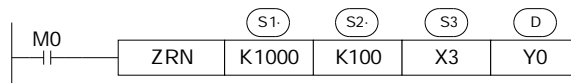

《32 bit instruction form》

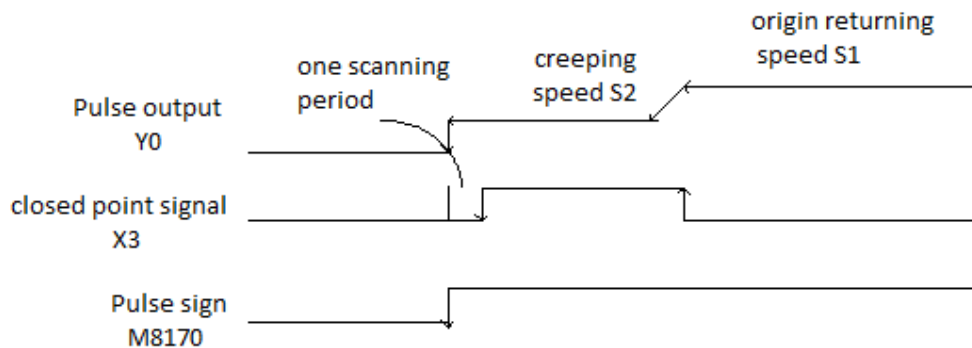
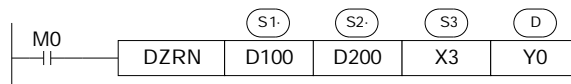

- Pulse output address: Y0 or Y1 only; XC5 series is Y0~Y3, 3 axis is Y0~Y2, 10 axis is Y0~Y11.
- S1 and S2 direction is same and the absolute value of S1 is greater than S2;
- After driving the instruction, move to signal X3 with origin returning speed S1;
- When the closed point signal turns from OFF to be ON, decrease the speed to be S2;
- When the closed point signal X3 turns from OFF to ON, accelerate from origin returning speed to creeping speed S2.
- When the closed point signal X3 turns from ON to be OFF, after one scanning period, write to registers (Y0:[D8171,D8170]=0,Y1:[D8174,D8173]=0) when stopping pulse output;
- No acceleration/deceleration time when the instruction works at the beginning, the pulse frequency changes from 0Hz to S1 suddenly
- The decrease time can be specified by D8230~D8239; please refer to chapter 6-6 for details;

### Method 2: High precision ZRN

#### 1、 Summary

High precision back to the origin

| Back to the origin [ZRN] |                      |                 |                         |
|--------------------------|----------------------|-----------------|-------------------------|
| 16 bits                  | -                    | 32 bits         | ZRN                     |
| Execution condition      | Normally ON/OFF coil | Suitable models | XC2, XC3, XC5, XCM, XCC |
| Hardware                 | V3.3 and higher      | Software        | V3.3 and higher         |

#### 2、 Operand

| Operand | Function   | Type         |
|---------|--|--------------|
| S0      | Soft element head address of origin back data block            | 32 bits, BIN |
| S1      | Soft element address of limit signal                           | bit          |
| S2      | Soft element address of origin auxiliary signal                | bit          |
| S3      | Soft element address of origin signal (external interruption)  | bit          |
| S4      | Soft element address of Z phase signal (external interruption) | bit          |
| D1      | Address of pulse output terminal                               | bit          |
| D2      | Address of pulse output direction terminal                     | bit          |

3、Suitable soft element

|      |         |        |    |    |    |    |    |    |    |          |        |    |    |
|------|---------|--------|----|----|----|----|----|----|----|----------|--------|----|----|
| Word | operand | System |    |    |    |    |    |    |    | constant | Module |    |    |
|      |         | D      | FD | ED | TD | CD | DX | DY | DM | DS       | K/H    | ID | QD |
|      | S0      | •      | •  |    | •  | •  |    |    |    |          |        |    |    |

|     |         |        |   |   |   |   |   |     |
|-----|---------|--------|---|---|---|---|---|-----|
| Bit | Operand | System |   |   |   |   |   |     |
|     |         | X      | Y | M | S | T | C | Dnm |
|     | S1、S2   | •      |   | • | • | • | • |     |
|     | S3、S4   | •      |   |   |   |   |   |     |
|     | D1、D2   |        | • |   |   |   |   |     |

**Description**

《Mode1: no Z phase signal》

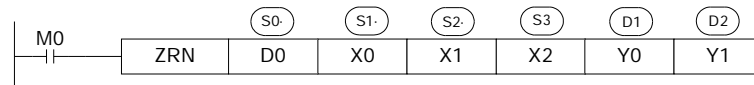

《Mode2: with Z phase signal》

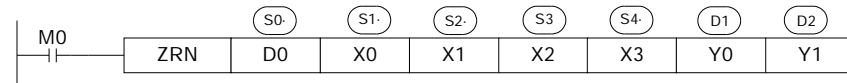

Parameter address distribution: (32 bits, 2 bytes)

- S0 : back to origin speed VH
- S0+2 : back to origin speed VL
- S0+4 : creep speed
- S0+6 : slope of pulse rising and falling
- S0+8 : initial pulses after back to origin (D8170)
- S0+10: Z phase count value (for mode2)

(A) back start point is behind the origin

Mode1:

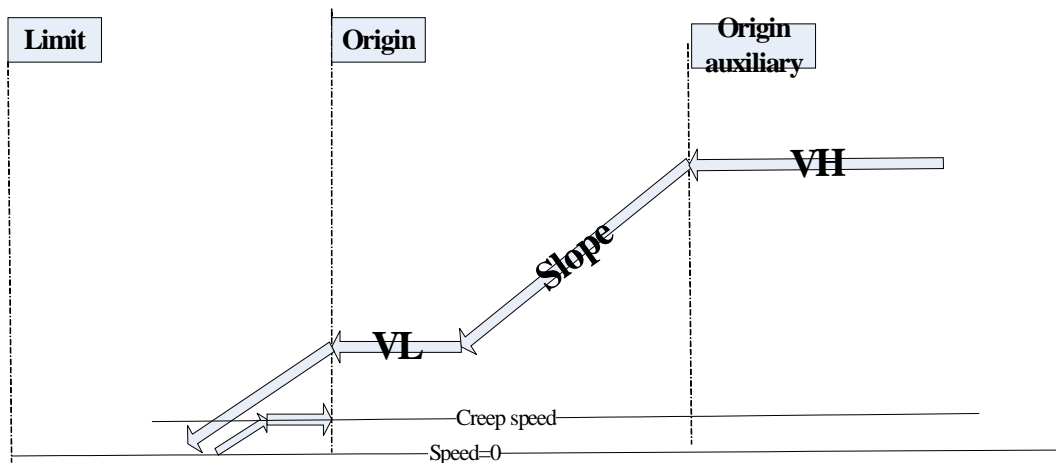

Description:

- Move towards the origin with speed VH.
- If it encounters origin auxiliary signal S2, it will decelerate to speed VL with the slope K (note: if it encounters the origin when decelerating from VH to VL, please modify the pulse slope or origin position to avoid it).
- Keep forward with the current speed VL.
- Decelerate to 0 with the slope K after touching the origin.
- Start to delay (delay time is FD8209, unit is ms). It accelerates to creep speed with the slope K after delaying.
- Move in reverse direction with creep speed.
- Stop origin returning when it leaves the origin with creep speed.
- Change the pulses (D8170) to setting value.

**Note:** in this mode, please keep the origin limit switch ON during the process (from touching the origin limit switch at speed VL to stop origin returning)

Mode2:

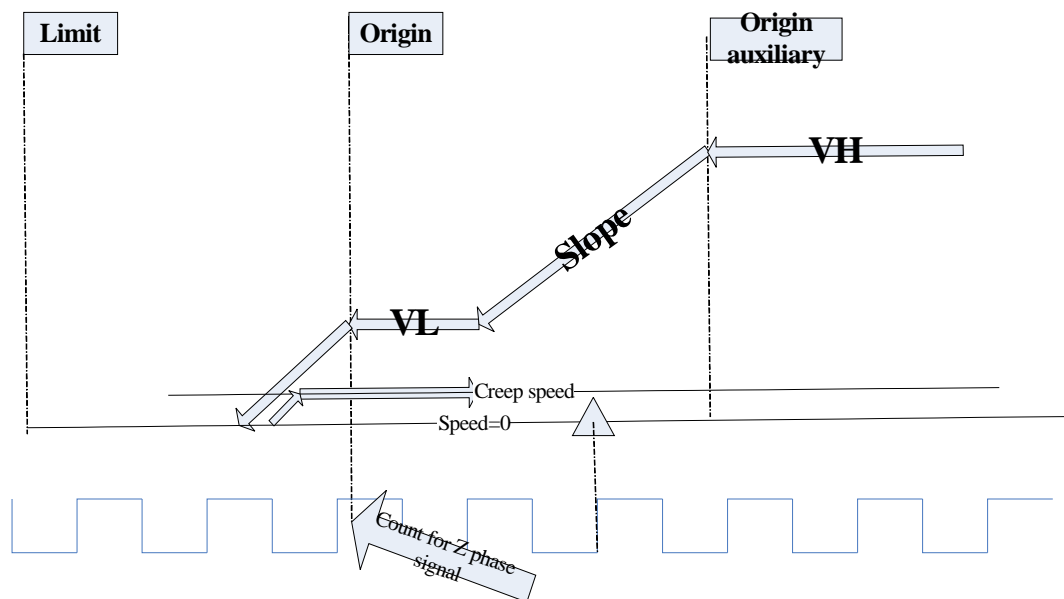

Description:

- Move towards origin with speed VH.
- If it encounters origin auxiliary signal S2, decelerate to speed VL with slope K.
- Move forward at speed VL.
- Decelerate to 0 with slope K when encountering the origin.
- Start to delay (the delay time is FD8209, unit is ms). Accelerate to creep speed with the slope K.
- Move in reverse direction at creep speed.
- Stop Z phase counting when leaving the origin at creep speed.
- Stop origin returning when Z phase cumulative value is equal to setting value.

- Change the pulses (D8170) to setting value.

**Note:** in this mode, please keep the origin limit switch ON during the process (from touching the origin limit switch at speed VL to stop origin returning)

(B) the start point is ahead the origin, with limit signal

Mode1:

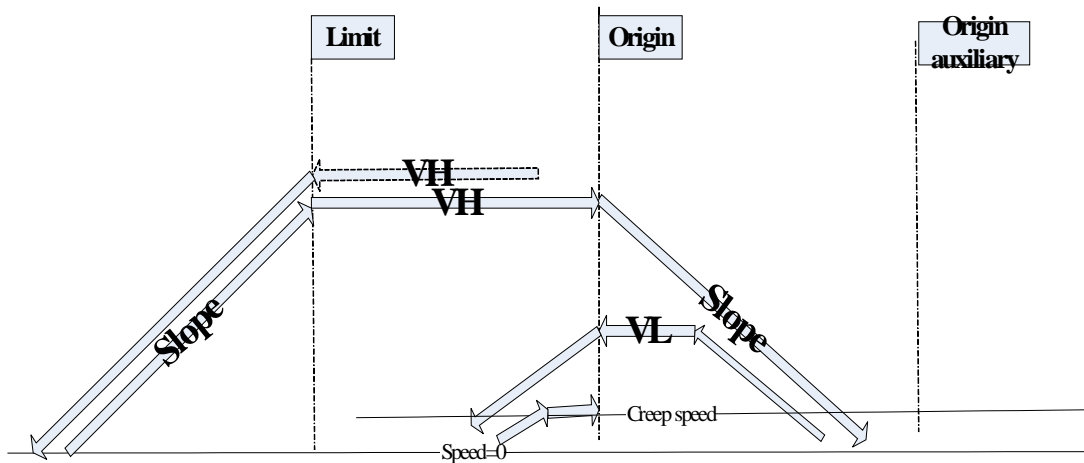

Description:

- Move towards origin at speed VH, when touching the limit switch, it decelerate to 0 with slope K.
- Start to delay (delay time is FD8209, the unit is ms). Accelerate to speed VH with slope K after delaying.
- Run at speed VH.
- Decelerate to 0 with slope K when encountering origin.
- Accelerate to speed VL with slope K and move towards origin.
- Decelerate to 0 with slope K when touching the origin.
- Start to delay (delay time is FD8209, the unit is ms). Accelerate to creep speed with slope K.
- Stop after leaving the origin at creep speed.
- Change the pulses (D8170) to setting value.

**Note:** in this mode, please keep the origin limit switch ON during the process (from touching the origin limit switch at speed VL to stop origin returning)

Mode2:

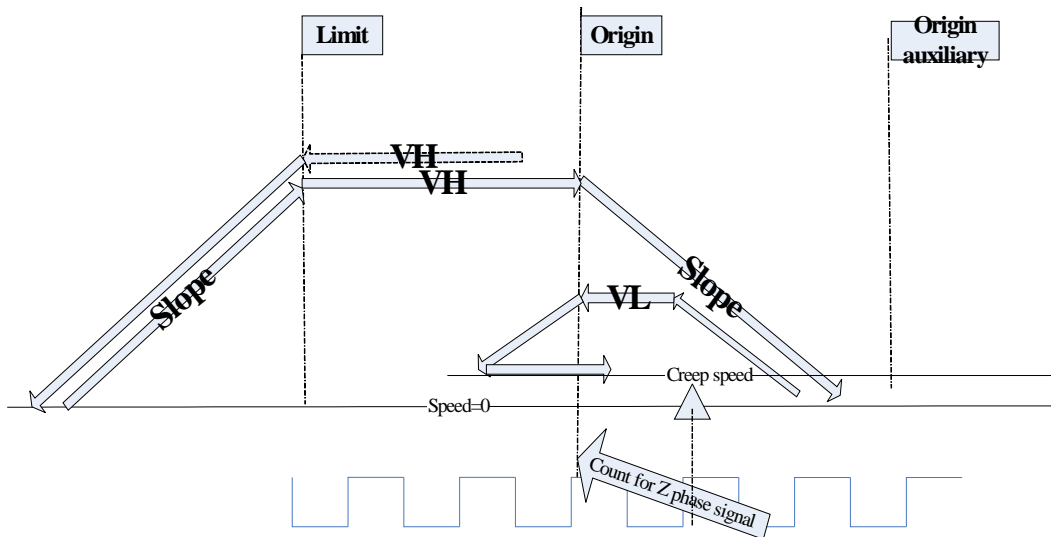

Description:

- Move towards origin at speed VH, decelerate to 0 with slope K when touching the limit signal.
- Start to delay (delay time is FD8209, the unit is ms). Accelerate to speed VH with slope K after delaying.
- Run at speed VH.
- Decelerate to 0 with slope K when encountering the origin.
- Accelerate to speed VL with slope K and move toward origin.
- Decelerate to 0 with slope K when touching the origin.
- Start to delay (delay time is FD8209, the unit is ms). Accelerate to creep speed with slope K after delaying.
- Start to count Z phase signal after leaving origin at creep speed.
- Stop origin returning when cumulative value of Z phase signal is equal to setting value.
- Change the pulses to setting value. (D8170)

**Note:** in this mode, please keep the origin limit switch ON during the process (from touching the origin limit switch at speed VL to stop origin returning)

## 6-2-8. Relative position single-segment pulse control [DRVI]

### 1、Instruction Summary

Relative position single-segment pulse control;

| Relative position single-segment pulse control [DRVI] |                      |                        |                         |
|---|----------------------|------------------------|-------------------------|
| 16 bits<br>Instruction                                | DRVI                 | 32 bits<br>Instruction | DDRVI                   |
| Execution<br>condition                                | Normally ON/OFF coil | Suitable<br>Models     | XC2, XC3, XC5, XCM, XCC |

|                      |   |                      |   |
|----------------------|---|----------------------|---|
| Hardware requirement | - | Software requirement | - |
|----------------------|---|----------------------|---|

2、 Operands

| Operands | Function   | Type           |
|----------|--|----------------|
| S1       | Specify the output pulse value or soft components ID     | 16/32bit, BIN  |
| S2       | Specify the output pulse frequency or soft components ID | 16/32 bit, BIN |
| D1       | Specify the pulse output port                            | Bit            |
| D2       | Specify the pulse output direction port                  | Bit            |

3、 suitable soft components

|      |          |        |    |    |    |    |    |     |    |          |        |    |
|------|----------|--------|----|----|----|----|----|-----|----|----------|--------|----|
| Word | operands | system |    |    |    |    |    |     |    | constant | module |    |
|      |          | D      | FD | ED | TD | CD | DX | DY  | DM | DS       | K/H    | ID |
|      | S1       | •      | •  |    | •  | •  |    |     |    |          | •      |    |
|      | S2       | •      | •  |    | •  | •  |    |     |    | •        |        |    |
| Bit  | operands | system |    |    |    |    |    |     |    |          |        |    |
|      |          | X      | Y  | M  | S  | T  | C  | Dnm |    |          |        |    |
|      | D1       |        | •  |    |    |    |    |     |    |          |        |    |
|      | D2       |        | •  |    |    |    |    |     |    |          |        |    |

**Functions And Actions**

《16 bit instruction form》

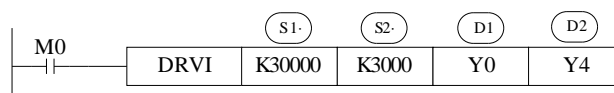

《32 bit instruction form》

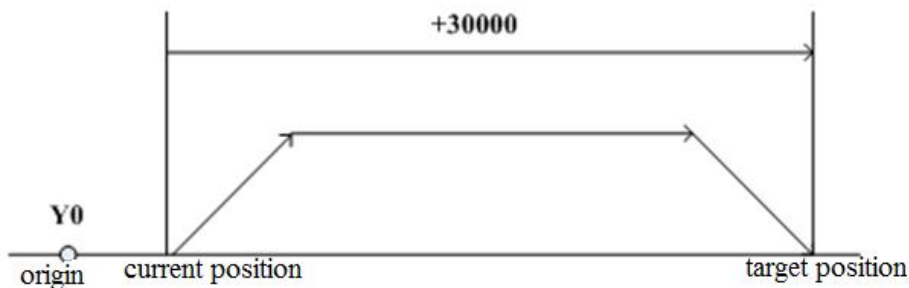
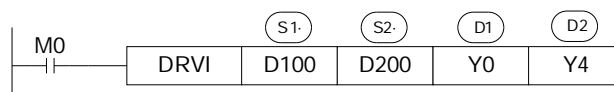

- Pulse output ID: only Y0 or Y1; XC5 series is Y0~Y3, 3 axis is Y0~Y2, 10 axis is Y0~Y11
- Pulse output direction can specify any Y;
- Acceleration/deceleration time is specified by D8230 (single word)

- The relative drive form means: move from the current position (the distance from current position to target position);
- Confirm the value of current position registers before executing the instruction (D8171, D8170[Y0]/ D8174, D8173[Y1] .....)

### Example

The current position of X axis is (100, 0), it will move to target position (3000, 0) at the speed of 1000Hz, pulse output terminal is Y0, direction terminal is Y4. The distance between current position and target position is  $2900=3000-100$ . The DRVI executing diagram is shown as below:

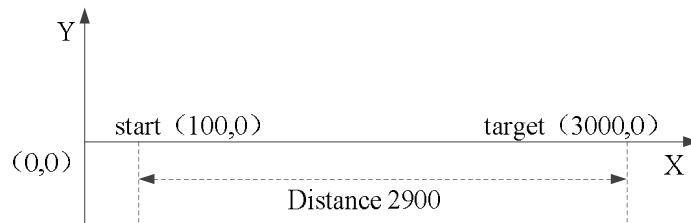

Program:

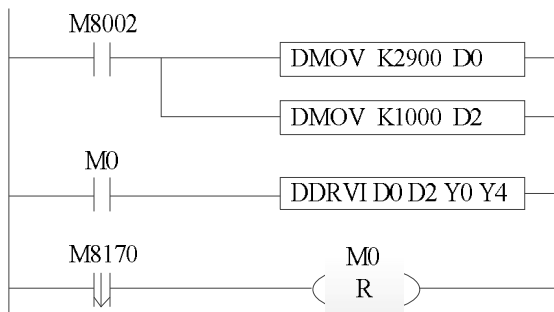

## 6-2-9. Absolute position single-segment pulse control [DRVA]

### 1、Instruction Summary

Absolute position single-segment pulse control

| Absolute position single-segment pulse control [DRVA] |                      |                         |                         |
|---|----------------------|-------------------------|-------------------------|
| 16 bits<br>Instruction                                | DRVA                 | 32 bits<br>Instruction  | DDRVA                   |
| Execution<br>condition                                | Normally ON/OFF coil | Suitable<br>Models      | XC2, XC3, XC5, XCM, XCC |
| Hardware<br>requirement                               | -                    | Software<br>requirement | -                       |

### 2、Operands

| Operands | Function   | Type           |
|----------|--|----------------|
| S1       | Specify the output pulse value or soft components ID     | 16/32bit, BIN  |
| S2       | Specify the output pulse frequency or soft components ID | 16/32 bit, BIN |
| D1       | Specify the pulse output port                            | Bit            |
| D2       | Specify the pulse output direction port                  | Bit            |

### 3、suitable soft components

| Word | operands | system |    |    |    |    |    |    |    | constant | module |    |    |
|------|----------|--------|----|----|----|----|----|----|----|----------|--------|----|----|
|      |          | D      | FD | ED | TD | CD | DX | DY | DM | DS       | K/H    | ID | QD |
|      | S1       | •      | •  |    | •  | •  |    |    |    |          | •      |    |    |
|      | S2       | •      | •  |    | •  | •  |    |    |    |          | •      |    |    |

| Bit | operands | system |   |   |   |   |   |     |
|-----|----------|--------|---|---|---|---|---|-----|
|     |          | X      | Y | M | S | T | C | Dnm |
|     | D1       |        | • |   |   |   |   |     |
|     | D2       |        | • |   |   |   |   |     |

## Functions And Actions

《16 bit instruction form》

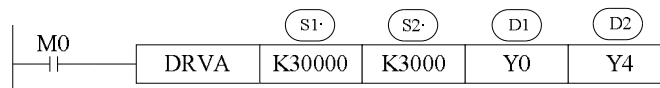

《32 bit instruction form》

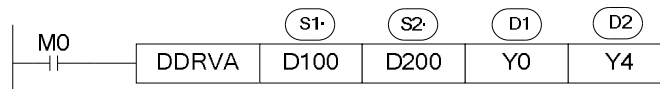

(Y0: [D8171, D8170], Y1: [D8174, D8173])

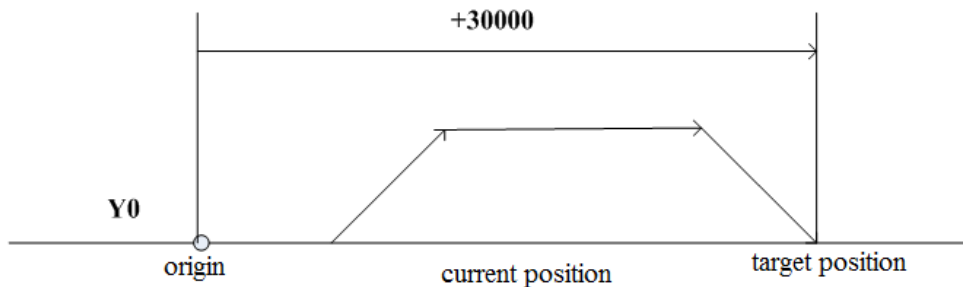

- Pulse output ID: only Y0 or Y1; XC5 series is Y0~Y3, 3 axis is Y0~Y2, 10 axis is Y0~Y11
- Pulse output direction can specify any Y;
- Acceleration/deceleration time is specified by D8230 (single word)
- The relative drive form means: move from the origin position (the position from origin to target position);
- Confirm the value of current position registers (D8171, D8170[Y0]/ D8174, D8173[Y1] .....)

**Example**

The current position of X axis is (100, 0), it will move to target position (3000, 0) at the speed of 1000Hz, pulse output terminal is Y0, direction terminal is Y4. The distance between origin and target position is 3000. The DRVA executing diagram is shown as below:

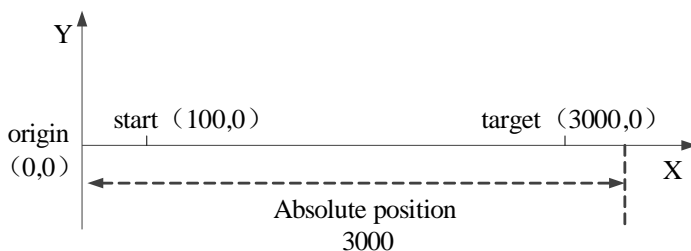

Program:

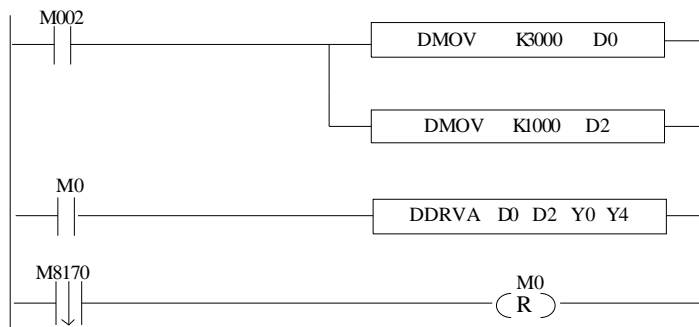

## 6-2-10. Absolute position multi-segment pulse control [PLSA]

PLSA/DPLSA has two control modes, below we will introduce one by one;

### Mode 1: uni-directional pulse output PLSA

#### 1、Instruction Summary

Generate absolute position segmented pulse with the specified frequency, acceleration/deceleration time and pulse direction;

| Absolute position multi-segment pulse control [PLSA] |                      |                         |                         |
|--|----------------------|-------------------------|-------------------------|
| 16 bits<br>Instruction                               | PLSA                 | 32 bits<br>Instruction  | DPLSA                   |
| Execution<br>condition                               | Normally ON/OFF coil | Suitable<br>Models      | XC2, XC3, XC5, XCM, XCC |
| Hardware<br>requirement                              | -                    | Software<br>requirement | -                       |

#### 2、Operands

| Operands | Function  | Type           |
|----------|---|----------------|
| S1       | Specify the soft component's number to output the pulse parameters    | 16/32bit, BIN  |
| S2       | Specify the acceleration/deceleration time or soft component's number | 16/32 bit, BIN |
| D        | Specify the pulse output port   | Bit            |

#### 3、suitable soft components

|      |          |        |    |    |    |    |    |     |    |          |        |    |    |
|------|----------|--------|----|----|----|----|----|-----|----|----------|--------|----|----|
| Word | operands | system |    |    |    |    |    |     |    | constant | module |    |    |
|      |          | D      | FD | ED | TD | CD | DX | DY  | DM | DS       | K/H    | ID | QD |
|      | S1       | •      | •  |    | •  | •  |    |     |    |          |        |    |    |
|      | S2       | •      | •  |    | •  | •  |    |     |    |          | K      |    |    |
| Bit  | operands | system |    |    |    |    |    |     |    |          |        |    |    |
|      |          | X      | Y  | M  | S  | T  | C  | Dnm |    |          |        |    |    |
|      | D1       |        | •  |    |    |    |    |     |    |          |        |    |    |

## Functions And Actions

《16 bit instruction form》

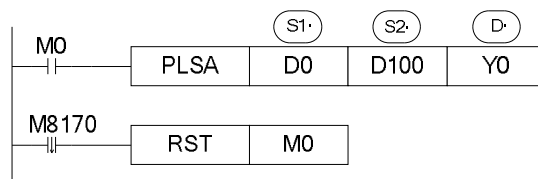

《32 bit instruction form》

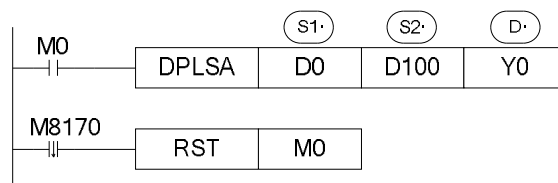

- The parameters' address is a section starts from **Dn** or **FDn**. In the above example: **D0** set the first segment pulse's highest frequency, **D1** set the first segment's absolute position, **D2** set the second segment pulse's highest frequency, **D3** set the second segment's absolute position, ..... if the set value in **Dn**, **Dn+1** is 0, this represents the end of segment, we can set 24 segments in total;
- For 32 bits instruction DPLSA, D0, D1 set the first segment pulse highest frequency, D2,D3 set the first segment pulse quantity, D4, D5 set the second segment pulse highest frequency, D6,D7 set the second segment pulse quantity..... If the setting value of **Dn**, **Dn+1**, **Dn+2**, **Dn+3** are 0, it means the end of the segment. It can set 24 segments in total.
- Acceleration/deceleration time is the time from the start to the first segment's highest frequency. Meantime, it defines the slope of all segment's frequency to time. In this way the following acceleration/deceleration will perform according to this slope.
- Pulse can be output at only Y0 or Y1; XC5 series is Y0~Y3, 3 axis is Y0~Y2, 10 axis is Y0~Y11;
- Frequency range: 0~32767Hz (16 bits instruction), 0~200KHz (32 bits instruction)
- Pulse number range: K0~K32,767 (16 bits instruction), K0~K2,147,483,647 (32 bits instruction)
- Confirm the value in current position registers (D8171, D8170[Y0]/ D8174, D8173[Y1] .....

Note: if the segment quantity is n, the address of the segments must be continuous, and the pulse frequency and quantity of n+1 segment must be 0. It means the pulse output end. The address of acceleration/deceleration time cannot follow the segment n.

**Example**

Output 6 segments of pulse through instruction DPLSA. Y0 is pulse output terminal.

| Name                           | Frequency (Hz) | Absolution position |
|--------------------------------|----------------|---------------------|
| Segment 1                      | 1000           | 2000                |
| Segment 2                      | 200            | 3000                |
| Segment 3                      | 3000           | 9000                |
| Segment 4                      | 800            | 10600               |
| Segment 5                      | 100            | 11400               |
| Segment 6                      | 1200           | 14400               |
| Acceleration/deceleration time | 100ms          |                     |

Use 32 bits instruction DPLSA:

| Name                           | Frequency (Hz) | Frequency address (Dword) | Absolution position | Absolution position address (Dword) |
|--------------------------------|----------------|---------------------------|---------------------|-------------------------------------|
| Segment 1                      | 1000           | D1、D0                     | 2000                | D3、D2                               |
| Segment 2                      | 200            | D5、D4                     | 3000                | D7、D6                               |
| Segment 3                      | 3000           | D9、D8                     | 9000                | D11、D10                             |
| Segment 4                      | 800            | D13、D12                   | 10600               | D15、D14                             |
| Segment 5                      | 100            | D17、D16                   | 11400               | D19、D18                             |
| Segment 6                      | 1200           | D21、D20                   | 14400               | D23、D22                             |
| Acceleration/deceleration time | 100ms          |                           | D51、D0              |                                     |

**Note:** the 4 registers after segment 6 must be 0. (D27, D26, D25, D24).It means the pulse output end. For 16 bits instruction PLSA, 2 registers after segment 6 must be 0.

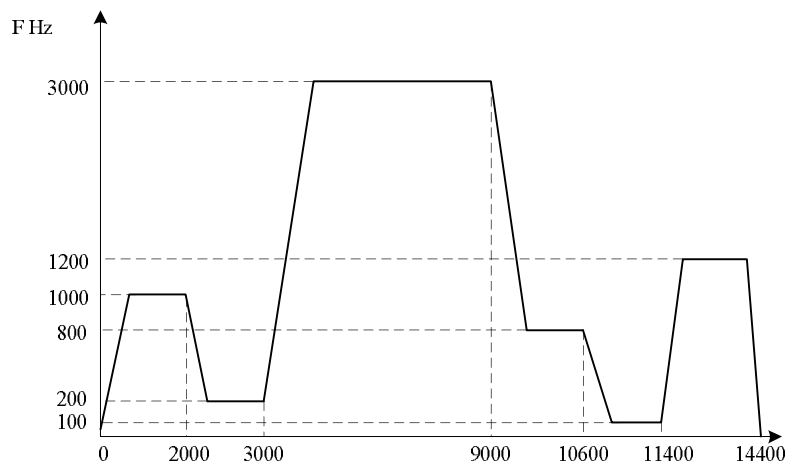

Program:

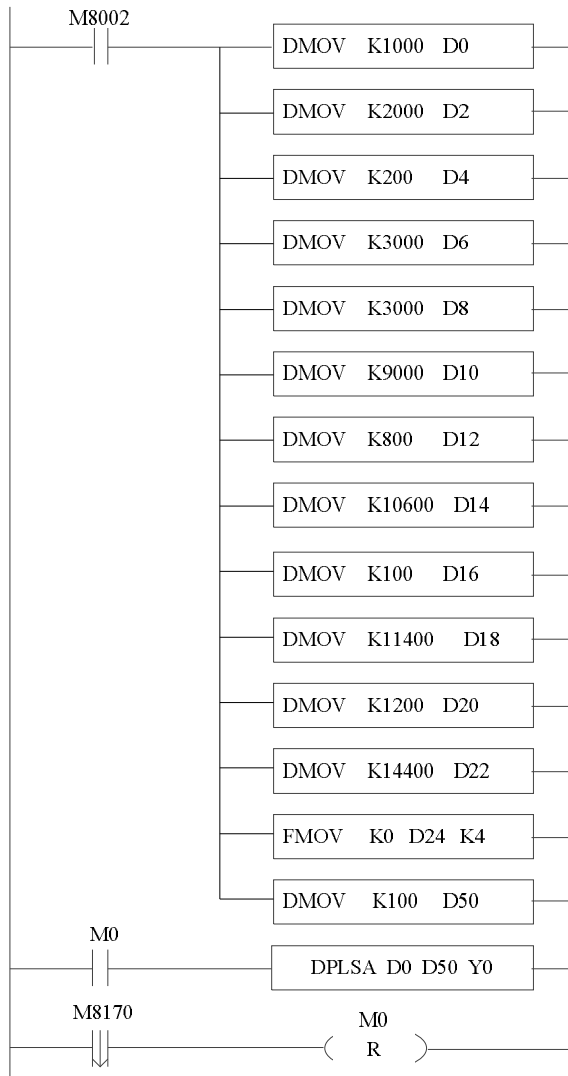

### ➤ Mode2: dual-directional pulse output PLSA

#### 1、Instruction Summary

Generate absolute position pulse with the specified frequency, acceleration/deceleration time and pulse direction;

| Absolute position multi-segment pulse control [PLSA] |                      |                        |                         |
|--|----------------------|------------------------|-------------------------|
| 16 bits<br>Instruction                               | PLSA                 | 32 bits<br>Instruction | DPLSA                   |
| Execution condition                                  | Normally ON/OFF coil | Suitable Models        | XC2, XC3, XC5, XCM, XCC |
| Hardware requirement                                 | -                    | Software requirement   | -                       |

## 2、 Operands

| Operands | Function  | Type           |
|----------|---|----------------|
| S1       | Specify the soft component's number to output the pulse parameters    | 16/32bit, BIN  |
| S2       | Specify the acceleration/deceleration time or soft component's number | 16/32 bit, BIN |
| D1       | Specify the pulse output port   | Bit            |
| D2       | Specify the pulse direction port                                      | Bit            |

## 3、 suitable soft components

| Word | operands | system |    |    |    |    |    |    |    | constant | module |    |    |
|------|----------|--------|----|----|----|----|----|----|----|----------|--------|----|----|
|      |          | D      | FD | ED | TD | CD | DX | DY | DM | DS       | K/H    | ID | QD |
|      | S1       | •      | •  |    | •  | •  |    |    |    |          |        |    |    |
|      | S2       | •      | •  |    | •  | •  |    |    |    | K        |        |    |    |

| Bit | operands | system |   |   |   |   |   |     |
|-----|----------|--------|---|---|---|---|---|-----|
|     |          | X      | Y | M | S | T | C | Dnm |
|     | D1       |        | • |   |   |   |   |     |
|     | D2       |        | • |   |   |   |   |     |

## Functions And Actions

《16 bit instruction form》

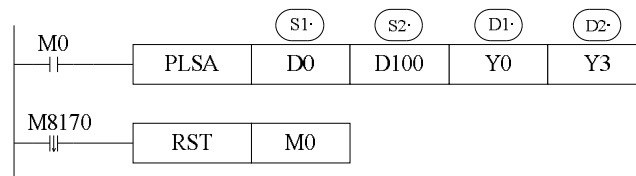

《32 bit instruction form》

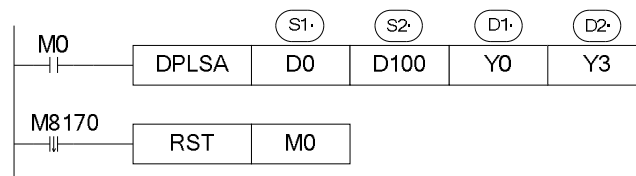

- The parameters' address is a section starts from **Dn** or **FDn**. In the above example: **D0** set the first segment pulse's highest frequency, **D1** set the first segment's absolute position, **D2** set the second segment pulse's highest frequency, **D3** set the second segment's absolute position, ..... if the set value in **Dn**, **Dn+1** is 0, this represents the end of segment, we can set 24 segments in total;

- For 32 bits instruction DPLSA. The parameters' address is a section starts from **Dn** or **FDn**. In the above example: **D0,D1** set the first segment pulse's highest frequency, **D2,D3** set the first segment's absolute position, **D4,D5** set the second segment pulse's highest frequency, **D6,D7** set the second segment's absolute position, ..... if the set value in **Dn,Dn+1,Dn+2,Dn+3** is 0, this represents the end of segment, we can set 24 segments in total;
- Acceleration/deceleration time is the time from the start to the first segment's highest frequency. Meantime, it defines the slope of all segment's frequency to time. In this way the following acceleration/deceleration will perform according to this slope.
- Pulse can be output at only Y0 or Y1, XC5 series is Y0~Y3, 3 axis is Y0~Y2, 10 axis is Y0~Y11.
- Frequency range: 0~32767Hz (16 bits instruction), 0~200KHz (32 bits instruction)
- Pulse number range: K0~K32,767 (16 bits instruction), K0~K2,147,483,647 (32 bits instruction)
- Confirm the value in current position registers (D8171, D8170[Y0]/ D8174, D8173[Y1] .....)
- The Y port to output the pulse direction can be set freely;

**Note:** when PLSA and DPLSA have several segments, the direction of these segments must be the same.

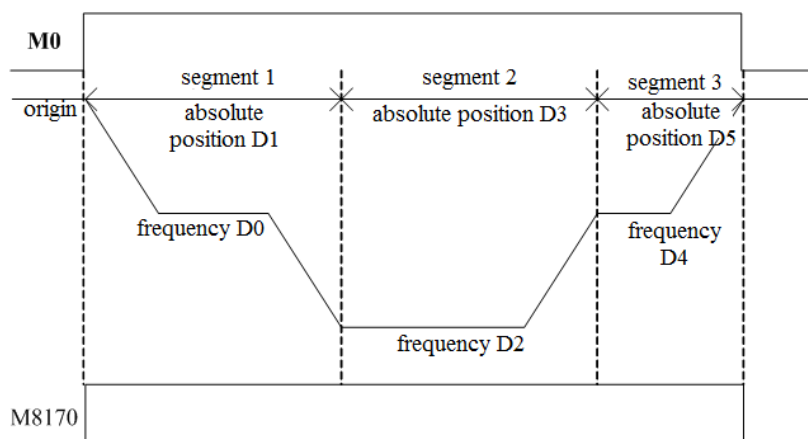

### Example

Output 6 segments of pulse through instruction DPLSA. The pulse terminal is Y0, direction terminal is Y2.

| Name                           | Frequency (Hz) | Absolution position |
|--------------------------------|----------------|---------------------|
| Segment 1                      | 1000           | 2000                |
| Segment 2                      | 200            | 3000                |
| Segment 3                      | 3000           | 9000                |
| Segment 4                      | 800            | 10600               |
| Segment 5                      | 100            | 11400               |
| Segment 6                      | 1200           | 14400               |
| Acceleration/deceleration time | 100ms          |                     |

Use 32 bits instruction DPLSA:

| Name                                  | Frequency (Hz) | Frequency address (Dword) | Absolution position | Absolution position (Dword) |
|---------------------------------------|----------------|---------------------------|---------------------|-----------------------------|
| Segment 1                             | 1000           | D1、D0                     | 2000                | D3、D2                       |
| Segment 2                             | 200            | D5、D4                     | 3000                | D7、D6                       |
| Segment 3                             | 3000           | D9、D8                     | 9000                | D11、D10                     |
| Segment 4                             | 800            | D13、D12                   | 10600               | D15、D14                     |
| Segment 5                             | 100            | D17、D16                   | 11400               | D19、D18                     |
| Segment 6                             | 1200           | D21、D20                   | 14400               | D23、D22                     |
| Acceleration/<br>deceleration<br>time | 100ms          |                           | D51、D0              |                             |

Note: the 4 registers after segment 6 must be 0. (D27、D26、D25、D24). It means the pulse output end. For 16 bits instruction PLSA, the 2 registers after segment 6 must be 0.

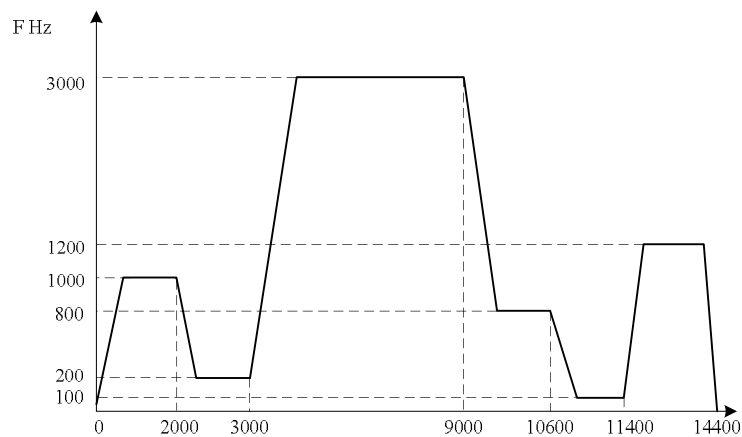

Program:

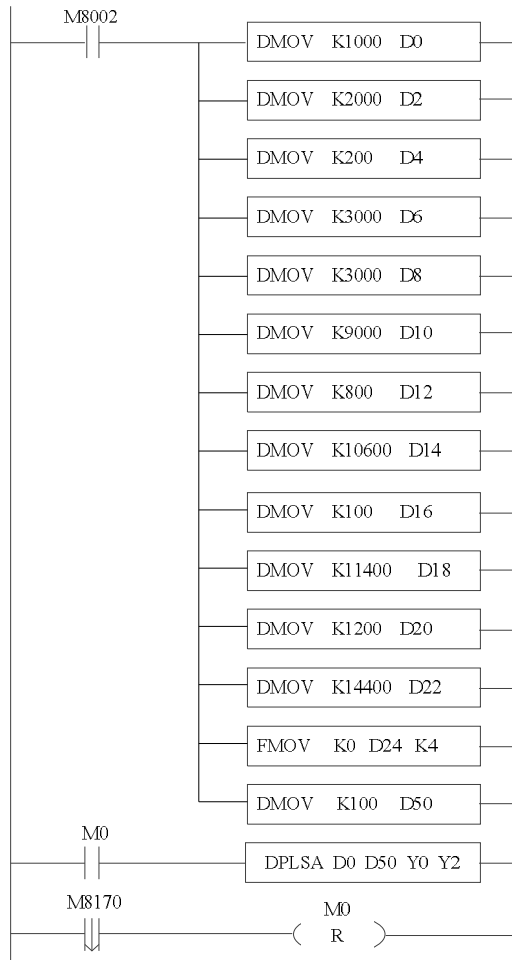

### 6-2-11. Relative position multi-section pulse control [PTO]

#### 1、 Summary

Produce relative position multi-section pulse as setting parameters.

| Relative position multi-section pulse control [PTO] |                 |                 |                 |
|---|-----------------|-----------------|-----------------|
| 16 bits   | -               | 32 bits         | PTO             |
| Execution condition                                 | Edge triggering | Suitable models | XC3、XC5、XCM、XCC |
| Hardware  | V3.3 and higher | Software        | V3.3 and higher |

#### 2、 Operand

| Operands | Function   | Type         |
|----------|--|--------------|
| S1       | Soft element head address of output pulse parameters | 32 bits, BIN |
| S2       | External interruption input port no.                 | Bit          |

|    |                                 |     |
|----|---------------------------------|-----|
| D1 | Pulse output port no.           | Bit |
| D2 | Pulse output direction port no. | Bit |

## 3、Suitable soft element

|      |              |        |    |    |    |    |    |     |    |               |        |    |
|------|--------------|--------|----|----|----|----|----|-----|----|---------------|--------|----|
| Word | Oper-<br>and | System |    |    |    |    |    |     |    | Const<br>-ant | Module |    |
|      |              | D      | FD | ED | TD | CD | DX | DY  | DM | DS            | K/H    | ID |
|      | S1           | •      |    |    | •  | •  |    |     |    |               |        |    |
| Bit  | Oper-<br>and | System |    |    |    |    |    |     |    |               |        |    |
|      |              | X      | Y  | M  | S  | T  | C  | Dnm |    |               |        |    |
|      |              | S2     | •  |    |    |    |    |     |    |               |        |    |
|      |              | D1     |    | •  |    |    |    |     |    |               |        |    |
|      | D2           |        | •  |    |    |    |    |     |    |               |        |    |

PTO instruction has two control modes.

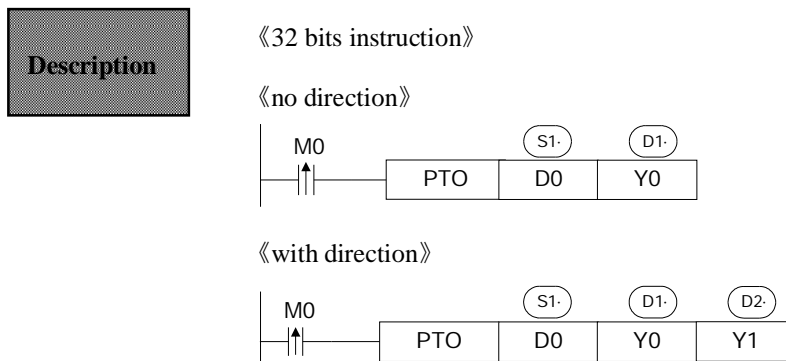
**Mode1: PTO without external interruption**

Parameters distribution: (the parameters are 32 bits 2 bytes):

- S1 : section quantity N, range 1~255
- S1+2 : reserved
- S1+4 : pulse direction, 0 is positive direction; 1 is negative direction  
Among each section, only one section pulse quantity can be 0.
- S1+6 : Pulse falling slope, which is decreasing frequency per second. 0 means urgent stop.
- S1+8 : start frequency of section 1
- S1+10: end frequency of section 1
- S1+12: pulse quantity of section 1

- S1+14: start frequency of section 2
- S1+16: end frequency of section 2
- S1+18: pulse quantity of section 2
- S1+20: start frequency of section 3
- S1+22: end frequency of section 3
- S1+24: pulse quantity of section 3
- .....
- and so on, user can set section N parameters

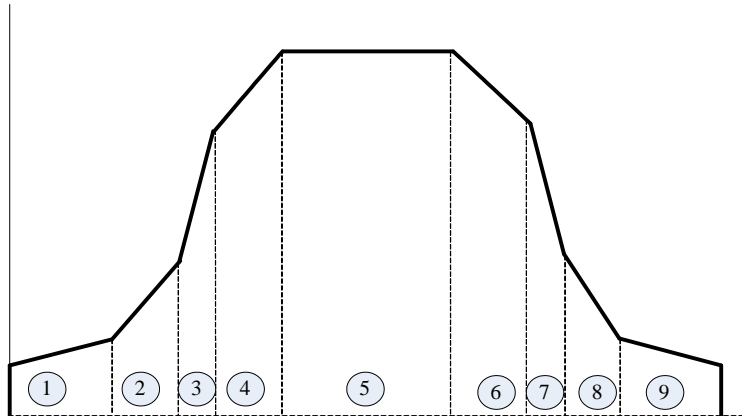

- The parameters address starts from Dn or FDn  
In the above example:(D1,D0) is pulse section quantity;(D5,D4)is pulse direction; (D7,D6) is pulse falling frequency;(D9,D8)is start frequency of section 1;(D11,D10)is end frequency of section 1; (D13, D12) is the pulse quantity of section 1. The max section quantity can be 255.
- Pulse output: Y0, Y1; the pulse output terminal is different for each model.
- If pulse quantity of section m is 0, this means the pulse quantity is unlimited.
- If pulse quantity of section m is 0, the start frequency must be equal to the end frequency; otherwise this section will not be executed.
- If pulse quantity is not 0, the pulse direction is decided by the positive/negative of pulse. If the pulse quantity is 0, the pulse direction is set through S1+4.
- S1+6 is the slow stop slope when executing PSTOP (refer to PSTOP instruction).
- Pulse parameters occupy the register size:  $[(N*3+4) + (N*3+4) + (N*4+5)]*2$ .
- The instruction is executed at the rising edge; if the signal is normally close, the instruction will be executed repeatedly.

### Example

Continuous output 9 sections of pulses, the pulse output terminal is Y0, pulse direction terminal is Y2, the start frequency and end frequency please see the following table:

| Section | Start frequency<br>(Hz) | End frequency<br>(Hz) | Relative pulse<br>quantity |
|---------|-------------------------|-----------------------|----------------------------|
| 1       | 1000                    | 1500                  | 3000                       |

|   |      |      |       |
|---|------|------|-------|
| 2 | 1500 | 3200 | 3200  |
| 3 | 3200 | 6000 | 2000  |
| 4 | 6000 | 8000 | 10000 |
| 5 | 8000 | 8000 | 18000 |
| 6 | 8000 | 6000 | 10000 |
| 7 | 6000 | 3200 | 2000  |
| 8 | 3200 | 1500 | 3200  |
| 9 | 1500 | 1000 | 3000  |

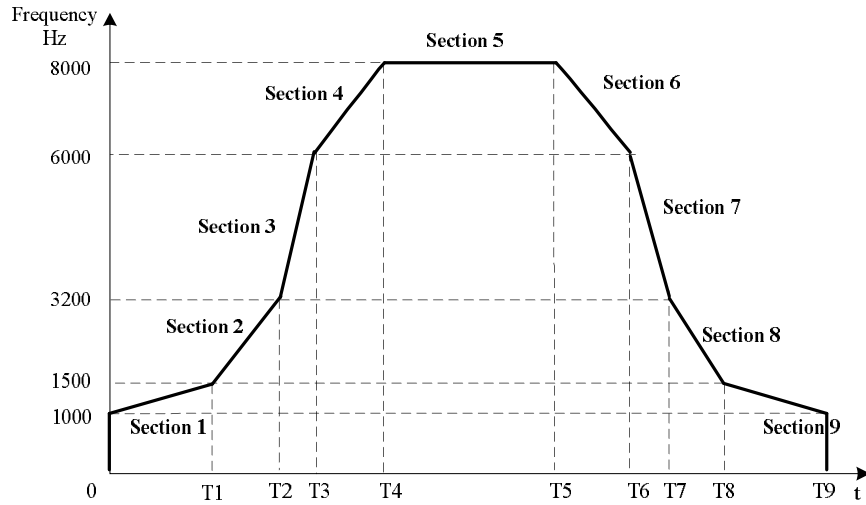

Ladder chart:



Set the parameters:

Set the parameters through PTO config . Please find it in XCPpro software.

PTO Config

Instruction: PTO With Direction

Reg Block Addr: D4000 Output: Y0 Direction: Y2

Decreasing Frequency: 0 Pulse unlimit Direction: +



Add Edit Delete Upwards Downwards

|  | Num | Start Frequency | End Frequency | Pulse Count |
|--|-----|-----------------|---------------|-------------|
|  | 1   | 1000            | 1500          | 3000        |
|  | 2   | 1500            | 3200          | 3200        |
|  | 3   | 3200            | 6000          | 2000        |
|  | 4   | 6000            | 8000          | 10000       |

Used: D4000 - D4205 Read From PLC Write To PLC OK Cancel

Note:

(1) PTO parameters will occupy the registers of D4000~D4205, please don't use these registers for other purpose.

(2) Click "Write to PLC" / OK. Then click stop , run .

**Mode2: PTO with external interruption****Description**

《32 bits instruction》

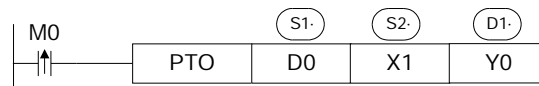

Parameter distribution (the parameter is 32 bits, 2 bytes):

- S1 : section quantity N, range 1~255
- S1+2 : reserved
- S1+4 : pulse direction (the section of 0 pulses), 0 is positive direction, 1 is negative direction
- S1+6 : pulse falling slope, decreasing frequency per second, 0 is urgent stop
  
- S1+8 : start frequency of section 1
- S1+10: end frequency of section 1
- S1+12: pulse quantity of section 1
  
- S1+14: start frequency of section 2
- S1+16: end frequency of section 2
- S1+18: pulse quantity of section 2
  
- S1+20: start frequency of section 3
- S1+22: end frequency of section 3
- S1+24: pulse quantity of section 3
- .....
- And so on, user can set the parameters of section N

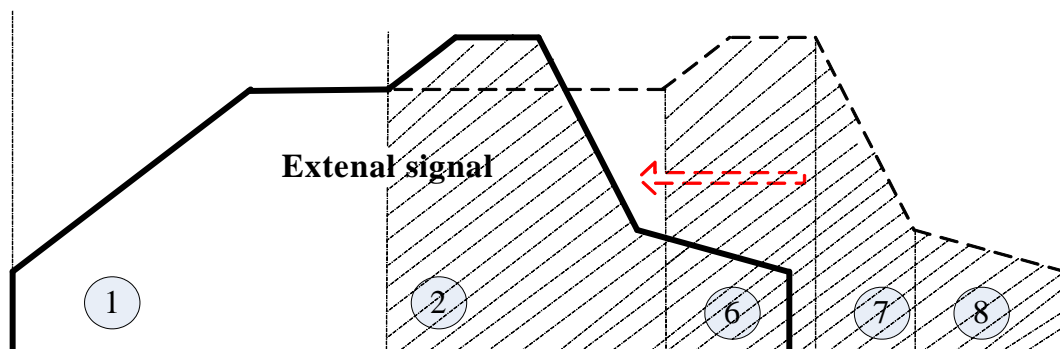

- If user has not set the 0 pulse section, the instruction will not be executed.
- If the external signal is produced in zero pulse section, it will switch to the next section (if there is no next section, stop the pulse output).
- If the external signal is produced in non-zero pulse section, it will run the rest pulses with the set slope (S1+6 parameter); if the rest pulses is larger than the pulse quantity of frequency falling section, it will run a smooth section and then the falling section.
- S1+6 are the urgent stop slope when running PSTOP instruction.
- Cannot support absolute position instruction, cannot support instruction with direction.

- The instruction will be executed at the rising edge; if it is normally close signal, the instruction will be executed repeatedly.

The instruction execution in different conditions:

- The external interruption signal is produced in zero pulse section.

The instruction will switch to the next section when encountering the external interruption signal,  $S_s = S_3 + S_4 + S_5$ .

$S_3$  is section 3 pulse quantity.

$S_4$  is section 4 pulse quantity.

$S_5$  is section 5 pulse quantity.

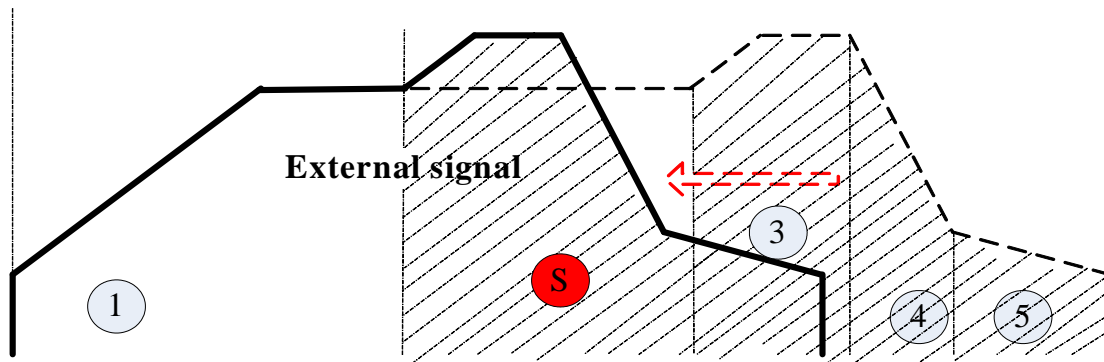

- External interruption signal is produced in non-zero pulse section, rest pulses  $S_s$  is larger than falling pulses  $S_n$ .

When encountering the external interruption signal, it runs the smooth section with the current frequency  $S_m = S_s - S_n$ , then the falling section  $S_n$ .

$S_s$  is pulses of rest section.

$S_n$  is pulses of frequency falling section when encountering external interruption signal.

$S_m$  is pulses of smooth section when encountering the external interruption signal.

$S_6$  is the pulses of section 6

$S_7$  is the pulses of section 7

$S_8$  is the pulses of section 8

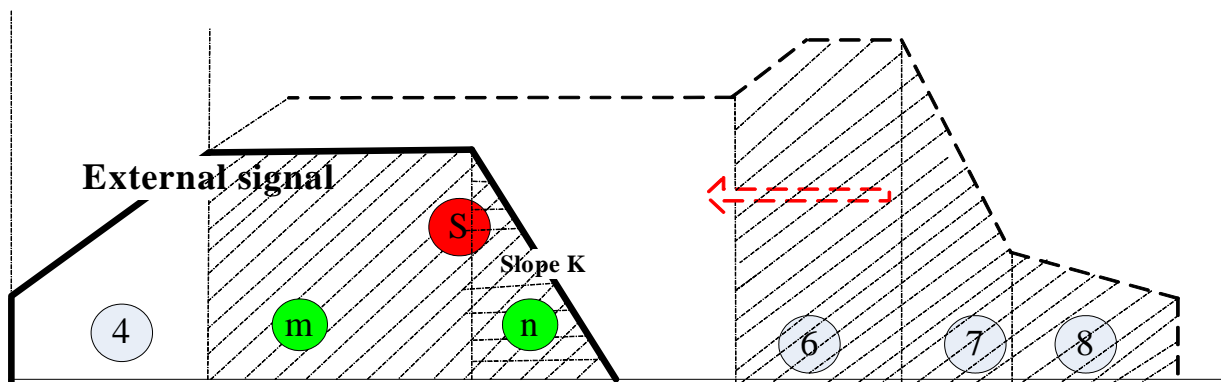

- The external interruption signal is produced in the non-zero pulse section. The rest pulses  $S_s$  is smaller than falling section pulses  $S_n$ .

When encountering the external interruption signal, it runs the falling section with the slope K.

When  $S_s = S_6 + S_7$ , it stops outputting the pulses.

$S_s$  is the pulses of rest section.

$S_6$  is the pulses of section 6.

$S_7$  is the pulses of section 7.

$S_n$  is the pulses of falling section when encountering the external interruption signal.

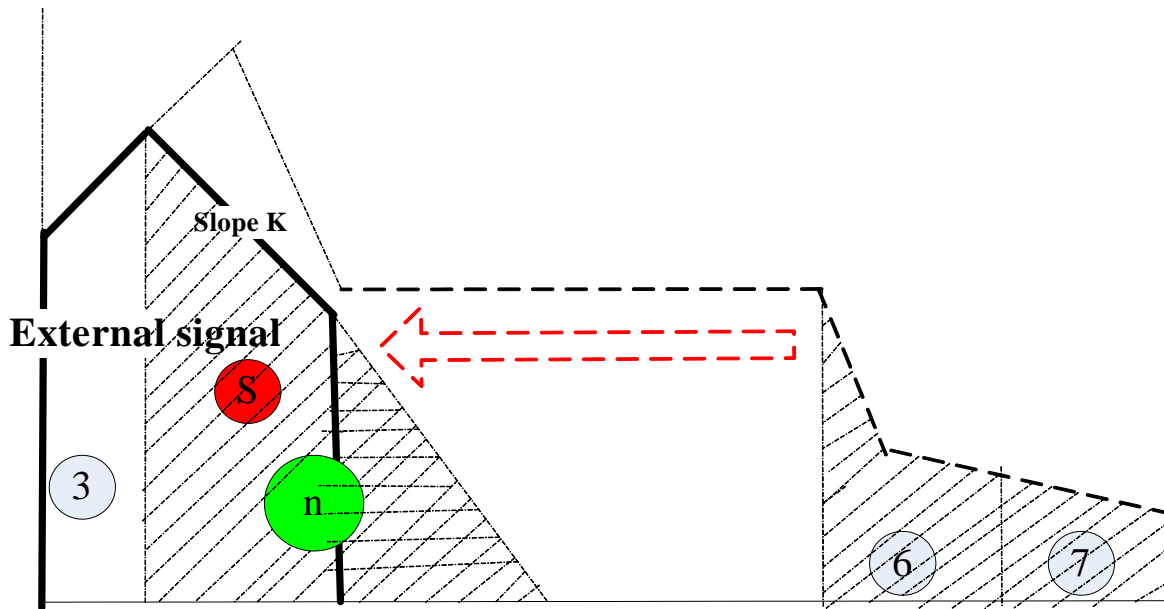

$S_1 + 6 = 0$ , the pulse will stop after running the smooth section.

$S_m = S_6 + S_7 + S_8$

- The external interruption signal is produced in non-zero pulse section, rest pulses  $S_s$  is smaller than falling section pulses  $S_n$ .
- If encountering the external interruption signal, it runs the falling pulses with slope K, when  $S_s = S_6 + S_7$ , it stop outputting the pulses.
  - $S_s$  is the rest section pulses.
  - $S_6$  is the pulses of section 6.
  - $S_7$  is the pulses of section 7.
  - $S_n$  is the falling section pulses when encountering the external interruption signal.

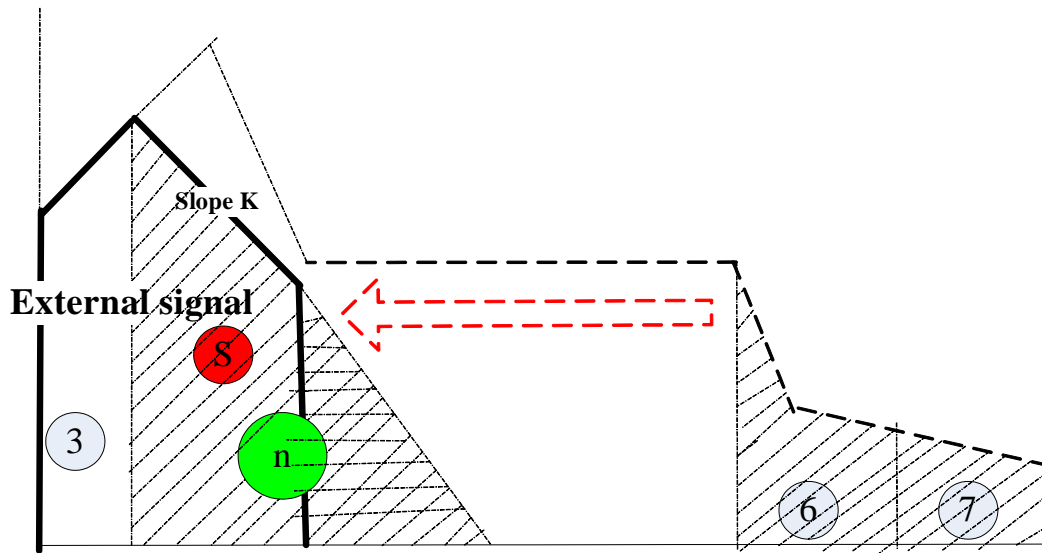

### 6-2-12. Absolute position multi-section pulse control [PTOA]

#### 1、 Summary

Section to produce pulse instructions of absolute position according to specified parameters

| Absolute position multi-section pulse control [PTOA] |                         |                      |                         |
|--|-------------------------|----------------------|-------------------------|
| 16 bits Instruction                                  | -                       | 32 bits Instruction  | PTOA                    |
| Execution condition                                  | Edge triggering         | Suitable Models      | XC3、XC5、XCM、XCC         |
| Hardware requirement                                 | V3.3 and higher version | Software requirement | V3.3 and higher version |

#### 2、 Operands

| Operands | Function   | Type        |
|----------|--|-------------|
| S1       | Specify the soft component's start ID of the output pulse parameters | 32bits, BIN |
| D1       | Specify the pulse output port  | Bit         |
| D2       | Specify the pulse output direction port                              | Bit         |

## 3、 Suitable soft components

|      |          |        |    |    |    |    |    |     |    |          |        |    |
|------|----------|--------|----|----|----|----|----|-----|----|----------|--------|----|
| Word | operands | System |    |    |    |    |    |     |    | constant | module |    |
|      |          | D      | FD | ED | TD | CD | DX | DY  | DM | DS       | K/H    | ID |
|      | S1       | •      | •  |    | •  | •  |    |     |    |          |        |    |
| Bit  | operands | System |    |    |    |    |    |     |    |          |        |    |
|      |          | X      | Y  | M  | S  | T  | C  | Dnm |    |          |        |    |
|      | D1       |        | •  |    |    |    |    |     |    |          |        |    |
|      | D2       |        | •  |    |    |    |    |     |    |          |        |    |

**Mode: PTOA (Fixed pulse quantity)****Description**

《32 bits instruction form》

《Without direction》

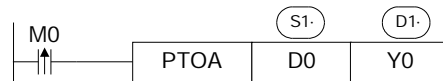

《With direction》

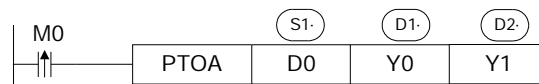

The parameters address and functions are shown as below (the parameter is 32 bits, two bytes):

- S1 : Total section N, range is 1~255
- S1+2 : reserved
- S1+4 : The direction(0 is positive,1 is negative) of unlimited pulse section (zero pulse section)
- S1+6 : Pulse descending slope, decreasing frequency per second, 0 means urgent stop
- S1+8 : Start pulse frequency of section 1
- S1+10: End pulse frequency of section 1
- S1+12: Absolute pulse position of section 1
- S1+14: Start pulse frequency of section 2
- S1+16: End pulse frequency of section 2
- S1+18: Absolute pulse position of section 2
- S1+20: Start pulse frequency of section 3
- S1+22: End pulse frequency of section 3
- S1+24: Absolute pulse position of section 3

.....

- The pulse parameters address of section N can be known by this discipline

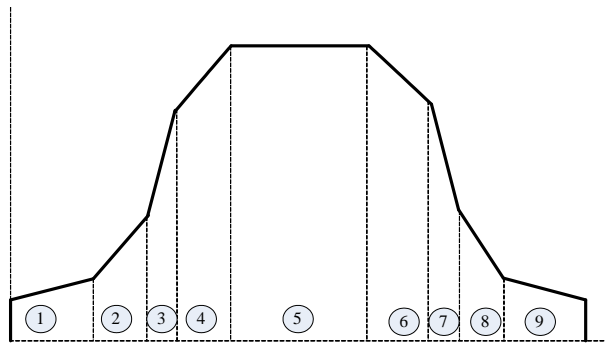

- The pulse direction of section 1 is decided by current pulse quantity and cumulative pulse quantity, other section directions are decided by current pulse quantity and last section pulse quantity;
- Occupied registers size:  $[(N*3+4)+(N*3+4)+(N*4+5)]*2$ ;
- The toggle condition to execute the pulse is rising edge, if the signal is closed signal the pulse will execute repeatedly.

#### Example

The pulse output terminal is Y0, direction terminal is Y2; The start, end frequency, pulse absolute position is shown in below table:

| Name      | Start Frequency(Hz) | End Frequency(Hz) | Absolute pulse quantity of each section |
|-----------|---------------------|-------------------|---|
| Section 1 | 1000                | 1500              | 3000                                    |
| Section 2 | 1500                | 3200              | 6200                                    |
| Section 3 | 3200                | 6000              | 8200                                    |
| Section 4 | 6000                | 8000              | 18200                                   |
| Section 5 | 8000                | 8000              | 36200                                   |
| Section 6 | 8000                | 6000              | 46200                                   |
| Section 7 | 6000                | 3200              | 48200                                   |
| Section 8 | 3200                | 1500              | 51400                                   |
| Section 9 | 1500                | 1000              | 54400                                   |

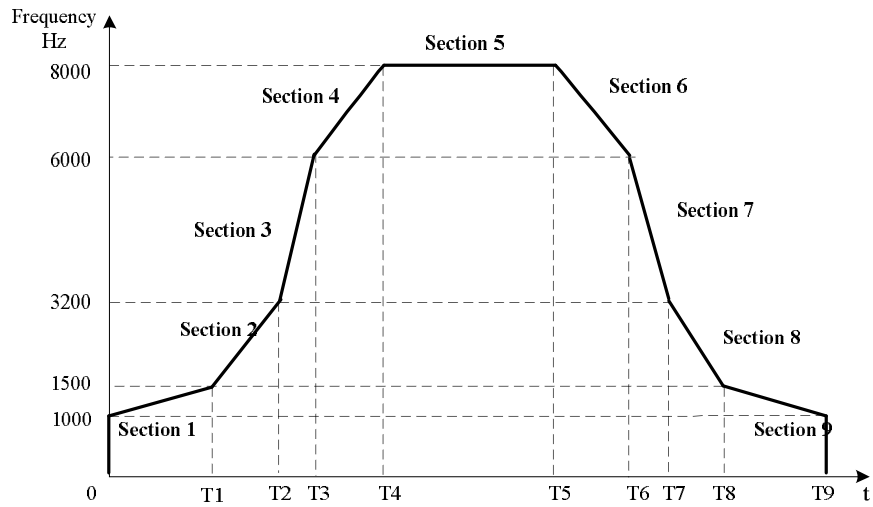

Ladder chart:



Set the parameters:

Fast configure the parameters through the PTO config function  in XCPpro software:

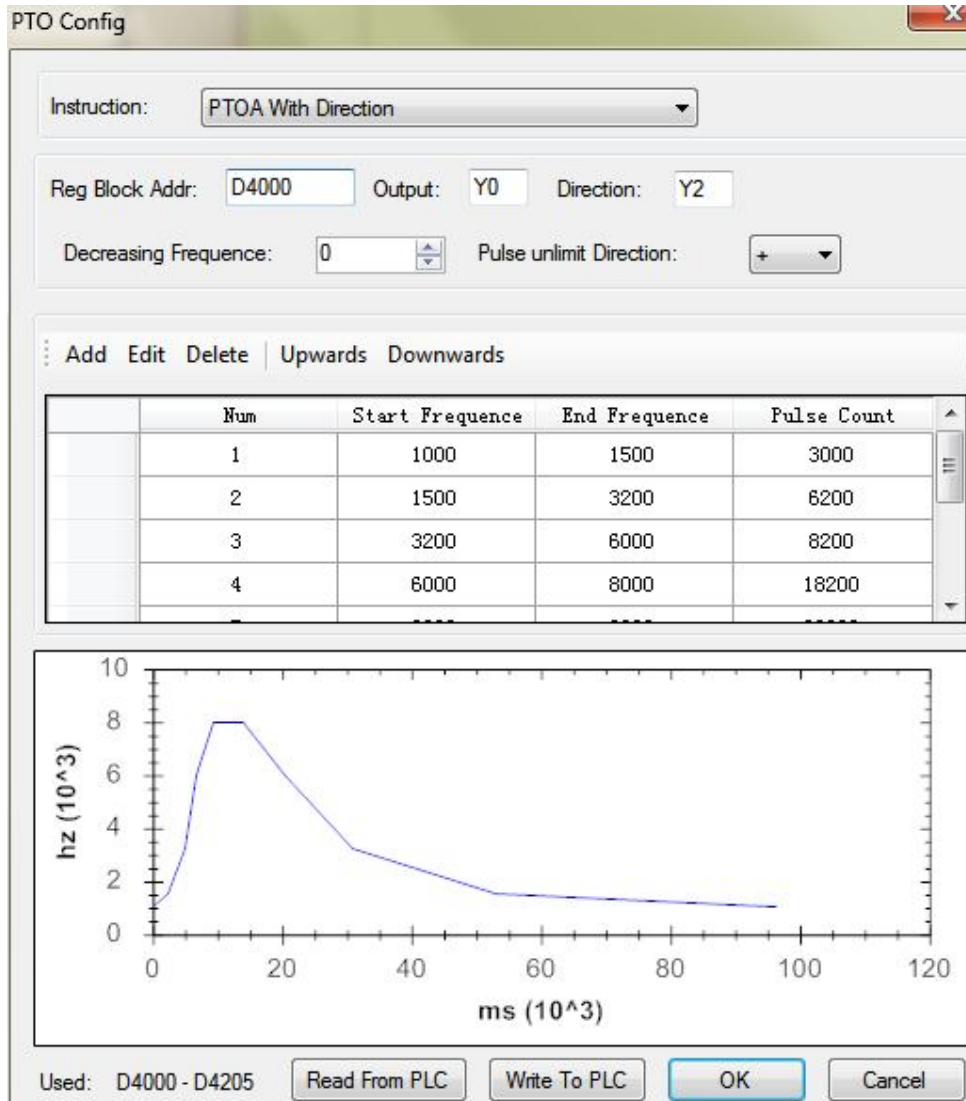

**Caution:** because the pulse instruction occupy the register address D4000~D5205, these register addresses can't be used for other purpose.

### 6-2-13. Pulse Stop [PSTOP]

#### 1、 Summary

Pulse stop instruction, execute with PTO instruction.

| Pulse Stop [PSTOP]   |                         |                      |                         |
|----------------------|-------------------------|----------------------|-------------------------|
| 16 bits Instruction  | -                       | 32 bits Instruction  | PSTOP                   |
| Execution condition  | Normally ON/OFF coil    | Suitable Models      | XC3、XC5、XCM、XCC         |
| Hardware requirement | V3.3 and higher version | Software requirement | V3.3 and higher version |

## 2、 Operands

| Operands | Function                       | Type       |
|----------|--------------------------------|------------|
| S1       | Specify pulse stop output port | bit        |
| S2       | Specify pulse stop mode data   | decimal, K |

## 3、 suitable soft components

| Word | Operands | System |    |    |    |    |    |    |    | constant | module |    |    |
|------|----------|--------|----|----|----|----|----|----|----|----------|--------|----|----|
|      |          | D      | FD | ED | TD | CD | DX | DY | DM | DS       | K/H    | ID | QD |
|      | S2       |        |    |    |    |    |    |    |    |          | •      |    |    |

| Bit | operands | System |   |   |   |   |   |     |
|-----|----------|--------|---|---|---|---|---|-----|
|     |          | X      | Y | M | S | T | C | Dnm |
|     | S1       |        | • |   |   |   |   |     |

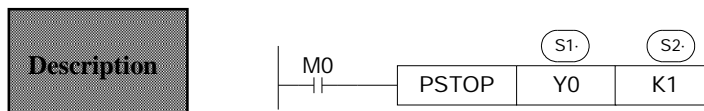

- This instruction is used to stop PTO pulse instruction.
- S2: Stop mode (urgent stop; slow stop).  
S2=K1, M0 is ON, pulses urgent stop.  
S2=K0, M0 is ON, pulses slow stop with the slope of PTO instruction parameter S1+6  
(If S1+6=0, it is urgent stop mode).

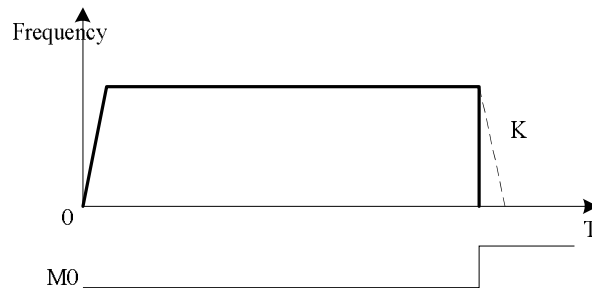

When M0 is ON, the solid line is urgent stop (K1), dotted line is slow stop.

## 6-2-14. Variable frequency single-section pulse [PTF]

### 1、 Summary

To produce the variable frequency pulses as set parameters:

| Variable frequency single section pulse output [PTF] |                        |                         |                        |
|--|------------------------|-------------------------|------------------------|
| 16 bits<br>Instruction                               | -                      | 32 bits<br>Instruction  | PTF                    |
| Execution<br>condition                               | Normally ON/OFF coil   | Suitable<br>Models      | XC3、XC5、XCM、XCC        |
| Hardware<br>requirement                              | V3.3 and higher vision | Software<br>requirement | V3.3 and higher vision |

### 2、 Operands

| Operands | Function  | Type         |
|----------|---|--------------|
| S1       | Specify the soft component start ID of the pulse parameters | 32 bits, BIN |
| D1       | Specify the pulse output port                               | Bit          |
| D2       | Specify the pulse output direction port                     | Bit          |

### 3、 Suitable soft components

| Word | operands | System |    |    |    |    |    |    |    | constant | module |    |    |
|------|----------|--------|----|----|----|----|----|----|----|----------|--------|----|----|
|      |          | D      | FD | ED | TD | CD | DX | DY | DM | DS       | K/H    | ID | QD |
|      | S1       | •      | •  |    | •  | •  |    |    |    |          |        |    |    |

  

| Bit | operands | System |   |   |   |   |   |     |
|-----|----------|--------|---|---|---|---|---|-----|
|     |          | X      | Y | M | S | T | C | Dnm |
|     | D1       |        | • |   |   |   |   |     |
|     | D2       |        | • |   |   |   |   |     |

### Description

《32 bits instruction》

《Without directions》

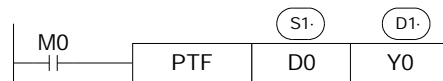

《With directions》

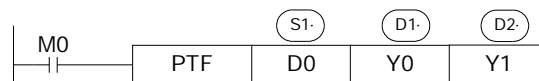

The parameters are shown as below (the parameters is 32 bits, two bytes):

- S1 : Pulse frequency
- S1+2 : Rising and falling frequency of pulse, which is increasing/decreasing frequency per second
- Pulse quantity in current section and cumulative pulses are not refreshed.
- Current pulse frequency is a target for every scanning period

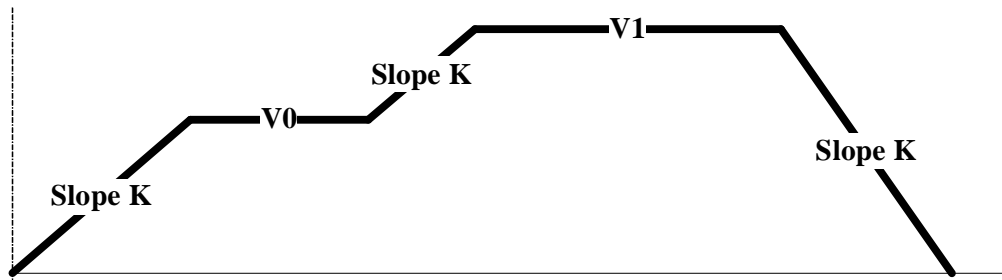

(A) The increasing pulses are 0 in unit time( $S1+2 = 0$ )

Pulse frequency will change as the slope K:

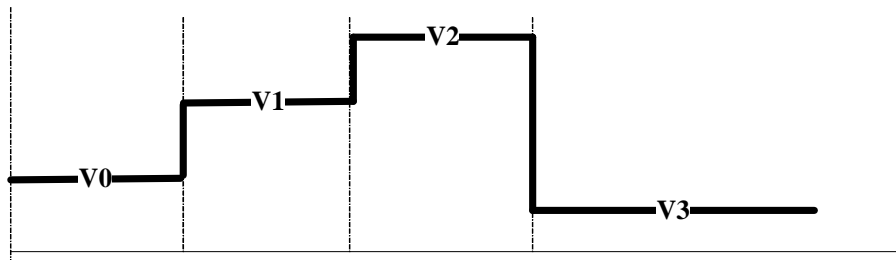

(B) The increase frequency quantity in unit time is not 0 (the parameter of S1+2 is not 0)

1) The pulse is in a smooth section when user set a new frequency, then the frequency will change to setting frequency through with the setting slope, please see the following diagram:

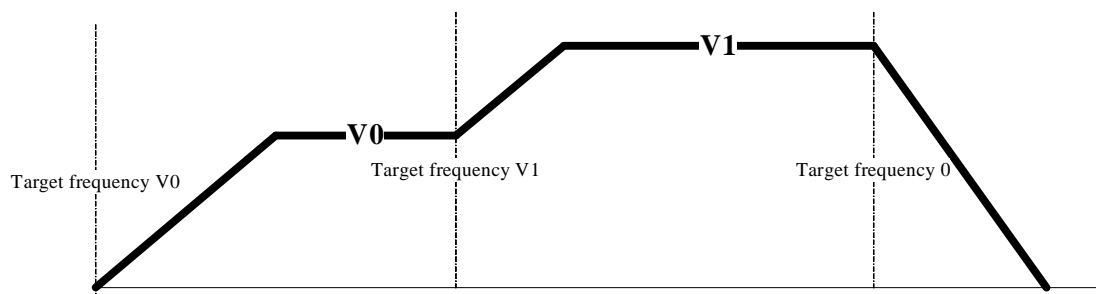

2) The pulse is in non-smooth section when user set a new frequency, then the frequency will change to setting frequency with setting slope (current setting frequency > last setting frequency, current setting frequency will be the target), please see the following diagram:

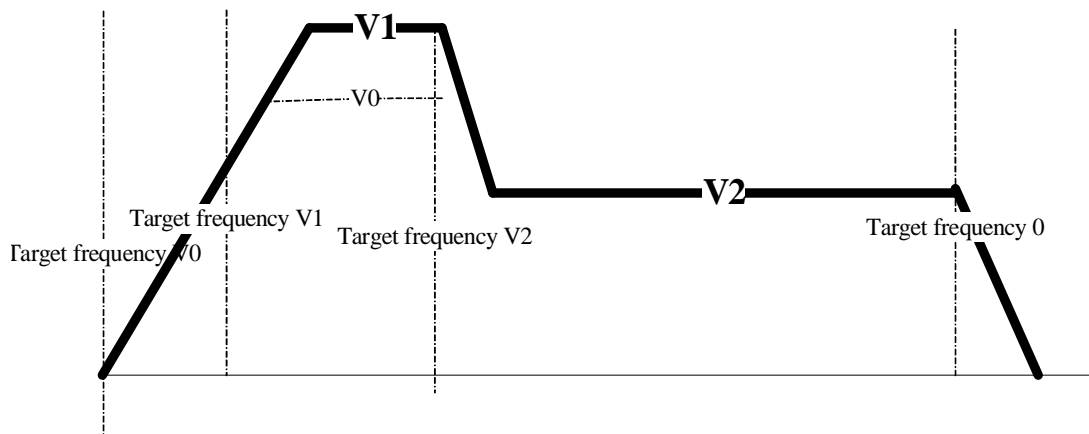

Before the frequency reaches  $V_0$ , user set the new target frequency  $V_1$  ( $V_1 > V_0$ ), then the frequency will turn to  $V_1$  according to the slope.

- 3) The pulse is in non-smooth section, when user set the new frequency, then change to setting frequency with the setting slope (Current setting frequency  $<$  last setting frequency, current setting frequency  $<$  current frequency), please see the following diagram:

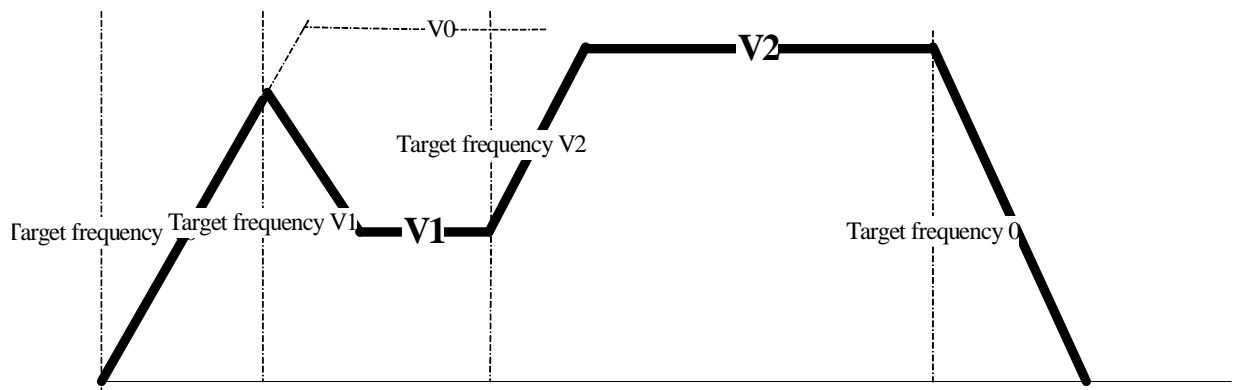

Before the frequency reaches  $V_0$ , user set the new target frequency  $V_1$  ( $V_1 < V_0$ ,  $V_1 <$  current frequency), it will go to the decreasing section until  $V_1$ , the slope is the same to the increasing section.

**6-3. Output Wiring**

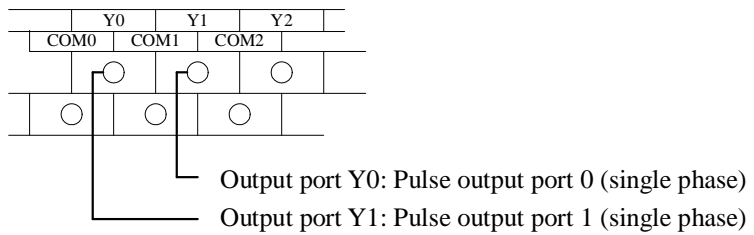

Below is the graph to show the output terminals and stepping driver wiring:

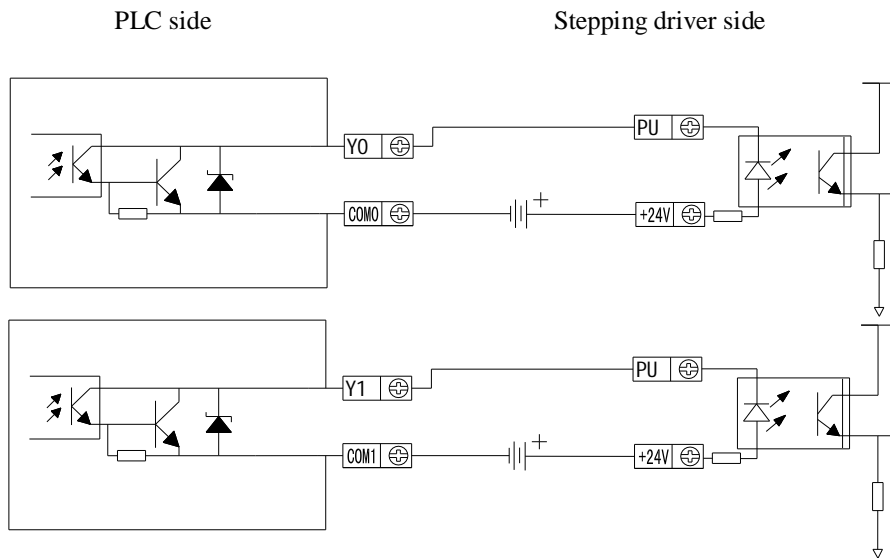

**6-4. Notes**

**1、 Concept of Step Frequency**

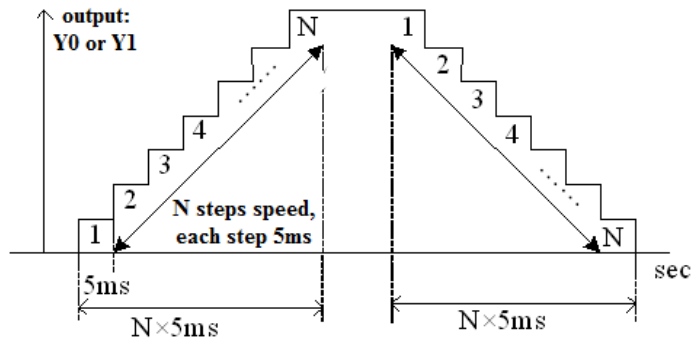

- During ACC/DEC, each step time is 5ms, this time is fixed and not changeable.
- The minimum step frequency (each step's rising/falling time) is 10Hz. If the frequency is lower than 10Hz, calculate as 10Hz; the maximum step frequency is 15Hz. If the frequency is larger than 15Hz, calculate as 15Hz;
- In case of frequency larger than 200Hz, please make sure each segment's pulse number no less than 10, if the set value is less than 10, send as 200Hz;

## 2、frequency jump in segment pulse output

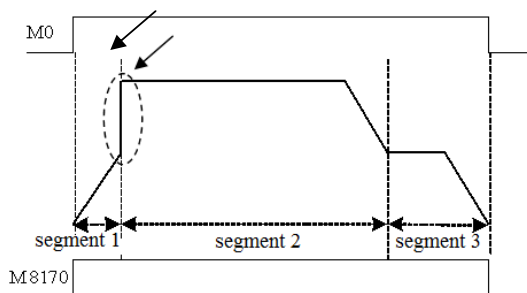

- When outputting the segmented pulse, if the current segment's pulse has been set out, while meantime it doesn't reach the highest frequency, then from the current segment to the next pulse output segment, pulse jump appears, see graph above;
- To avoid frequency jump, please set suitable acceleration/deceleration time.

## 3、dual pulse output is invalid

- In one main program, users can't write two or more pulse output instructions with one output port Y;
- The below sample is wrong;

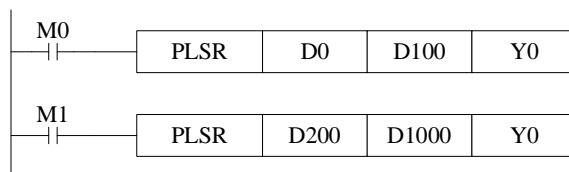

In the following cases, dual pulse output is invalid:

(1) in main program

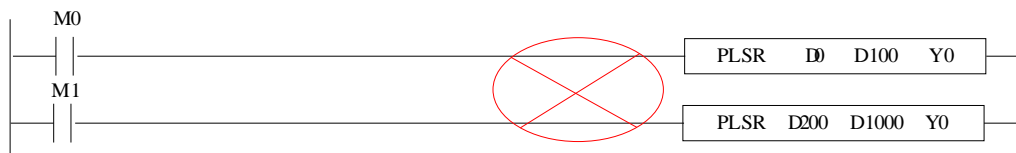

(2) in STL

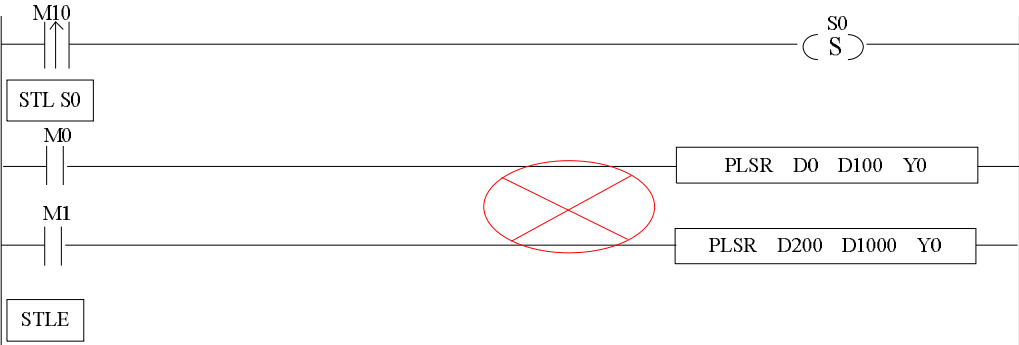

(3) in subprogram

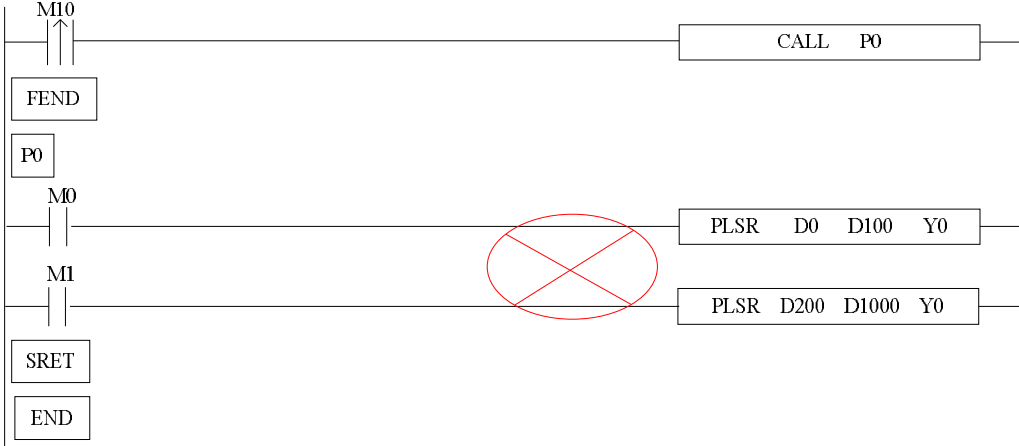

(4) one in main program, another in STL

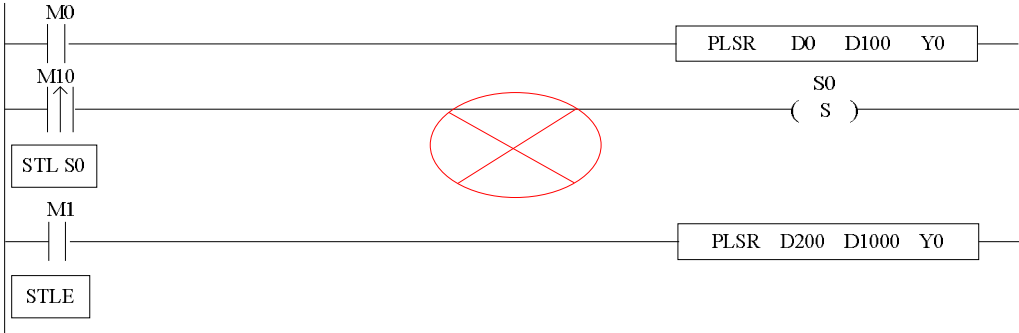

(5) one in main program, another in subprogram

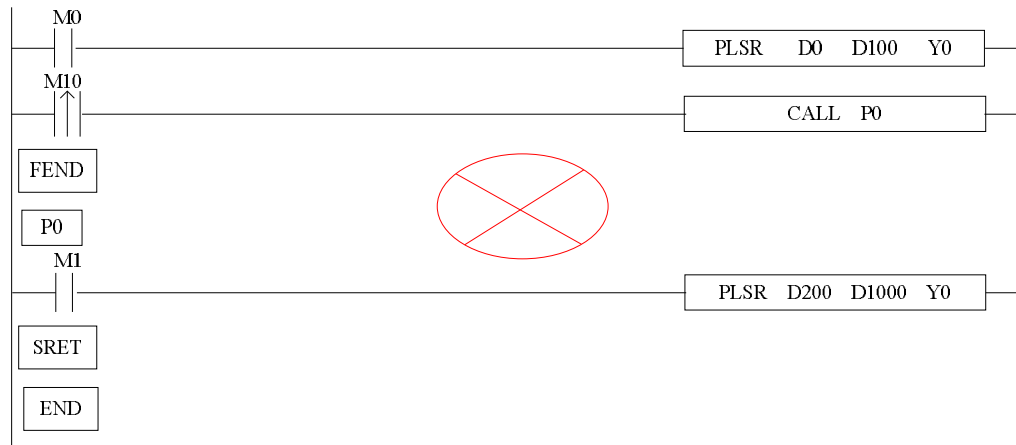

The correct programming method when it needs to write more than one pulse output instructions:

Method 1: use STL, each STL only write one pulse output instruction

Example:

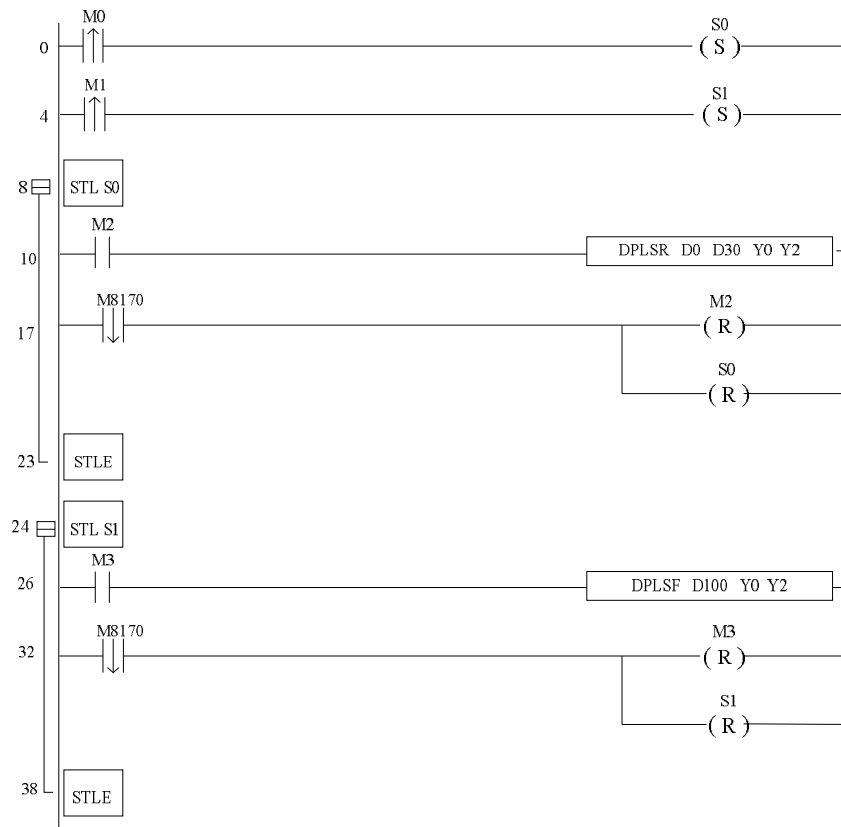

Note: the two STL cannot work at the same time! (M2 and M3 cannot be ON at the same time)

Method2: if the same instruction needs to work in many places of the program, user can write one instruction in the main program, and put its parameter registers in STL.

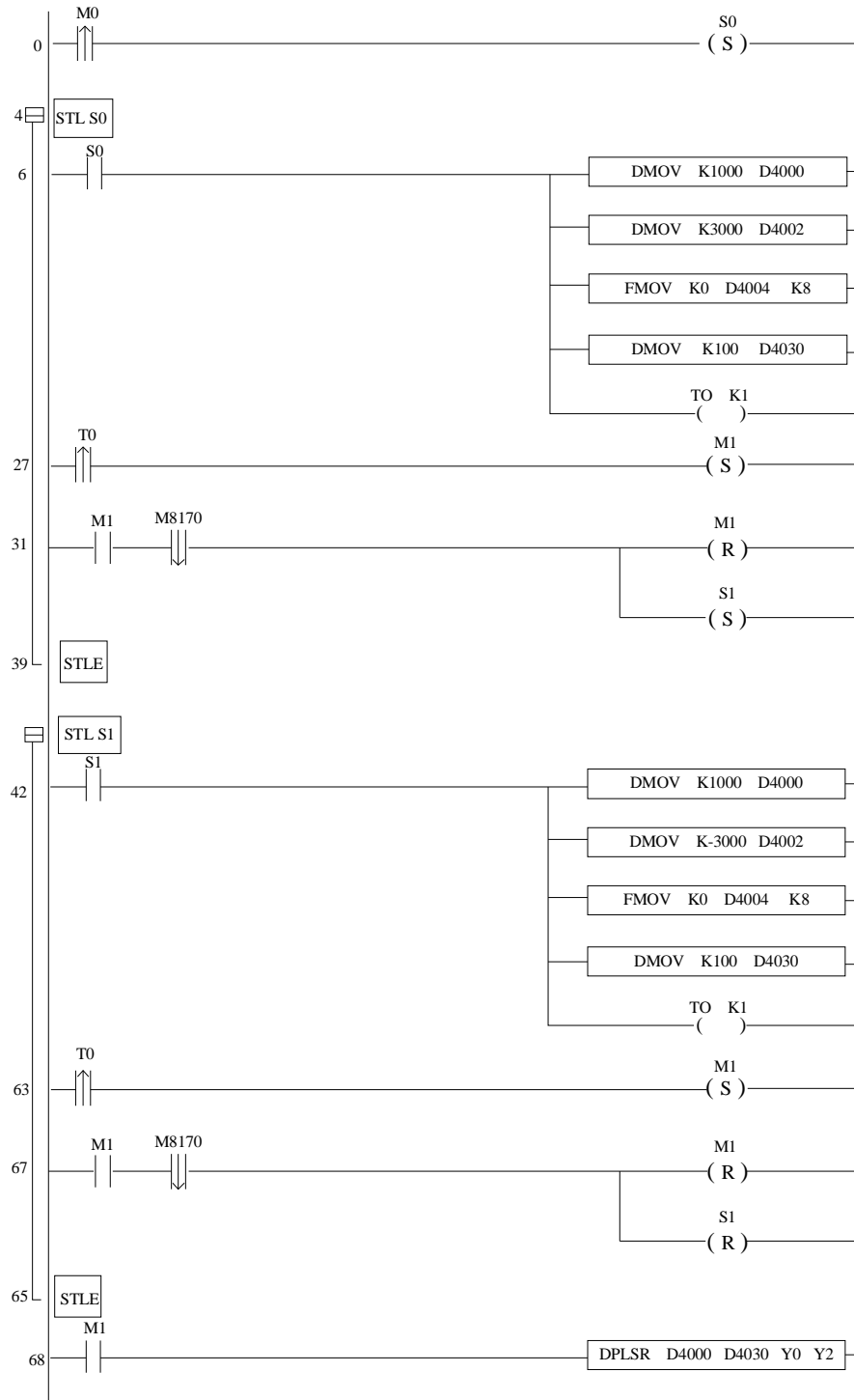

Method3: use sequence block. BLOCK can support multi-instruction sequential working. Please refer to chapter 10.

## 6-5. Sample Programs

### E.g.1: Stop at certain length

With instruction [PLSR] and [PLSNEXT], make “stop at certain length” function;

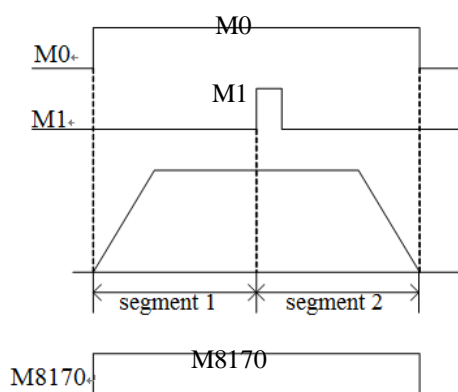

Take the sample program as the example, set two segments pulse output in D0, D1 and D2, D3, with the same frequency value; In second segment pulse output, set pulse number D3 as the output pulse number after receive M1 signal. This will realize “stop at certain length” function. See graph by the left side;

Program:

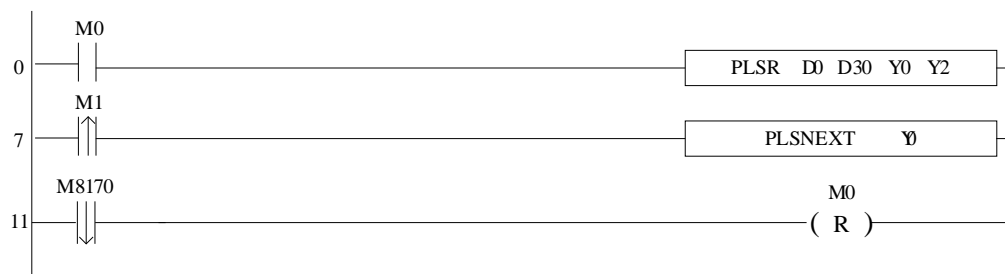

**Note:** register D0, D1, D2, D3 set the frequency and pulse quantity of segment 1 and 2. D30 set the acceleration/deceleration time, reset register D4, D5.

### E.g.2: follow function

In this sample, the pulse frequency from Y0 equals with the frequency tested from X003. If the frequency tested from X003 changes, the pulse frequency from Y0 changes;

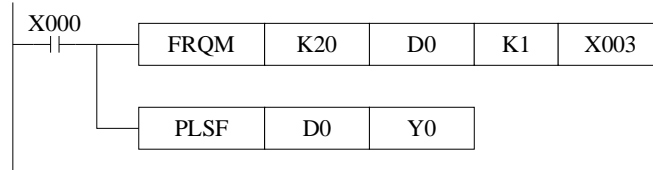

## 6-6. Relative coils and registers of pulse output

Some flags of pulse output are listed below:

| ID    | Pulse ID | Function                                     | specification  |
|-------|----------|--|--|
| M8170 | PULSE_1  | “sending pulse” flag                         | Being ON when sending the pulse,                             |
| M8171 |          | overflow flag of “32 bits pulse sending”     | When overflow, Flag is on                                    |
| M8172 |          | Direction flag                               | 1 is positive direction, the correspond direction port is on |
| M8173 | PULSE_2  | “sending pulse” flag                         | Being ON when sending the pulse,                             |
| M8174 |          | overflow flag of “32 bits pulse sending”     | When overflow, Flag is on                                    |
| M8175 |          | Direction flag                               | 1 is positive direction, the correspond direction port is on |
| M8176 | PULSE_3  | “sending pulse” flag                         | Being ON when sending the pulse,                             |
| M8177 |          | overflow flag of “32 bits pulse sending”     | When overflow, Flag is on                                    |
| M8178 |          | Direction flag                               | 1 is positive direction, the correspond direction port is on |
| M8179 | PULSE_4  | “sending pulse” flag                         | Being ON when sending the pulse,                             |
| M8180 |          | overflow flag of “32 bits pulse sending”     | When overflow, Flag is on                                    |
| M8181 |          | Direction flag                               | 1 is positive direction, the correspond direction port is on |
| M8210 | PULSE_1  | Pulse alarm flag (frequency change suddenly) | <b>1</b> is alarm, <b>0</b> is correct                       |
| M8211 |          | Neglect the alarm or not                     | When flag is 1, stop sending alarm                           |
| M8212 | PULSE_2  | Pulse alarm flag (frequency change suddenly) | <b>1</b> is alarm, <b>0</b> is correct                       |
| M8213 |          | Neglect the alarm or not                     | When flag is 1, stop sending alarm                           |
| M8214 | PULSE_3  | Pulse alarm flag (frequency change suddenly) | <b>1</b> is alarm, <b>0</b> is correct                       |
| M8215 |          | Neglect the alarm or not                     | When flag is 1, stop sending alarm                           |
| M8216 | PULSE_4  | Pulse alarm flag (frequency change suddenly) | <b>1</b> is alarm, <b>0</b> is correct                       |
| M8217 |          | Neglect the alarm or not                     | When flag is 1, stop sending alarm                           |

|       |         |  |  |
|-------|---------|--|--|
| M8218 | PULSE_5 | Pulse alarm flag (frequency change suddenly) | <b>1</b> is alarm, <b>0</b> is correct |
| M8219 |         | Neglect the alarm or not                     | When flag is 1, stop sending alarm     |

Some special registers of pulse output are listed below:

| ID    | Pulse ID | Function   | Specification                    |
|-------|----------|--|----------------------------------|
| D8170 | PULSE_1  | The low 16 bits of accumulated pulse number                      |                                  |
| D8171 |          | The high 16 bits of accumulated pulse number                     |                                  |
| D8172 |          | The current segment (means segment n)                            |                                  |
| D8173 | PULSE_2  | The low 16 bits of accumulated pulse number                      |                                  |
| D8174 |          | The high 16 bits of accumulated pulse number                     |                                  |
| D8175 |          | The current segment ( means segment n )                          |                                  |
| D8176 | PULSE_3  | The low 16 bits of accumulated pulse number                      |                                  |
| D8177 |          | The high 16 bits of accumulated pulse number                     |                                  |
| D8178 |          | The current segment ( means segment n )                          |                                  |
| D8179 | PULSE_4  | The low 16 bits of accumulated pulse number                      |                                  |
| D8180 |          | The high 16 bits of accumulated pulse number                     |                                  |
| D8181 |          | The current segment ( means segment n )                          |                                  |
| D8190 | PULSE_1  | The low 16 bits of the current accumulated current pulse number  |                                  |
| D8191 |          | The high 16 bits of the current accumulated current pulse number |                                  |
| D8192 | PULSE_2  | The low 16 bits of the current accumulated current pulse number  |                                  |
| D8193 |          | The high 16 bits of the current accumulated current pulse number |                                  |
| D8194 | PULSE_3  | The low 16 bits of the current accumulated current pulse number  | Only XC5-32RT-E (4PLS) model has |
| D8195 |          | The high 16 bits of the current accumulated current pulse number |                                  |
| D8196 | PULSE_4  | The low 16 bits of the current accumulated current pulse number  |                                  |
| D8197 |          | The high 16 bits of the current accumulated                      |                                  |

|       |         |                                    |  |
|-------|---------|------------------------------------|--|
|       |         | current pulse number               |  |
| D8210 | PULSE_1 | The error pulse segment's position |  |
| D8212 | PULSE_2 | The error pulse segment's position |  |
| D8214 | PULSE_3 | The error pulse segment's position |  |
| D8216 | PULSE_4 | The error pulse segment's position |  |
| D8218 | PULSE_5 | The error pulse segment's position |  |

Absolute position/relative position/back to origin;

| ID    | Pulse   | Function   | Description |
|-------|---------|--|-------------|
| D8230 | PULSE_1 | Rising time of the absolute/relation position instruction (Y0) |             |
| D8231 |         | Falling time of the origin return instruction (Y0)             |             |
| D8232 | PULSE_2 | Rising time of the absolute/relation position instruction (Y1) |             |
| D8233 |         | Falling time of the origin return instruction (Y1)             |             |
| D8234 | PULSE_3 | Rising time of the absolute/relation position instruction (Y2) |             |
| D8235 |         | Falling time of the origin return instruction (Y2)             |             |
| D8236 | PULSE_4 | Rising time of the absolute/relation position instruction (Y3) |             |
| D8237 |         | Falling time of the origin return instruction (Y3)             |             |
| D8238 | PULSE_5 | Rising time of the absolute/relation position instruction      |             |
| D8239 |         | Falling time of the origin return instruction                  |             |

**Note:** for frequency rising time of absolute/relative positioning instruction, the register setting value should meet the following formula:

$$\text{Register (D8230, D8232.....)} = \frac{\text{Rising time(ms)} \times \text{max frequency}}{100\text{K}}$$

For example: instruction DRVA K300080 K3000 Y0 Y4, rising time is 100ms.  
Then register D8230 (Dword) = 3=[100(ms)×3000(Hz)] ÷100K(Hz).

# 7 Communication Function

---

This chapter mainly includes: basic concept of communication, Modbus communication, free communication and CAN-bus communication;



7-1. Summary

7-2. Modbus Communication

7-3. Free Communication

7-4. CAN Communication

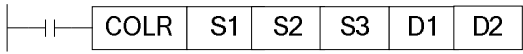
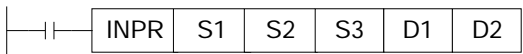
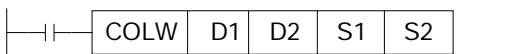
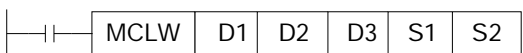
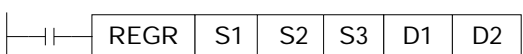
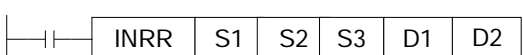
Relative Instructions:

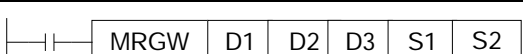
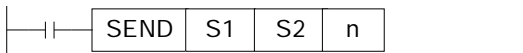
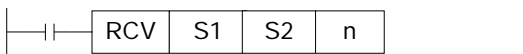
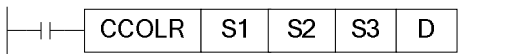
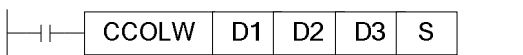
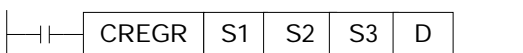
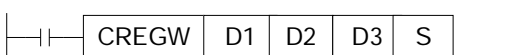
| Mnemonic                     | Function              | Circuit and Soft Components  | Chapter |
|------------------------------|-----------------------|--|---------|
| <b>MODBUS Communication</b>  |                       |  |         |
| COLR                         | Coil Read             |    | 7-2-3   |
| INPR                         | Input coil read       |    | 7-2-3   |
| COLW                         | Single coil write     |    | 7-2-3   |
| MCLW                         | Multi-coil write      |    | 7-2-3   |
| REGR                         | Register read         |    | 7-2-3   |
| INRR                         | Input register read   |    | 7-2-3   |
| REGW                         | Single register write |    | 7-2-3   |
| MRGW                         | Multi-register write  |    | 7-2-3   |
| <b>Free Communication</b>    |                       |  |         |
| SEND                         | Send data             |  | 7-3-2   |
| RCV                          | Receive data          |  | 7-3-2   |
| <b>CAN-bus Communication</b> |                       |  |         |
| CCOLR                        | Read coil             |  | 7-4-4   |
| CCOLW                        | Write coil            |  | 7-4-4   |
| CREGR                        | Read register         |  | 7-4-4   |
| CREGW                        | Write register        |  | 7-4-4   |

**7-1. Summary**

XC2-PLC, XC3-PLC, XC5-PLC main units can fulfill your requirement on communication and network. They not only support simple network (Modbus protocol、 free communication protocol), but also support those complicate network. XC2-PLC, XC3-PLC, XC5-PLC offer communication access, with which you can communicate with the devices (such as printer, instruments etc.) that have their own communication protocol.

XC2-PLC, XC3-PLC, XC5-PLC all support Modbus protocol、 free protocol these communication function, XC5-PLC also have CANbus function.

**7-1-1. COM port**

**COM Port**

There are 2 COM ports (Port1、Port2) on XC3 series PLC basic units, while there are 3 COM ports on XC5 series PLC main units. Besides the same COM ports (COM1、 COM2), they have also CAN COM port.

COM 1 (Port1) is the programming port; it can be used to download the program and connect with the other devices. The parameters (baud rate, data bit etc.) of this COM port are fixed, can't be re-set.

**Note:**

**PLC hardware version less than v3.1: port 1 parameters cannot be changed, otherwise port 1 cannot connect to PC**

**PLC hardware version higher than v3.2: port 1 parameters cannot be changed. But user can stop the PLC when start, and then initialize the PLC.**

COM 2 (Port2) is communication port; it can be used to download program and connect with other devices. The parameters (baud rate, data bit etc.) of this COM port can be changed via software.

Via BD cards, XC series PLC can expand port 3. These COM ports can be RS232 and RS485.

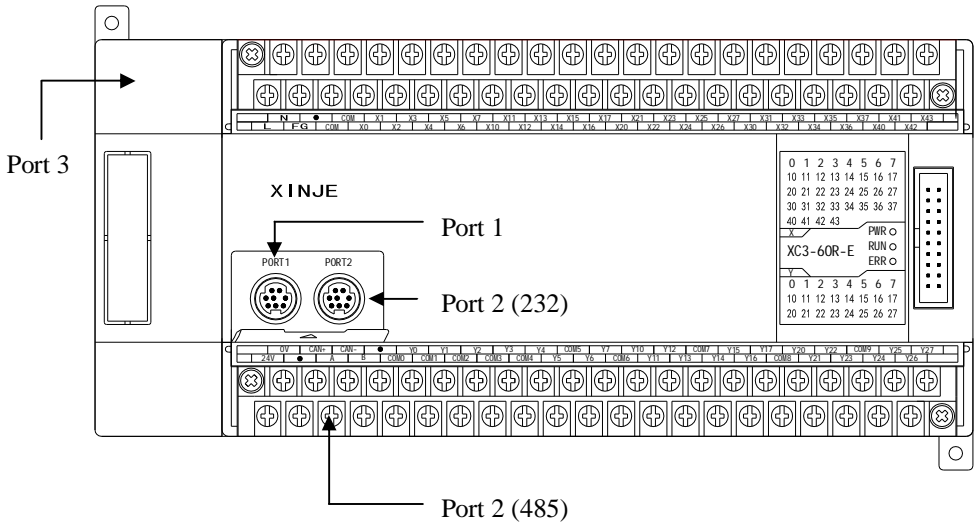

**1. RS232 Port**

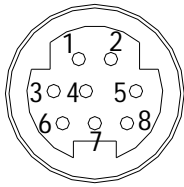

- 2: PRG
- 4: RxD
- 5: TxD
- 6: VCC
- 8: GND

Mini Din 8 pin female

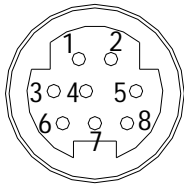

- 4: RxD
- 5: TxD
- 8: GND

Mini Din 8 pin female

Note:

- 1. Port 1 support RS232.
- 2. Port 2 support RS232, RS485. But RS232 and RS485 cannot be used at the same time.
- 3. Port 3 support RS232, RS485. But RS232 and RS485 cannot be used at the same time. (Need to expand XC-COM-BD).

**2. RS485 port:**

About RS485 port, A is “+” signal、 B is “-“ signal.  
The A, B terminals (RS485) on XC series PLC is the same port to Port 2. These two ports cannot be used at the same time. (The same to Port 3). Please use twisted pair cable for RS485. (See below diagram). But shielded twisted pair cable is better and the single-ended connect to the ground.

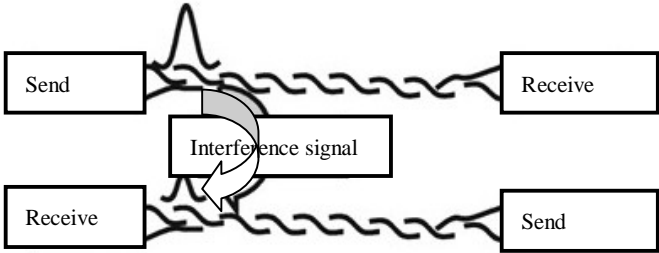

**3. CAN port:**

CAN port can be applied to CANBUS communication. The pin terminals are “CAN+”, “CAN-“  
For the detailed CAN communication functions, please refer to chapter 7-4 CAN bus function.

## 7-1-2. Communication Parameters

### Communication Parameters

|           |  |
|-----------|--|
| Station   | Modbus Station number: 1~254、255 (FF) is free format communication |
| Baud Rate | 300bps~115.2Kbps   |
| Data Bit  | 8 bits data、7 bits data  |
| Stop Bit  | 2 stop bits、1 stop bit   |
| Parity    | Even、Odd、No check  |

The default parameters of COM 1:

Station number is 1、baud rate is 19200bps、8 data bit、1 stop bit、Even parity

### Parameters Setting

Set the parameters with the COM ports on XC series PLC;

|       | Number | Function                    | Description  |
|-------|--------|-----------------------------|--|
| COM 1 | FD8210 | Communication mode          | 255 is free format,<br><b>1~254 bit is Modbus station number</b>       |
|       | FD8211 | Communication format        | Baud rate, data bit, stop bit, parity                                  |
|       | FD8212 | ASC timeout judgment time   | Unit: ms, if set to be 0, it means no timeout waiting                  |
|       | FD8213 | Reply timeout judgment time | Unit: ms, if set to be 0, it means no timeout waiting                  |
|       | FD8214 | Start symbol                | High 8 bits invalid  |
|       | FD8215 | End symbol                  | High 8 bits invalid  |
|       | FD8216 | Free format setting         | 8/16 bits cushion,<br>with/without start bit,<br>with/without stop bit |
| COM 2 | FD8220 | Communication mode          | 255 is free format,<br><b>1~254 bit is Modbus station number</b>       |
|       | FD8221 | Communication format        | Baud rate, data bit, stop bit, parity                                  |
|       | FD8222 | ASC timeout judgment time   | Unit: ms, if set to be 0, it means no timeout waiting                  |
|       | FD8223 | Reply timeout judgment time | Unit: ms, if set to be 0, it means no timeout waiting                  |
|       | FD8224 | Start symbol                | High 8 bits invalid  |
|       | FD8225 | End symbol                  | High 8 bits invalid  |

|       |        |                             |  |
|-------|--------|-----------------------------|--|
|       | FD8226 | Free format setting         | 8/16 bits cushion,<br>with/without start bit,<br>with/without stop bit |
| COM 3 | FD8230 | Communication mode          | 255 is free format,<br><b>1~254 bit is Modbus station number</b>       |
|       | FD8231 | Communication format        | Baud rate, data bit, stop bit, parity                                  |
|       | FD8232 | ASC timeout judgment time   | Unit: ms, if set to be 0, it means no<br>timeout waiting               |
|       | FD8233 | Reply timeout judgment time | Unit: ms, if set to be 0, it means no<br>timeout waiting               |
|       | FD8234 | Start symbol                | High 8 bits invalid  |
|       | FD8235 | End symbol                  | High 8 bits invalid  |
|       | FD8236 | Free format setting         | 8/16 bits cushion,<br>with/without start bit,<br>with/without stop bit |

※1: The PLC will be off line after changing the communication parameters, use “stop when  
reboot” function to keep PLC online;

※2: After modifying the data with special FLASH data registers, the new data will get into effect  
after reboot;

Set the communication parameters:

FD8211 (COM1)/FD8221 (COM2)/FD8231 (COM3)

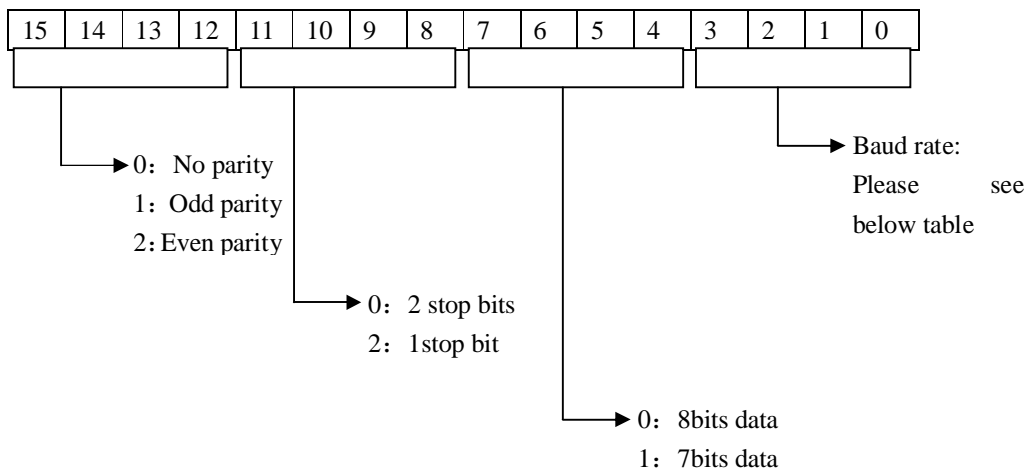

**bit0~bit3 baud rate:**

| Baud rate     | Suitable type | Baud rate    | Suitable type |             |
|---------------|---------------|--------------|---------------|-------------|
| 0: 300bps     | XC1           | 0: 768Kbps   | -             | XC2、XCM、XCC |
| 1: 600bps     | XC1           | 1: 600bps    | XC3、XC5       | XC2、XCM、XCC |
| 2: 1200 bps   | XC1           | 2: 1200 bps  | XC3、XC5       | XC2、XCM、XCC |
| 3: 2400 bps   | XC1           | 3: 2400 bps  | XC3、XC5       | XC2、XCM、XCC |
| 4: 4800 bps   | XC1           | 4: 4800 bps  | XC3、XC5       | XC2、XCM、XCC |
| 5: 9600 bps   | XC1           | 5: 9600 bps  | XC3、XC5       | XC2、XCM、XCC |
| 6: 19.2K bps  | XC1           | 6: 19.2Kbps  | XC3、XC5       | XC2、XCM、XCC |
| 7: 38.4K bps  | XC1           | 7: 38.4Kbps  | XC3、XC5       | XC2、XCM、XCC |
| 8: 57.6K bps  | XC1           | 8: 57.6Kbps  | XC3、XC5       | -           |
| 9: 115.2K bps | XC1           | 9: 115.2Kbps | XC3、XC5       | -           |
| -             | -             | A: 192Kbps   | XC3、XC5       | XC2、XCM、XCC |
| -             | -             | B: 256Kbps   | -             | XC2、XCM、XCC |
| -             | -             | C: 288Kbps   | XC3、XC5       | -           |
| -             | -             | D: 384Kbps   | XC3、XC5       | XC2、XCM、XCC |
| -             | -             | E: 512Kbps   | -             | XC2、XCM、XCC |
| -             | -             | F: 576Kbps   | XC3、XC5       | -           |

FD8216 (COM1)/FD8226 (COM2)/FD8236 (COM3)

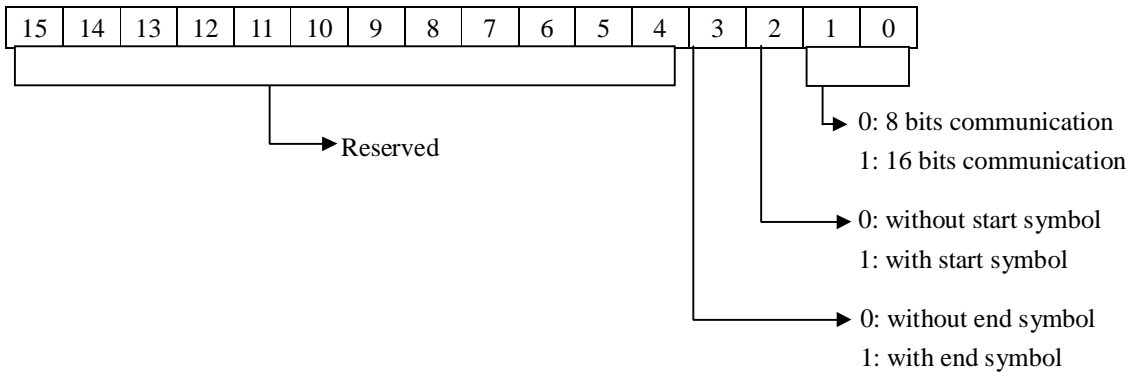

**Note:** user doesn't have to calculate the FD value to set the communication parameter.  
Please set the parameters in XCPpro software.

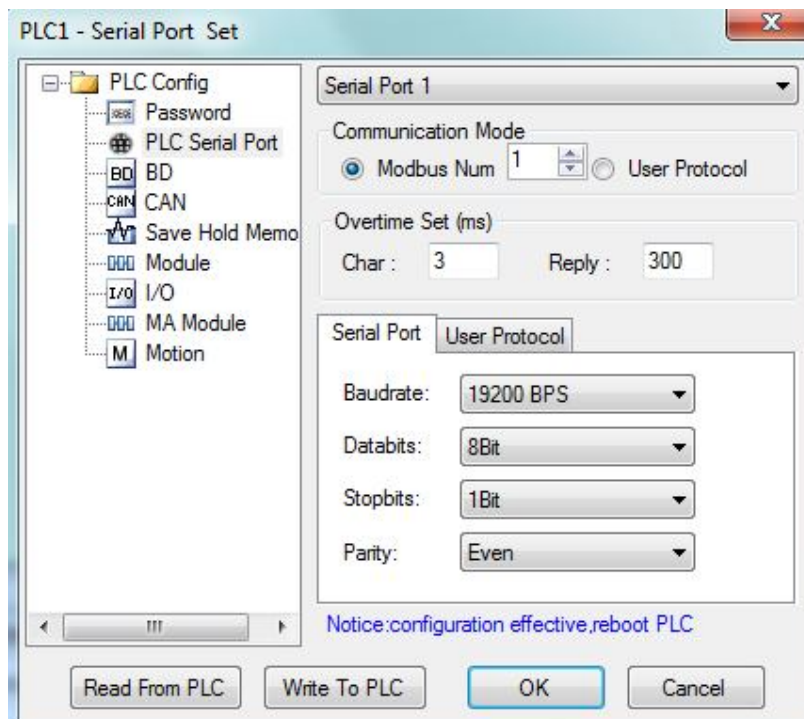
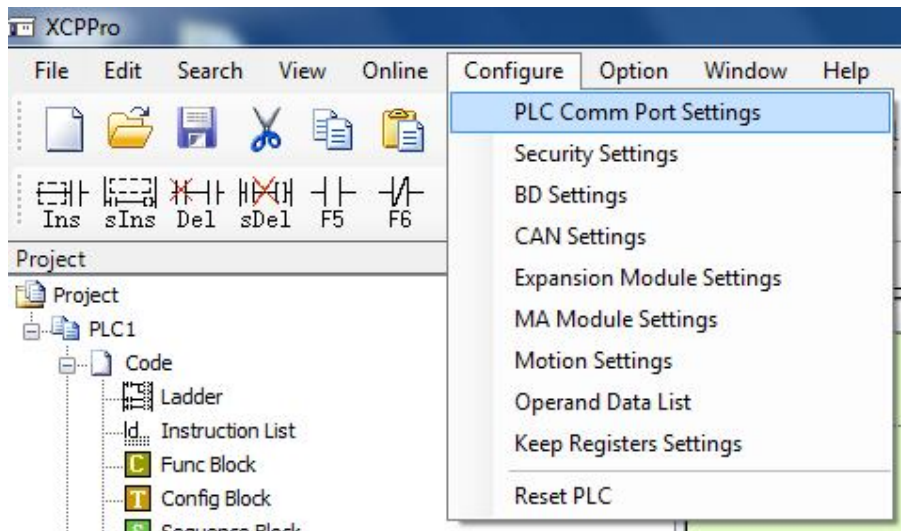

After changing the parameters, please restart the PLC to make it effective.

## 7-2. MODBUS Communication

### 7-2-1. Function

XC series PLC support both Modbus master and Modbus slave.

Master mode: When PLC is set to be master, PLC sends request to other slave devices via Modbus instructions, other devices response the master. For example, Xinje PLC can control the inverter through Modbus.

Slave mode: when PLC is set to be slave, it can only response with other master devices.

Master and slave: in RS485 network, there are one maser and several slaves at one time (see below diagram). The master station can read and write any slave stations. Two slave stations cannot communicate with each other. Master station communicates with slave station through Modbus instructions. Slave station has no program but only response the master station. (wiring: connect all the RS485 +, connect all the RS485-)

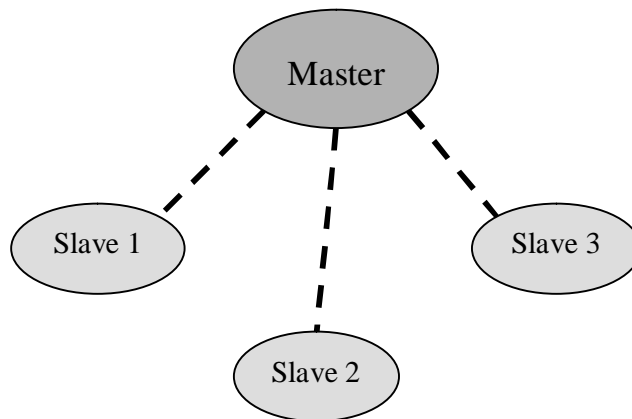

In RS232 network, there is only one master and one slave.

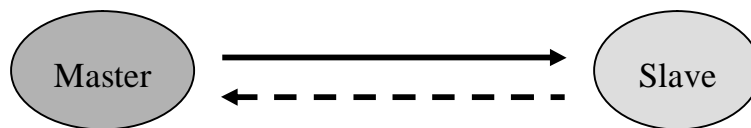

There is dotted line in the diagram. It means any PLC can be master station when the entire PLC in the network don't send data. But more than one PLC will send data at one time, the communication will fail. It is not recommended to use.

Note: For XC series PLC, RS232 only support half-duplex.

## 7-2-2. Address

For the soft component's number in PLC which corresponds with Modbus address number, please see the following table:

Coil address: (Modbus ID prefix is "0x")

| Bit ID      | ModbusID<br>( decimal K) | Modbus ID<br>(Hex. H) |
|-------------|--------------------------|-----------------------|
| M0~M7999    | 0~7999                   | 0~1F3F                |
| X0~X1037    | 16384~16927              | 4000~421F             |
| Y0~Y1037    | 18432~18975              | 4800~4A1F             |
| S0~S1023    | 20480~21503              | 5000~53FF             |
| M8000~M8511 | 24576~25087              | 6000~61FF             |
| T0~T618     | 25600~26218              | 6400~666A             |
| C0~C634     | 27648~28282              | 6C00~6E7A             |

Register address: (Modbus ID prefix is "4x")

| Word ID       | ModbusID<br>( decimal K) | Modbus ID<br>(Hex. H) |
|---------------|--------------------------|-----------------------|
| D0~D7999      | 0~7999                   | 0~1F3F                |
| TD0~TD618     | 12288~12906              | 3000~326A             |
| CD0~CD634     | 14336~14970              | 3800~3A7A             |
| D8000~D8511   | 16384~16895              | 4000~41FF             |
| FD0~FD5000    | 18432~23432              | 4800~5B88             |
| FD8000~FD8511 | 26624~27135              | 6800~69FF             |

- The address is used when PLC uses Modbus-RTU protocol. The host machine is PLC, HMI or SCADA.
- If the host machine is PLC, please write the program as Modbus-RTU protocol. If the host machine is HMI or SCADA, there are two conditions. Condition one: with Xinje driver such as Xinje HMI. Please write the program with PLC soft components (Y0, M0, D0...). Condition two: without Xinje driver. Please choose Modbus-RTU protocol, the address is as the above table.

---

※1: Bit soft components X, Y are in Octal form, others are in decimal form.

For example: X10 modbus address is not K16394 but K16392.

Y100 modbus address is K18496.

Note: octal has no Y8/Y9 and Y80/Y90.

---

## 7-2-3 Modbus communication format

Modbus communication data format

1. RTU mode:

|              |  |
|--------------|--|
| START        | No signal input $\geq 10\text{ms}$                       |
| Address      | Communication address: 8-bit binary                      |
| Function     | Function code: 8-bit binary                              |
| DATA (n - 1) | Data contents:<br>N*8-bit data, N $\leq 8$ , max 8 bytes |
| .....        |  |
| DATA 0       |  |
| CRC CHK Low  | CRC check code   |
| CRC CHK High | 16-bit CRC check code is built up by 2 8-bit binary      |
| END          | No signal input $\geq 10\text{ms}$                       |

2. Modbus address

00H: all the Xinje XC series PLC broadcast ---- slave stations don't response.

01H: communicate with address 01H PLC

0FH: communicate with address 0FH PLC

10H: communicate with address 10H PLC.....the max address is FEH (254)

3. Function and DATA

| Function code | Function             | Modbus instruction |
|---------------|----------------------|--------------------|
| 01H           | Read coil            | COLR               |
| 02H           | Read input coil      | INRR               |
| 03H           | Read register        | REGR               |
| 04H           | Read input register  | INRR               |
| 05H           | Write coil           | COLW               |
| 06H           | Write register       | REGW               |
| 10H           | Write multi-register | MRGW               |
| 0FH           | Write multi-coil     | MCLW               |

Now we use function code 06H to introduce the data format.

For example: write data to register D2 (address H0002)

RTU mode:

| Asking format    |     | Response format  |     |
|------------------|-----|------------------|-----|
| Address          | 01H | Address          | 01H |
| Function code    | 06H | Function code    | 06H |
| Register address | 00H | Register address | 00H |
|                  | 02H |                  | 02H |
| Data contents    | 13H | Data contents    | 13H |
|                  | 88H |                  | 88H |

|                |     |                |     |
|----------------|-----|----------------|-----|
| CRC CHECK Low  | 25H | CRC CHECK Low  | 25H |
| CRC CHECK High | 5CH | CRC CHECK High | 5CH |

Explanation:

1. Address is PLC station no.
2. Function code is Modbus-RTU protocol read/write code.
3. Register address is the PLC modbus address, please see chapter 7-2-2.
4. Data contents is the value in D2.
5. CRC CHECK Low / CRC CHECK High is low bit and high bit of CRC check value

If 2 pieces of XINJE XC series PLC communicate with each other, write K5000 to D2.



M0 is trigger condition. If the communication is failure, the instruction will try twice again. If the third time communication is failure, the communication ends.

The relationship between REGW and Modbus RTU protocol (other instructions are the same)

|       |                     |
|-------|---------------------|
| REGW  | Function code 06H   |
| K1    | Station no.         |
| H0002 | Modbus address      |
| K5000 | Data contents 1388H |
| K2    | PLC serial port     |

The complete communication data are : 01H 06H 00H 02H 13H 88H (system take the CRC checking automatically)

If monitor the serial port data by serial port debugging tool, the data are: 01 06 00 02 13 88 25 5C

**Note:** the instruction doesn't distinguish decimal, hex, binary, hex, octal, etc. For example, B10000, K16 and H10 are the same value, so the following instructions are the same.

```
REGW  K1  B111110100  D1  K2
REGW  K1  K500          D1  K2
REGW  K1  H1F4          D1  K2
```

## 7-2-4. Communication Instructions

Modbus instructions include coil read/write, register read/write; below, we describe these instructions in details:

The operand definition in the instruction:

### 1. Remote communication station and serial port number

For example, one PLC connects 3 inverters. PLC needs to write and read the parameters of inverter. The inverter station no. is 1, 2, and 3. So the remote communication station no. is 1, 2, and 3.

### 2. Remote register/coil quantity

For example, PLC read inverter frequency (H2103), output current (H2104) and bus voltage (H2105). So the remote register first address is H2103, quantity is K3 (3 registers).

### 3. Local coil/register address

For example, local coil is M0, write the M0 state to remote coil.

Local register is D0, write the D0 value to remote register.

## > Coil Read [COLR]

### 1、Instruction Summary

Read the specified station's specified coil status to the local PLC;

| Coil read [COLR]     |                      |                      |                         |
|----------------------|----------------------|----------------------|-------------------------|
| 16 bits instruction  | COLR                 | 32 bits instruction  | -                       |
| Execution Condition  | Normally ON/OFF coil | Suitable Models      | XC2, XC3, XC5, XCM, XCC |
| Hardware Requirement | -                    | Software Requirement | -                       |

### 2、Operands

| Operands | Function                                 | Type        |
|----------|--|-------------|
| S1       | Specify the remote communication station | 16bits, BIN |
| S2       | Specify the remote coil first address    | 16bits, BIN |
| S3       | Specify the coil quantity                | 16bits, BIN |
| D1       | Specify the local coil first address     | bit         |
| D2       | Specify the serial port no.              | 16bits, BIN |

### 3、suitable soft components

|      |          |          |    |    |    |    |    |     |    |          |        |    |    |
|------|----------|----------|----|----|----|----|----|-----|----|----------|--------|----|----|
| Word | Operands | System   |    |    |    |    |    |     |    | constant | module |    |    |
|      |          | D        | FD | ED | TD | CD | DX | DY  | DM | DS       | K/H    | ID | QD |
|      | S1       | •        | •  |    | •  | •  |    |     |    |          | •      |    |    |
|      | S2       | •        | •  |    | •  | •  |    |     |    |          | •      |    |    |
|      | S3       | •        | •  |    | •  | •  |    |     |    |          | •      |    |    |
| D2   |          |          |    |    |    |    |    |     |    | K        |        |    |    |
| Bit  | Operands | Operands |    |    |    |    |    |     |    |          |        |    |    |
|      |          | X        | Y  | M  | S  | T  | C  | Dnm |    |          |        |    |    |
|      | D1       | •        | •  | •  | •  | •  | •  |     |    |          |        |    |    |

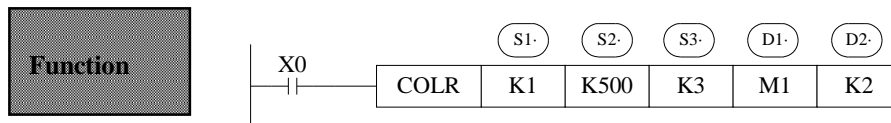

- Read coil instruction, Modbus function code is 01H
- Serial Port: K1~K3
- Operand S3: K1~K984, the max coil quantity is 984

### ➤ Input Coil Read [INPR]

#### 1、Instruction

Read the specified station's specified input coils into local coils:

| Input coil read [INPR] |                              |                      |                         |
|------------------------|------------------------------|----------------------|-------------------------|
| 16 bits instruction    | INPR                         | 32 bits instruction  | -                       |
| Execution Condition    | Normally ON/OFF、 rising edge | Suitable Models      | XC2, XC3, XC5, XCM, XCC |
| Hardware Requirement   | -                            | Software Requirement | -                       |

#### 2、Operands

| Operands | Function                                 | Type        |
|----------|--|-------------|
| S1       | Specify the remote communication station | 16bits, BIN |
| S2       | Specify the remote coil first address    | 16bits, BIN |
| S3       | Specify the coil quantity                | 16bits, BIN |
| D1       | Specify the local coil first address     | bit         |
| D2       | Specify the serial port no.              | 16bits, BIN |

### 3、Suitable Soft Components

| Word | Operands | System |    |    |    |    |    |    |    | constant | module |    |    |
|------|----------|--------|----|----|----|----|----|----|----|----------|--------|----|----|
|      |          | D      | FD | ED | TD | CD | DX | DY | DM | DS       | K/H    | ID | QD |
| S1   | •        | •      |    |    | •  | •  |    |    |    |          | •      |    |    |
| S2   | •        | •      |    |    | •  | •  |    |    |    |          | •      |    |    |
| S3   | •        | •      |    |    | •  | •  |    |    |    |          | •      |    |    |
| D2   |          |        |    |    |    |    |    |    |    |          | K      |    |    |

| Bit | Operands | System |   |   |   |   |   |     |
|-----|----------|--------|---|---|---|---|---|-----|
|     |          | X      | Y | M | S | T | C | Dnm |
| D1  | •        | •      | • | • | • | • |   |     |

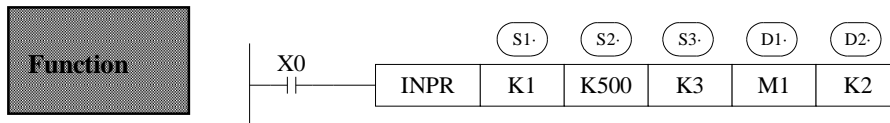

- Instruction to read the input coil, Modbus function code is 02H
- Serial port: K1~K3
- Operand S3: K1~K984, the max coil quantity is 984
- When X0 is ON, execute COLR or INPR instruction, set communication flag after execution the instruction; when X0 is OFF, no operation. If error happens during communication, resend automatically. If the errors reach 3 times, set the communication error flag. The user can check the relative registers to judge the error

#### ➤ single coil write [COLW]

##### 1、summary

Write the local coil status to the specified station's specified coil;

| Single coil write [COLW] |                              |                      |                         |
|--------------------------|------------------------------|----------------------|-------------------------|
| 16 bits instruction      | COLW                         | 32 bits instruction  | -                       |
| Execution Condition      | Normally ON/OFF、 rising edge | Suitable Models      | XC2, XC3, XC5, XCM, XCC |
| Hardware Requirement     | -                            | Software Requirement | -                       |

## 2、 Operands

| Operands | Function                                 | Type        |
|----------|--|-------------|
| D1       | Specify the remote communication station | 16bits, BIN |
| D2       | Specify the remote coil first address    | 16bits, BIN |
| S1       | Specify the local coil first address     | bit         |
| S2       | Specify the serial port no.              | 16bits, BIN |

## 3、 suitable soft components

| Word | Operands | System |    |    |    |    |    |    |    | constant | module |    |    |
|------|----------|--------|----|----|----|----|----|----|----|----------|--------|----|----|
|      |          | D      | FD | ED | TD | CD | DX | DY | DM | DS       | K/H    | ID | QD |
|      | D1       | •      | •  |    | •  | •  |    |    |    |          | •      |    |    |
|      | D2       | •      | •  |    | •  | •  |    |    |    |          | •      |    |    |
|      | S2       |        |    |    |    |    |    |    |    |          | K      |    |    |

| Bit | Operands | System |   |   |   |   |   |     |
|-----|----------|--------|---|---|---|---|---|-----|
|     |          | X      | Y | M | S | T | C | Dnm |
|     | S1       | •      | • | • | • | • | • |     |

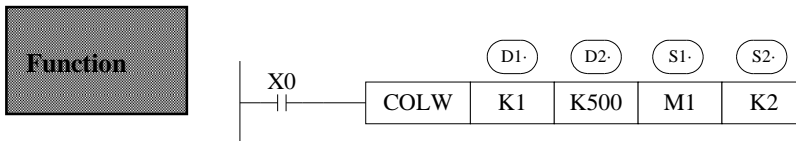

- Write the single coil, Modbus function code is 05H
- Serial port: K1~K3

## ➤ multi-coil write [MCLW]

### 1、 Summary

Write the local multi-coil status into the specified station's specified coil;

| Multi-coil write [MCLW] |                              |                      |                         |
|-------------------------|------------------------------|----------------------|-------------------------|
| 16 bits instruction     | MCLW                         | 32 bits instruction  | -                       |
| Execution Condition     | Normally ON/OFF、 rising edge | Suitable Models      | XC2, XC3, XC5, XCM, XCC |
| Hardware Requirement    | -                            | Software Requirement | -                       |

## 2、Operands

| Operands | Function                                 | Type        |
|----------|--|-------------|
| D1       | Specify the remote communication station | 16bits, BIN |
| D2       | Specify the remote coil first address    | 16bits, BIN |
| D3       | Specify the coil quantity                | 16bits, BIN |
| S1       | Specify the local coil first address     | bit         |
| S2       | Specify the serial port no.              | 16bits, BIN |

## 3、Suitable soft components

| Word | Operands | System |    |    |    |    |    |    |    | constant | module |    |    |
|------|----------|--------|----|----|----|----|----|----|----|----------|--------|----|----|
|      |          | D      | FD | ED | TD | CD | DX | DY | DM | DS       | K/H    | ID | QD |
|      | D1       | •      | •  |    | •  | •  |    |    |    |          | •      |    |    |
|      | D2       | •      | •  |    | •  | •  |    |    |    |          | •      |    |    |
|      | D3       | •      | •  |    | •  | •  |    |    |    |          | •      |    |    |
|      | S2       |        |    |    |    |    |    |    |    |          | K      |    |    |

| Bit | Operands | System |   |   |   |   |   |     |
|-----|----------|--------|---|---|---|---|---|-----|
|     |          | X      | Y | M | S | T | C | Dnm |
|     | S1       | •      | • | • | • | • | • |     |

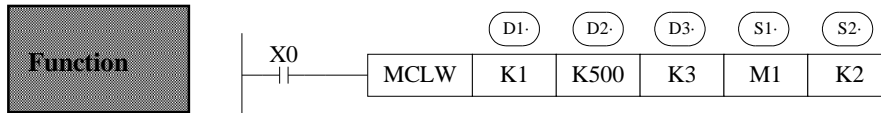

- Instruction to write the multiply coils, Modbus function code is 0FH
- Serial port: K1~K3
- Operand D3: the max coil quantity is 952
- When X0 is ON, execute COLW or MCLW instruction, set communication flag after execution the instruction; when X0 is OFF, no operation. If error happens during communication, resend automatically. If the errors reach 3 times, set the communication error flag. The user can check the relative registers to judge the error;

## ➤ Register Read [REGR]

### 1、Summary

Read the specified station's specified register to the local register;

| Register read [REGR] |      |                       |
|----------------------|------|-----------------------|
| 16 bits instruction  | REGR | 32 bits instruction - |

|                      |                             |                      |                         |
|----------------------|-----------------------------|----------------------|-------------------------|
| Execution Condition  | Normally ON/OFF、rising edge | Suitable Models      | XC2, XC3, XC5, XCM, XCC |
| Hardware Requirement | -                           | Software Requirement | -                       |

## 2、Operands

| Operands | Function                                  | Type        |
|----------|---|-------------|
| S1       | Specify the remote communication station  | 16bits, BIN |
| S2       | Specify the remote register first address | 16bits, BIN |
| S3       | Specify the register quantity             | 16bits, BIN |
| D1       | Specify the local register first address  | bit         |
| D2       | Specify the serial port no.               | 16bits, BIN |

## 3、Suitable soft components

| Word | Operands | System |    |    |    |    |    |    |    | constant | module |    |    |
|------|----------|--------|----|----|----|----|----|----|----|----------|--------|----|----|
|      |          | D      | FD | ED | TD | CD | DX | DY | DM | DS       | K/H    | ID | QD |
|      | S1       | •      | •  |    | •  | •  |    |    |    |          | •      |    |    |
|      | S2       | •      | •  |    | •  | •  |    |    |    |          | •      |    |    |
|      | S3       | •      | •  |    | •  | •  |    |    |    |          | •      |    |    |
|      | D1       | •      |    |    |    |    |    |    |    |          |        |    |    |
|      | D2       |        |    |    |    |    |    |    |    |          | K      |    |    |

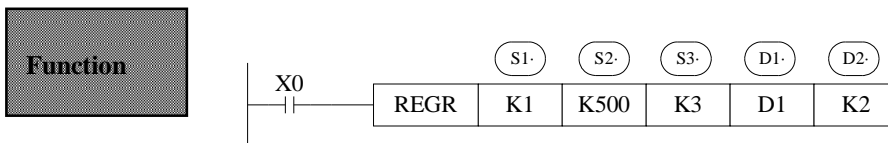

- Instruction to read the REGISTERS, Modbus function code is 03H
- Serial port: K1~K3
- Operand S3: the max register quantity is 61

**Read Input Register [INRR]**

1、 Summary

Read the specified station's specified input register to the local register

| Read Input Register [INRR] |                              |                      |                         |
|----------------------------|------------------------------|----------------------|-------------------------|
| 16 bits instruction        | INRR                         | 32 bits instruction  | -                       |
| Execution Condition        | Normally ON/OFF、 rising edge | Suitable Models      | XC2, XC3, XC5, XCM, XCC |
| Hardware Requirement       | -                            | Software Requirement | -                       |

2、 Operands

| Operands | Function                                  | Type        |
|----------|---|-------------|
| S1       | Specify the remote communication station  | 16bits, BIN |
| S2       | Specify the remote register first address | 16bits, BIN |
| S3       | Specify the register quantity             | 16bits, BIN |
| D1       | Specify the local register first address  | 16bits, BIN |
| D2       | Specify the serial port no.               | 16bits, BIN |

3、 Suitable soft components

| Word | Operands | System |    |    |    |    |    |    |    | constant | module |    |    |
|------|----------|--------|----|----|----|----|----|----|----|----------|--------|----|----|
|      |          | D      | HD | ED | TD | CD | DX | DY | DM | DS       | K/H    | ID | QD |
| S1   |          | •      | •  |    | •  | •  |    |    |    |          | •      |    |    |
| S2   |          | •      | •  |    | •  | •  |    |    |    |          | •      |    |    |
| S3   |          | •      | •  |    | •  | •  |    |    |    |          | •      |    |    |
| D1   |          | •      |    |    |    |    |    |    |    |          |        |    |    |
| D2   |          |        |    |    |    |    |    |    |    |          | K      |    |    |

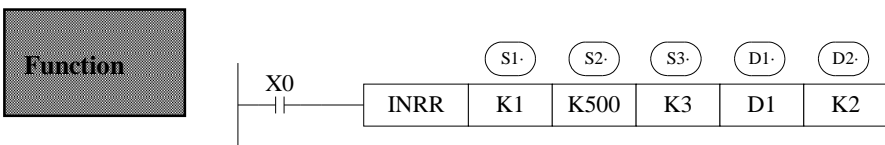

- Instruction to read the input registers, Modbus function code is 04H
- Serial port: K1~K3
- Operand S3: the max input register quantity is 61
- When X0 is ON, execute REGR or INRR instruction, set communication flag after execution the instruction; when X0 is OFF, no operation. If error happens during communication, resend automatically. If the errors reach 4 times, set the communication error flag. The user can check the relative registers to judge the error;

**Single register write [REGW]**

1、summary

Instruction to write the local specified register into the specified station's specified register;

| Single register write [REGW] |                              |                      |                         |
|------------------------------|------------------------------|----------------------|-------------------------|
| 16 bits instruction          | REGW                         | 32 bits instruction  | -                       |
| Execution Condition          | Normally ON/OFF、 rising edge | Suitable Models      | XC2, XC3, XC5, XCM, XCC |
| Hardware Requirement         | -                            | Software Requirement | -                       |

2、 Operands

| Operands | Function                                  | Type        |
|----------|---|-------------|
| D1       | Specify the remote communication station  | 16bits, BIN |
| D2       | Specify the remote register first address | 16bits, BIN |
| S1       | Specify the local register first address  | 16bits, BIN |
| S2       | Specify the serial port no.               | 16bits, BIN |

3、 Suitable soft components

| Word | Operands | System |    |    |    |    |    |    |    | constant | module |    |    |
|------|----------|--------|----|----|----|----|----|----|----|----------|--------|----|----|
|      |          | D      | FD | ED | TD | CD | DX | DY | DM | DS       | K/H    | ID | QD |
|      | D1       | •      | •  |    | •  | •  |    |    |    |          | •      |    |    |
|      | D2       | •      | •  |    | •  | •  |    |    |    |          | •      |    |    |
|      | S1       | •      |    |    |    |    |    |    |    |          |        |    |    |
|      | S2       |        |    |    |    |    |    |    |    |          | K      |    |    |

**Function**

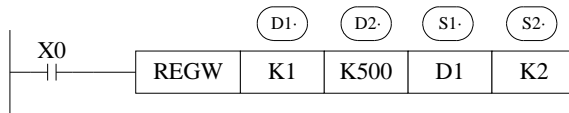

- Write the single register, Modbus function code is 06H
- Serial port: K1~K3

**Multi-register write [MRGW]**

1、 Summary

Instruction to write the local specified register to the specified station's specified register;

| Multi-register write [MRGW] |                               |                      |                         |
|-----------------------------|-------------------------------|----------------------|-------------------------|
| 16 bits instruction         | MRGW                          | 32 bits instruction  | -                       |
| Execution Condition         | Normally ON/OFF 、 rising edge | Suitable Models      | XC2, XC3, XC5, XCM, XCC |
| Hardware Requirement        | -                             | Software Requirement | -                       |

2、 Operands

| Operands | Function                                  | Type        |
|----------|---|-------------|
| D1       | Specify the remote communication station  | 16bits, BIN |
| D2       | Specify the remote register first address | 16bits, BIN |
| D3       | Specify the register quantity             | 16bits, BIN |
| S1       | Specify the local register first address  | 16bits, BIN |
| S2       | Specify the serial port no.               | 16bits, BIN |

3、 Suitable soft components

| Word | Operands | System |    |    |    |    |    |    |    | constant | module |    |    |
|------|----------|--------|----|----|----|----|----|----|----|----------|--------|----|----|
|      |          | D      | FD | ED | TD | CD | DX | DY | DM | DS       | K/H    | ID | QD |
| D1   |          | •      | •  |    | •  | •  |    |    |    |          | •      |    |    |
| D2   |          | •      | •  |    | •  | •  |    |    |    |          | •      |    |    |
| S1   |          | •      |    |    |    |    |    |    |    |          |        |    |    |
| S2   |          |        |    |    |    |    |    |    |    |          | K      |    |    |

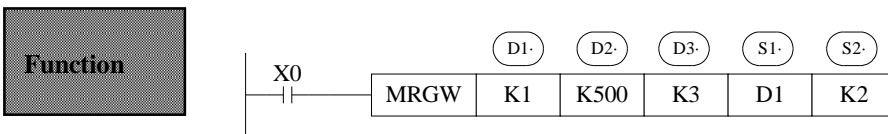

- Instruction to write the multiply registers, Modbus function code is 10H
- Serial port: K1~K3
- Operand D3: the max register quantity is 59
- When X0 is ON, execute REGW or MRGW instruction, set communication flag after execution the instruction; when X0 is OFF, no operation. If error happens during communication, resend automatically. If the errors reach 4 times, set the communication error flag. The user can check the relative registers to judge the error;

## 7-2-5. Application

- Wiring method

There are two wiring methods:

A、RS232 wiring method

COM2\*1 diagram

4: RxD  
5: TxD  
8: GND

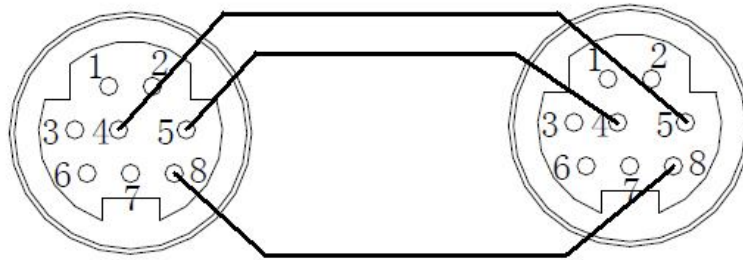

Mini Din 8 Pins port

Note:

- (1) COM2 with \*1 only show the RS232 pins. The RS485 pins are external terminal, which is not listed.
- (2) XC series PLC RS232 cannot support full-duplex; it only can communicate in single direction.
- (3) The communication distance of RS232 is not far (about 13m). RS485 can be further.

B、485 wiring method

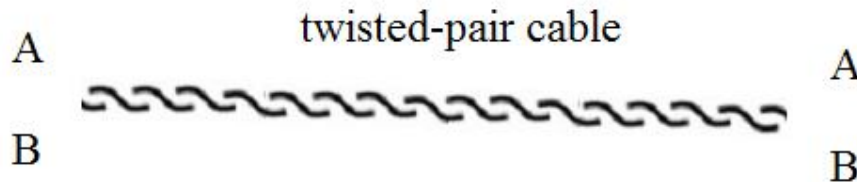

Connect all terminal A, connect all the terminal B. A is RS485+, B is RS485-.

Application:

One XC series PLC connects 3 XC series PLCs. 3 slave PLCs follow the master's action. Master PLC Y0 ON, slave Y0 ON. Master PLC Y0 OFF, slave PLC Y0 OFF. But the action of 3 slave PLCs cannot be very synchronous.

## Method 1 program

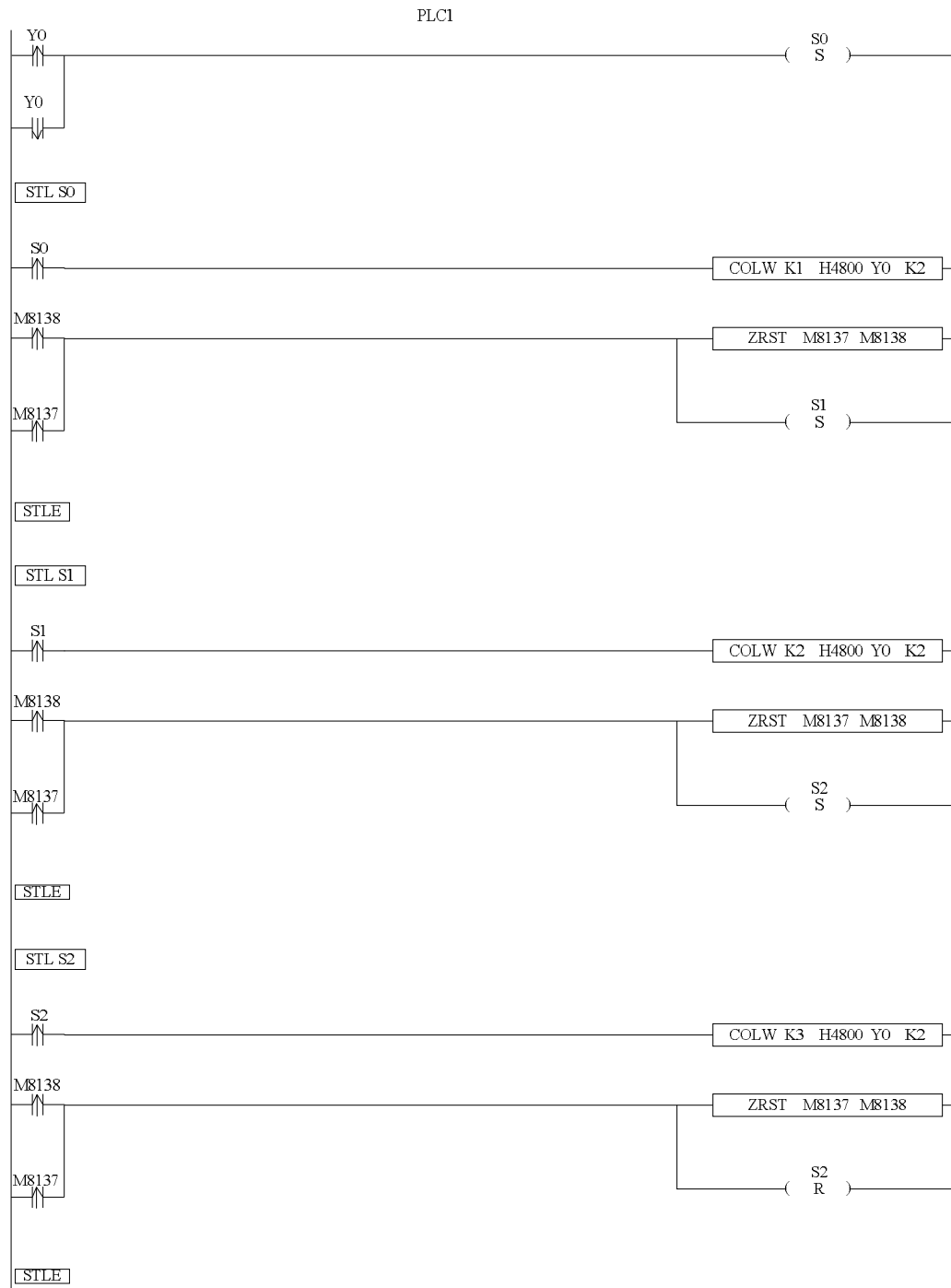

There are 3 STL in the program. Every STL is communication program of one slave. If one STL communication is successful, it jumps to the next STL. If not, it tries twice. If three times all fail, M8137 is ON and jump to the next STL. (This program uses serial port 2, if it is other serial port, please see appendix 1 for communication flag bit)

Method 2: use BLOCK to make the program

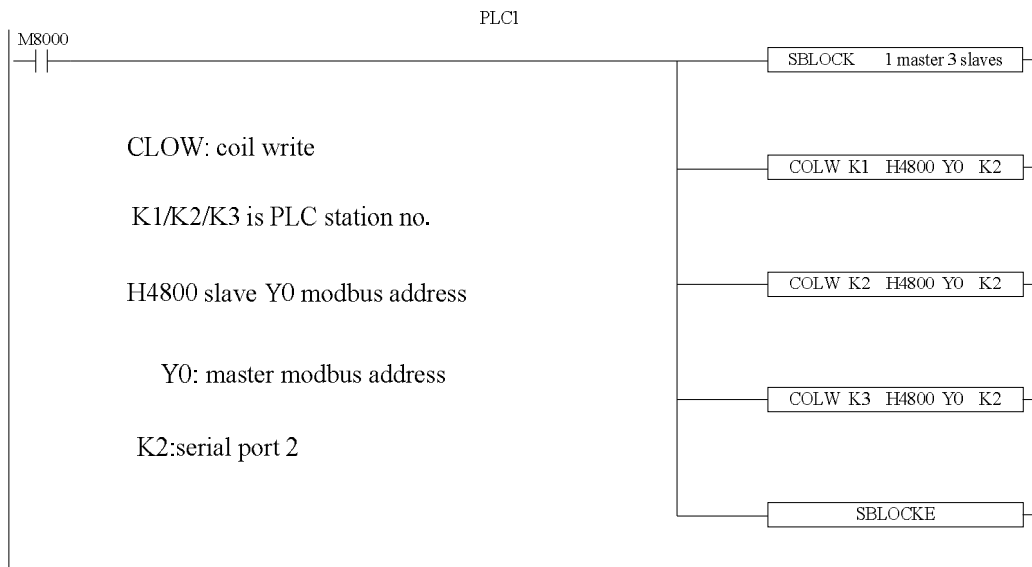

M8000 is always ON coil, the master will keep on writing the Y0 state to slave Y0. (Please refer to chapter 10 for BLOCK function).

Method 3: use broadcast function

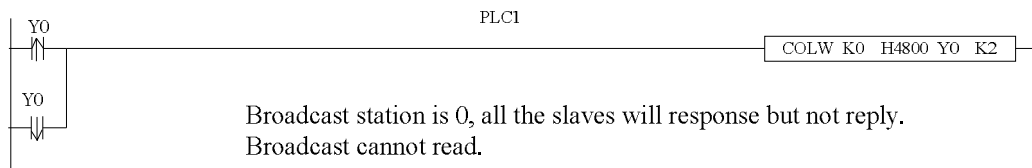

When master Y0 state changes, it broadcasts the state to all the slaves. The synchronization is better than method 1 and 2.

## 7-3. FREE FORMAT COMMUNICATION

### 7-3-1. Communication mode

Free format communication transfer data in the form of data block, each block can transfer 128 bytes at most.

Free format communication mode

Free format is free protocol communication. Now many devices support RS232 or RS485, but the communication protocol is different. For example, XINJE PLC is Modbus protocol, some temperature controllers use special protocol. If PLC needs to read temperature, it can send data according to the temperature controller protocol.

Note:

- Port1, Port2 or Port3 can support free format communication, but free format usually needs to change the serial port parameters. Port 1 parameter cannot be changed, so it is not recommended to use port 1.
- In free format mode, FD8220 (port 2) or FD8230 (port 3) should set to be 255 (FF)
- Baud Rate: 300bps~115.2Kbps
- Data Format
  - Data Bit: 7bits, 8bits
  - Parity: Odd, Even, No Check
  - Stop bit: 1 bit, 2 bits
- Start bit: 1 bit
  - Stop bit: 1 bit
  - User can set a start/stop bit, then PLC will automatically add this start/stop bit when sending data; remove this start/stop bit when receiving data.
  - Start bit and stop bit can be seemed as header and frame end. If slave station has started and stop bit, they can be set in software or protocol.
- Communication Format: 8 bits, 16 bits
  - If choose 8 bits buffer format to communicate, in the communication process, the high bytes are invalid, PLC only use the low bytes to send and receive data.
  - If choose 16 bits buffer format to communicate, when PLC is sending data, PLC will send low bytes before sending higher bytes

### 7-3-2. Suitable condition

When can we use free format communication?

In the last chapter, XINJE PLC communicates with temperature controller, the controller use own protocol. The protocol said that 4 characters should be sent when temperature read/write.

| Character | Meaning         |
|-----------|-----------------|
| :         | Data start      |
| R         | Read function   |
| T         | Temperature     |
| CR        | Enter, data end |

PLC needs to send the ASCII code of above character to the controller.

The ASCII code of characters:

| Character | ASCII code |
|-----------|------------|
| :         | 3A         |
| R         | 52         |
| T         | 54         |
| CR        | 0D         |

PLC cannot use Modbus protocol to communicate with the controller. The free format communication should be used. Please see the details in the following chapter.

### 7-3-3. Instruction form

#### > Send data [SEND]

#### 1、 Summary

Write the local specified data to the specified station's specified ID;

| Send data [SEND]     |                               |                      |                         |
|----------------------|-------------------------------|----------------------|-------------------------|
| 16 bits instruction  | SEND                          | 32 bits instruction  | -                       |
| Execution Condition  | Normally ON/OFF 、 rising edge | Suitable Models      | XC2, XC3, XC5, XCM, XCC |
| Hardware Requirement | -                             | Software Requirement | -                       |

#### 2、 Operands

| Operands | Function  | Type        |
|----------|---|-------------|
| S1       | Specify the start address of local sending data               | 16bits, BIN |
| S2       | Specify the send character quantity or soft component address | 16bits, BIN |

|   |                             |             |
|---|-----------------------------|-------------|
| n | Specify the serial port no. | 16bits, BIN |
|---|-----------------------------|-------------|

### 3、Suitable soft components

| Word | Operands | System |    |    |    |    |    |    |    | constant | module |    |    |
|------|----------|--------|----|----|----|----|----|----|----|----------|--------|----|----|
|      |          | D      | FD | ED | TD | CD | DX | DY | DM | DS       | K/H    | ID | QD |
| S1   | • •      |        | •  | •  |    |    |    |    |    |          |        |    |    |
| S2   | • •      |        | •  | •  |    |    |    |    |    | •        |        |    |    |
| n    | •        |        |    |    |    |    |    |    |    | K        |        |    |    |

#### Function

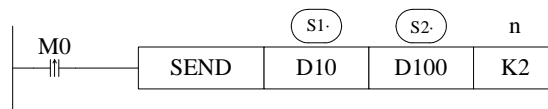

- Data send instruction, send data on the rising edge of M0;
- Serial port: K2~K3
- When sending data, set “sending” flag M8132 (COM2) ON

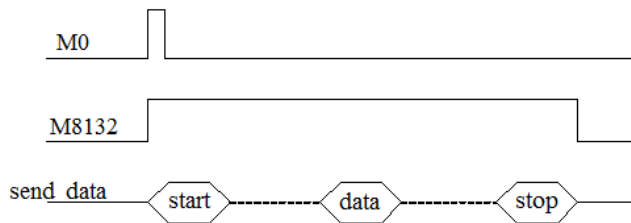

#### Receive Date [RCV]

##### 1、Summary

Write the specified station's data to the local specified ID;

| Receive data [RCV]   |                             |                      |                         |
|----------------------|-----------------------------|----------------------|-------------------------|
| 16 bits instruction  | RCV                         | 32 bits instruction  | -                       |
| Execution Condition  | Normally ON/OFF、rising edge | Suitable Models      | XC2, XC3, XC5, XCM, XCC |
| Hardware Requirement | -                           | Software Requirement | -                       |

##### 2、Operands

| Operands | Function  | Type        |
|----------|---|-------------|
| S1       | Specify the start address of local receiving data | 16bits, BIN |

|    |   |             |
|----|---|-------------|
| S2 | Specify the receive characters quantity or soft component address | 16bits, BIN |
| n  | Specify the serial port no.                                       | 16bits, BIN |

### 3、Suitable soft components

| Word | Operands | System |    |    |    |    |    |    |    | constant | module |    |    |
|------|----------|--------|----|----|----|----|----|----|----|----------|--------|----|----|
|      |          | D      | FD | ED | TD | CD | DX | DY | DM | DS       | K/H    | ID | QD |
| S1   |          | •      | •  |    | •  | •  |    |    |    |          |        |    |    |
| S2   |          | •      | •  |    | •  | •  |    |    |    |          | •      |    |    |
| n    |          |        |    |    |    |    |    |    |    |          | •      |    |    |

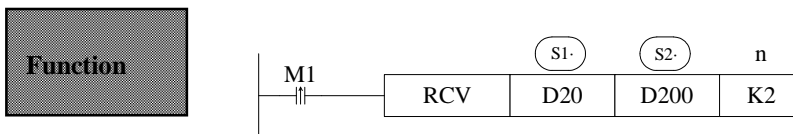

- Data receive instruction, receive data on the rising edge of M0;
- Serial port: K2~K3
- When receiving data, set “receiving” flag M8134 ON

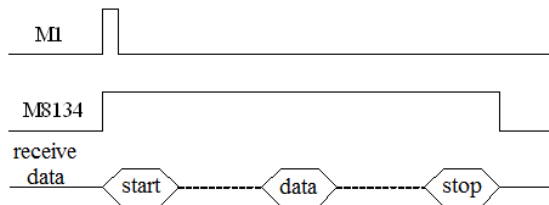

---

※1: If you require PLC to receive but not send, or receive before send, you need to set the communication timeout to 0ms

---

## Release serial port [RCVST]

### 1、 Summary

Release the serial port

| Receive data [RCVST] |                               |                      |                         |
|----------------------|-------------------------------|----------------------|-------------------------|
| 16 bits instruction  | RCVST                         | 32 bits instruction  | -                       |
| Execution Condition  | Normally ON/OFF 、 rising edge | Suitable Models      | XC2, XC3, XC5, XCM, XCC |
| Hardware Requirement | -                             | Software Requirement | -                       |

### 2、 Operands

| Operands | Function                    | Type        |
|----------|-----------------------------|-------------|
| n        | Specify the serial port no. | 16bits, BIN |

### 3、 Suitable soft components

| Word | Operands | System |    |    |    |    |    |    |    |    | constant | module |    |
|------|----------|--------|----|----|----|----|----|----|----|----|----------|--------|----|
|      |          | D      | FD | ED | TD | CD | DX | DY | DM | DS | K/H      | ID     | QD |
|      | n        |        |    |    |    |    |    |    |    |    | K        |        |    |

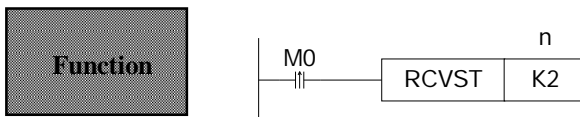

- RCVST instruction, it executes once at the rising edge of M0
- Serial port: K2, K3
- When releasing the serial port, set OFF M8134 (port 2 receiving sign bit), set ON M8135 (port 2 receive uncompleted sign bit)
- In free format communication mode, if there is no timeout or the timeout time is too long, please use RCVST to release the serial port.

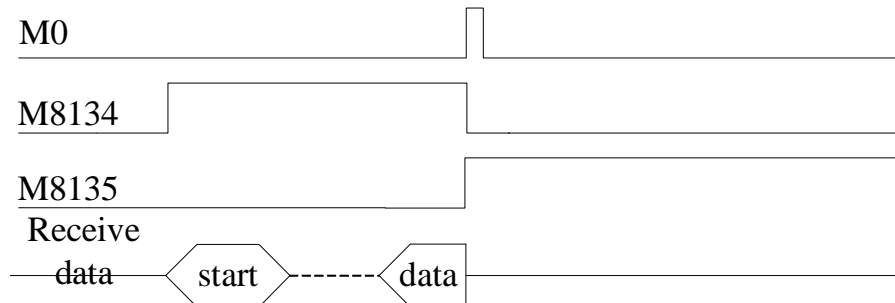

### 7-3-4. Free format communication application

Here we use the example in chapter 7-3-2 (XINJE PLC and temperature controller) to explain the application.

Operation:

1. Connect all the hardware wires.
2. Set the PLC serial port parameters as the controller communication parameters. (PLC station no. is 255 in free format communication). Please restart the PLC after setting the parameters.
3. Make the program as the protocol in chapter 7-3-2.

Read temperature send data : R T CR

: ---- start  
R ---- read  
T ---- temperature  
CR ---- enter, end

Two methods to making the program:

A. Normal method

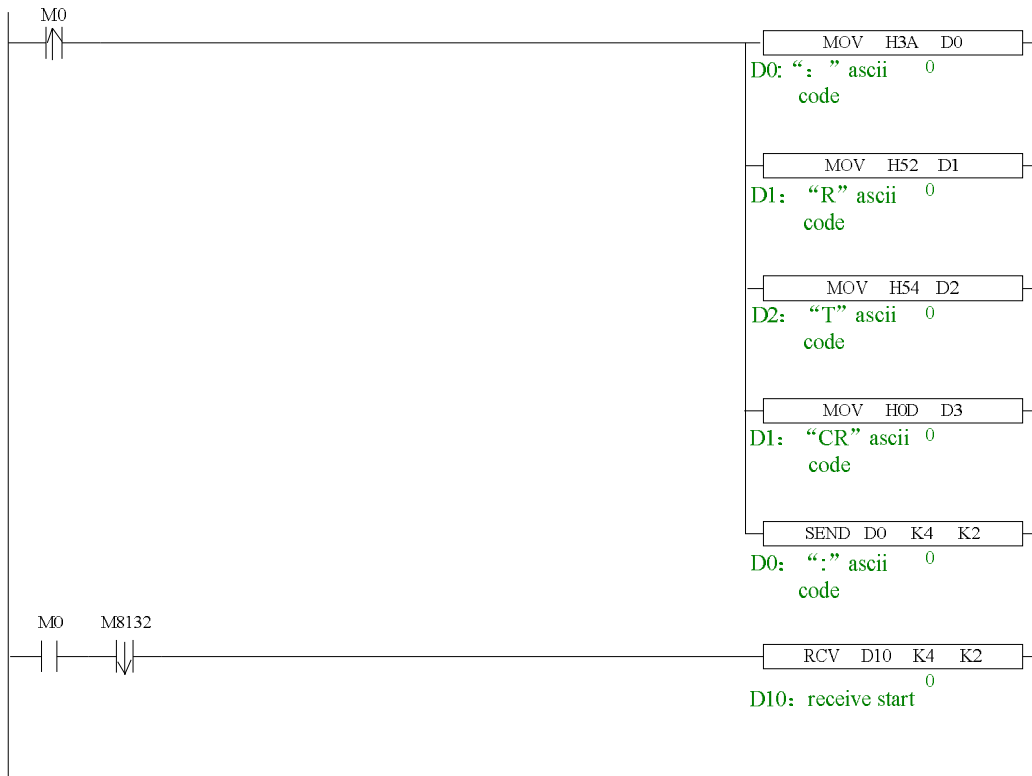

If it needs to use STL, please refer to Modbus example program. Switch the STL by serial port communication sign bit.

## B. use BLOCK to make the program

Send data:

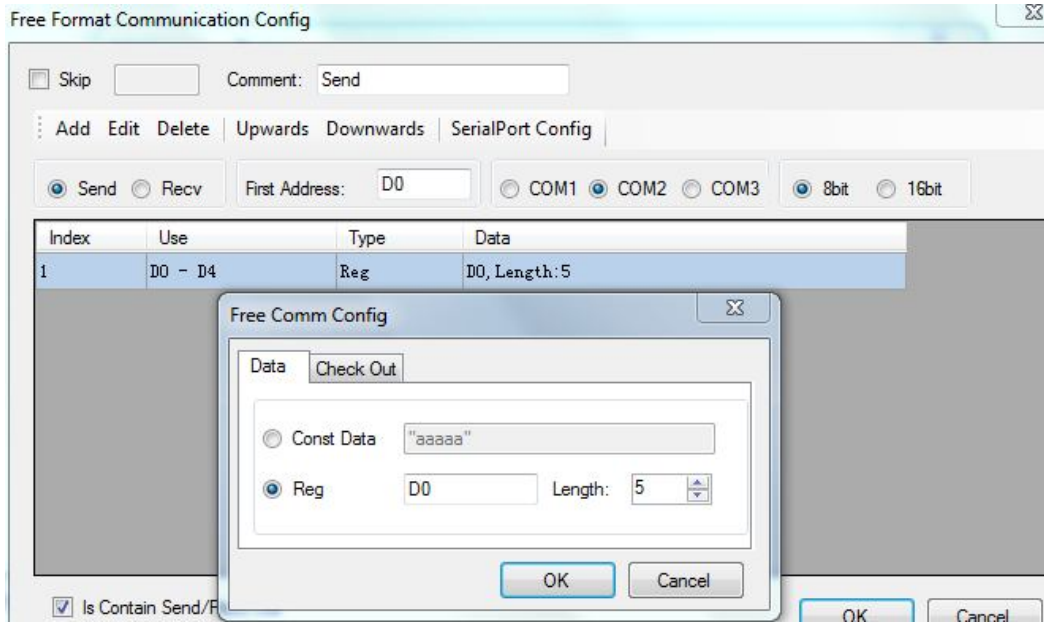

Receive data

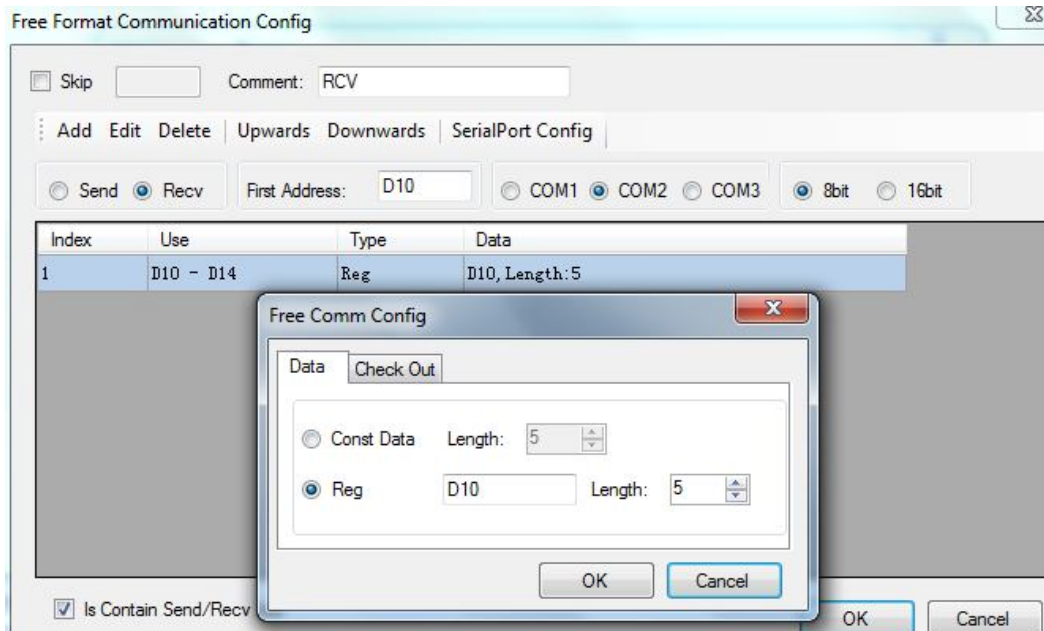

Program:



M8000 is always ON coil; PLC will keep on reading the temperature.

When the PLC communicate with other device, please use serial port debug tool to monitor the data. Then make the free format protocol as the data format in the tool. This method can save time and easy to do.

## 7-4. CAN Bus Functions

### 7-4-1. Brief Introduction of CAN-bus

XC5 series PLC support CANbus bus function. Below we will give some basic concept on CANbus;

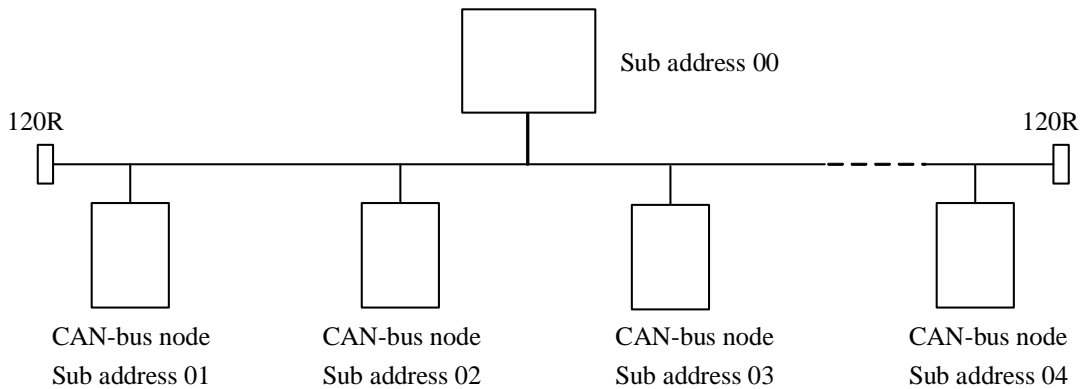

**CAN** (Controller Area Network) belongs to industrial area bus category. Compared with common communication bus, CAN bus data communication has performance of outstanding dependability, real time ability and flexibility.

**CAN** controller works under multi-master format. In the network, each node can send data to bus according to the bus visit priority. These characters enable each node in CAN bus network to have stronger data communication real time performance, and easy to construct redundant structure, improve the system's dependability and flexibility.

In CANBUS network, any node can initiatively send message at any time to any other node, no master and no slave. Flexibility communication, it's easy to compose multi-device backup system, distributing format monitor, control system. To fulfill different real time requirement, the

nodes can be divided to be different priority level. With non-destroy bus adjudication technology, when two nodes send message to the network at the same time, the low level priority node initiatively stop data sending, while high level priority node can continue transferring data without any influence. So there is function of node to node, node to multi-node, bureau broadcasting sending/receiving data. Each frame's valid byte number is 8, so the transfer time is short, the probability ratio is low.

#### 7-4-2. External Wiring

CAN-Bus Communication Port: CAN+, CAN-

The wiring among each node of CAN bus is shown in the following graph; at the two ends, add 120 ohm middle-terminal resistors.

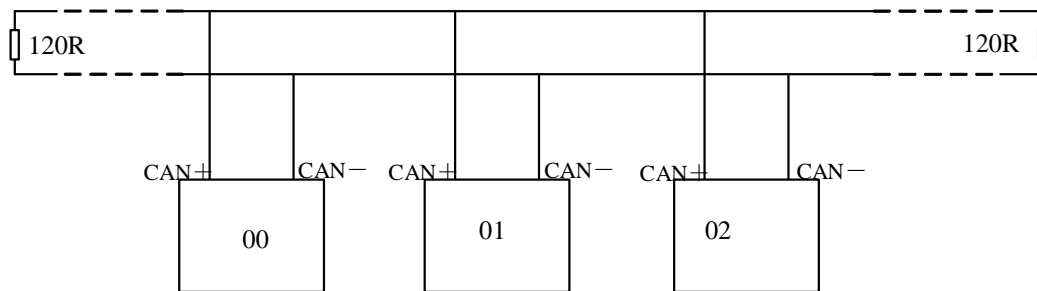

#### 7-4-3. CAN Bus Network Form

There are two forms of CAN bus network: one is instructions communication format; the other is internal protocol communication format. These two forms can work at the same time

➤ Instructions communication format

This format means, in the local PLC program, via CAN-bus instructions, execute bit or word reading/writing with the specified remote PLC.

➤ Internal protocol communication format

This format means, via setting of special register, via configure table format, realize allude with each other among PLC's certain soft component's space. In this way, PLC can share the source in CAN-bus network.

## 7-4-4. CAN-bus Instructions

### ➤ Read Coil [CCOLR]

#### 1、 Instruction Description

Function: Read the specified station's specified coil status into the local specified coil.

| Read Coil [CCOLR]    |  |                      |          |
|----------------------|--|----------------------|----------|
| 16 bits instruction  | CCOLR                                  | 32 bits instruction  | -        |
| Execution Condition  | Normally ON/OFF, rising edge activates | Suitable Models      | XC5, XCC |
| Hardware Requirement | -                                      | Software Requirement | -        |

#### 2、 Operands

| Operands | Function  | Type        |
|----------|---|-------------|
| S1       | Specify remote communication station no. or soft component's address; | 16bits, BIN |
| S2       | Specify the remote coil's start address or soft component's address;  | 16bits, BIN |
| S3       | Specify the coil quantity or soft component's address;                | 16bits, BIN |
| D        | Specify the local receive coil's start address                        | bit         |

#### 3、 Suitable Soft Components

| Word | Operands | System |    |    |    |    |    |    |    | Constant | Module |    |    |
|------|----------|--------|----|----|----|----|----|----|----|----------|--------|----|----|
|      |          | D      | FD | ED | TD | CD | DX | DY | DM | DS       | K/H    | ID | QD |
|      | S1       | •      | •  |    | •  | •  |    |    |    |          | •      |    |    |
|      | S2       | •      | •  |    | •  | •  |    |    |    |          | •      |    |    |
|      | S3       | •      | •  |    | •  | •  |    |    |    |          | •      |    |    |

| Bit | Operands | System |   |   |   |   |   |     |
|-----|----------|--------|---|---|---|---|---|-----|
|     |          | X      | Y | M | S | T | C | Dnm |
|     | D        | •      | • | • | • | • | • |     |

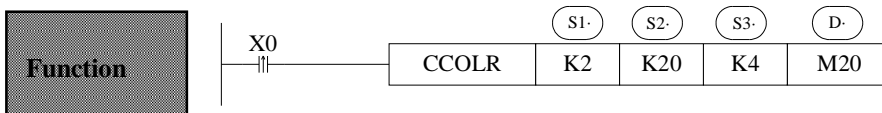

- Execute CCOLR instruction when X0 changes from OFF to ON; read the four coils data of remote station 2, coil's start address K20 to local coils M20~M23.

**Write the Coil [CCOLW]**

1、 Summary

Write the local specified multi-coils status into the specified station's specified coils;

| Write the coil [CCOLW] |                               |                      |          |
|------------------------|-------------------------------|----------------------|----------|
| 16 bits instruction    | CCOLW                         | 32 bits instruction  | -        |
| Execution Condition    | Normally ON/OFF 、 rising edge | Suitable Models      | XC5, XCC |
| Hardware Requirement   | -                             | Software Requirement | -        |

2、 Operands

| Operands | Function   | Type        |
|----------|--|-------------|
| D1       | Specify remote communication station no. or soft component's number; | 16 bit, BIN |
| D2       | Specify the remote coil's start address or soft component's number;  | 16 bit, BIN |
| D3       | Specify the coil quantity or soft component's number;                | 16 bit, BIN |
| S        | Specify the local receive coil's start address                       | bit         |

3、 Suitable soft components

| Word | Operands | System |    |    |    |    |    |    |    | constant | module |    |    |
|------|----------|--------|----|----|----|----|----|----|----|----------|--------|----|----|
|      |          | D      | FD | ED | TD | CD | DX | DY | DM | DS       | K/H    | ID | QD |
|      | S1       | •      | •  |    | •  | •  |    |    |    |          | •      |    |    |
|      | S2       | •      | •  |    | •  | •  |    |    |    |          | •      |    |    |
|      | S3       | •      | •  |    | •  | •  |    |    |    |          | •      |    |    |

| Bit | Operands | System |   |   |   |   |   |     |
|-----|----------|--------|---|---|---|---|---|-----|
|     |          | X      | Y | M | S | T | C | Dnm |
|     | D        | •      | • | • | • | • | • |     |

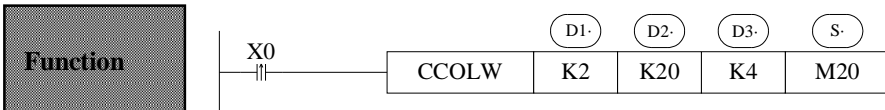

- Execute CCOLW instruction when X0 changes from OFF to ON; write the local M20~M23 to the remote station no.2, coil's start address K20, coil quantity is 4.

**Read Register [CREGR]**

1、 Summary

Read the specified station's specified register to the local specified register;

| Read register [CREGR] |                              |                      |          |
|-----------------------|------------------------------|----------------------|----------|
| 16 bits instruction   | CREGR                        | 32 bits instruction  | -        |
| Execution Condition   | Normally ON/OFF、 rising edge | Suitable Models      | XC5, XCC |
| Hardware Requirement  | -                            | Software Requirement | -        |

2、 Operands

| Operands | Function  | Type        |
|----------|---|-------------|
| D1       | Specify remote communication station no. or soft component's number;    | 16bits, BIN |
| D2       | Specify the remote register's start address or soft component's number; | 16bits, BIN |
| D3       | Specify the register quantity or soft component's number;               | 16bits, BIN |
| S        | Specify the local receive coil's start address                          | 16bits, BIN |

3、 Suitable soft components

| Word | Operands | System |    |    |    |    |    |    |    | constant | module |    |    |
|------|----------|--------|----|----|----|----|----|----|----|----------|--------|----|----|
|      |          | D      | FD | ED | TD | CD | DX | DY | DM | DS       | K/H    | ID | QD |
| S1   |          | •      | •  |    | •  | •  |    |    |    |          | •      |    |    |
| S2   |          | •      | •  |    | •  | •  |    |    |    |          | •      |    |    |
| S3   |          | •      | •  |    | •  | •  |    |    |    |          | •      |    |    |
| D    |          | •      |    |    | •  | •  |    |    |    |          |        |    |    |

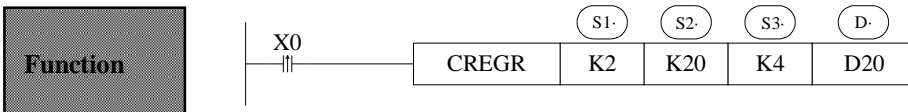

- Execute CREGR instruction when X0 changes from OFF to ON; read the remote station no.2, coil's start address K20 (4 coils) to the local D20~D23

**Write the Register [CREGW]**

1、 Summary

Write the specified local input register to the specified station's specified register;

| Write the register [CREGW] |                              |                      |          |
|----------------------------|------------------------------|----------------------|----------|
| 16 bits instruction        | CREGW                        | 32 bits instruction  | -        |
| Execution Condition        | Normally ON/OFF、 rising edge | Suitable Models      | XC5, XCC |
| Hardware Requirement       | -                            | Software Requirement | -        |

2、 Operands

| Operands | Function  | Type        |
|----------|---|-------------|
| D1       | Specify remote communication station no. or soft component's number;    | 16bits, BIN |
| D2       | Specify the remote register's start address or soft component's number; | 16bits, BIN |
| D3       | Specify the register quantity or soft component's number;               | 16bits, BIN |
| S        | Specify the local receive coil's start address                          | 16bits, BIN |

3、 Suitable soft components

| Word | Operands | System |    |    |    |    |    |    |    | constant | module |    |    |
|------|----------|--------|----|----|----|----|----|----|----|----------|--------|----|----|
|      |          | D      | FD | ED | TD | CD | DX | DY | DM | DS       | K/H    | ID | QD |
| S1   |          | •      | •  |    | •  | •  |    |    |    |          | •      |    |    |
| S2   |          | •      | •  |    | •  | •  |    |    |    |          | •      |    |    |
| S3   |          | •      | •  |    | •  | •  |    |    |    |          | •      |    |    |
| D    |          | •      |    |    | •  | •  |    |    |    |          |        |    |    |

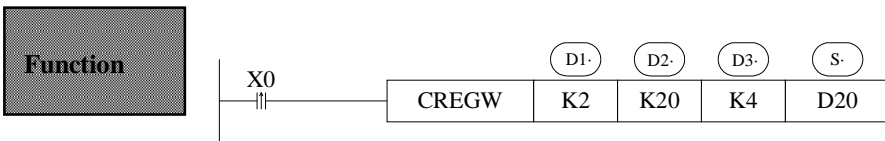

- Execute CREGW instruction when X0 changes from OFF to ON; write the local D20~D23 to the remote station no.2, coil's start address K20.

## 7-4-5. Communication Form of Internal Protocol

### Function

- Open/close the internal protocol communication function  
Set the value in register FD8350:  
0: do not use CAN internal protocol communication;  
1: use CAN internal protocol communication  
CAN internal protocol communication is default to open;
- Set the communication parameters  
Method 1: direct setting  
Step1. Add four configure items quantity separately: FD8360—read the bit items, FD8361—read the word items, FD8362—write the bit items, FD8363—write the word items  
Step2. Set each configure item's communication object, each item includes four parameters: remote station, remote object address, local object address, local quantity. The correspond registers are: FD8370~FD8373 represents item 1, FD8374~FD8377 represents item2.....FD9390~FD9393 represents item256; totally we can set 256 configure items; see the following table (communication setting).

### Communication Setting

| Item   | Function                     | Description  |
|--------|------------------------------|--|
| FD8350 | CAN communication mode       | 0 represents <b>not use</b> ; 1 represents internal protocol   |
| FD8351 | CAN baud rate                | See CAN baud rate setting table  |
| FD8352 | Self CAN station no.         | For CAN protocol using (the default value is 1)  |
| FD8354 | Configured sending frequency | The set value's unit is <b>ms</b> , represents "send every <b>ms</b> " if set to be 0, it means send every cycle, the default value is 5ms |
| FD8360 | Read bit number              |  |
| FD8361 | Read word number             |  |
| FD8362 | write bit number             |  |
| FD8363 | write word number            |  |
| FD8370 | Remote station address       | The item 1 configuration   |
| FD8371 | Remote object address        |  |
| FD8372 | Local object address         |  |
| FD8373 | Quantity                     |  |
| .....  | .....                        | .....  |
| FD9390 | Remote node's ID             | The item 256 configuration   |
| FD9391 | Remote node's object ID      |  |
| FD9392 | Local object's ID            |  |
| FD9393 | Number                       |  |

### Status Flag

|       |   |  |
|-------|---|--|
| M8240 | CAN self check error flag                             | Set 1 if error; set 0 if correct   |
| M8241 | Error flag of CAN configure                           | Set 1 if error; set 0 if correct   |
| M8242 | Automatically recover the control after CAN bus error | If set to be 1, then recover after error happens;<br>If set to be 1, then CAN stops working after error happens;<br>The default value is 1, this flag is not power-off retentive |

### Baud Rate Setting

| FD8351 value | Baud Rate (BPS) |
|--------------|-----------------|
| 0            | 1K              |
| 1            | 2K              |
| 2            | 5K              |
| 3            | 10K             |
| 4            | 20K             |
| 5            | 40K             |
| 6            | 50K             |
| 7            | 80K             |
| 8            | 100K            |
| 9            | 150K            |
| 10           | 200K            |
| 11           | 250K            |
| 12           | 300K            |
| 13           | 400K            |
| 14           | 500K            |
| 15           | 600K            |
| 16           | 800K            |
| 17           | 1000K           |

### Register Status

|       |   |   |
|-------|---|---|
| D8240 | CAN error information                       | 0: no error<br>2: initialize error<br>30: bus error<br>31: error alarm<br>32: data overflow |
| D8241 | The configure item no. which has error      | Show the first number of error configure item   |
| D8242 | Data package quantity sent every second     | -   |
| D8243 | Data package quantity received every second | -   |
| D8244 | CAN communication error count               | -   |

## 7-4-6. CAN Free Format Communication

Please set FD8350 to 2 for CAN free format communication

### ➤ CAN Sending [CSEND]

#### 1、Instructions Summary

Write the specified data from the unit to a specified address (data transfer in one unit)

| CAN Sending [CSEND]  |                             |                      |          |
|----------------------|-----------------------------|----------------------|----------|
| 16bits instruction   | CSEND                       | 32bits instruction   | -        |
| Executing Condition  | Normally ON/OFF、Rising edge | Suitable Models      | XC5, XCC |
| Hardware Requirement | -                           | Software Requirement | -        |

#### 2、Operands

| Operands | Function   | Type        |
|----------|--|-------------|
| S1       | specify the ID of sending data package                   | 16bits, BIN |
| S2       | specify the local sending data or soft component locally | 16bits, BIN |
| S3       | specify the byte number of sent data                     | 16bits, BIN |

### 3、Suitable soft components

| Word type | Operands | System |    |    |    |    |    |    |    | constant | module |    |    |
|-----------|----------|--------|----|----|----|----|----|----|----|----------|--------|----|----|
|           |          | D      | FD | ED | TD | CD | DX | DY | DM | DS       | K/H    | ID | QD |
| S1        | •        | •      |    |    | •  | •  |    |    |    |          | •      |    |    |
| S2        | •        | •      |    |    | •  | •  |    |    |    |          |        |    |    |
| S3        | •        | •      |    |    | •  | •  |    |    |    |          | •      |    |    |

#### Functions and Actions



- Instruction for data sending, send data at every rising edge of M0
- ID number of sending data package is 100, 4 bytes data, the first ID is in D0
- 8 bits data transfer: the transferred data is: D0L、D1L、D2L、D3L (D0L means the low byte of D0)
- 16 bits data transfer: the transferred data is: D0L、D0H、D1L、D1H (D0H means the high byte of D0)



- The ID of sending data package is specified by D10, the data number is specified by D20, the first ID is in D0;
- 8 bits data transfer: the transferred data is: D0L、D1L、D2L、D3L (D0L means the low byte of D0)
- 16 bits data transfer: the transferred data is: D0L、D0H、D1L、D1H (D0H means the high byte of D0)
- Standard Frame: the valid bits of the data package ID number that is specified by D10 is the low 11 bits, the left bits are invalid;
- The expansion frame: the valid bits of the data package ID number that is specified by D10 is the low 29 bits, the left bits are invalid;
- The maximum data bits specified by D20 is 8, if exceeds 8, the instruction will send only 8 bits;

**> CAN Receive [CRECV]**

1、Instructions Summary

Write the specified data in one unit to a specified address in another unit (data transfers between different units)

| CAN Receive [CRECV]  |                               |                      |          |
|----------------------|-------------------------------|----------------------|----------|
| 16 bits instruction  | CRECV                         | 32 bits instruction  | -        |
| Executing Condition  | Normally ON/OFF 、 Rising edge | Suitable Models      | XC5, XCC |
| Hardware Requirement | -                             | Software Requirement | -        |

2、Operands

| Operands | Function   | Type        |
|----------|--|-------------|
| S1       | specify the ID number to receive the data package              | 16bits, BIN |
| S2       | specify the local receiving soft component start ID            | 16bits, BIN |
| S3       | specify the byte quantity of received data                     | 16bits, BIN |
| S4       | specify the soft component's start ID number of ID filter code | 16bits, BIN |

3、Suitable soft components

| Word Type | Operands | System |    |    |    |    |    |    |    | Constant | Module |    |    |
|-----------|----------|--------|----|----|----|----|----|----|----|----------|--------|----|----|
|           |          | D      | FD | ED | TD | CD | DX | DY | DM | DS       | K/H    | ID | QD |
| S1        |          | •      | •  |    | •  | •  |    |    |    |          |        |    |    |
| S2        |          | •      | •  |    | •  | •  |    |    |    |          |        |    |    |
| S3        |          | •      | •  |    | •  | •  |    |    |    |          |        |    |    |
| S4        |          | •      |    |    |    |    |    |    |    |          |        |    |    |

**Functions and Actions**

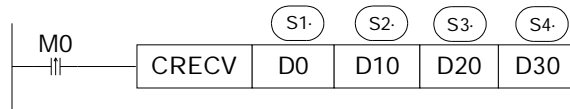

- The 32 bits memory combined by [D1, D0] (D0 is low byte, D1 is high byte) is used to stock ID number of the received data package. The received data length is stored in D20. The data content is stored in registers start from D10. D30 specifies the received ID filter code; if the received data doesn't fit the filter codes, then it will keep the RECV status;
- ID filter code: D30 specifies the start address of ID filter codes; the instruction specifies two groups of filter codes, occupy D30~D37;

| Filter Code     | Memory   | Description  | Example  |
|-----------------|----------|--|--|
| The first group | D31, D30 | D30 low bytes, D31 high bytes, they compose a 32 bits mask code    | D30=0xFFFF, D31=0x0000, then the mask code is 0x0000FFFF<br>D30=0x1234, D31=0x0000, then filter value is 0x00001234<br>If ID and 0x0000FFFF equals 0x00001234, the pass the first group of filter. If the ID pass any of two groups, the allow the reception |
|                 | D33, D32 | D32 low bytes, D33 high bytes, they compose a 32 bits filter value |  |
| The first group | D35, D34 | D34 low bytes, D35 high bytes, they compose a 32 bits mask code    |  |
|                 | D37, D36 | D36 low bytes, D37 high bytes, they compose a 32 bits filter value |  |

- Standard/ expansion frame: the setting of FD8358 has no effect to reception. If the data frame fulfills ID mask codes, the standard frame and the expansion frames can be all received. When receive the standard frame, the ID bits is 11, but will still occupy the 32 bits memory combined by [D1,D0]
- 8 bits data transfer: the transfer data is: D0L、D1L、D2L、D3L.....(D0L means the low byte of D0)
- 16 bits data transfer: the transfer data is: D0L、D0H、D1L、D1H.....(D0H means the high byte of D0)

➤ **Relate Special Soft Components List**

1. System FD8000 Setting

| ID     | Function      | Description   |
|--------|---------------|---|
| FD8350 | CAN Mode      | 0: not usable<br>1: XC-CAN network<br>2: Free format <b>FREE</b>  |
| FD8351 | CAN baud rate | 0, 1KBPS initial value, actual is 5KBPS.<br>1, 2KBPS initial value, actual is 5KBPS.<br>2, 5KBPS initial value<br>3, 10KBPS initial value<br>4, 20KBPS initial value<br>5, 40KBPS initial value<br>6, 50KBPS initial value<br>7, 80KBPS initial value<br>8, 100KBPS initial value<br>9, 150KBPS initial value<br>10, 200KBPS initial value<br>11, 250KBPS initial value |

|        |                         |   |
|--------|-------------------------|---|
|        |                         | 12, 300KBPS initial value<br>13, 400KBPS initial value<br>14, 500KBPS initial value<br>15, 600KBPS initial value<br>16, 800KBPS initial value<br>17, 1000KBPS initial value |
| FD8358 | CAN free format mode    | low 8 bits: 0-standard frame .<br>low 8 bits: 1-expansion frame<br>high 8 bits: 0-8 bits data store<br>high 8 bits: 1-16 bits data store                                    |
| FD8359 | CAN accept timeout time | for free format using, unit: ms   |
|        | CAN send timeout time   | fixed to be 5ms   |

## 2. System M8000 flag

| ID    | Function                             | Description  |
|-------|--------------------------------------|--|
| M8240 | CAN error flag                       | ON: error happens<br>OFF: normal<br>if set M8242 as ON, and manually set M8240 as ON, this will enable CAN reset |
| M8241 | CAN node dropped off flag            | XC-CAN mode valid<br>ON: certain node/nodes are dropped off<br>OFF: Normal                                       |
| M8242 | do reset or not if CAN error happens | ON: CAN reset automatically when error happens<br>OFF: take no operation when error happens                      |
| M8243 | CAN send/accept finished flag        | FREE mode valid<br>ON: receive/accept finish<br>reset ON automatically when starting to send/accept              |
| M8244 | CAN send/accept timeout flag         | FREE mode valid<br>ON: send/accept timeout<br>Set OFF automatically when starting to send/accept                 |

## 3. System D8000

| ID    | Function              | Description   |
|-------|-----------------------|---|
| D8240 | CAN error information | 0: no error<br>2: initializing error<br>30: CAN bus error<br>31: error alarm<br>32: data overflow |

|       |   |   |
|-------|---|---|
| D8241 | configure item number when error happens  | XC-CAN valid  |
| D8242 | data package number sent every second     | both XC-CAN and FREE modes are valid  |
| D8243 | data package number accepted every second | both XC-CAN and FREE modes are valid  |
| D8244 | CAN communication error counter           | correspond with M8240 at every CAN error, M8240 will be set ON one time, D8244 increase 1 |

**Note:** when D8240 is not zero, please try the follow operations:

1. Check the wiring
2. Decrease baud rate or increase sending frequency

### Applications

Example 1: instruction communication

PLC station 1 and PLC station 2 communicate with each other through CAN instructions.

Program: (1) M0 is ON, send D100 of PLC station 1 to D20 of PLC station 2 (Y0 and Y2 is ON)

(2) M4 is ON, send D4000 of PLC station 2 to D0 of PLC station 1.

Ladder chart:

PLC station 1:

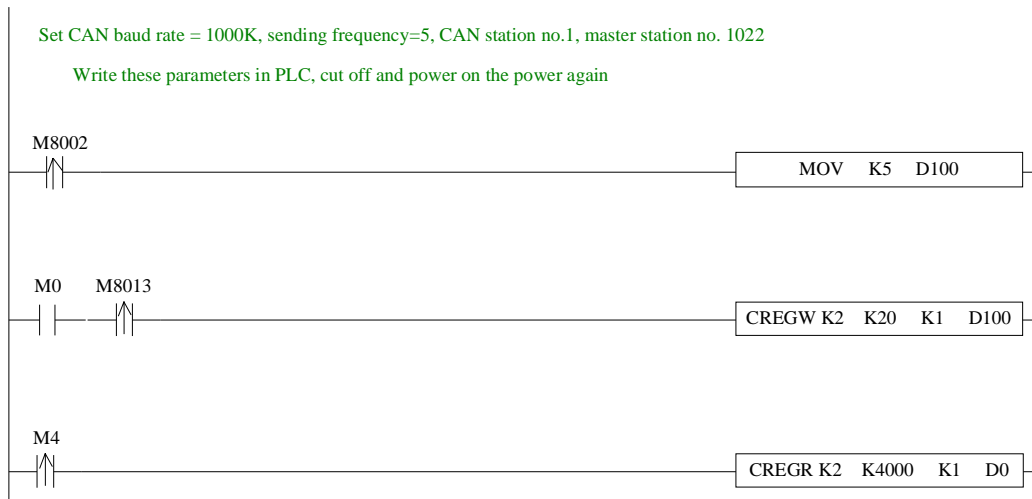

PLC station 2:

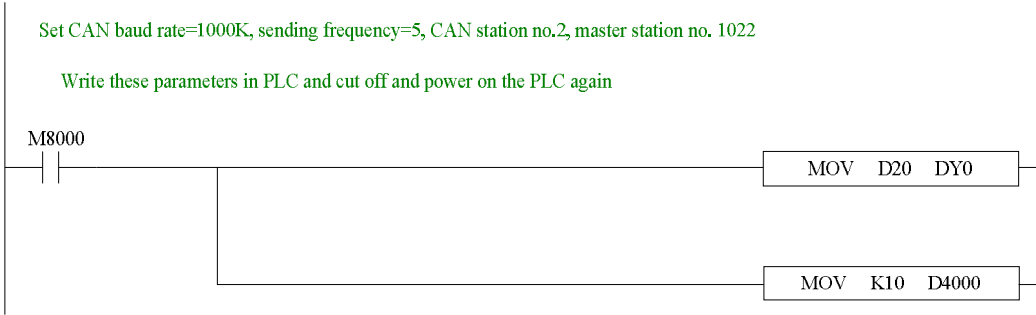

**Example 2: Internal protocol**

PLC station 1 and station 2 communicate with each other through CAN internal communication mode.

- Program: (1) send (D4000, D4001) of station 2 to (D0, D1) of station 1
- (2) send M0 state of station 1 to M0 of station 2, show the M0 state in Y0 of station 2
- (3) set on M0 when station 1 power on

Programming and ladder chart:

- (1) Open XCPpro software, click  CAN , and configure station 1.

send M0 state of station 1 to M0 of station 2

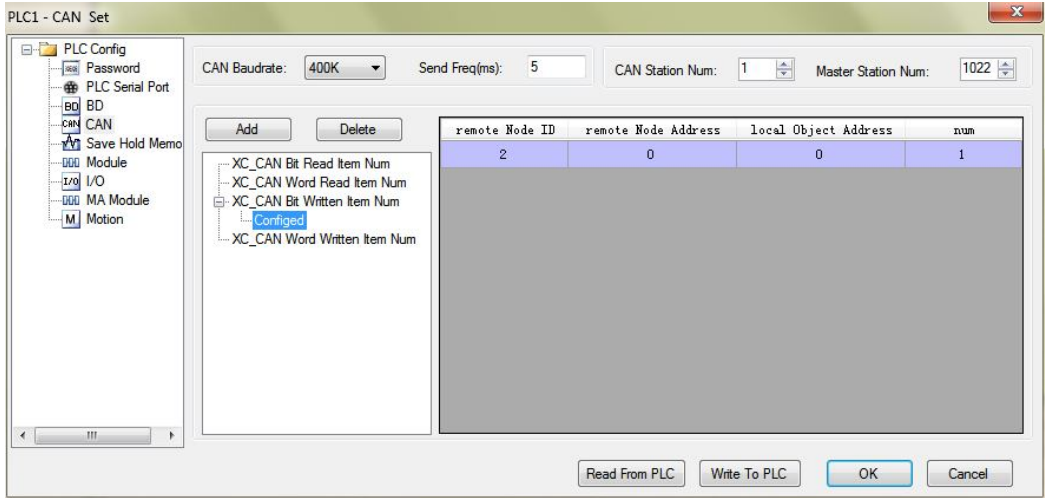

set on M0 when station 1 power on



(1) Open XCPpro software, click  CAN , and configure station 2.

send (D4000, D4001) of station 2 to (D0, D1) of station 1

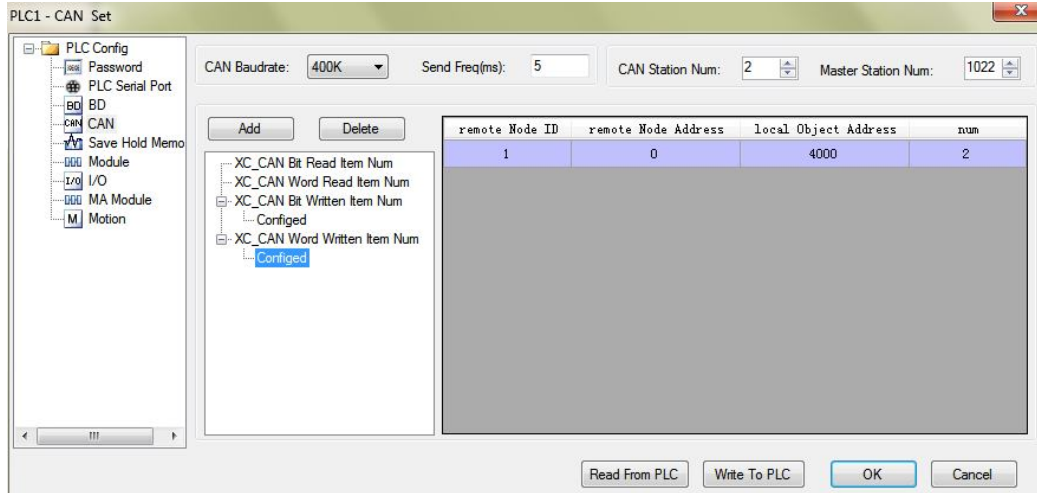

send M0 state of station 1 to M0 of station 2, show the M0 state in Y0 of station 2

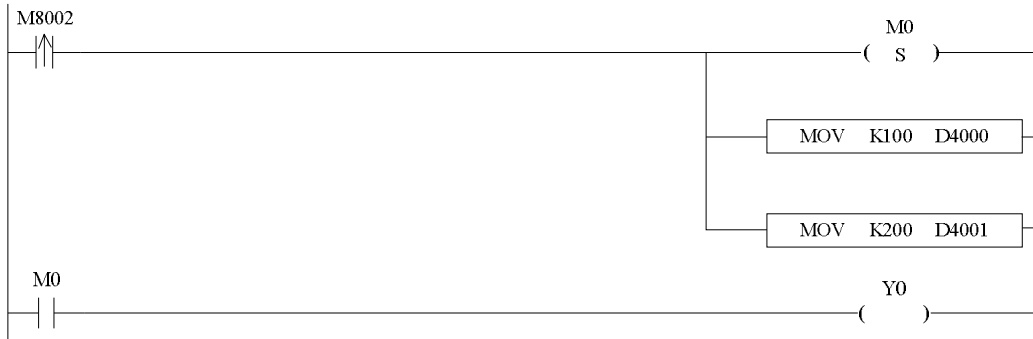

Example 3: Free format (please set FD8350 to 2 first)

Two Xinje PLCs communicate with each other through CAN free format mode

Program: (1) PLC station 1 sends the data package ID100 (4 bytes starts from D4000) every 1s

(2) When M0 is ON, PLC station 2 receives data package ID100 (4 bytes, ID filter code is defaulted), then save the data in register starts from D4000.

Ladder chart:

PLC station 1:

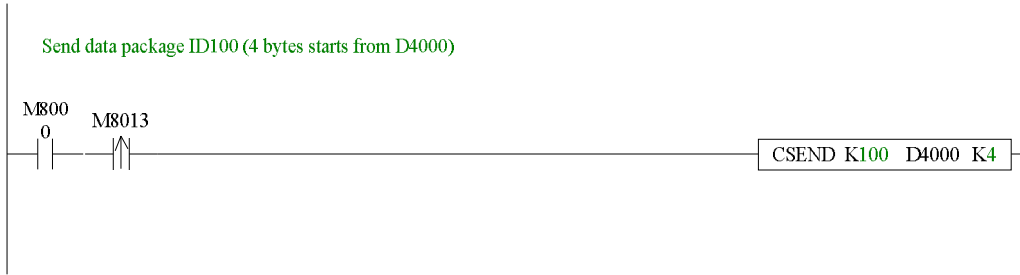

PLC station 2:

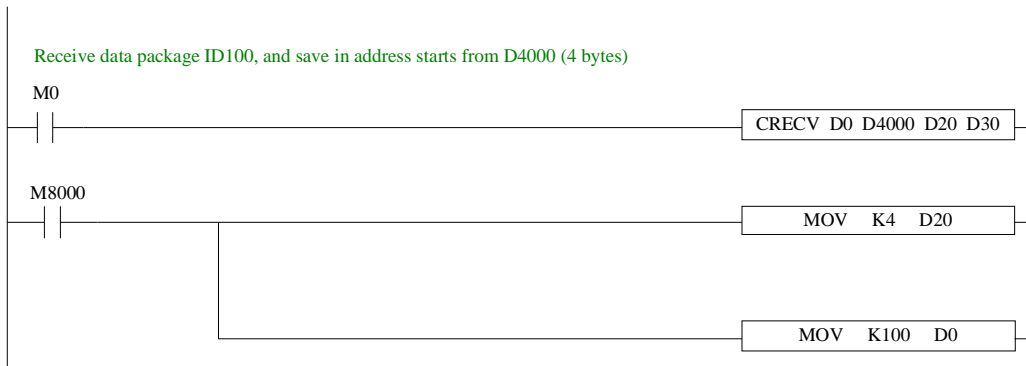

# 8 PID Control Function

---

In this chapter, we mainly introduce the applications of PID instructions for XC series PLC basic units, including: call the instructions, set the parameters, items to notice, sample programs etc.

8-1. Brief Introduction of the Functions

8-2. Instruction Formats

8-3. Parameter Setting

8-4. Auto Tune Mode

8-5. Advanced Mode

8-6. Application Outlines

8-7. Sample Programs

## 8-1. Brief Introductions of the Functions

PID instruction and auto tune function are added into XC series PLC basic units (Version 3.0 and above). Via auto tune method, users can get the best sampling time and PID parameters and improve the control precision.

The previous versions can not support PID function on basic units unless they extend analog module or BD cards. PID instruction has brought many facilities to the users.

- The output can be data form **D** and on-off quantity **Y**, user can choose them freely when program.
- Via auto tune, users can get the best sampling time and PID parameters and improve the control precision.
- User can choose positive or negative action via software setting. The former is used to heating control; the latter is used to cooling control.
- PID control separates the basic units with the expansions; this improves the flexibility of this function.
- A new PID algorithm-critical oscillation is added in v3.3 and higher version of PLC.

For temperature control object:

Step response method: the PID auto tune will start when current temperature of object is equal to ambient temperature.

Critical oscillation method: the PID auto tune will start at any temperature.

## 8-2. Instruction Forms

### 1、Brief Introductions of the Instructions

Execute PID control instructions with the data in specified registers.

| PID control [PID]   |  |                     |  |
|---------------------|--|---------------------|--|
| 16 bits instruction | PID  | 32 bits instruction | -                                      |
| Executing Condition | Normally ON/normally closed coil activates | Suitable Models     | XC2, XC3, XC5, XCM, XCC                |
| Hardware Condition  | V3.0 or above                              | Software Condition  | V3.0 or above                          |
|                     | V3.3a and above (critical oscillation)     |                     | V3.3f and above (critical oscillation) |

### 2、Operands

| Operands | Usage   | Type              |
|----------|---|-------------------|
| S1       | set the address of the target value (SV)                | 16bits, BIN       |
| S2       | set the address of the tested value (PV)                | 16 bits, BIN      |
| S3       | set the start address of the control parameters         | 16 bits, BIN      |
| D        | the address of the operation result (MV) or output port | 16 bits, BIN; bit |

3、 Suitable soft components

| Word Type | Operands | System |    |    |    |    |    |    |    | Constant | Module |    |    |
|-----------|----------|--------|----|----|----|----|----|----|----|----------|--------|----|----|
|           |          | D      | HD | ED | TD | CD | DX | DY | DM | DS       | K/H    | ID | QD |
| S1        | •        |        |    |    |    |    |    |    |    |          | •      |    |    |
| S2        | •        |        |    |    |    |    |    |    |    |          |        | •  |    |
| S3        | •        |        |    |    |    |    |    |    |    |          |        |    |    |
| D         | •        |        |    |    |    |    |    |    |    |          |        |    | •  |

  

| Bit Type | Operands | System |   |   |   |   |   |     |
|----------|----------|--------|---|---|---|---|---|-----|
|          |          | X      | Y | M | S | T | C | Dnm |
| D        |          | •      | • | • | • | • |   |     |

**Functions and Actions**

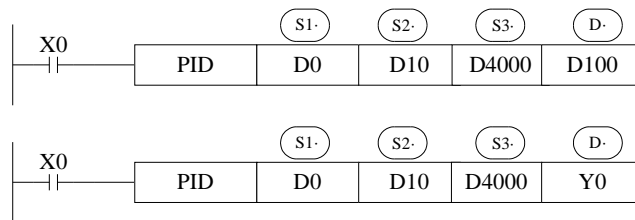

- S3~ S3+ 43 will be occupied by this instruction, so please don't use them as the common data registers.
- This instruction executes when each sampling time interval comes.
- To the operation result **D**, the data registers are used to store PID output values; the output points are used to output the occupy space ratio in the form of ON/OFF.
- PID control rules are shown as below:

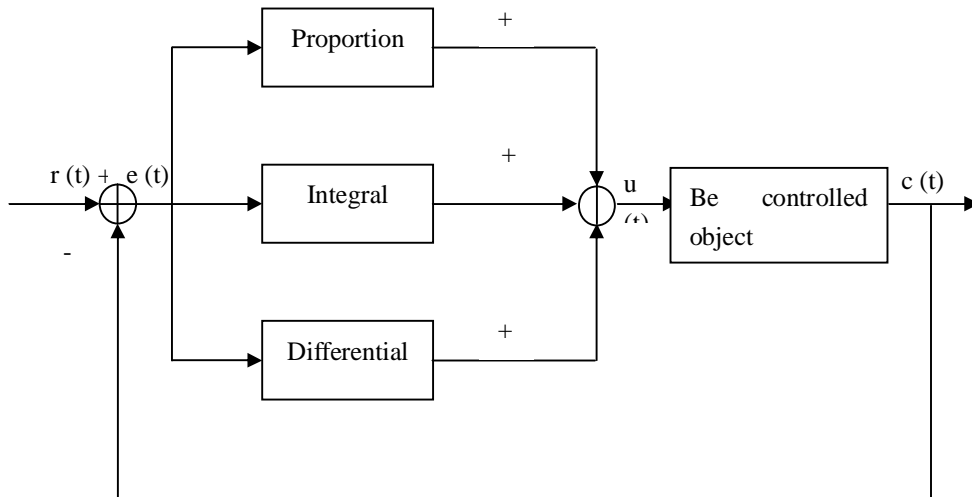

$$e(t) = r(t) - c(t) \tag{1-1}$$

$$u(t) = K_p [ e(t) + 1/T_i \int e(t) dt + T_D de(t)/dt ] \tag{1-2}$$

Here,  $e(t)$  is error,  $r(t)$  is the given value,  $c(t)$  is the actual output value, and  $u(t)$  is the control value;

In function (1-2),  $K_p$  is the proportion coefficient,  $T_i$  is the integration time coefficient, and  $T_D$  is the differential time coefficient.

The result of the operation:

- Analog output:  $MV = \text{digital form of } u(t)$ , the default range is 0 ~ 4095.
- Digital output:  $Y = T * [MV / \text{PID output upper limit}]$ .  $Y$  is the outputs activate time within the control cycle.  $T$  is the control cycle, equals to the sampling time. PID output upper limit default value is 4095.

### 8-3. Parameters Setting

Users can call PID instruction in XCP Pro software directly and set the parameters in the window (see graph below), for the details please refer to XCPPro user manual. Users can also write the parameters into the specified registers by MOV instructions before PID operation.

PID Instruction Parameter Config

Target Value (SV): D0    Measure Value(PV): D10    Parameter: D4000    Output: Y0

**Parameter Config**

Manual     Auto

Sampling Time: 0 ms

Proportion Gain (KP): 0 %

Integration Time(TI): 0 \*100ms

Differential Time(TD): 0 \*10ms

PID Computation Scope: 0

PID Control Death Band: 0

Self Study Periodic Value: 0

**Mode Config**

Common Mode     Advanced Mode

Input Filter Constant (a): 0 %

Differential Increase (KD): 50 %

Output Upper Limit Value: 4095

Output Lower Limit Value: 0

**Direction Config**

Negative Movement     Positive Movement

Negative Movement: Along with the increase of the measures definite value PV, outputvalue MV will also reduce.  
It's usually used in heat up control.

Positive Movement: Along with the increase of the measures definite value PV, outputvalue MV will also increase.  
It's usually used in cool control.

**Overshoot Config**

Enable Overshoot     Disable Overshoot

Each time adjust the increase: 100 %

Current target value resident Count: 15

Suggestion value

Hold Mem Register: Can't Read  
Parameter Range: D4000 - D4043

Read From PLC    Write To PLC    OK    Cancel

Auto tune mode:

V3.3f and higher version software can choose auto tune mode: step response or critical oscillation.

### 8-3-1. Registers and their functions

For PID control instruction's relative parameters ID, please refer to the below table:

| ID   | Function      | Description  | Memo     |
|------|---------------|--|----------|
| S3   | sampling time | 32 bits without sign   | Unit: ms |
| S3+1 | sampling time | 32 bits without sign   | Unit: ms |
| S3+2 | mode setting  | bit0:<br>0: Negative action; 1 positive action;<br>bit1~bit6 not usable<br>bit7:<br>0: Manual PID; 1: auto tune PID<br>bit8:<br>1: auto tune successful flag |          |

|   |   |  |   |
|---|---|--|---|
|   |   | bit9~bit10 auto tune method<br>00: step response<br>01: critical oscillation<br>Bit11~bit12: not use<br>Bit13~bit14: auto tune PID mode(valid in critical oscillation mode)<br>00: PID control<br>01: PI control<br>10: P control<br>bit15:<br>0: regular mode; 1: advanced mode |   |
| S3+3  | Proportion Gain (Kp)  | Range: 1~32767[%]  |   |
| S3+4  | Integration time (TI)   | 0~32767[*100ms]  | 0 is taken as no integral.              |
| S3+5  | Differential time (TD)  | 0~32767[*10ms]   | 0 is taken as no differential.          |
| S3+6  | PID operation zone  | 0~32767  | PID adjustment band width value.        |
| S3+7  | control death zone  | 0~32767  | PID value keeps constant in death zone  |
| S3+8  | PID auto tune cycle varied value  | full scale AD value * (0.3~1%)   |   |
| S3+9  | PID auto tune overshoot permission  | 0: enable overshoot<br>1: not overshoot  | (valid when using step response method) |
| S3+10   | current target value adjustment percent in auto tune finishing transition stage |  |   |
| S3+11   | current target value resident count in auto tune finishing transition stage     |  |   |
| S3+12~<br>S3+39                                     | occupied by PID operation's internal process                                    |  |   |
| <b>Below is the ID of advanced PID mode setting</b> |   |  |   |
| S3+40   | Input filter constant (a)   | 0~99[%]  | 0: no input filter                      |
| S3+41   | Differential gain (KD)  | 0~100[%]   | 0: no differential gain                 |
| S3+42   | Output upper limit value  | -32767~32767   |   |
| S3+43   | Output lower limit value  | -32767~32767   |   |

### 8-3-2. Parameters Description

- **Movement Direction:**

- Positive movement: the output value MV will increase with the increasing of the detected value PV, usually used for cooling control.
- Negative movement: the output value MV will decrease with the increasing of the detected value PV, usually used for heating control.

- **Mode Setting**

- Common Mode:

The parameter's register zone is from **S3** to **S3+43**, **S3** to **S3+11** needs to be set by users. **S3+12** to **S3+43+12** are occupied by the system, users can't use them.

- Advanced Mode

The parameter's register zone is from **S3** to **S3+43**, **S3** to (**S3+11**) and (**S3+40**) to (**S3+43**) need to be set by users. (**S3+12**) to (**S3+39**) are occupied by the system, users can't use them.

- **Sample Time [S3]**

The system collected the current value according to the certain time interval and compared them with the output value. This time interval is the sample time **T**. There is no requirement for **T** during **AD** output. **T** should be larger than one PLC scan period during port output. **T** value should be chosen among 100~1000 times of PLC scan periods.

- **PID Operation Zone [S3+6]**

PID control is entirely opened at the beginning and close to the target value with the highest speed (the defaulted value is 4095), when it entered into the PID computation range, parameters **Kp**, **Ti**, **TD** will be effective.

See graph below:

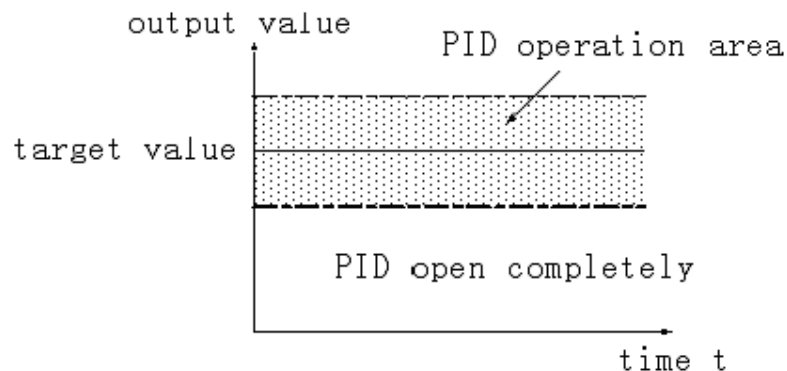

If the target value is 100, PID operation zone is 10, and then the real PID's operation zone is from 90 to 110.

- **Death Region [S3+7]**

If the detected value changed slightly for a long time, and PID control is still in working mode, then it belongs to meaningless control. Via setting the control death region, we can overcome this condition. See graph below:

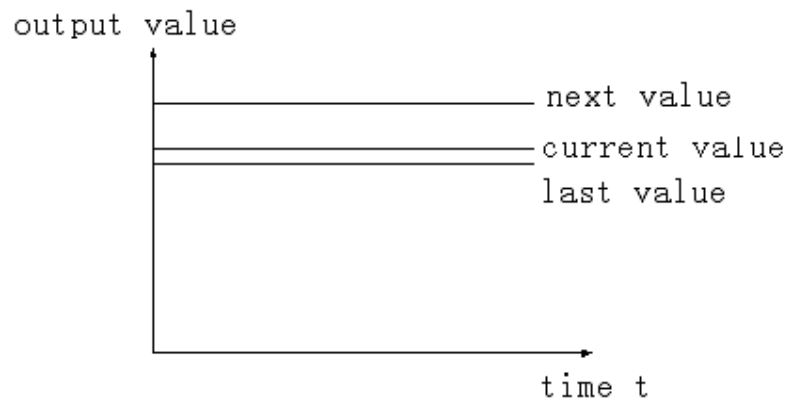

Suppose: we set the death region value to be 10. Then in the above graph, the difference is only 2 comparing the current value with the last value. It will not do PID control. The difference is 13 (more than death region 10) comparing the current value with the next value, this difference value is larger than control death region value; it will do the PID control with 135.

#### 8-4. Auto Tune Mode

If users do not know how to set the PID parameters, they can choose auto tune mode which can find the best control parameters (sampling time, proportion gain  $K_p$ , integral time  $T_i$ , differential time  $T_D$ ) automatically.

- Auto tune mode is suitable for these objects: temperature, pressure; not suitable for liquid level and flow.
- For step response method: Users can set the sampling cycle to be 0 at the beginning of the auto tune process then modify the value manually in terms of practical needs after the auto tune process is completed.
- For step response method: Before doing auto tune, the system should be under the non-control steady state. Take the temperature for example; the detected temperature should be the same to the environment temperature.
- For critical oscillation method: user needs to set the sampling time at the beginning of the auto tune process. Reference value: for slow response system, 1000ms. For high response system, 10-100ms.
- For critical oscillation method: the system can start the auto tune at any state. For temperature object, the current temperature doesn't need to be same to ambient temperature.
- Two different method and PID control diagram:
  - (1) Step response method
    - Make sure current temperature is equal to ambient temperature

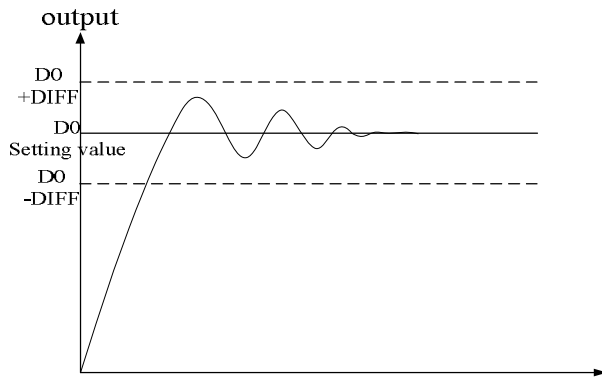

## (2) Critical oscillation method

The auto tune start temperature can be any value

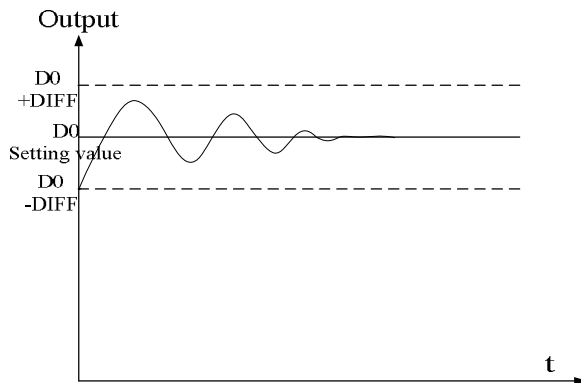

To enter the auto tune mode, please set bit7 of (**S3+ 2**) to be 1 and turn on PID working condition.

If bit8 of (**S3+ 2**) turn to 1, it means the auto tune is successful.

- PID auto tune period value [**S3+ 8**]

Set this value in [**S3+ 8**] during auto tune.

This value decides the auto tune performance, in a general way, set this value to be the AD result corresponding to one standard detected unit. The default value is 10. The suggested setting range:

**full-scale AD result × 0.3 ~ 1%.**

User doesn't need to change this value. However, if the system is interfered greatly by outside, this value should be increased modestly to avoid wrong judgment for positive or negative movement. If this value is too large, the PID control period (sampling time) got from the auto tune process will be too long. As the result do not set this value too large.

---

※1: if users have no experience, please use the defaulted value 10, set PID sampling time (control period) to be 0ms then start the auto tune.

---

- PID auto tune overshooting permission setting [**S3+ 9**]

If set 0, overshooting is permitted, the system can study the optimal PID parameters all the time.

But in auto tune process, detected value may be lower or higher than the target value, safety factor should be considered here.

If set 1, overshooting is not permitted. For these objectives which have strict safety demand such as pressure vessel, set [S3+ 9] to be 1 to prevent from detected value seriously over the target value. In this process, if [S3+ 2] bit8 changes from 0 to 1, it means the auto tune is successful and the optimal parameters are got; if [S3+ 2] is always 0 until [S3+ 2] bit7 changes from 1 to 0, it means the auto tune is completed but the parameters are not the best and need to be modified by users.

- Every adjustment percent of current target value at auto tune process finishing transition stage [S3+10]

This parameter is effective only when [S3+ 9] is 1.

If doing PID control after auto tune, small range of overshooting may be occurred. It is better to decrease this parameter to control the overshooting. But response delay may occur if this value is too small. The defaulted value is 100% which means the parameter is not effective. The recommended range is 50~80%.

Cutline Explanation:

Current target value adjustment percent is 2/3 ( $S3 + 10 = 67\%$ ), the original temperature of the system is 0 °C, target temperature is 100 °C, and the current target temperature adjustment situation is shown as below:

Next current target value = current target value + (final target value – current target value) × 2/3;

So the changing sequence of current target is 66 °C, 88 °C, 96 °C, 98 °C, 99 °C, 100 °C.

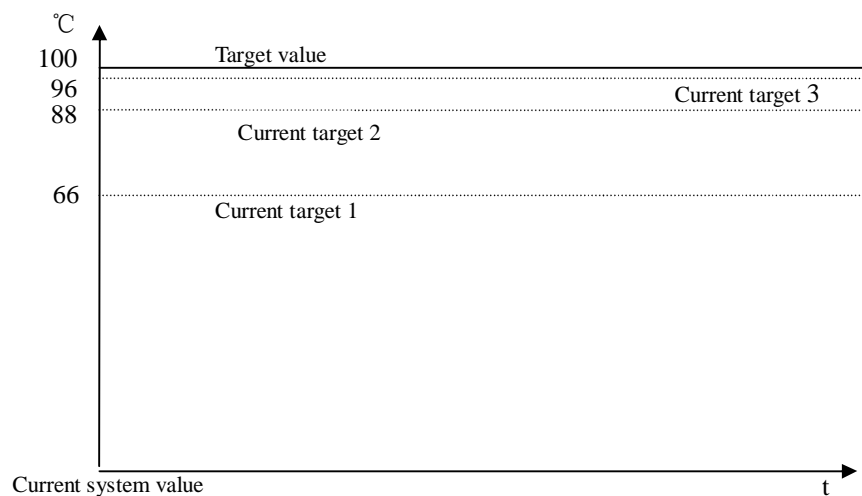

- The stay times of the current target value in auto tune process finishing transition stage [S3+11]

This parameter is valid only when [S3+9] is 1;

If entering into PID control directly after auto tune, small range of overshoot may occur. It is good for preventing the overshoot if increasing this parameter properly. But it will cause response lag if this value is too large. The default value is 15 times. The recommended range is from 5 to 20.

### 8-5. Advanced Mode

Users can set some parameters in advanced mode in order to get the better effect of PID control. Enter into the advanced mode, please set [S3+2] bit 15 to be 1, or set it in the XCP Pro software.

- Input Filter constant

It will smooth the sampling value. The default value is 0% which means no filter.

- Differential Gain

The low pass filtering process will relax the sharp change of the output value. The default value is 50%; the relaxing effect will be more obviously if increasing this value. Users do not need to change it.

- Upper-limit and lower-limit value

Users can choose the analog output range via setting this value.

Default value: lower- limit output= 0

Upper -limit= 4095

### 8-6. Application Outlines

- Under the circumstances of continuous output, the system whose effect ability will die down with the change of the feedback value can do self-study, such as temperature or pressure. It is not suitable for flux or liquid level.
- Under the condition of overshoot permission, the system will get the optimal PID parameters from self-study.
- Under the condition of overshoot not allowed, the PID parameters got from self-study is up to the target value, it means that different target value will produce different PID parameters which are not the optimal parameters of the system and for reference only.
- If the self-study is not available, users can set the PID parameters according to practical experience. Users need to modify the parameters when debugging. Below are some experience values of the control system for your reference:

- Temperature system:  
P (%) 2000 ~ 6000, I (minutes) 3 ~ 10, D (minutes) 0.5 ~ 3
- Flux system: P (%) 4000 ~ 10000, I (minutes) 0.1 ~ 1
- Pressure system: P (%) 3000 ~ 7000, I (minutes) 0.4 ~ 3
- Liquid level system: P (%) 2000 ~ 8000, I (minutes) 1 ~ 5

## 8-7. Application

PID Control Program is shown below:

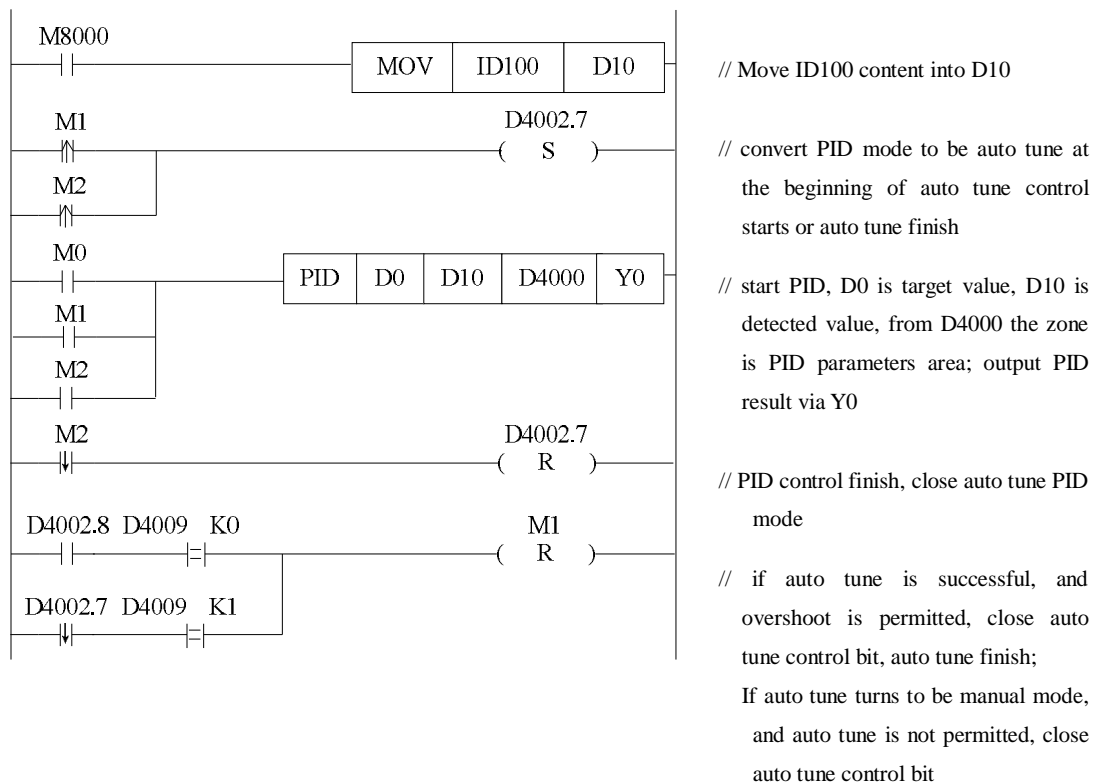

## 9 C Function Block

---

In this chapter, we focus on C language function block's specifications, edition, instruction calling, application points etc. we also attach the common Function list.

9-1. Functions Summary

9-2. Instrument Form

9-3. Operation Steps

9-4. Import and Export of the Functions

9-5. Edit the Function Block

9-6. Example Program

9-7. Application Points

9-8. Function List

## 9-1. Summary

This is the new added function in XCPPro software. This function enables the customers to write program via C language in XCPPo; and call the C program at any necessary place. This function supports most of C language functions, strength the program's security. As users can call the function at many places and call different functions, this function increase the programmer's efficiency greatly.

## 9-2. Instruction Format

### 1、 Instruction Summary

Call the C language Func Block at the specified place

| Call the C language Func Block [NAME_C] |  |                         |                                 |
|---|--|-------------------------|---------------------------------|
| 16 bits<br>Instruction                  | NAME_C   | 32 bits<br>Instruction  | -                               |
| Execution<br>Condition                  | Normally ON/OFF,<br>Rising/Falling Edge activation | Suitable<br>Models      | XC1, XC2, XC3, XC5, XCM,<br>XCC |
| Hardware<br>Requirement                 | V3.0C and above                                    | Software<br>Requirement | V3.0C and above                 |

### 2、 Operands

| Operands | Function   | Type         |
|----------|--|--------------|
| S1       | name of C Func Block, defined by the user                            | String       |
| S2       | Correspond with the start ID of word <b>W</b> in C language Function | 16 bits, BIN |
| S3       | Correspond with the start ID of word <b>B</b> in C language Function | 16 bits, BIN |

### 3、 Suitable Soft Components

|      |          |        |    |    |    |    |    |     |    |          |        |    |
|------|----------|--------|----|----|----|----|----|-----|----|----------|--------|----|
| Word | Operands | System |    |    |    |    |    |     |    | Constant | Module |    |
|      |          | D      | FD | ED | TD | CD | DX | DY  | DM | DS       | K/H    | ID |
|      | S2       | •      |    |    |    |    |    |     |    |          |        |    |
| Bit  | Operands | System |    |    |    |    |    |     |    |          |        |    |
|      |          | X      | Y  | M  | S  | T  | C  | Dnm |    |          |        |    |
|      | S3       |        |    | •  |    |    |    |     |    |          |        |    |

## Functions and Actions

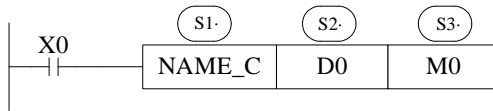

- The name is composed by numbers, letters and underlines, the first character can't be numbers, and the name's length shouldn't longer than 8 ASC.
- The name can't be same with PLC's self instructions like LD, ADD, SUB, PLSR etc.
- The name can't be same with the func blocks exist in current PLC;

### 9-3. Operation Steps

- 1、 Open PLC edit tool, in the left “Project” toolbar, choose “Func Block”, right click it and choose “Add New Func Block”

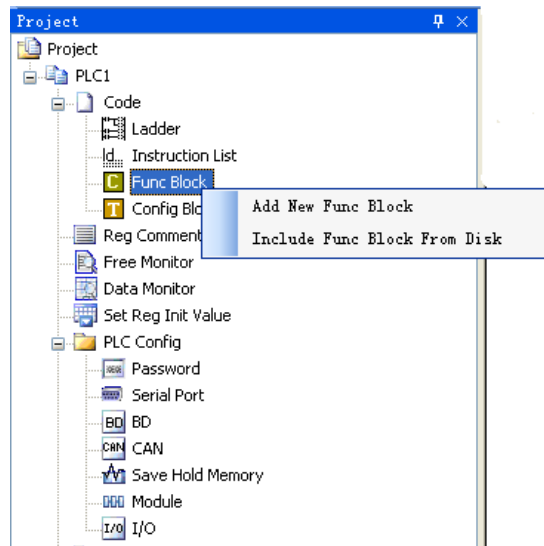

- 2、 See graph below, fill in the information of your function;

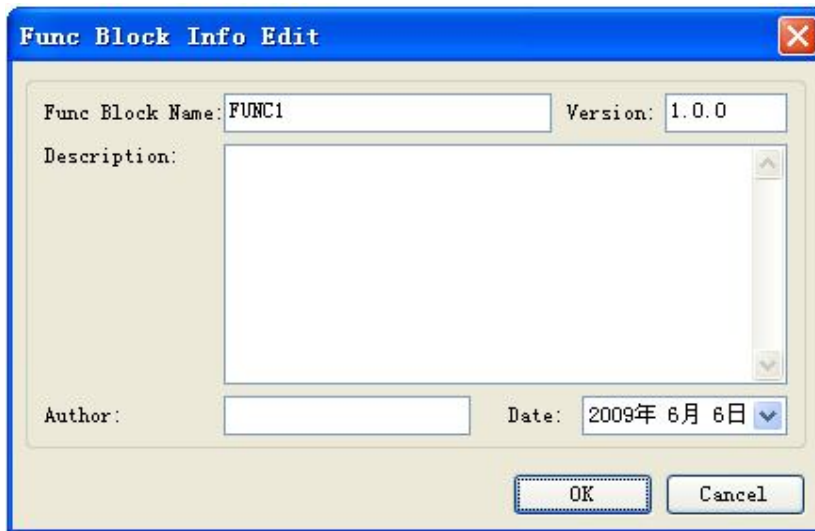

3、 After new create the Func Block, you can see the edit interface as shown below:

Main function's name (it's function block's name, this name can't be changed freely, and users should modify in the edit window.

```

1  /*****
2  FunctionBlockName:  FUNC1
3  Version:           1.0.0
4  Author:
5  UpdateTime:       2009-6-6 8:46:36
6  Comment:
7
8  *****/
9  void FUNC1( WORD W , BIT B )
10 {
11
12 }
13

```

Edit your C language program between “{}”

**WORD W:** correspond with soft component D  
**BIT B:** correspond with soft component M

- Parameters' transfer format: if call the **Func Block** in ladder, the transferred D and M is the start ID of W and B. Take the above graph as the example, start with D0 and M0, then W[0] is D0, W[10] is D10, B[0] is M0, B[10] is M10. If in the ladder the used parameters are D100, M100, then W[0] is D100, B [0] is M100. So, word and bit component's start address is defined in PLC program by the user.
- Parameter W: represent **Word** soft component, use in the form of data group. E.g. W [0] =1; W [1] =W [2] +W [3]; in the program, use according to standard C language rules.
- Parameter B: represent **Bit** soft component, use in the form of data group. Support **SET** and

- **RESET.** I.g: B[0]=1;B[1]=0; And assignment, for example B[0]=B[1].
- Double-word operation: add **D** in front of **W**, e.g. DW[10]=100000, it means assignment to the double-word W[10]W[11]
- Floating Operation: Support the definition of floating variable in the function, and execute floating operation;
- Function Library: In **Func Block**, users can use the Functions and Variables in function library directly. For the Functions and Variables in function library, see the list in Appendix.
- The other data type supported:

```

BOOL;           //BOOL Quantity
INT8U;          //8 bits unsigned integral
INT8S;          //8 bits signed integral
INT16U          //16 bits unsigned integral
INT16S          //8 bits signed integral
INT32U          //32 bits unsigned integral
INT32S          //32 bits signed integral
FP32;           //Single precision Floating
FP64;           // Double precision Floating

```

- Predefined Marco
 

|         |       |   |
|---------|-------|---|
| #define | true  | 1 |
| #define | false | 0 |
| #define | TRUE  | 1 |
| #define | FALSE | 0 |

## 9-4. Import and Export the Functions

### 1、Export

(1) Function: export the function as the file, then other PLC program can import to use;

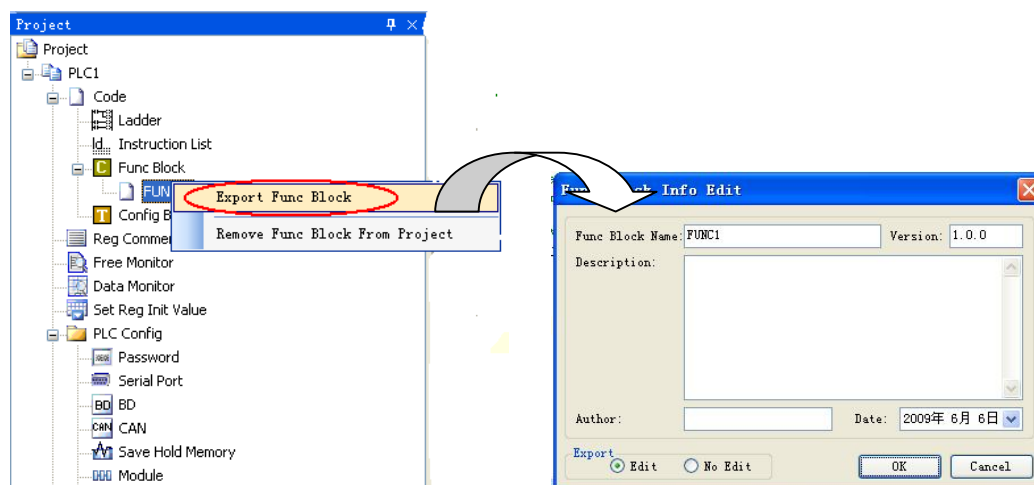

### (2) Export Format

- a) Editable; export the source codes out and save as a file. If import again, the file is editable;

b) Not editable: don't export the source code, if import the file, it's not editable;

## 2、 Import

Function; Import the exist **Func Block** file, to use in the PLC program;

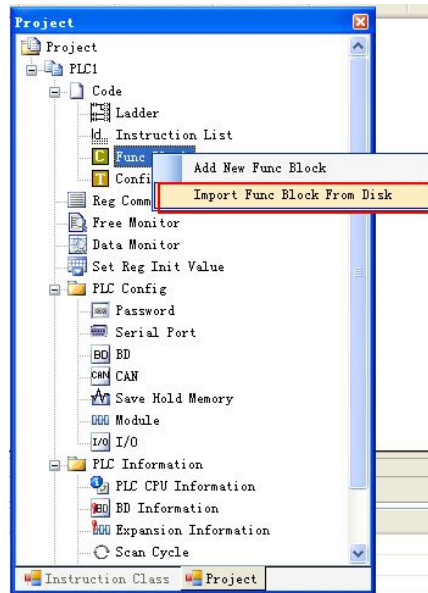

Choose the **Func Block**, right click “Import Func Block from Disk”, choose the correct file, and then click OK.

### 9-5. Edit the Func Blocks

Example: Add D0 and D1 in PLC's registers, and then assign the value to D2;

- (1) In “Project” toolbar, new create a **Func Block**, here we name the **Func Block** as **ADD\_2**, then edit C language program;
- (2) Click **compile** after edition

PLC1 - Ladder **FuncBlock-ADD\_1**

Information Export Compile

```

1 | /*****
2 |   FunctionBlockName:  ADD_1
3 |   Version:            1.0.0
4 |   Author:
5 |   UpdateTime:        2009-6-6 8:46:36
6 |   Comment:
7 |   W [ 2 ] = W [ 0 ] + W [ 1 ]
8 |   *****/
9 | void ADD_1 ( WORD W , BIT B )
10| {
11|   W[2]=W[0]+W[1]
12| }
13|

```

Information

Error List Output

```

1.
[Error(ccom):.../tmp/PrjFuncB/ADD_1.c,line 8] parse error at near ?
====> *****/
[Error(ccom):.../tmp/PrjFuncB/ADD_1.c,line 8] parse error at near ?
====> *****/
.../tmp/PrjFuncB/ADD_1.c

```

The information list

According to the information shown in the output blank, we can search and modify the grammar error in C language program. Here we can see that in the program there is no “;” sign behind `W [2] =W [0] +W [1];`

Compile the program again after modify the program. In the information list, we can confirm that there is no grammar error in the program;

```

PLC1 - Ladder FuncBlock-ADD_1
Information Export Compile
1 /*****
2   FunctionBlockName:  ADD_1
3   Version:           1.0.0
4   Author:
5   UpdateTime:       2009-6-6 10:31:47
6   Comment:
7   W[2]=W[1]+W[0]
8   *****/
9 void ADD_1( WORD W , BIT B )
10 {
11   W[2]=W[1]+W[0];
12 }
13
Information
Error List Output
1.
..\..\tmp\PrjFuncB\ADD_1.c
|

```

(3) Write PLC program, assign value 10 and 20 into registers D0, D1 separately, then call Func Block ADD\_2, see graph below:

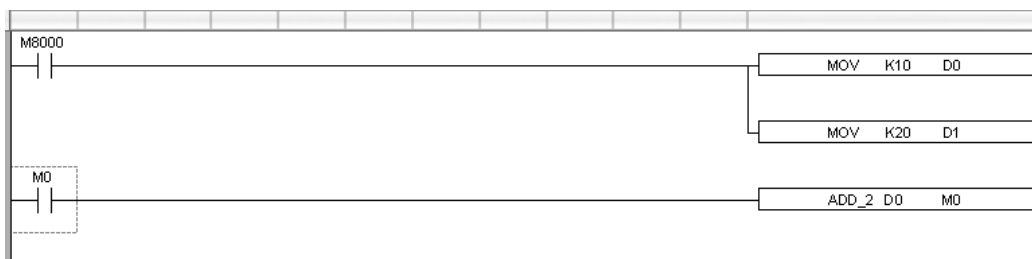

(4) Download program into PLC, run PLC and set M0.



(5) From Free Monitor in the toolbar, we can see that D2 changes to be 30, it means the assignment is successful;



## 9-6. Program Example

If PLC needs to do complicated calculation (including plus and minus calculation), the calculation will be used for many times, C language function is easy to use.

Example 1:

Calculation  $a=b/c+b*c+(c-3)*d$ .

Method 1: use ladder chart:

- Get the result of  $c-3$
- Get the result of three multiplication equations
- Get the sum

Ladder chart only support two original operands, it needs many steps to get the result.

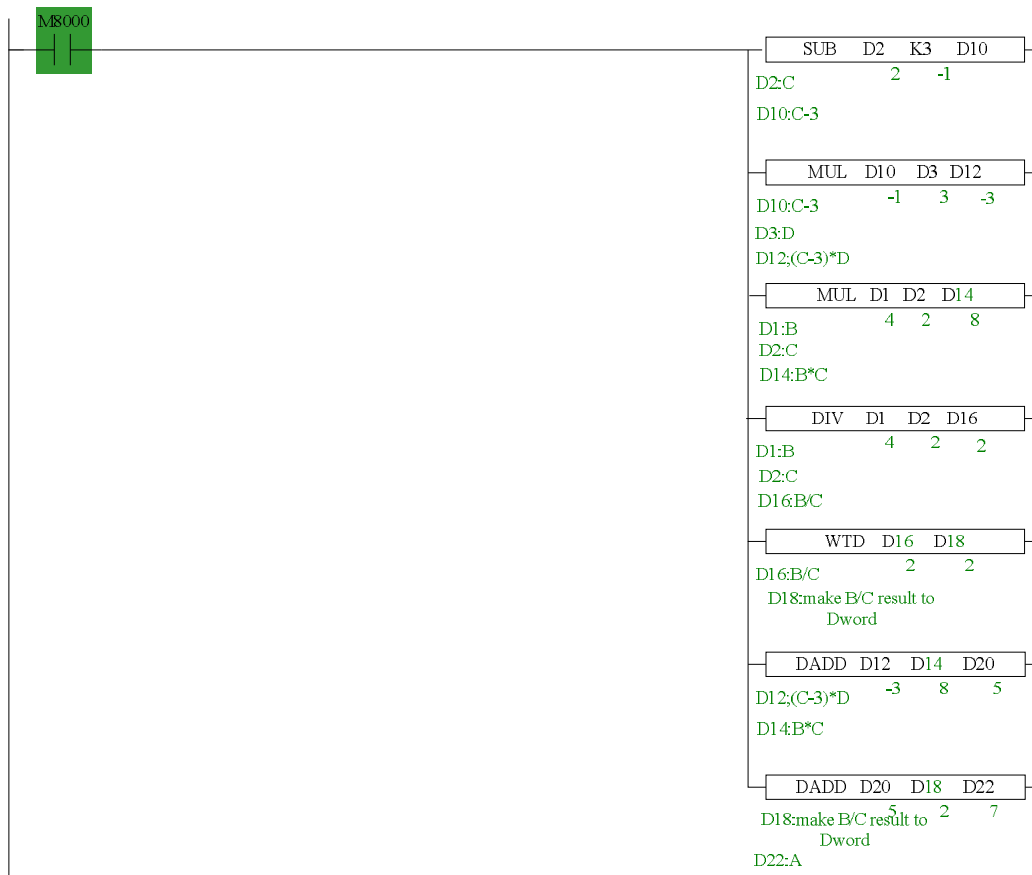

Note:

1. The result of MUL is Dword, the result is stored in D14~D15.
2. The result of DIV has quotient D16 and remainder D17. If D17 has value, the calculation precision will decrease. Please use float format to ensure the precision.
3. D16 quotient is word value, in plus calculation all the data should be changed to Dword. The final result is stored in D22~D23.

Method 2: use C language

Ladder chart:

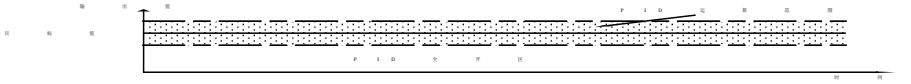

C program:

```

9  void RESULT( WORD W , BIT B )
10 {
11  long int a,b,c,d;;
12  b=W[1];
13  c=W[2];
14  d=W[3];
15  a=b/c+b*c+(c-3)*d;
16  DW[4]=a;
17 }

```

| RESULT | Function name  |
|--------|--|
| D0     | In the function, W [0] =D0, W [1] =D1....<br>If S2=D32, then W [0] =D32, W [1] =D33....  |
| M0     | In the function, B [0] =M0, B [1] =M1.....<br>If S2=M32, then B [0] =M32, B [1] =M33.... |

Method 2 can simplify the program.

The C function is the same to ladder chart of method 1. The precision is not high. If it needs to get the high precision, please use float calculation.

Example 2:

Calculate CRC parity value via Func Block

➤ CRC calculation rules:

(1) Set 16 bits register (CRC register) = FFFF H

- XOR (Exclusive OR) 8 bits information with the low byte of the 16 bits CRC register.
- Right shift 1 bit of CRC register, fill 0 in the highest bit.
- Check the right shifted value, if it is 0, save the new value from step3 into CRC register; if it is not 0, XOR the CRC register value with A001 H and save the result into the CRC register.
- Repeat step3&4 until all the 8 bits have been calculated.
- Repeat step2~5, then calculate the next 8 bits information. Until all the information has been calculated, the result will be the CRC parity code in CRC register.

- Edit C language Function Block program, see graph below:

```

9  void CRC_CHECK( WORD W , BIT B )
10 {
11     int i,j,m,n;
12     unsigned int reg_crc=0xffff,k;
13
14     for( i = 0 ; i < W[0] ; i++ )
15     {
16         reg_crc^=W[i+1];
17         for(j=0;j<8;j++)
18         {
19             if(reg_crc&0x01)
20                 reg_crc=(reg_crc>>1)^0xa001;
21             else
22                 reg_crc=reg_crc>>1;
23         }
24     }
25
26     m=W[0]+1;
27     n=W[0]+2;
28     k=reg_crc&0xff00;
29     W[m] = k>>8;
30     W[n]=reg_crc&0xff;
31 }

```

- Edit PLC ladder program,  
D0: Parity data byte number;  
D1~D5: Parity data's content, see graph below:

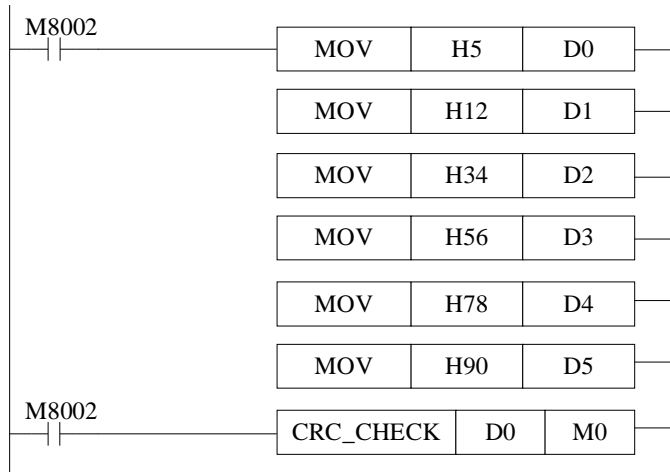

- Download to PLC, then RUN PLC, set M0, via Free Monitor, we can find that values in D6 and D7 are the highest and lowest bit of CRC parity value;

## 9-7. Application Points

- When upload the PLC program in which there are some Func Blocks, the Func Blocks can't be uploaded, there will be an error say: There is an unknown instruction;
- In one Func Block file, you can write many functions, they can be call each other;
- Each Func Block files is independent, they can't call each other;
- Func Block files can call C language library functions in form of floating, arithmetic like sin, cos, tan etc.
- XCPpro software v3.3 and later version add C function library:



In this function block, user can call the C function directly:

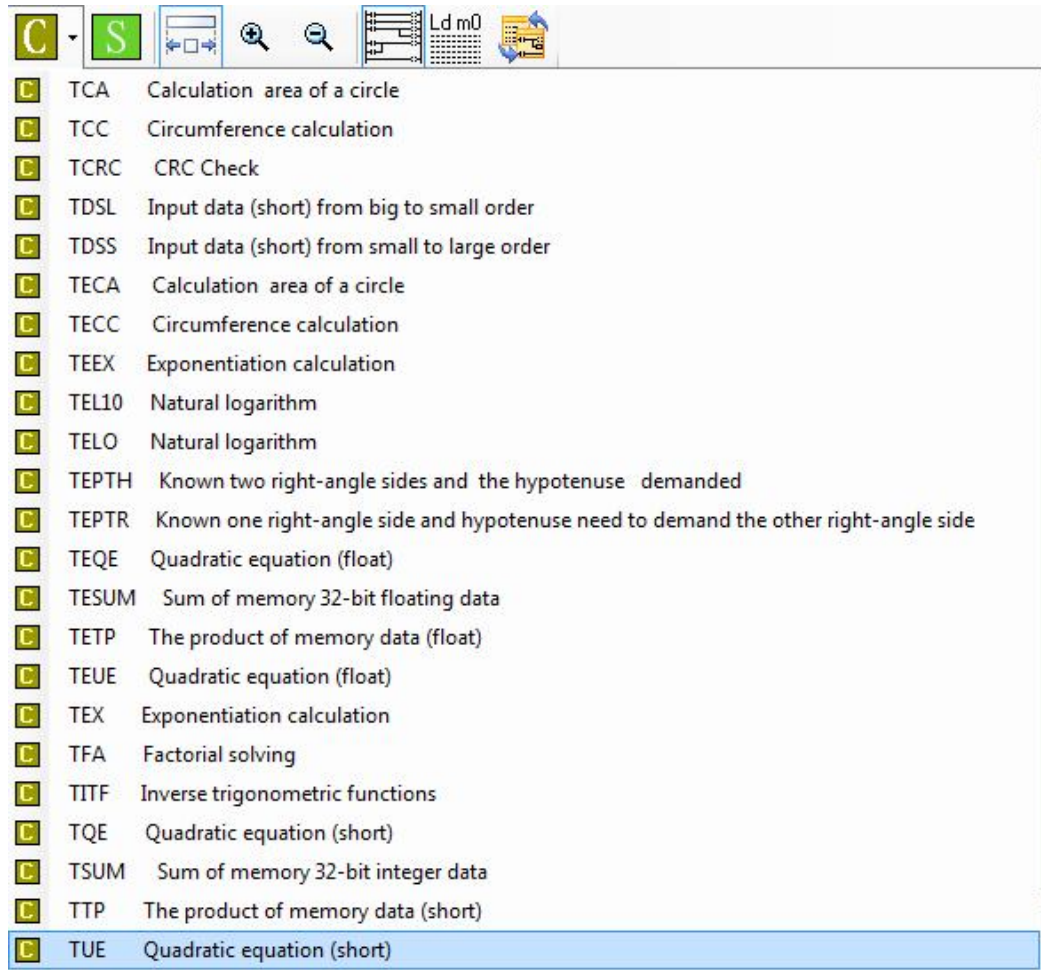

For example: click TEL10, the function name will show on the project bar:

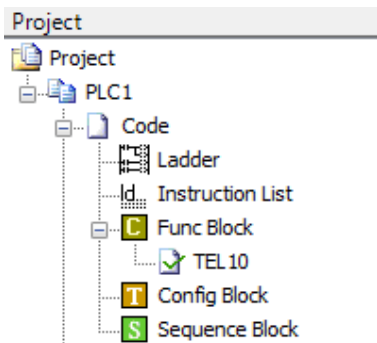

User can call it in the ladder chart editing window.

## 9-8. Function Table

The default function library

| Constant | Data                                       | Description     |
|----------|--|-----------------|
| _LOG2    | (double)0.693147180559945309417232121458   | Logarithm of 2  |
| _LOG10   | (double)2.3025850929940459010936137929093  | Logarithm of 10 |
| _SQRT2   | (double)1.41421356237309504880168872421    | Radical of 2    |
| _PI      | (double)3.1415926535897932384626433832795  | PI              |
| _PIP2    | (double)1.57079632679489661923132169163975 | PI/2            |
| _PIP2x3  | (double)4.71238898038468985769396507491925 | PI*3/2          |

| String Function                                       | Description   |
|---|---|
| void * memchr(const void *s, int c, size_t n);        | Return the first <b>c</b> position among <b>n</b> words before <b>s</b> position                          |
| int memcmp(const void *s1, const void *s2, size_t n); | Compare the first <b>n</b> words of position <b>s1</b> and <b>s2</b>                                      |
| void * memcpy(void *s1, const void *s2, size_t n);    | Copy <b>n</b> words from position <b>s2</b> to <b>s1</b> and return <b>s1</b>                             |
| void * memset(void *s, int c, size_t n);              | Replace the <b>n</b> words start from <b>s</b> position with word <b>c</b> , and return position <b>s</b> |
| char * strcat(char *s1, const char *s2);              | Connect string <b>ct</b> behind string <b>s</b>   |
| char * strchr(const char *s, int c);                  | Return the first word <b>c</b> position in string <b>s</b>  |
| int strcmp(const char *s1, const char *s2);           | Compare string <b>s1</b> and <b>s2</b>  |
| char * strcpy(char *s1, const char *s2);              | Copy string <b>s1</b> to string <b>s2</b>   |

| Double-precision math function    | Single-precision math function  | Description   |
|-----------------------------------|---------------------------------|---|
| double acos(double x);            | float acosf(float x);           | Inverse cosine function.  |
| double asin(double x);            | float asinf(float x);           | Inverse sine function   |
| double atan(double x);            | float atanf(float x);           | Inverse tangent function  |
| double atan2(double y, double x); | float atan2f(float y, float x); | Inverse tangent value of parameter (y/x)  |
| double ceil(double x);            | float ceilf(float x);           | Return the smallest double integral which is greater or equal with parameter <b>x</b> |
| double cos(double x);             | float cosf(float x);            | Cosine function   |
| double cosh(double x);            | float coshf(float x);           | Hyperbolic cosine function<br>$\cosh(x) = (e^x + e^{-x})/2$ .                         |
| double exp(double x);             | float expf(float x);            | Exponent ( $e^x$ ) of a nature data   |
| double fabs(double x);            | float fabsf(float x);           | Absolute value of parameter <b>x</b>  |

|   |  |  |
|---|--|--|
| double floor(double x);                   | float floorf(float x);                   | Return the largest double integral which is smaller or equals with <b>x</b>  |
| double fmod(double x, double y);          | float fmodf(float x, float y);           | If <b>y</b> is not zero, return the remainder of floating <b>x/y</b>   |
| double frexp(double val, int *_far *exp); | float frexpf(float val, int *_far *exp); | Break floating data <b>x</b> to be mantissa and exponent $x = m \cdot 2^{\text{exp}}$ , return the mantissa of <b>m</b> , save the logarithm into <b>exp</b> . |
| double ldexp(double x, int exp);          | float ldexpf(float x, int exp);          | <b>X</b> multiply the (two to the power of <b>n</b> ) is $x \cdot 2^n$ .   |
| double log(double x);                     | float logf(float x);                     | Nature logarithm $\log x$  |
| double log10(double x);                   | float log10f(float x);                   | logarithm ( $\log_{10} x$ )  |
| double modf(double val, double *pd);      | float modff(float val, float *pd);       | Break floating data <b>X</b> to be integral part and decimal part, return the decimal part, save the integral part into parameter <b>ip</b> .                  |
| double pow(double x, double y);           | float powf(float x, float y);            | Power value of parameter <b>y</b> ( $x^y$ )  |
| double sin(double x);                     | float sinf(float x);                     | sine function  |
| double sinh(double x);                    | float sinhf(float x);                    | Hyperbolic sine function, $\sinh(x) = (e^x - e^{-x})/2$ .  |
| double sqrt(double x);                    | float sqrtf(float x);                    | Square root of parameter <b>X</b>  |
| double tan(double x);                     | float tanf(float x);                     | tangent function.  |
| double tanh(double x);                    | float tanhf(float x);                    | Hyperbolic tangent function, $\tanh(x) = (e^x - e^{-x}) / (e^x + e^{-x})$ .  |

The using method of the functions in the table:

Take function arcsin as an example.

float asinf (float x);

float asinf: float means the return value is float format;

float x: float means the function formal parameter is float format.

In actual using, it no needs to write the float. See line14 in the following example:

```

9 void ZHENGXIAN( WORD W , BIT B )
10 {
11 int a;
12 float x, y, z;
13 x=FW[0];
14 y=asinf(x);
15 z=180*y/3.14159;
16 a=(int) z;
17 W[2]=a;
18 }

```

# 10 Sequence block

---

This chapter will introduce the sequence block instruction and the application.

10-1. Concept of the BLOCK

10-2. Call the BLOCK

10-3. Edit the instruction inside the BLOCK

10-4. Running form of the BLOCK



10-5. BLOCK instruction editing rules

10-6. BLOCK related instructions

10-7. BLOCK flag bit and register

10-8. Program example

Block instruction:

| Instruction | Function                   | Ladder chart   | Chapter |
|-------------|----------------------------|--|---------|
| Block       |                            |  |         |
| SBSTOP      | Stop the BLOCK             |  | 10-6-1  |
| SBGOON      | Continue running the BLOCK |  | 10-6-1  |

## 10-1. Concept of the BLOCK

### 10-1-1. BLOCK summarization

Sequence block, which is also called block, is a program block can realize certain function. Block is a special flow, all the instructions run in order; this is the difference from other flows. BLOCK starts from SBLOCK and ends by SBLOCKE, you can write program between them. If there are many pulse output instructions (or other instructions), they will run one after one according to the condition. After one pulse outputting over then the next pulse will output.

The construction of the block is as the following:

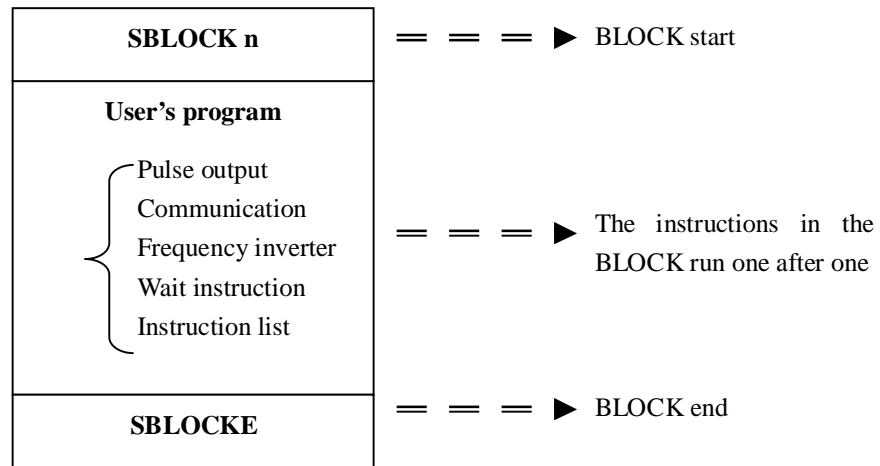

※1: The BLOCK quantity can up to 100 for XC series PLC, XC3-14 BLOCK quantity is 30.

**10-1-2. The reason to use BLOCK**

To optimize the editing method of pulse and communication instruction in the process  
 In former program, XC series PLC can not support many pulse or communication instructions in one process, but BLOCK can support this and the instructions will run in sequence.

|                   | Unavailable (×) | Available (√) |
|-------------------|-----------------|---------------|
| Former            |                 |               |
| After using block |                 |               |

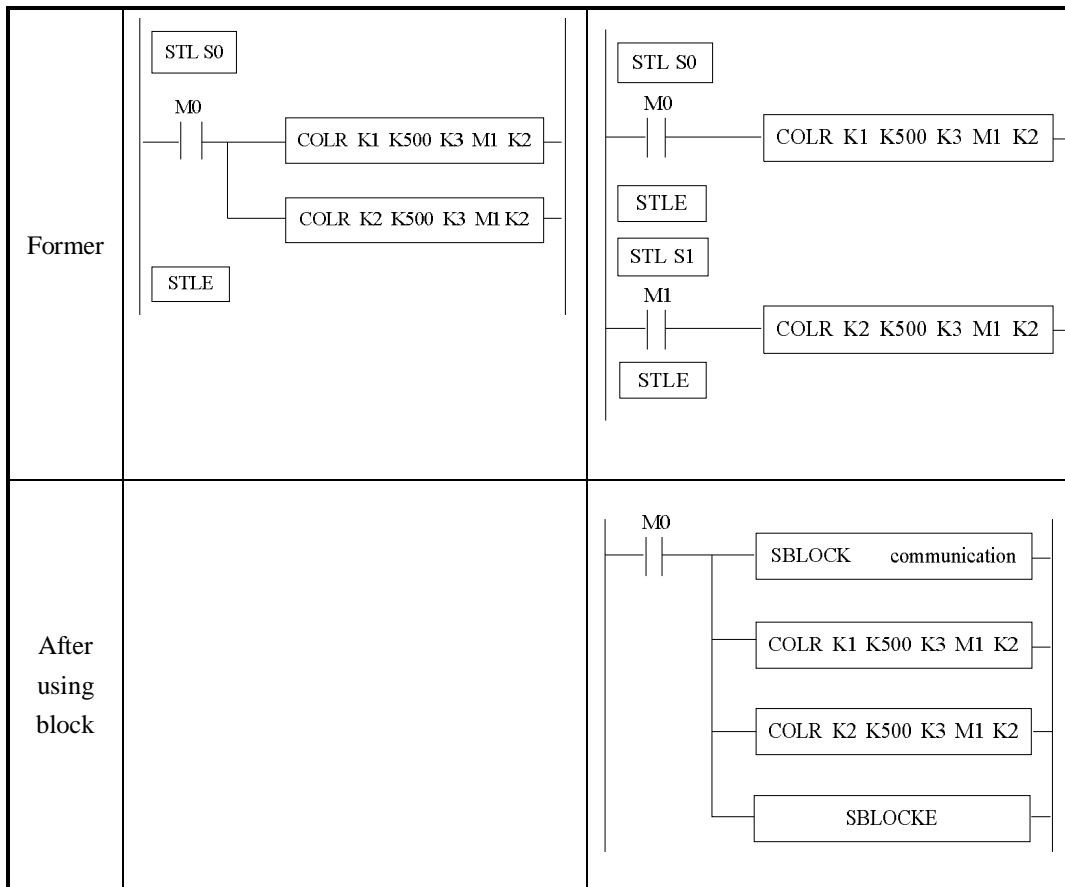

**Note:** when the trigger condition of BLOCK is normal ON coil, the BLOCK will execute one by one from up to down circular until the condition is OFF.

When the trigger condition of BLOCK is rising edge, the BLOCK will execute once from up to down.

## 10-2. Call the BLOCK

In one program file, it can call many BLOCK; the following is the method to add BLOCK in the program.

### 10-2-1. Add the BLOCK

Open XCPpro software; right click the sequence block in the project bar:

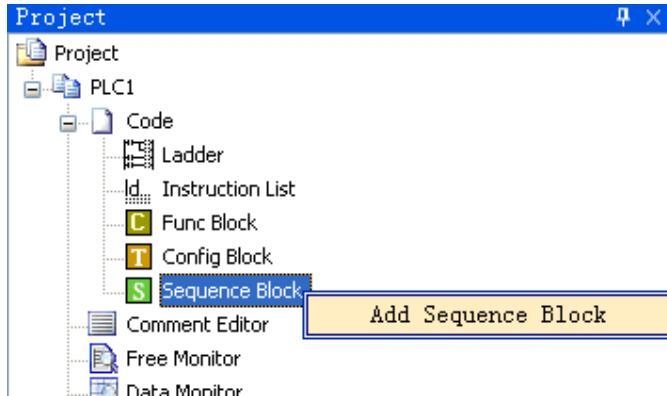

Click “add sequence block” will show below window:

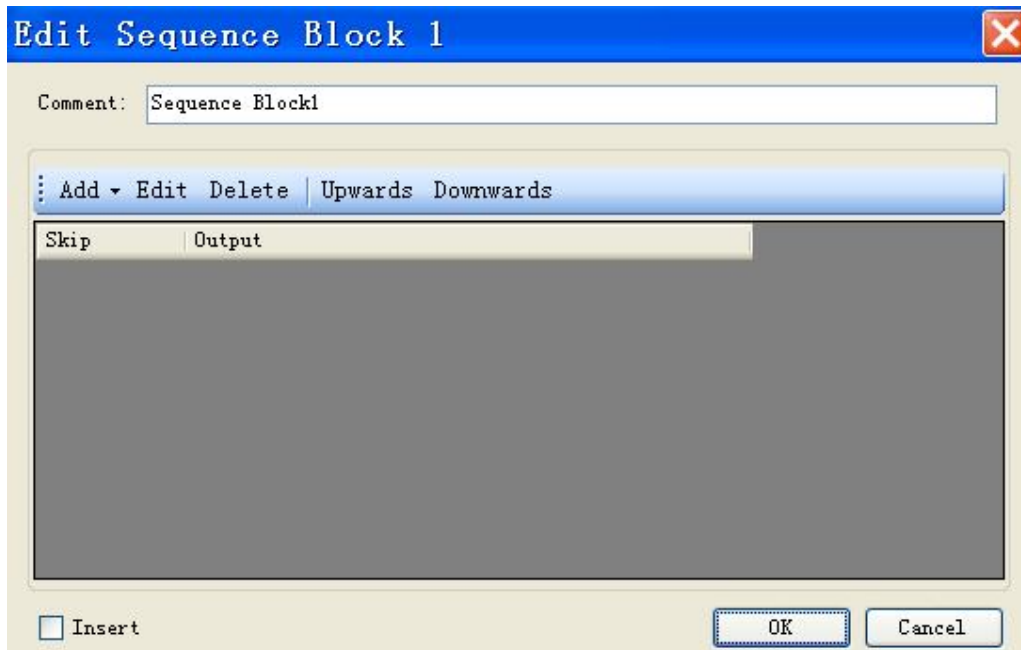

You can edit the program in this window. Upwards and downwards are used to change the position of the instruction in the block.

There is an “Insert” choice on the bottom left of the window, when selecting it, the add button will become insert:

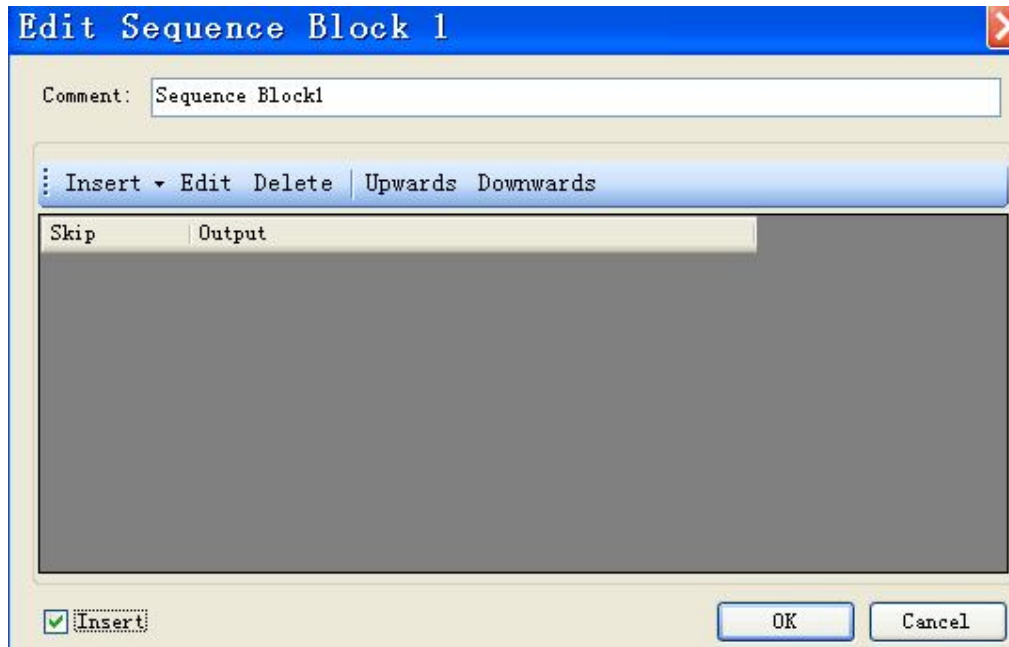

The difference between insert and add:

Add is to add instructions in the end of the block; insert can add instruction in any place in the block.

Click add button, you will see the instructions can be added in the block.

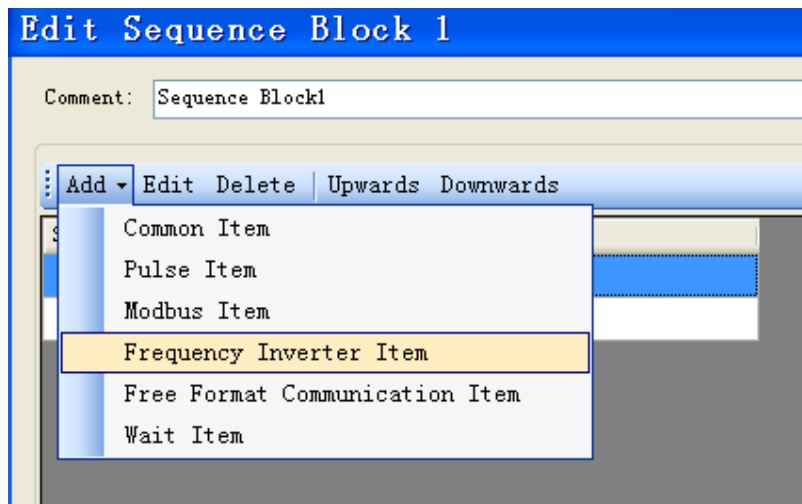

For example, add a pulse item in the program:

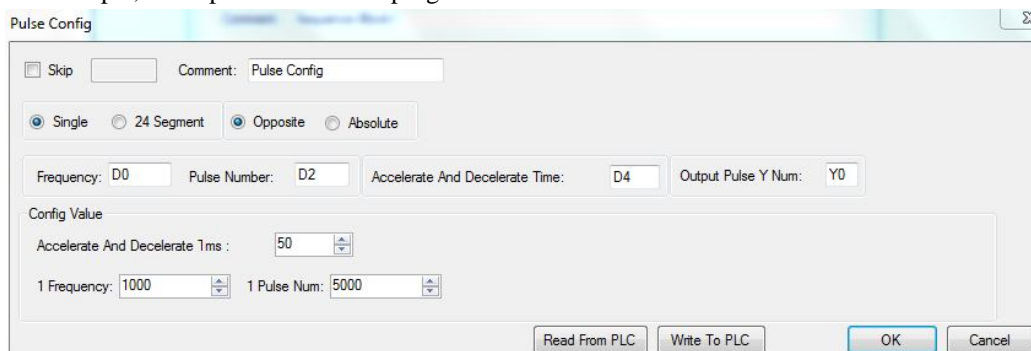

Click ok, the pulse item is added in the list:

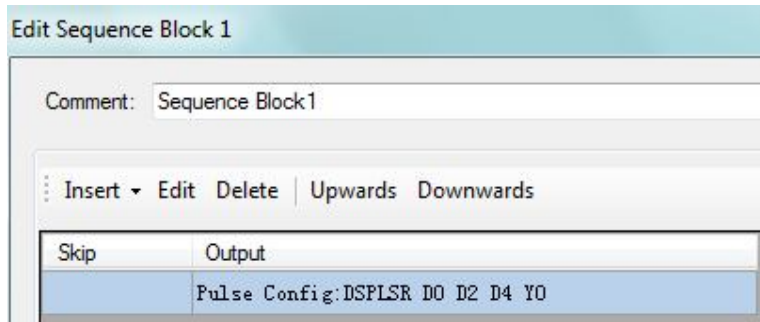

Click ok, the BLOCK will show in the program:

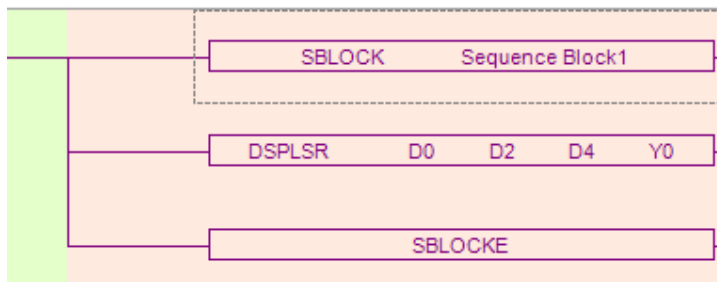

### 10-2-2. Move the BLOCK

If you want to move the block to other position, you have to select the former block and delete it.

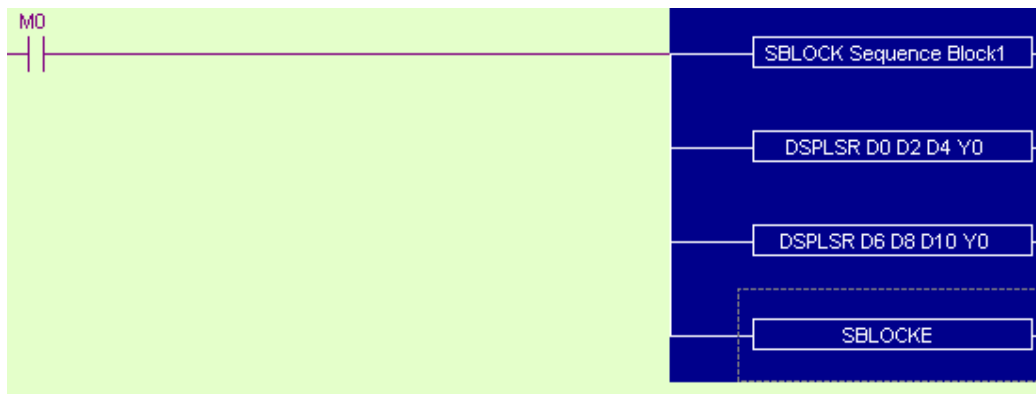

Then put the cursor in the place you want to move:

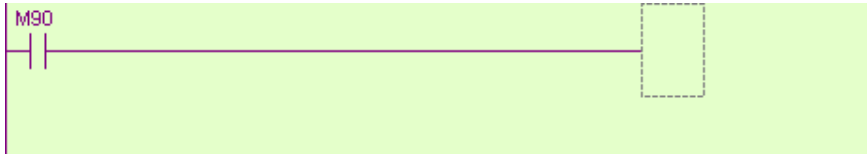

Right click the “add to lad” in the project bar:

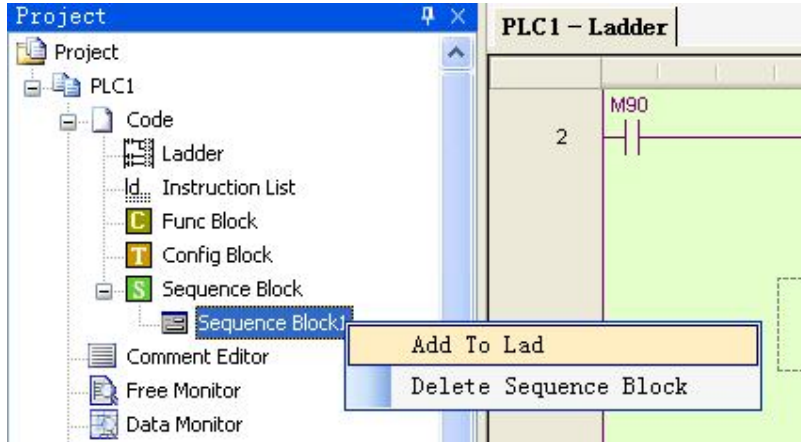

Now the block is moved to the new place:

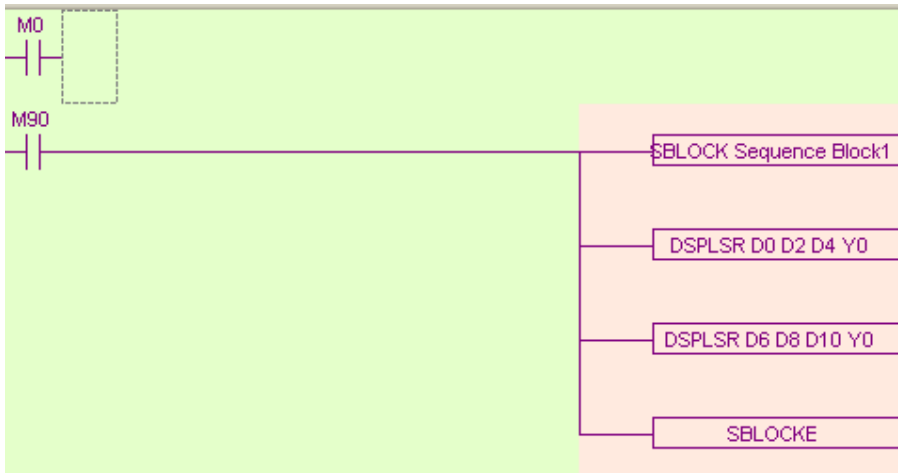

### 10-2-3. Delete the BLOCK

You can select the whole block and delete it. If you want to delete the block forever, please right click the block you want to delete in the project bar and select “delete sequence block”. After this operation, you can not call this block anymore.

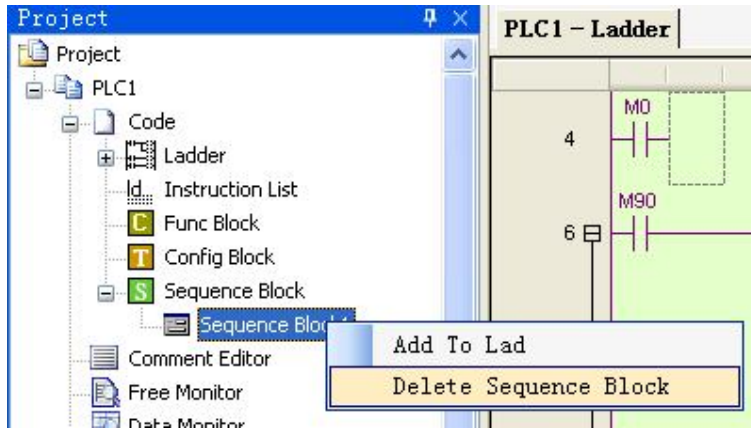

### 10-2-4. Modify the BLOCK

There are two methods to modify the block.

(A) double click the start or end instruction to modify all the instructions in the block.

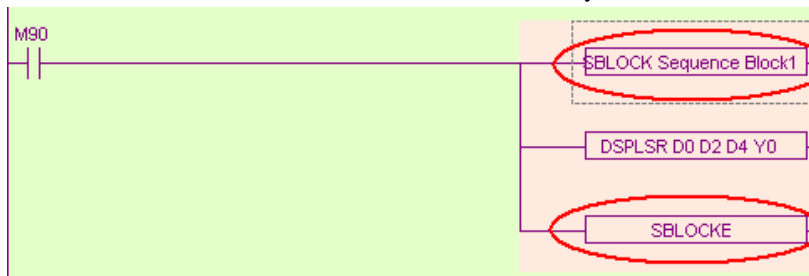

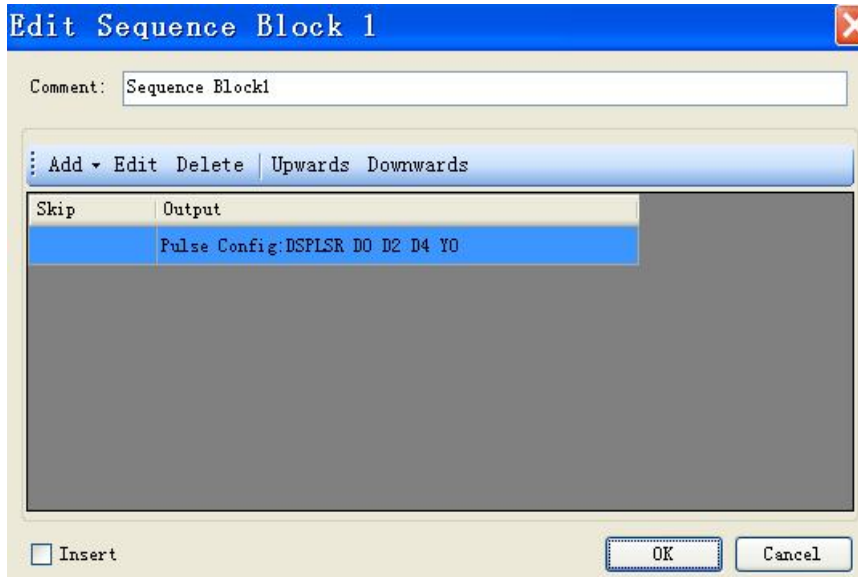

(B) double click one instruction in the block to modify it:

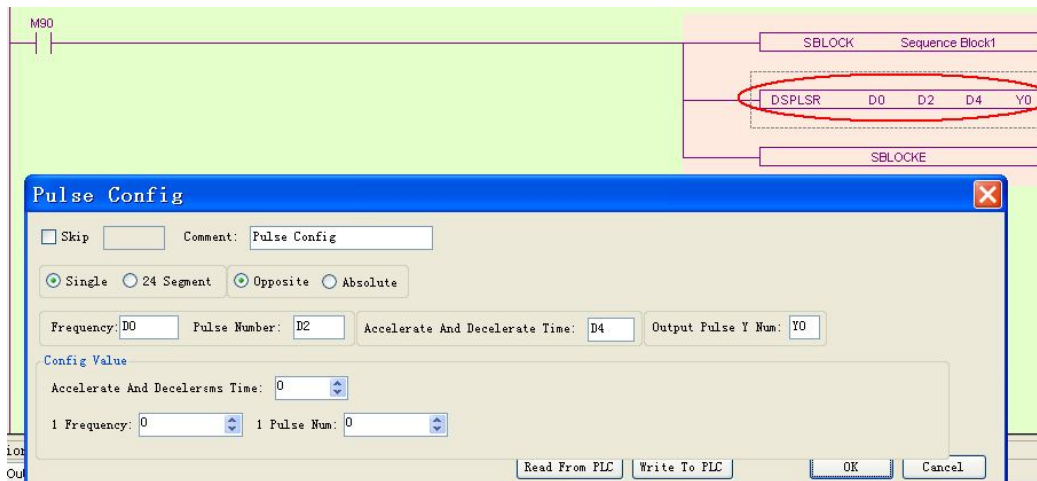

### 10-3. Edit the instruction inside the BLOCK

#### 10-3-1. Common item

Use command to edit the program.

Open the block editing window, click add/common item:

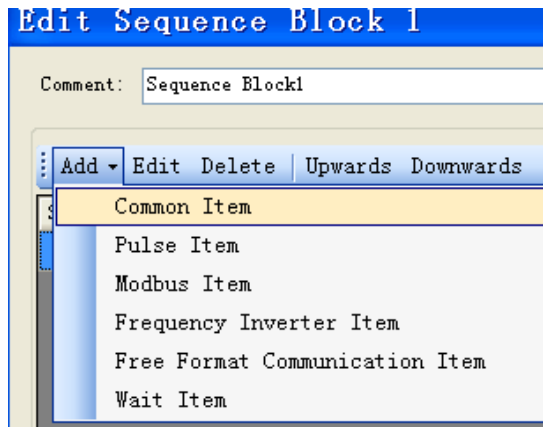

It will show the editing window:

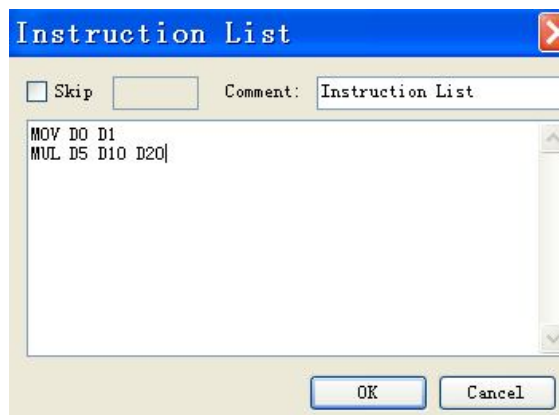

User can add instructions in this window.

SKIP condition: can control the stop and running of the instructions. When select skip and enter coil in it, if the coil is ON, the instructions will stop.

Comment: can modify the note for this instruction.



After setting, the block will be changed as the following:

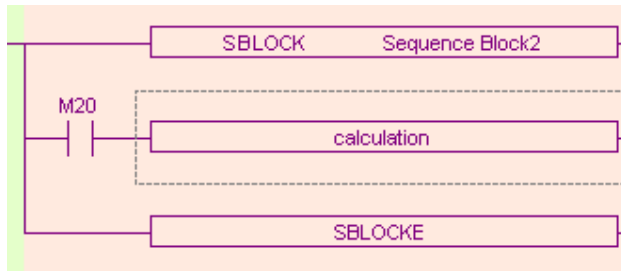

### 10-3-2. Pulse item

Open the pulse item window:

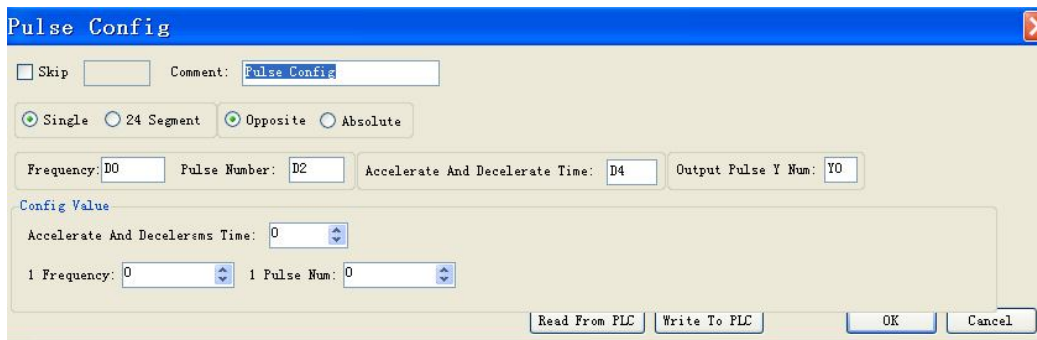

Set the pulse output frequency, numbers, output terminals, accelerate/decelerate time and so on. Then add the pulse instruction in the block:

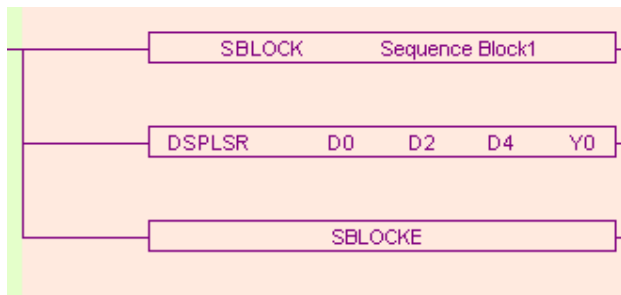

※1: The pulse output instructions are all 32bits.

### 10-3-3. Modbus item

Open the modbus item window:

Select the modbus instructions, set the address and com port, then software will build an instruction.

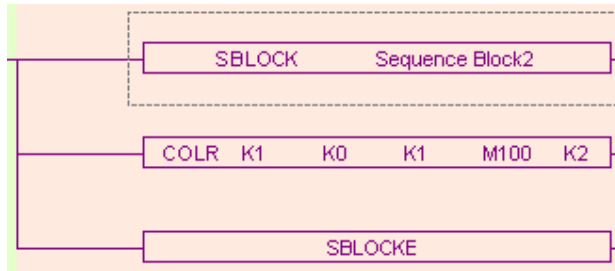

### 10-3-4. Wait item

There are two modes to wait.

(A) flag bit

(B) timer wait

The ladder chart is as the following:

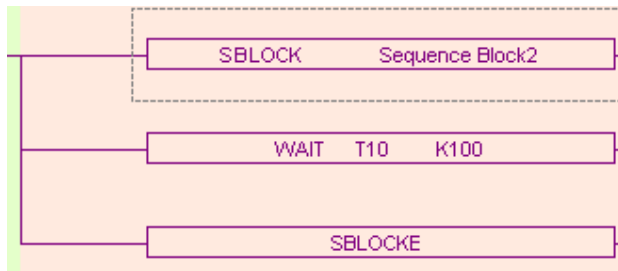

### 10-3-5. Frequency inverter item

Users only have to set the parameters in below window; the PLC will communicate with the frequency inverter.

There are four areas in the window, the following will introduce one by one:

(A) Inverter station number and serial number

Set the station number of the frequency inverter and the PLC serial port:

## (B) Control inverter action

There are two modes to set parameters.

First one is write constant value:

Second one is to set the parameters in register:

## (C) Inverter status read into

To read the status from the frequency inverter to the PLC register.

## (D) User define

To write or read the frequency inverter address flexible.

For example, add a writing inverter instruction:

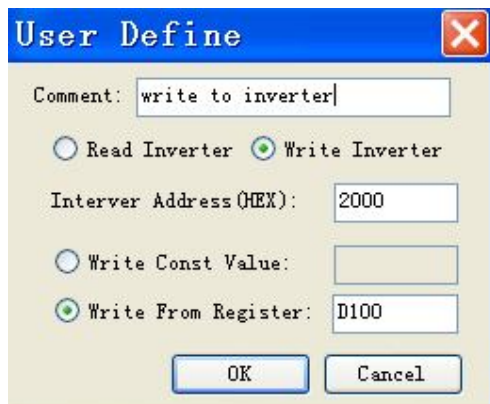

The 'User Define' dialog box is shown with the following settings:

- Comment: write to inverter
- Read Inverter  Write Inverter
- Inverter Address (HEX): 2000
- Write Const Value: [empty]
- Write From Register: D100

Add a reading inverter instruction:

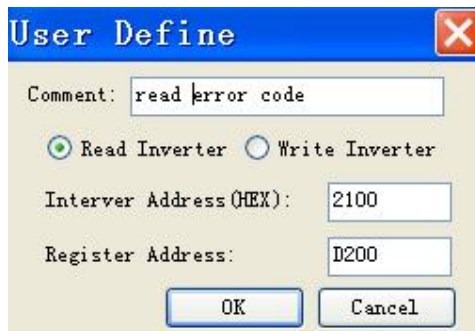

The 'User Define' dialog box is shown with the following settings:

- Comment: read error code
- Read Inverter  Write Inverter
- Inverter Address (HEX): 2100
- Register Address: D200

The result after adding:

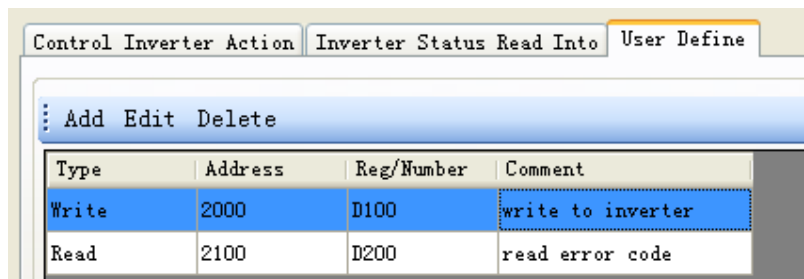

The screenshot shows the 'User Define' tab in a software interface. The table below lists the instructions added:

| Type  | Address | Reg/Number | Comment           |
|-------|---------|------------|-------------------|
| Write | 2000    | D100       | write to inverter |
| Read  | 2100    | D200       | read error code   |

---

※1: Frequency inverter instructions will not expand in the block.

---

### 10-3-6. Free format communication item

Add free format communication instructions in the block.

For example, select “send” instruction, first address set to D0, serial port is 2, 16 bits.

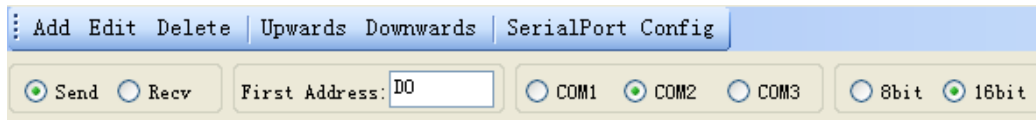

There are two methods to set the data. Const data is to set the value directly. Reg is to set the value via register.

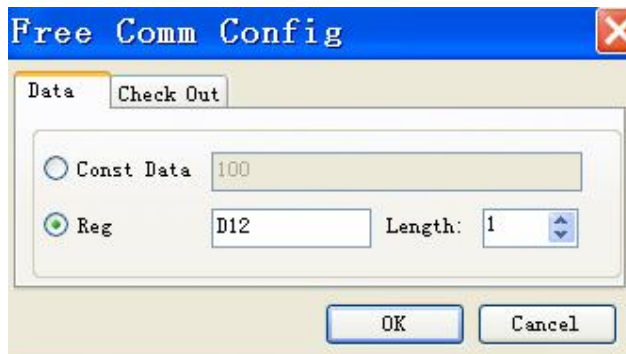
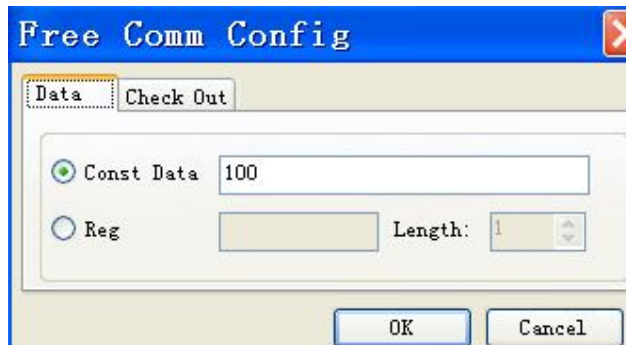

Change to check out tab, select the checking mode.

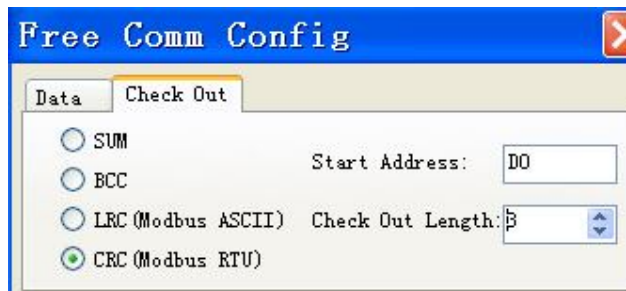

Besides, it needs to set the communication parameters. Click “serial port config”:

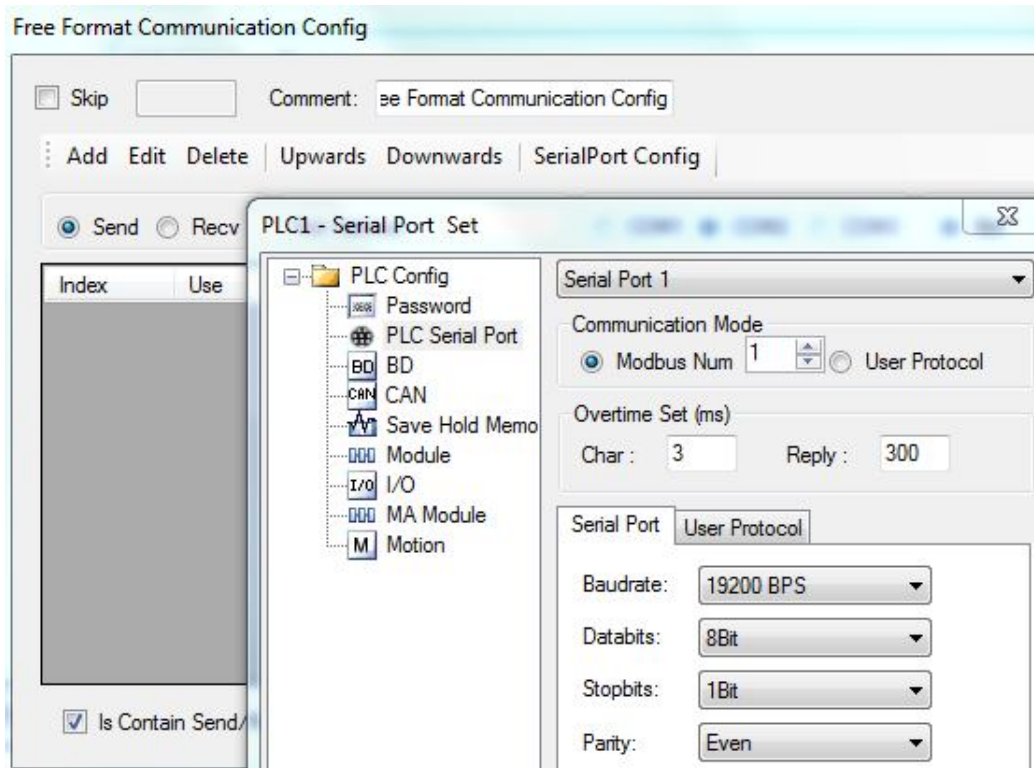

#### 10-4. Running form of the BLOCK

1. If there are many blocks, they run as the normal program. The block is running when the condition is ON.

(A) The condition is normal ON, normal OFF coil

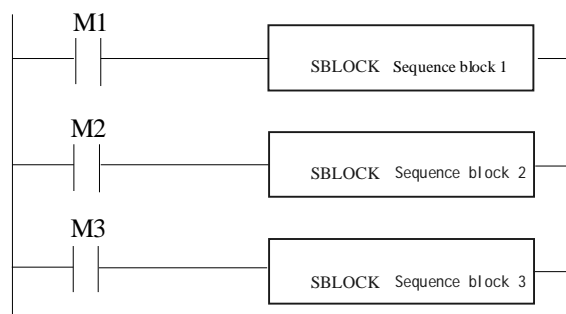

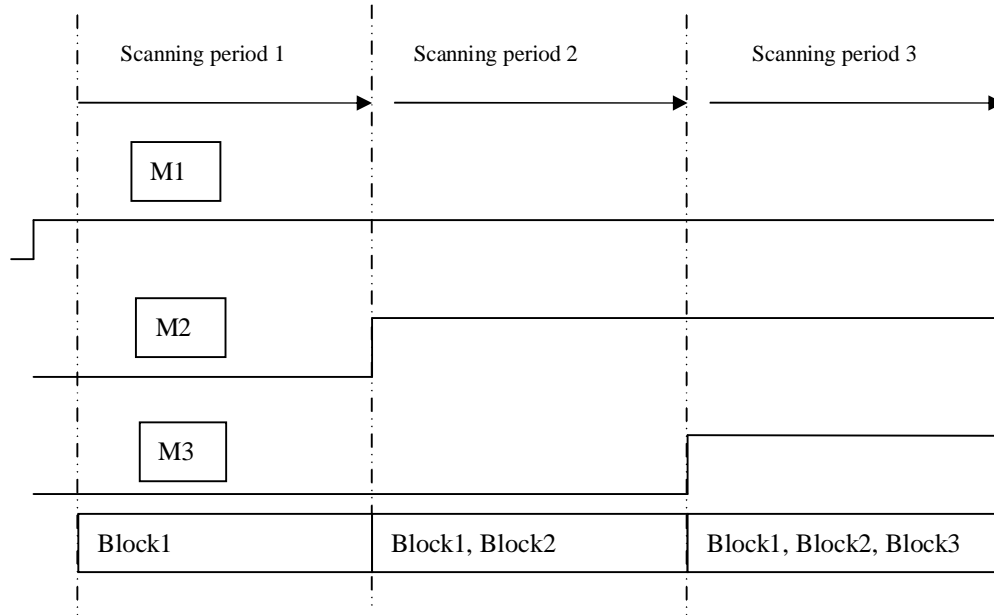

(B) The condition is rising or falling edge of pulse

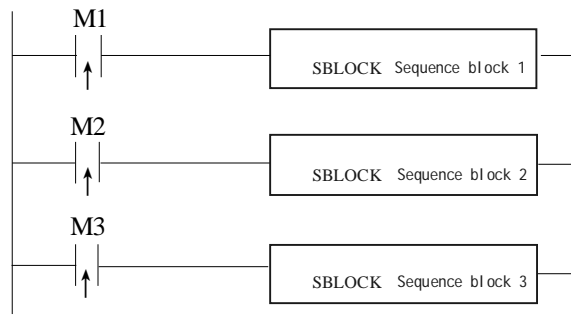

When M1, M2, M3 is from OFF to ON, all these blocks will run once.

2. The instructions in the block run in sequence according to the scanning time. They run one after another when the condition is ON.

(A) Without SKIP condition

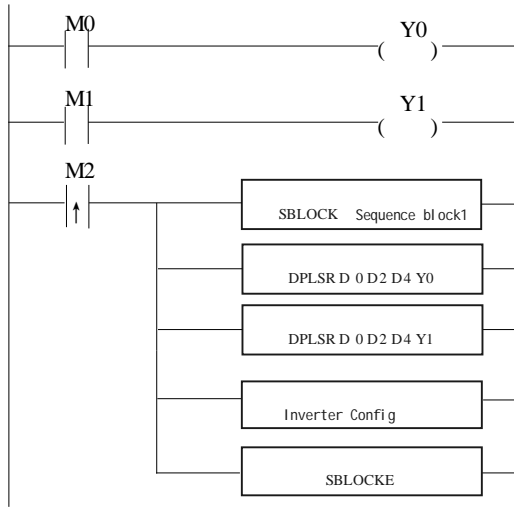

The instructions running sequence in block 1 is shown as below:

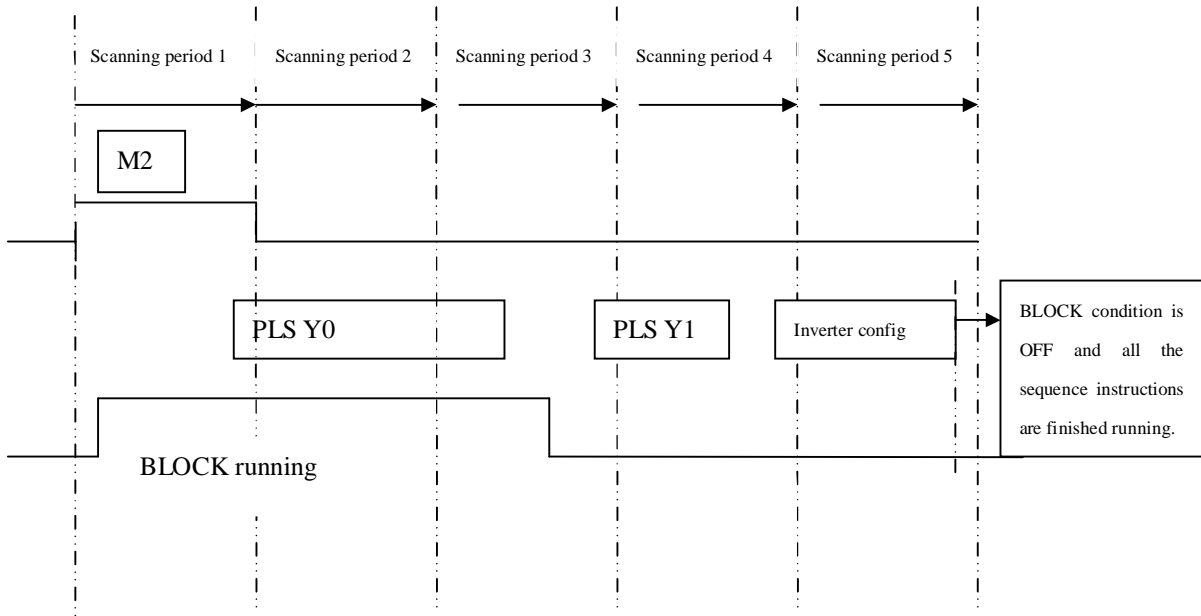

(B) With SKIP condition

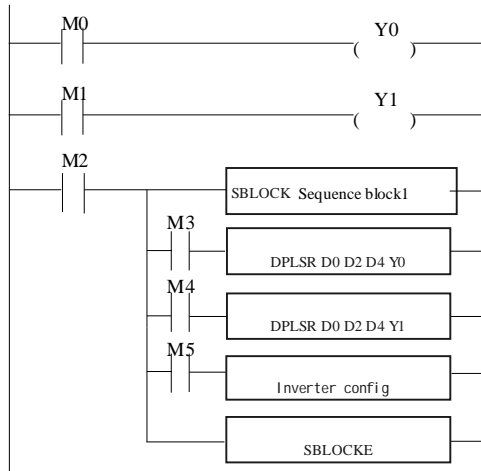

Explanation:

- A) When M2 is ON, block 1 is running.
- B) All the instructions run in sequence in the block.
- C) M3, M4, M5 are the sign of SKIP, when they are ON, this instruction will not run.
- D) When M3 is OFF, if no other instructions use this Y0 pulse , DPLSR D0 D2 D4 Y0 will run; if not, the DPLSR D0 D2 D4 Y0 will run after it is released by other instructions.
- E) After “DPLSR D0 D2 D4 Y0” is over, check M4. If M4 is OFF, check “DPLSR D0 D2 D4 Y1”, if M4 is ON, check M5. If M5 is OFF, “inverter config” will run.

#### 10-5. BLOCK instruction editing rules

In the BLOCK, the instruction editing should accord with some standards.

1. Do not use the same pulse output terminal in different BLOCK.

|        |         |
|--------|---------|
| NO (×) | YES (√) |
|--------|---------|

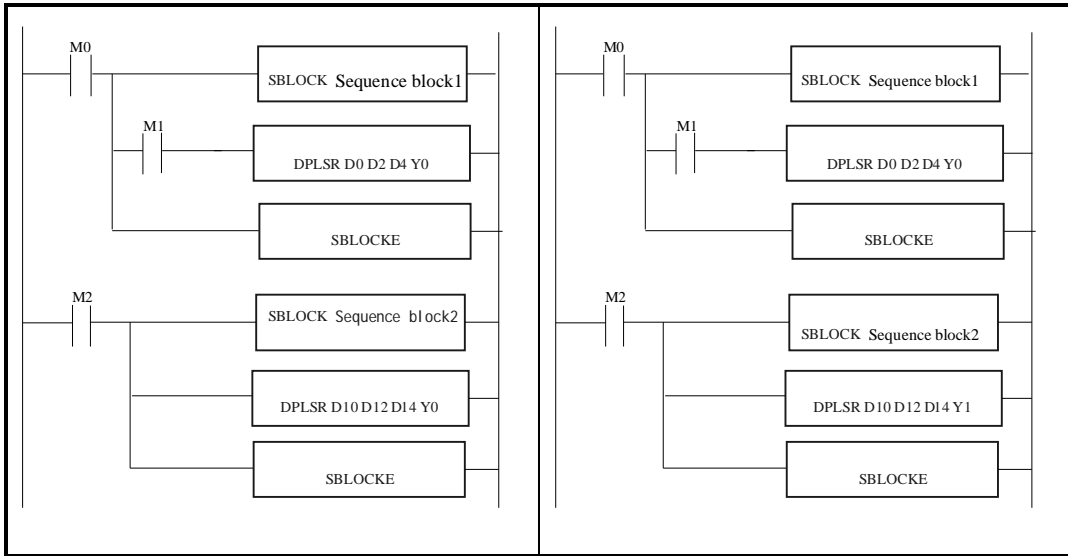

2. Do not use the same pulse output terminal in BLOCK and main program.

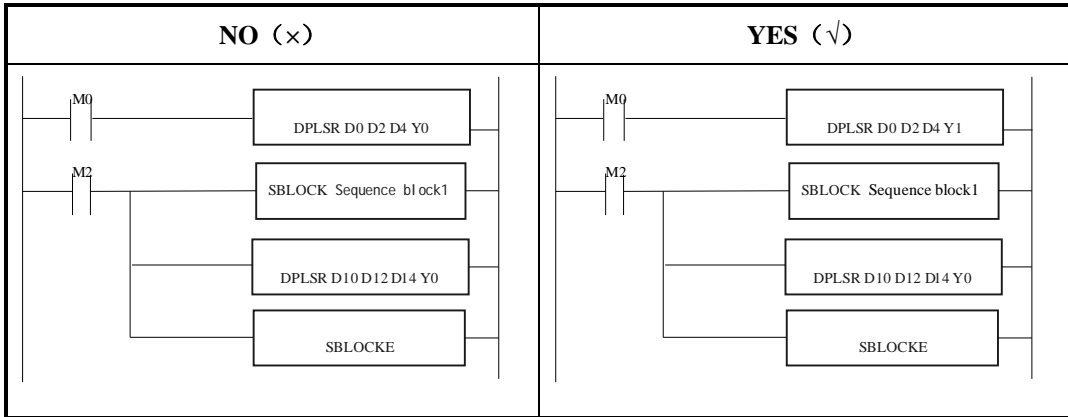

3. There only can be one SKIP condition for one BLOCK instruction.

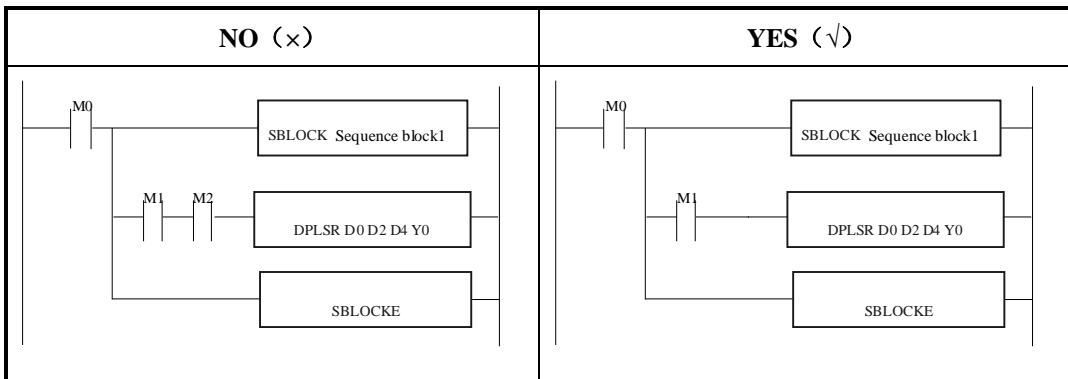

4. The SKIP condition only can use M, X, can not use other coil or register.

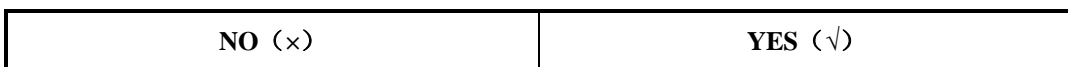

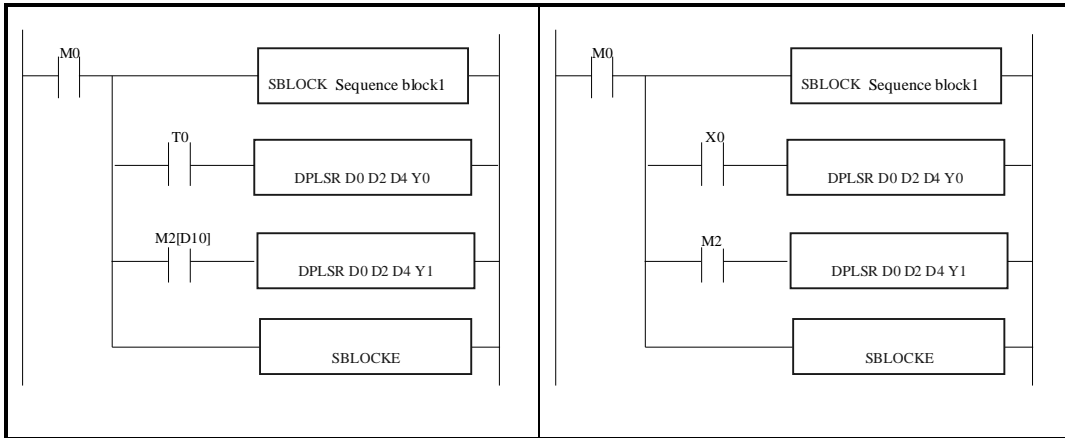

5. The output instructions cannot be HSC, PLSF, PWM, and FRQM.

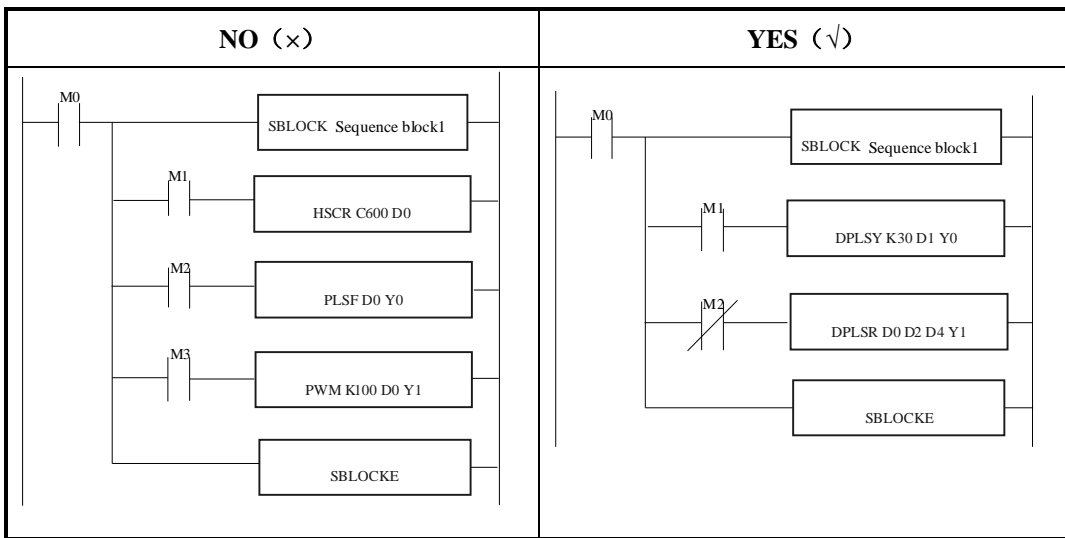

6. Label Kind type cannot be used in the block

Sign P, I can not be used in block. Even they can be added in block, but they do not work in fact.

7. BLOCK is not recommended to put in the STL. Because if one STL ends, but the BLOCK doesn't end, big problem will happen.

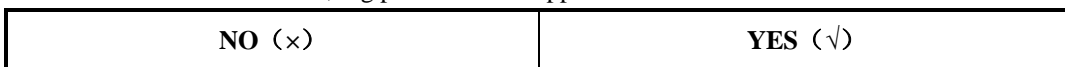

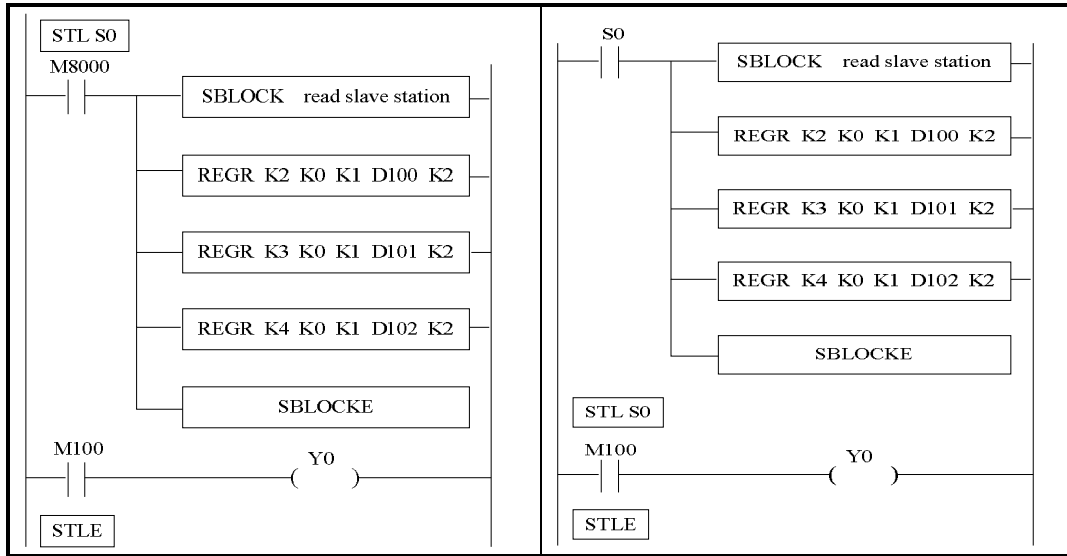

**10-6. BLOCK related instructions**

**10-6-1. Instruction explanation**

**stop running the BLOCK [SBSTOP]**

1、 Summarization

Stop the instructions running in the block

|           |                           |                |                              |
|-----------|---------------------------|----------------|------------------------------|
| [SBSTOP]  |                           |                |                              |
| 16 bits   | SBSTOP                    | 32 bits        | -                            |
| Condition | NO,NC coil and pulse edge | Suitable types | XC1, XC2, XC3, XC5, XCM, XCC |
| Hardware  |                           | Software       | -                            |

2、 Operand

| Operand | Function                   | Type         |
|---------|----------------------------|--------------|
| S1      | The number of the BLOCK    | 16 bits, BIN |
| S2      | The mode to stop the BLOCK | 16 bits, BIN |

3、 Suitable component

| Word | Operand | Register |    |    |    |    |    |    |    | Constant | Module |    |    |
|------|---------|----------|----|----|----|----|----|----|----|----------|--------|----|----|
|      |         | D        | FD | ED | TD | CD | DX | DY | DM | DS       | K/H    | ID | QD |
| S1   |         | •        |    |    |    |    |    |    |    |          | •      |    |    |
| S2   |         |          |    |    |    |    |    |    |    |          | K      |    |    |

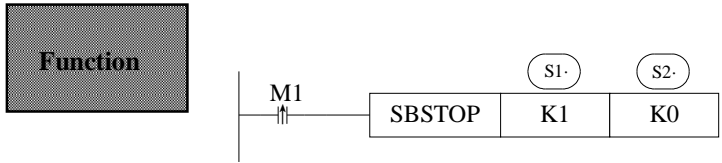

- S2 is the mode to stop BLOCK, operand K0, K1
- K0: stop the BLOCK slowly, if the pulse is outputting, the BLOCK will stop after the pulse outputting is finished.
- K1: stop the BLOCK immediately; stop all the instructions running in the BLOCK.

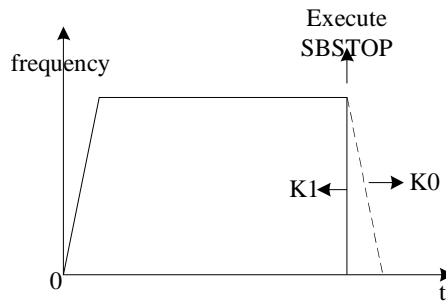

➤ Continue running the BLOCK[SBGOON]

1、 Summarization

This instruction is opposite to BSTOP. To continue running the BLOCK.

| [SBGOON]  |            |                |                              |
|-----------|------------|----------------|------------------------------|
| 16 bits   | SBGOON     | 32 bits        | -                            |
| Condition | Pulse edge | Suitable types | XC1, XC2, XC3, XC5, XCM, XCC |
| Hardware  | -          | Software       | -                            |

2、 Operand

| Operand | Function                               | Type         |
|---------|--|--------------|
| S1      | The number of the BLOCK                | 16 bits, BIN |
| S2      | The mode to continue running the BLOCK | 16 bits, BIN |

3、 Suitable component

| Word<br>Comp<br>onent | Operand | Register |    |    |    |    |    |    |    |    | Constant | Module |    |
|-----------------------|---------|----------|----|----|----|----|----|----|----|----|----------|--------|----|
|                       |         | D        | FD | ED | TD | CD | DX | DY | DM | DS | K/H      | ID     | QD |
|                       | S1      | •        |    |    |    |    |    |    |    |    | •        |        |    |
|                       | S2      |          |    |    |    |    |    |    |    |    | K        |        |    |

**Function**

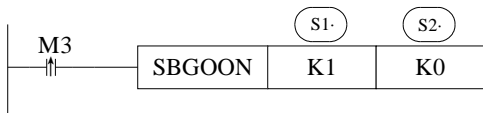

- S2 is the mode to continue running the BLOCK. Operand: K0, K1. K0: continue running the instructions in the BLOCK. For example, if pulse outputting stopped last time, SBGOON will continue outputting the rest pulse. K1: continue running the BLOCK, but abandon the instructions have not finished last time. Such as the pulse output instruction, if the pulse has not finished last time, SBGOON will not continue outputting this pulse but go to the next instruction in the BLOCK.

**10-6-2. The timing sequence of the instructions**

1. SBSTOP (K1 K1) + SBGOON (K1 K1)

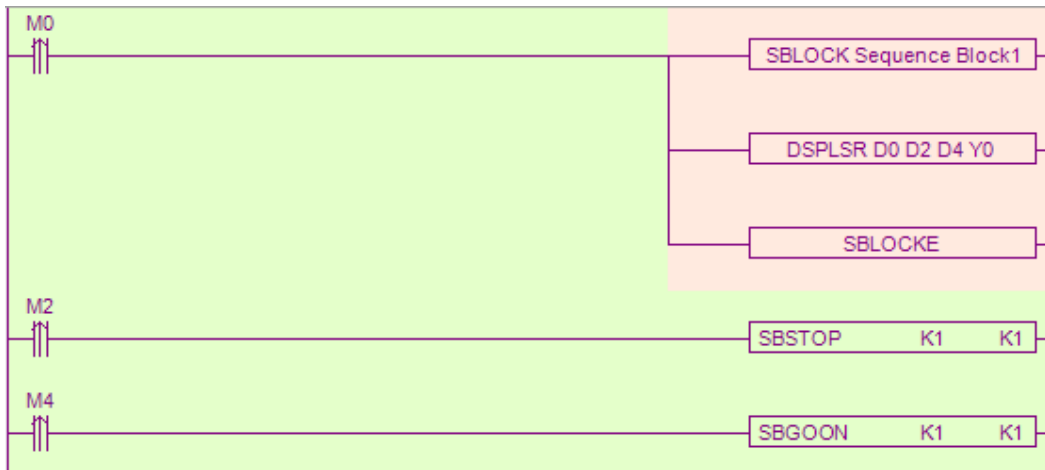

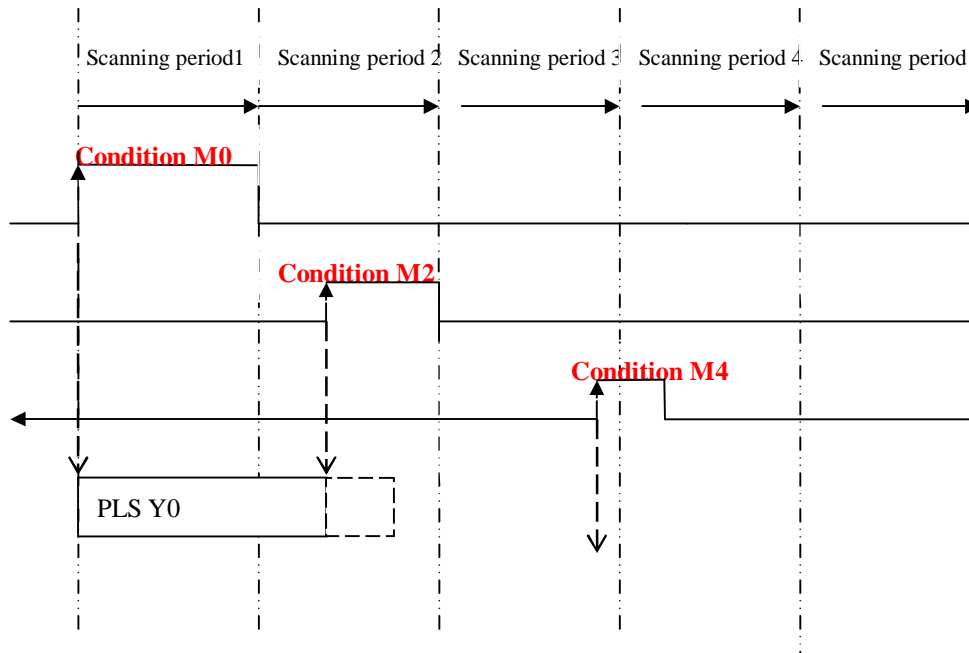

When M0 is from OFF→ON, run “DSPLSR D0 D2 D4 Y0” in the BLOCK to output the pulse;  
 when M2 is from OFF→ON, the BLOCK stops running, pulse outputting stops at once;  
 when M4 is from OFF→ON, abandon the rest pulse.

## 2. SBSTOP (K1 K1) + SBGOON (K1 K0)

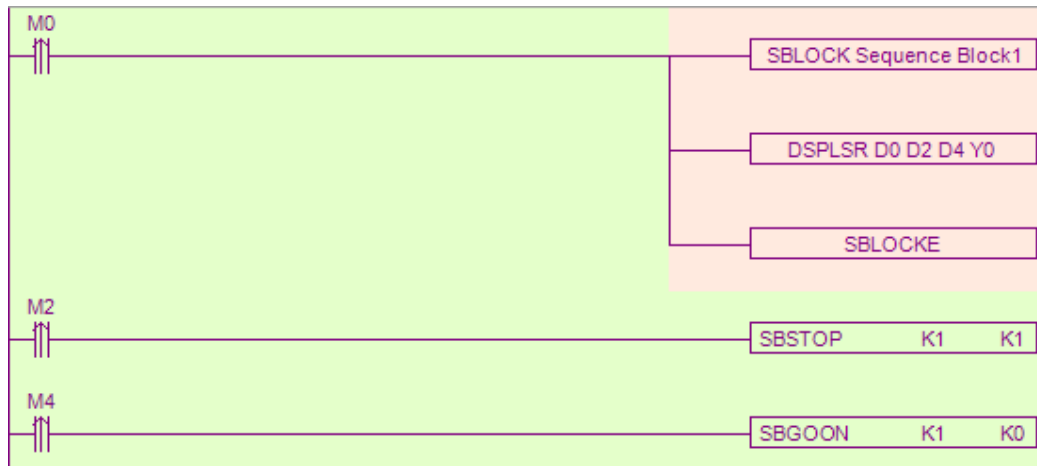

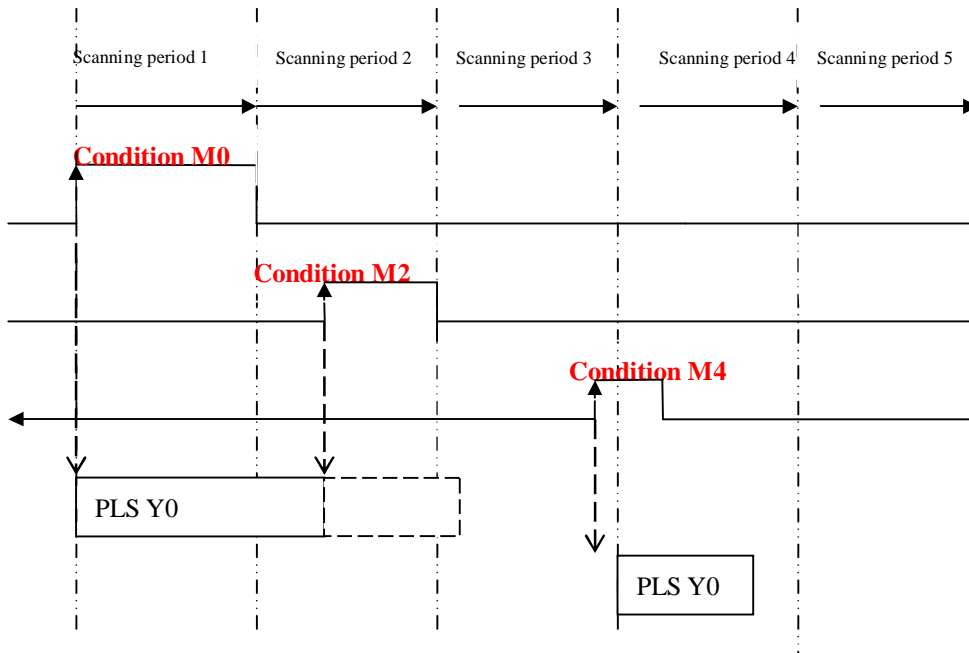

When M0 is from OFF→ON, run “DSPLSR D0 D2 D4 Y0” in the BLOCK to output the pulse; when M2 is from OFF→ON, the BLOCK stops running, the pulse outputting stops at once; when M4 is from OFF→ON, output the rest pulses.

### 3. SBSTOP (K1 K0) + SBGOON (K1 K1)

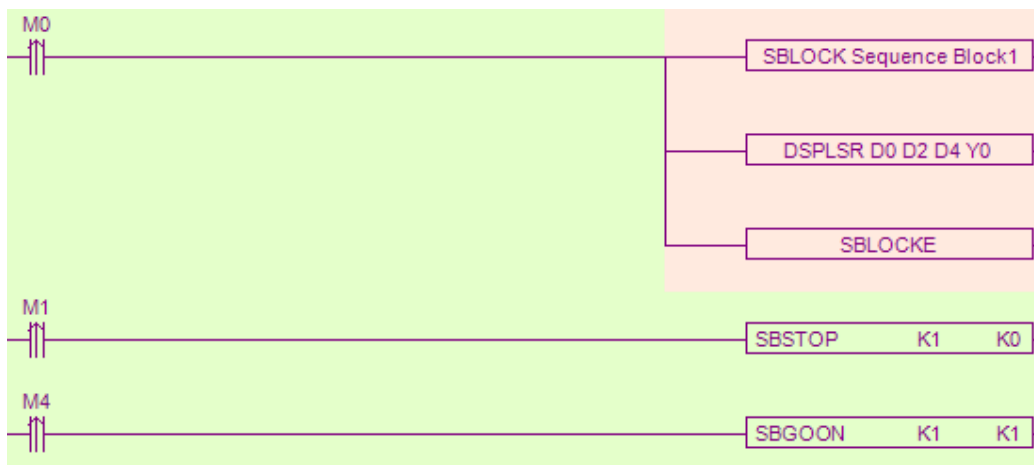

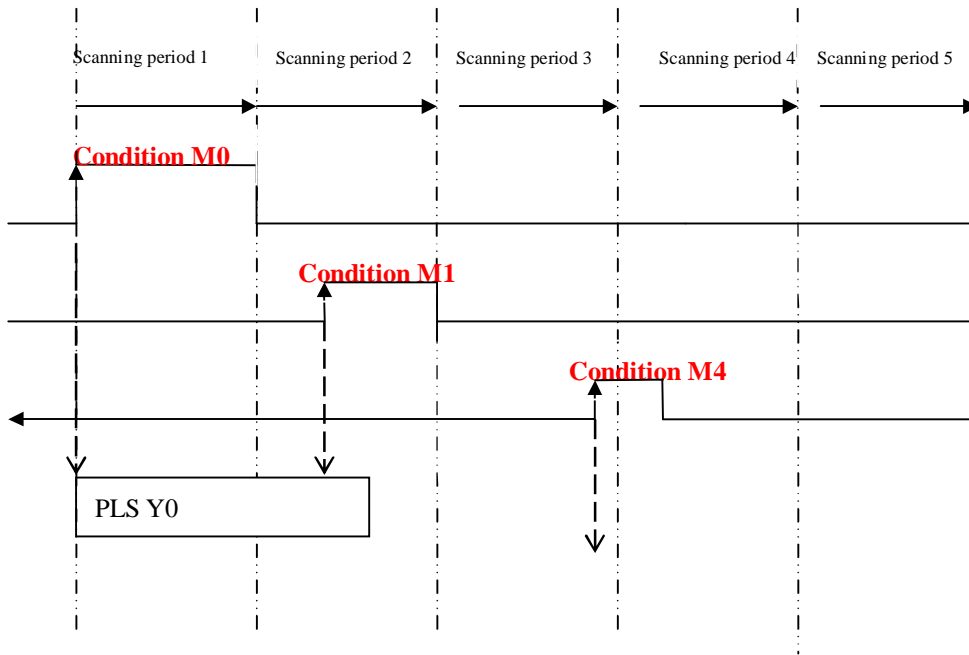

When M0 is from OFF→ON, run “DSPLSR D0 D2 D4 Y0” in the BLOCK to output the pulse; when M1 is from OFF→ON, stop the BLOCK, the pulse will stop slowly with slope, when M4 is from OFF→ON, abandon the rest pulses.

4. SBSTOP (K1 K0)+ SBGOON (K1 K0)

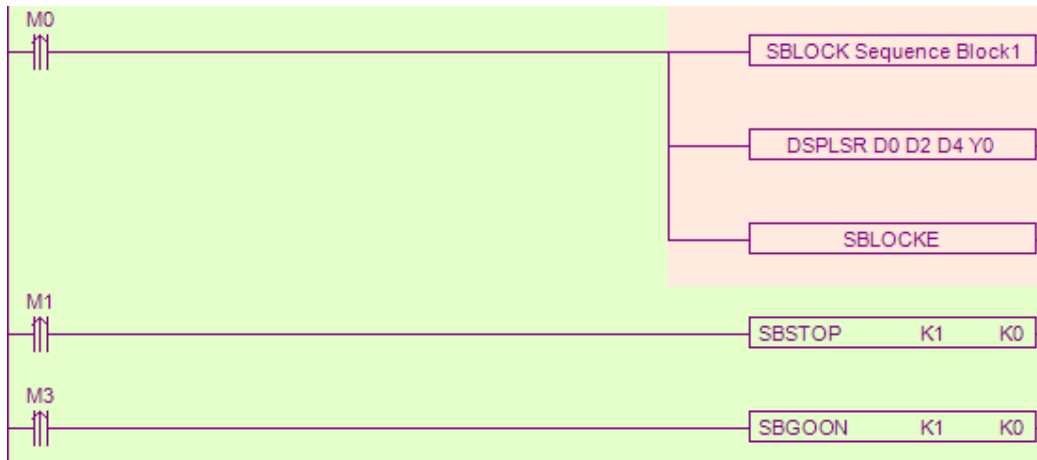

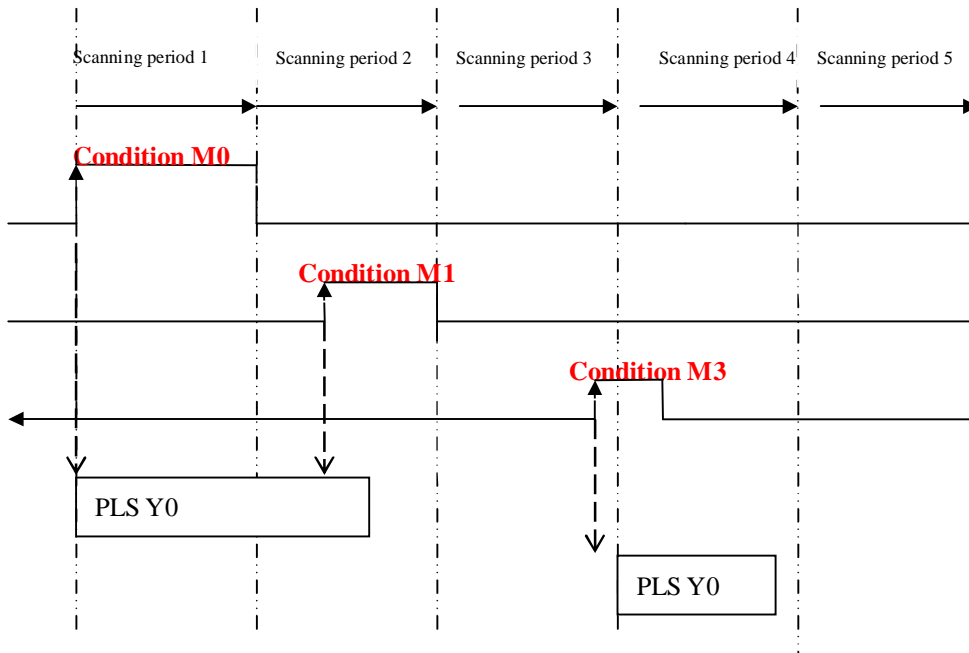

When M0 is from OFF→ON, run “DSPLSR D0 D2 D4 Y0” in the BLOCK to output the pulse; when M1 is from OFF→ON, stop running the BLOCK, the pulse will stop slowly with slope; when M3 is from OFF→ON, output the rest pulses.

Please note that though the SBSTOP stops the pulse with slope, there maybe still some pulses; in this case, if run SBGOON K1 again, it will output the rest of the pulses.

**10-7. BLOCK flag bit and register**

1、BLOCK flag bit:

| Address | Function             | Explanation                  |
|---------|----------------------|------------------------------|
| M8630   |                      | 1: running<br>0: not running |
| M8631   | BLOCK1 running flag  |                              |
| M8632   | BLOCK2 running flag  |                              |
| .....   | .....                |                              |
| .....   | .....                |                              |
| M8729   | BLOCK99 running flag |                              |

## 2、BLOCK flag register

| Address | Function                            | Explanation                          |
|---------|-------------------------------------|--------------------------------------|
| D8630   |                                     | BLOCK use this value when monitoring |
| D 8631  | BLOCK1 current running instruction  |                                      |
| D8632   | BLOCK2 current running instruction  |                                      |
| .....   | .....                               |                                      |
| .....   | .....                               |                                      |
| D8729   | BLOCK99 current running instruction |                                      |

**10-8. Program example**

Example 1:

This example is used in the tracking system. The process is like this:

Output some pulses and prohibit the exterior interruption.

Continue outputting the pulse but at low speed, and open the exterior interruption. When checked the exterior cursor signal, stop the pulse outputting and machine running.

Ladder chart:

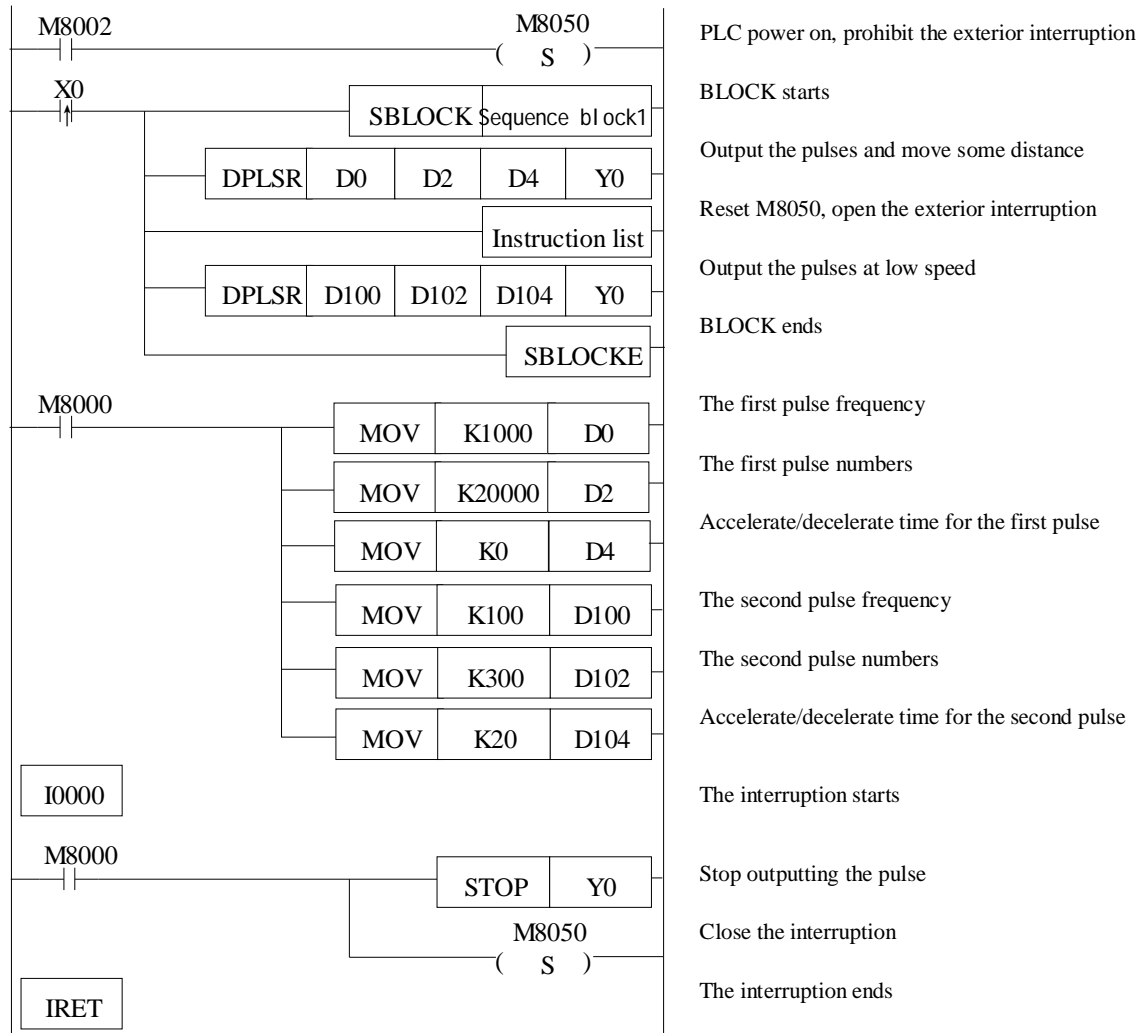

The instruction list content:  
RST M8050

Notes:  
M8050: prohibit the exterior interruption

Example 2:

One PLC (master station no.1) communicates with 3 PLCs (slave station no. 2, 3, 4) via serial port 2 RS485. Master PLC needs to read the D0 value of 3 PLCs. Then store the value in master PLC D100~D102.

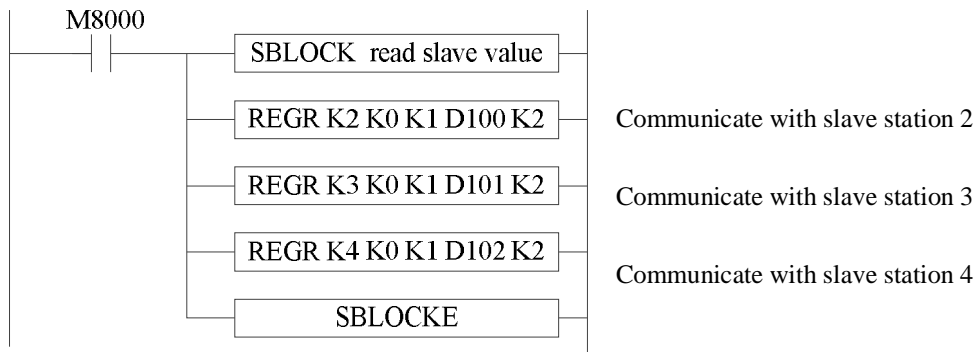

M8000 is normal ON coil, the master PLC can real-time communicate with slave PLCs.

# 11 Special Function Instructions

---

In this chapter, we mainly introduce PWM pulse width modulation, frequency detect, precise time, interruption etc;







11-1. PWM Pulse Width Modulation

11-2. Frequency Detect

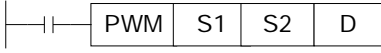
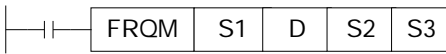
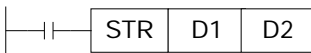
11-3. Precise Time

11-4. Interruption

## Instructions List

| Mnemonic   | Function   | Circuit and soft components   | Chapter |
|--|--|---|---------|
| <b>Pulse Width Modulation, Frequency Detection</b> |  |   |         |
| PWM  | Output pulse with the specified occupied ratio and frequency |   | 11-1    |
| FRQM   | Frequency Detection  |   | 11-2    |
| <b>Time</b>  |  |   |         |
| STR  | Precise Time   |   | 11-3    |
| STRR   | Read Precise Time Register                                   |   | 11-3    |
| STRS   | Stop Precise Time  |   | 11-3    |
| <b>Interruption</b>                                |  |   |         |
| EI   | Enable Interruption  |  | 11-4-1  |
| DI   | Disable Interruption   |  | 11-4-1  |
| IRET   | Interruption Return  |  | 11-4-1  |

**11-1. PWM Pulse Width Modulation**

1、Instruction's Summary

Instruction to realize PWM pulse width modulation

| PWM pulse width modulation [PWM] |                      |                      |                     |
|----------------------------------|----------------------|----------------------|---------------------|
| 16 bits instruction              | PWM                  | 32 bits instruction  | -                   |
| execution condition              | normally ON/OFF coil | suitable models      | XC2、XC3、XC5、XCM、XCC |
| hardware requirement             | -                    | software requirement | -                   |

2、Operands

| Operands | Function   | Type         |
|----------|--|--------------|
| S1       | specify the occupy ratio value or soft component's ID number | 16 bits, BIN |
| S2       | specify the output frequency or soft component's ID number   | 16 bits, BIN |
| D        | specify the pulse output port                                | bit          |

3、Suitable Soft Components

|      |          |        |    |    |    |    |    |     |    |          |        |    |    |
|------|----------|--------|----|----|----|----|----|-----|----|----------|--------|----|----|
| Word | Operands | System |    |    |    |    |    |     |    | Constant | Module |    |    |
|      |          | D      | FD | ED | TD | CD | DX | DY  | DM | DS       | K/H    | ID | QD |
|      | S1       | •      | •  |    | •  | •  |    |     |    |          | •      |    |    |
| S2   | •        | •      |    | •  | •  |    |    |     |    | •        |        |    |    |
| Bit  | Operands | System |    |    |    |    |    |     |    |          |        |    |    |
|      |          | X      | Y  | M  | S  | T  | C  | Dnm |    |          |        |    |    |
|      | D        |        | •  |    |    |    |    |     |    |          |        |    |    |

**Function and Action**

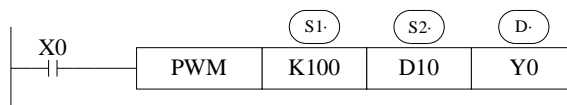

- The occupy ratio **n**: 1~255
- Output pulse **f**: 0~72KHz
- Pulse is output at Y0 or Y1 (Please use transistor output)
- The output occupy empty ratio of PMW =  $n / 256 \times 100\%$
- PWM output use the unit of 0.1Hz, so when set (S2) frequency, the set value is 10 times of the actual frequency (i.e. 10f). E.g.: to set the frequency as 72 KHz, and then set value in (S2) is 720000.
- When X000 is ON, output PWM wave; When X000 is OFF, stop output. PMW output doesn't have pulse accumulation.

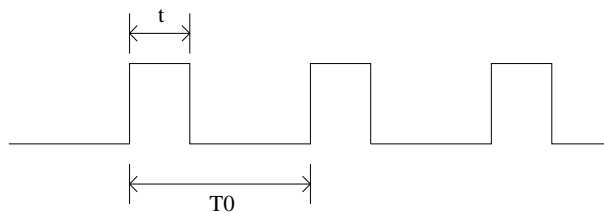

In the left graph:  $T0=1/f$   
 $T/T0=n/256$

**11-2. Frequency Testing**

1、Instruction's Summary

Instruction to realize frequency testing

| frequency testing [FRQM] |                      |                      |                 |
|--------------------------|----------------------|----------------------|-----------------|
| 16 bits instruction      | FRQM                 | 32 bits instruction  | -               |
| execution condition      | normally ON/OFF coil | suitable models      | XC2、XC3、XC5、XCM |
| hardware requirement     | -                    | software requirement | -               |

2、Operands

| Operands | Function  | Type         |
|----------|---|--------------|
| S1       | Specify the sampling pulse quantity or soft component's ID number | 32 bits, BIN |
| S2       | Specify the frequency division value                              | 32 bits, BIN |
| S3       | Specify the pulse input port                                      | bit          |
| D        | specify the tested result's soft component's number               | 32 bits, BIN |

3、Suitable Soft Components

|      |          |        |    |    |    |    |    |     |    |          |        |    |    |
|------|----------|--------|----|----|----|----|----|-----|----|----------|--------|----|----|
| Word | Operands | System |    |    |    |    |    |     |    | Constant | Module |    |    |
|      |          | D      | FD | ED | TD | CD | DX | DY  | DM | DS       | K/H    | ID | QD |
|      | S1       | •      |    |    | •  | •  |    |     |    |          | •      |    |    |
|      | S2       |        |    |    |    |    |    |     |    |          | •      |    |    |
| D    | •        |        |    | •  | •  |    |    |     |    |          |        |    |    |
| Bit  | Operands | System |    |    |    |    |    |     |    |          |        |    |    |
|      |          | X      | Y  | M  | S  | T  | C  | Dnm |    |          |        |    |    |
|      | S3       | •      |    |    |    |    |    |     |    |          |        |    |    |

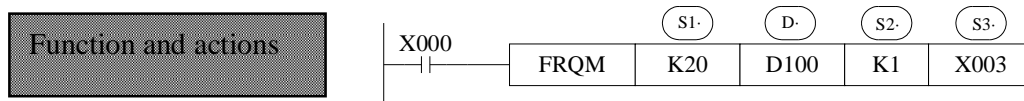

- S1: sampling pulse quantity: the number to calculate the pulse frequency, this parameter can be changed as the frequency (generally, the higher the frequency the larger the pulse quantity)
- D: tested result, the unit is Hz.
- S2: Frequency division choice. Range: K1 or K2;  
Whatever K1 or K2, the effect is the same. Testing frequency range is 1~200 KHz.
- The testing precision will change when the frequency increasing. 1~80 KHz, precision is 100%; 80~200 KHz, precision is 99.5%.
- When X0 is ON, FRQM will test 20 pulses from X3 every scan cycle. Calculate the frequency's value and save into D100. Test repeat. If the tested frequency's value is smaller than the test range, then return the test value is 0.

**The pulse output to X number:**

| Type |                   | X terminal |
|------|-------------------|------------|
| XC2  | 14/16/24/32/48/60 | X1         |
| XC3  | 24/32/42          | X1         |
| XC5  | 48/60             | X1         |
| XCM  | 60                | X1         |

### 11-3. Precise Time

#### 1、Instruction List

Read and stop precise time when execute precise time;

| precise time [STR]       |                 |                       |                     |
|--------------------------|-----------------|-----------------------|---------------------|
| 16 bits instruction      | -               | 32 bits instruction   | STR                 |
| execution condition      | edge activation | suitable models       | XC2、XC3、XC5、XCM、XCC |
| hardware requirement     | -               | software requirements | -                   |
| read precise time [STRR] |                 |                       |                     |
| 16 bits instruction      | -               | 32 bits instruction   | STRR                |
| execution condition      | edge activation | suitable models       | XC2、XC3、XC5、XCM、XCC |
| hardware requirement     | V3.0e and above | software requirements | -                   |
| stop precise time [STRS] |                 |                       |                     |
| 16 bits instruction      | -               | 32 bits instruction   | STRS                |
| execution condition      | edge activation | suitable models       | XC2、XC3、XC5、XCM、XCC |
| hardware requirement     | V3.0e and above | software requirements | -                   |

#### 2、Operands

| Operands | Function  | Type         |
|----------|---|--------------|
| D        | Timer Number  | bit          |
| D1       | Timer Number  | bit          |
| D2       | specify timer's value or soft component's ID number | 16 bits, BIN |

#### 3、Suitable Soft Components

|      |          |        |    |    |    |    |    |     |    |          |        |    |    |
|------|----------|--------|----|----|----|----|----|-----|----|----------|--------|----|----|
| Word | operands | system |    |    |    |    |    |     |    | constant | module |    |    |
|      |          | D      | FD | ED | TD | CD | DX | DY  | DM | DS       | K/H    | ID | QD |
|      | D2       | •      | •  |    | •  | •  |    |     |    |          | •      |    |    |
| Bit  | operands | system |    |    |    |    |    |     |    |          |        |    |    |
|      |          | X      | Y  | M  | S  | T  | C  | Dnm |    |          |        |    |    |
|      | D        |        |    |    |    | •  |    |     |    |          |        |    |    |
|      | D1       |        |    |    |    | •  |    |     |    |          |        |    |    |

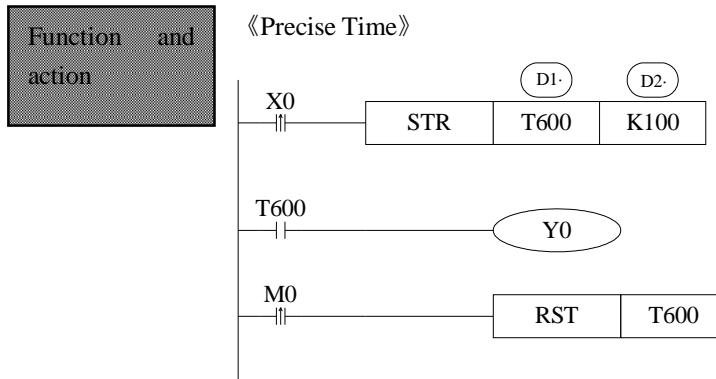

D1: Timer's number. Range: T600~T618 (T600、T602、T604...T618, the number should be even)

D2: Time Value

- The precise timer works in form of 1ms
- The precise timer is 32 bits, the count range is 0~+2,147,483,647.
- When executing STR, the timer will be reset before start timing.
- When X0 turns from OFF to ON, timer T600 starts to time, when time accumulation reaches 100ms, set T600; if X0 again turns from OFF to ON, timer T600 turns from ON to OFF, restart to time, when time accumulation reaches 100ms, T600 reset again. See graph below:

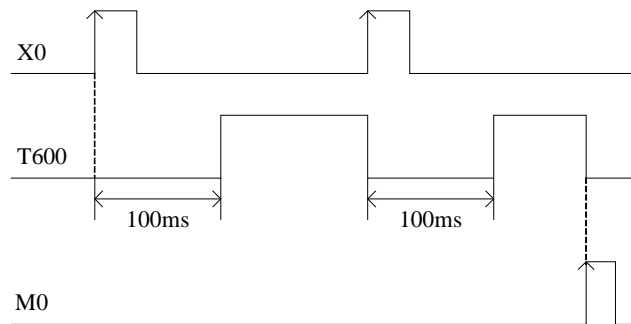

《read the precise time》、《stop precise time》

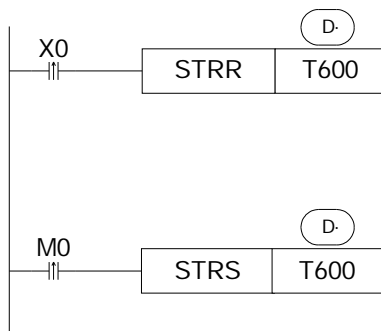

- When X0 changes from OFF to ON, move the current precise time value into TD600 immediately, it will not be affected by the scan cycle;
- When M0 changes from OFF to ON, execute STRS instruction immediately, stop precise time and refresh the count value in TD600. It will not be affected by the scan cycle;

### Precise Time Interruption

- When the precise time reaches the count value, it will generate an interruption tag, interruption subprogram will be executed.
- Start the precise time in precise time interruption;
- Every precise timer has its own interruption tag, see table below:

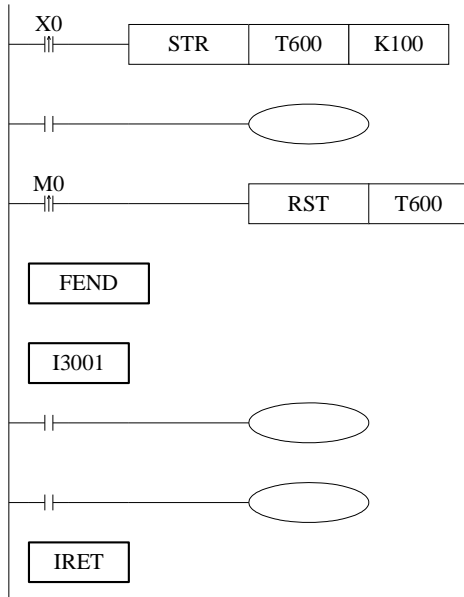

When X0 changes from OFF to ON, T600 will start timing. When time accumulates to 100ms, set ON T600; meantime, generate an interruption, the program jumps to interruption tag I3001 and execute the subprogram.

**Interruption Tag correspond to the Timer**

| Timer's Nr. | Interruption Tag |
|-------------|------------------|
| T600        | I3001            |
| T602        | I3002            |
| T604        | I3003            |
| T606        | I3004            |
| T608        | I3005            |
| T610        | I3006            |
| T612        | I3007            |
| T614        | I3008            |
| T616        | I3009            |
| T618        | I3010            |

## 11-4. Interruption

XC series PLC are equipped with interruption function. The interruption function includes external interruption and time interruption. Via interruption function we can dispose some special programs. This function is not affected by the scan cycle.

### 11-4-1. External Interruption

The input terminals X can be used to input external interruption. Each input terminal corresponds with one external interruption. The input's rising/falling edge can activate the interruption. The interruption subroutine is written behind the main program (behind FEND). After interruption generates, the main program stops running immediately, turn to run the correspond subroutine. After subroutine running ends, continue to execute the main program.

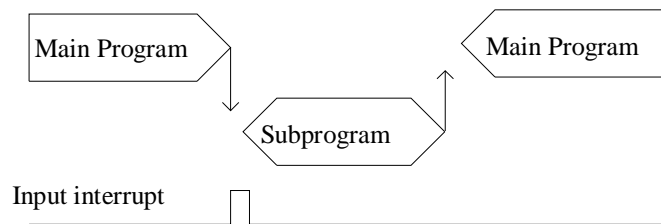

### External Interruption's Port Definition

#### XC3-14

| Input Terminal | Pointer No.         |                      | Disable the interruption instruction |
|----------------|---------------------|----------------------|--------------------------------------|
|                | Rising Interruption | Falling Interruption |                                      |
| X7             | I0000               | I0001                | M8050                                |

#### XC2-14/16

| Input terminal | Pointer No.         |                      | Disable the interruption instruction |
|----------------|---------------------|----------------------|--------------------------------------|
|                | Rising interruption | Falling interruption |                                      |
| X2             | I0000               | I0001                | M8050                                |
| X5             | I0100               | I0101                | M8051                                |

#### XC2-24/32/48/60、XC3-24/32/42、XC5-24/32/48/60

| Input Terminal | Pointer No.         |                      | Disable the interruption instruction |
|----------------|---------------------|----------------------|--------------------------------------|
|                | Rising Interruption | Falling Interruption |                                      |
| X2             | I0000               | I0001                | M8050                                |
| X5             | I0100               | I0101                | M8051                                |
| X10            | I0200               | I0201                | M8052                                |

**XC3-48/60、XC3-19AR-E**

| Input Terminal | Pointer No.         |                      | Disable the interruption instruction |
|----------------|---------------------|----------------------|--------------------------------------|
|                | Rising Interruption | Falling Interruption |                                      |
| X10            | I0000               | I0001                | M8050                                |
| X7             | I0100               | I0101                | M8051                                |
| X6             | I0200               | I0201                | M8052                                |

**XCM-24/32 (3 or 4 axis output)**

| Input Terminal | Pointer No.         |                      | Disable the interruption instruction |
|----------------|---------------------|----------------------|--------------------------------------|
|                | Rising Interruption | Falling Interruption |                                      |
| X2             | I0000               | I0001                | M8050                                |
| X5             | I0100               | I0101                | M8051                                |
| X10            | I0200               | I0201                | M8052                                |
| X11            | I0300               | I0301                | M8053                                |
| X12            | I0400               | I0401                | M8054                                |
| X13            | I0500               | I0501                | M8055                                |

**XCM-60**

| Input Terminal | Pointer No.         |                      | Disable the interruption instruction |
|----------------|---------------------|----------------------|--------------------------------------|
|                | Rising Interruption | Falling Interruption |                                      |
| X2             | I0000               | I0001                | M8050                                |
| X3             | I0100               | I0101                | M8051                                |
| X4             | I0200               | I0201                | M8052                                |
| X5             | I0300               | I0301                | M8053                                |

**XCC-24**

| Input Terminal | Pointer No.         |                      | Disable the interruption instruction |
|----------------|---------------------|----------------------|--------------------------------------|
|                | Rising Interruption | Falling Interruption |                                      |
| X14            | I0000               | I0001                | M8050                                |
| X15            | I0100               | I0101                | M8051                                |

**XCC-32**

| Input Terminal | Pointer No.         |                      | Disable the interruption instruction |
|----------------|---------------------|----------------------|--------------------------------------|
|                | Rising Interruption | Falling Interruption |                                      |
| X14            | I0000               | I0001                | M8050                                |
| X15            | I0100               | I0101                | M8051                                |
| X16            | I0200               | I0201                | M8052                                |

X17

I0300

I0301

M8053

## Interruption Instruction

Enable Interruption [EI], Disable Interruption [DI], Interruption Return [IRET]

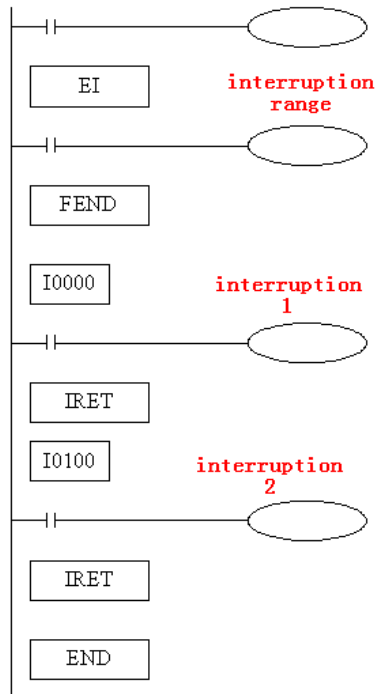

- If use EI instruction to allow interruption, then when scanning the program, if interruption input changes from OFF to be ON, then execute subroutine①、②, return to the original main program;
- Interruption pointer (I\*\*\*\*) should be behind FEND instruction;
- PLC is default to allow interruption

## Interruption's Range Limitation

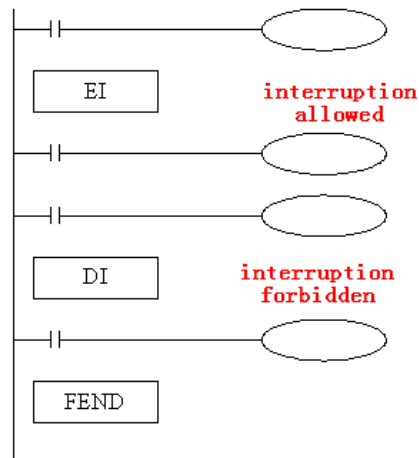

- Via program with DI instruction, set interruption forbidden area;
- Allow interruption input between EI~DI
- If interruption forbidden is not required, please program only with EI, program with DI is not required.

## Disable the Interruption

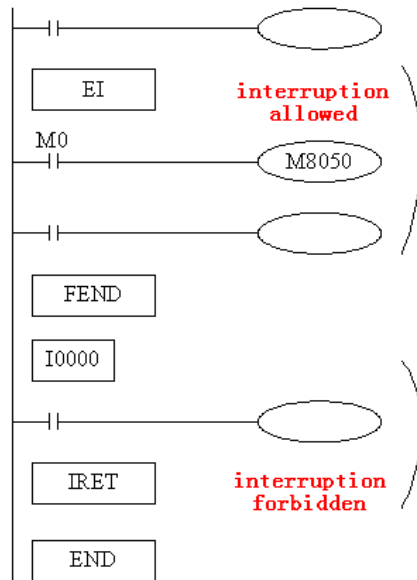

- Every input interruption is equipped with special relay (M8050~M8052) to disable interruption;
- In the left program, if use M0 to set M8050 “ON”, then disable the interruption input at channel 0.

### 11-4-2. Time Interruption

#### FUNCTIONS AND ACTIONS

In the condition of main program’s execution cycle long, if you need to handle a special program; or during the sequential scanning, a special program needs to be executed at every certain time, time interruption function is required. This function is not affected by PLC’s scan cycle, every Nm, execute time interruption subroutine.

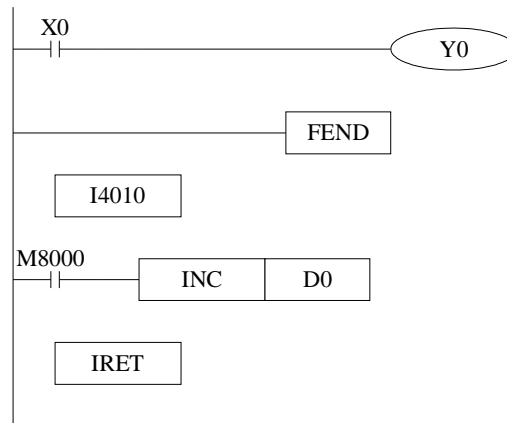

- Time interrupt is default in open status, time interrupt subroutine is similar with other interrupt subroutine, it should be written behind the main program, starts with I40xx, ends with IRET.
- There are 10CH time interrupts. The represent method is I40\*\*~I49\*\* (“\*\*”) means time interrupt’s time, unit is ms. For example, I4010 means run one channel time interrupt every 10ms.

### Interruption No

| Interruption No. | Interruption Forbidden Instruction | Description  |
|------------------|------------------------------------|--|
| I40**            | M8056                              | ** represents time interrupt’s time, range from 1 to 99, unit is ms. |
| I41**            | M8057                              |  |
| I42**            | M8058                              |  |
| I43**            | -                                  |  |
| I44**            | -                                  |  |
| I45**            | -                                  |  |
| I46**            | -                                  |  |
| I47**            | -                                  |  |
| I48**            | -                                  |  |
| I49**            | -                                  |  |

**Interruption range's limitation**

- Normally time interruption is in “allow” status
- With EI、DI can set interruption's allow or forbidden area. As in the above graph, all time interruptions are forbidden between DI~EI, and allowed beyond DI~EI.

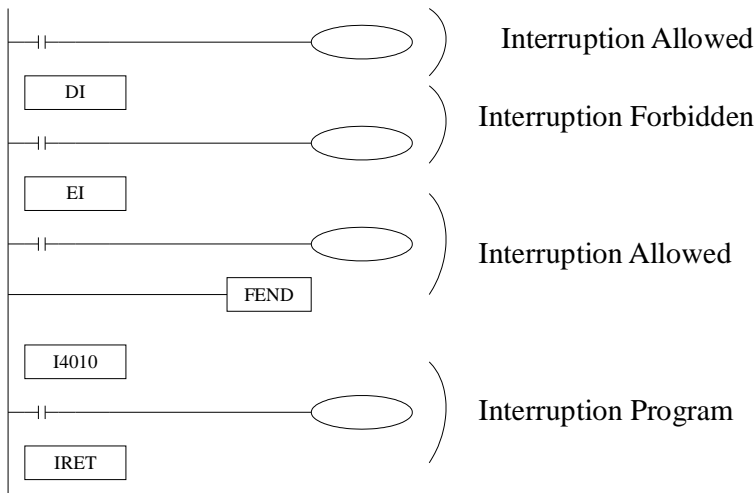

**Interruption Forbidden**

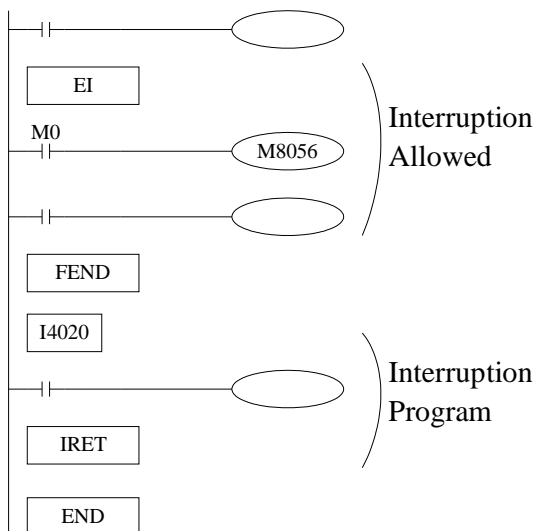

- The first 3CH interruptions are equipped with special relays (M8056~M8059) to forbid interrupt
- In the left example program, if use M0 to enable M8056 “ON”, the forbid 0CH's time interruption.

---

# 12 Application Program Samples

---

In this chapter, we make some samples about pulse output instruction, Modbus communication instructions and free format communication instructions etc.

12-1. Pulse Output Sample

12-2. Modbus Communication Sample

12-3. Free Format Communication Sample

## 12-1. Pulse Output Application

Example: send high frequency and low frequency of pulse

Parameters:

Stepping motor parameters: step angle= 1.8 degrees/step, scale=40, pulse number per rotate is 8000

High frequency pulse: maximum frequency is 100 KHz, total pulse number is 24000 (3 rotate)

Low frequency pulse: maximum frequency is 10 KHz, total pulse number is 8000 (1 rotates)

Ladder Program:

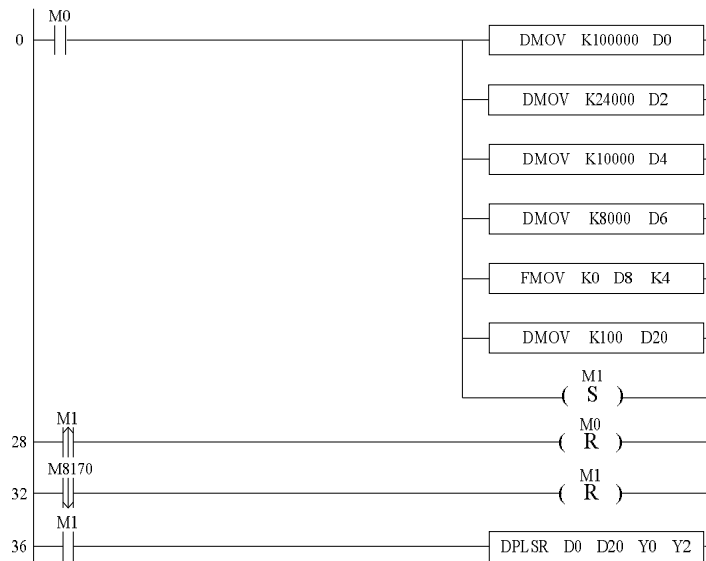

Explanation:

When PLC changes from STOP to RUN, set ON M0, set the high frequency parameter D0, D2, low frequency parameter D4, D6, speed up/down time D20, clear D8~D11, set ON M1, set OFF M0. The motor rotates at high frequency for 3 turns, set ON M8170; then the motor rotates at low frequency for 1 turn, set OFF M8170, set OFF M1.

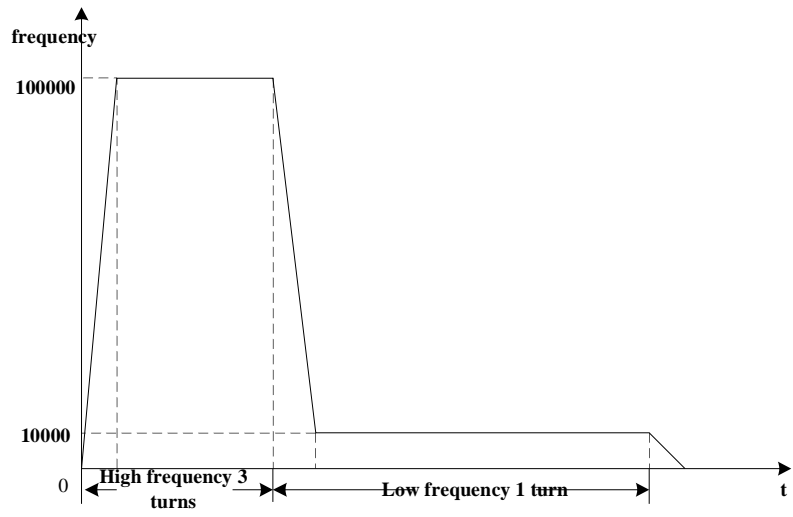

---

## 12-2. MODBUS COMMUNICATION SAMPLES

**Example 1:** one master station communicates with 3 slave stations.

Operation:

(1) Write content in D10~D14 to D10~D14 of slave station 2;  
(2) Read D15~D19 of the slave station 2 to D15~D19 of the mater station; anyhow, write the first five registers' content to the slaves, the left five registers are used to store the content from the slaves;

(3) Slave station 3 and 4 are similar;

Soft component's comments:

D0: communication station number

D1: offset

M2: station 2 communication error

M3: station 3 communication error

M4: station 4 communication error

M8137: COM2 communication error end signal

M8138: COM2 communication correct end signal

S0: write the target station

S1: read the target station

S2: judge the communication status

S3: offset the communication address

T200: communication interval 1

T201: communication interval 2

D20: plus one for write error times

D21: plus one for read error times

Ladder chart

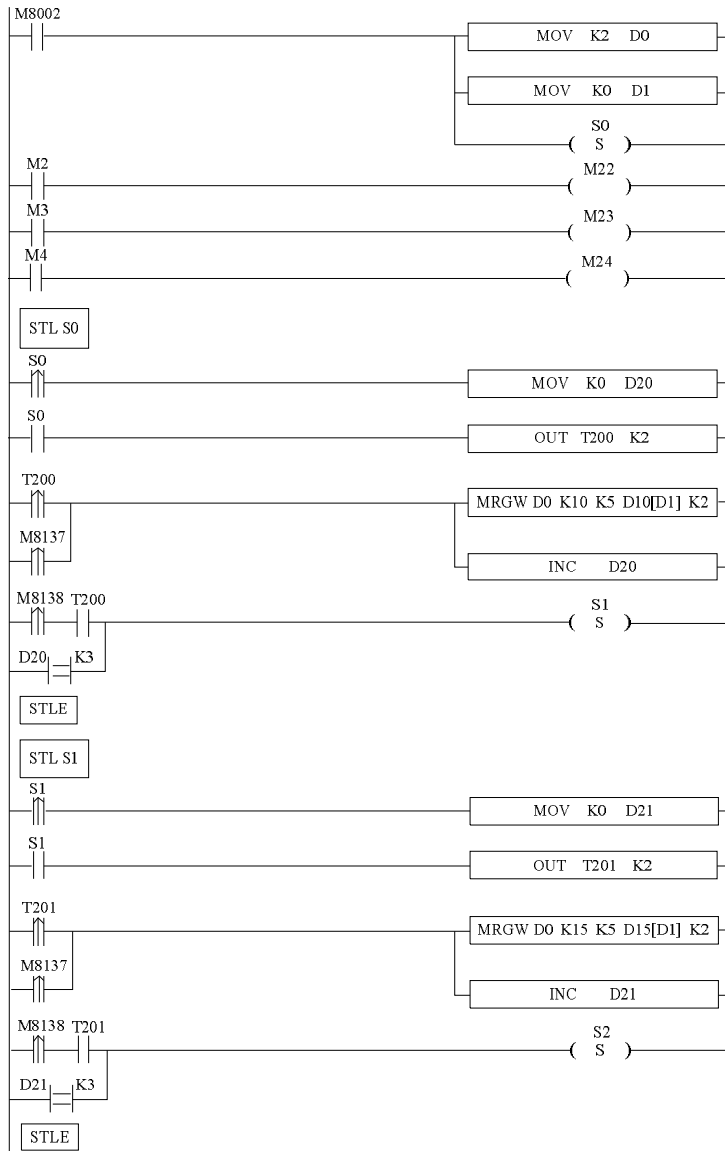

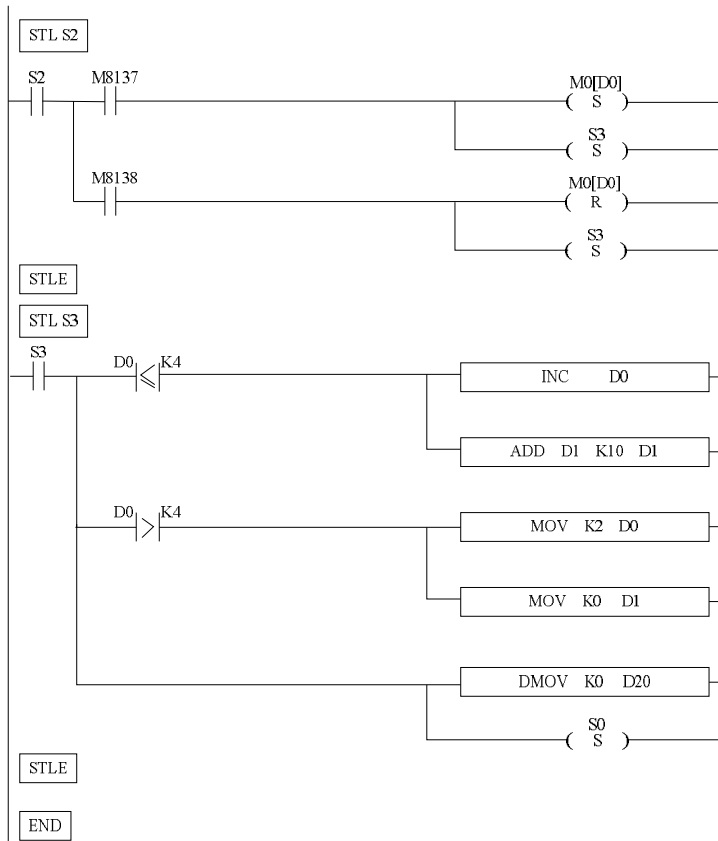

**Program Explanation:**

When PLC turns from STOP to RUN, M8002 gets a scan cycle. S0 flow open, write the master's D10~D14 to slave 2 D10~D14. If the communication is successful, it goes to the next flow; if not, it will try three times then go to the S1 flow. It delays for a while then read D15~D19 of station 2. The method is similar to S0 flow. Then go to S2 flow. If the communication is failed, set ON M23. Then it goes to S3 flow. S3 flow will judge the station no, if the no. is less than 4, the station no. will plus 1, offset value plus 10; if not, the station no. will start again from 2.

**Example 2: XINJE PLC writes frequency to two inverters via Modbus.**

Set the first inverter's station no. to 1; set the second inverter's station no. to 2; store the frequency in D1000 and D2000. Communicate with inverter via serial port.

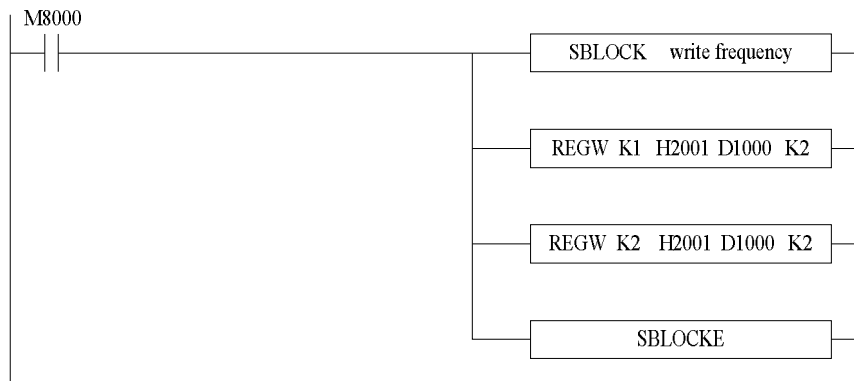

#### Program Description:

Use BLOCK to make the program. The two Modbus instructions will be executed from up to down.

### 12-3. Free Format Communication Example

In this example, we use DH107/DH108 series instruments;

#### 1、Interface Specifications

DH107/DH108 series instruments use asynchronous serial communication interface, the interface level fits RS232C or RS485 standard. The data format is: 1 start bit, 8 data bits, no parity, one/two stop bit. The baud rate can be 1200~ 19200 bits/s.

#### 2、Communication Instruction Format

DH107/108 instruments use Hex data form to represent each instruction code and data;

Read/write instructions:

Read: address code +52H (82) +the para.(to read) code +0+0+CRC parity code

Write: address code +43H (67) + the para.(To write) code +low bytes of the wrote data + high bytes of the wrote data +CRC parity code

The read instruction's CRC parity code is: the para. (to read) code \*256+82+ADDR

ADDR is instrument's address para, the range is 0~100 (pay attention not to add 80H). CRC is the remainder from the addition of the above data (binary 16bits integral). The reminder is 2 bytes; the high byte is behind the low byte;

The write instruction's CRC parity code is: the Para. (To write) code \* 256+67+ the Para. Value (to write) +ADDR

The parameter to write represents with 16 bits binary integral;

No matter to write or read, the instrument should return data as shown below:

The test value PV+ given value SV+ output value MV and alarm status +read/write parameters value +CRC parity code

Among in, PV、SV and the read parameters are all in integral form, each occupies two bytes, MV

---

occupies one byte, the value range is 0~220, alarm status occupies one byte, CRC parity code occupies two bytes, totally 10 bytes.

CRC parity code is the reminder from the result of PV+SV+ (alarm status \*256+MV) + Para. Value +ADDR;

(For details, please refer to AIBUS communication description)

### 3、 Write the program

After power on the PLC, the PLC read the current temperature every 40ms. During this period, the user can write the set temperature.

Data zone definition: buffer area of sending data D10~D19

Buffer area of accepting data D20~D29

Instruction's station number: D30

Read command's value: D31=52 H

Write command's value: D32=43 H

Parameter's code: D33

Temperature setting: D34

CRC parity code: D36

Temperature display: D200, D201

The send data form: 81H 43H 00H c8H 00H 0cH 01H (current temperature display)

Communication parameters setting: baud rate: 9600, 8 data bits, 2 stop bits, no parity

Set FD8220=255; FD8221=5

(The hardware and software must be V2.4 or above)

Ladder:

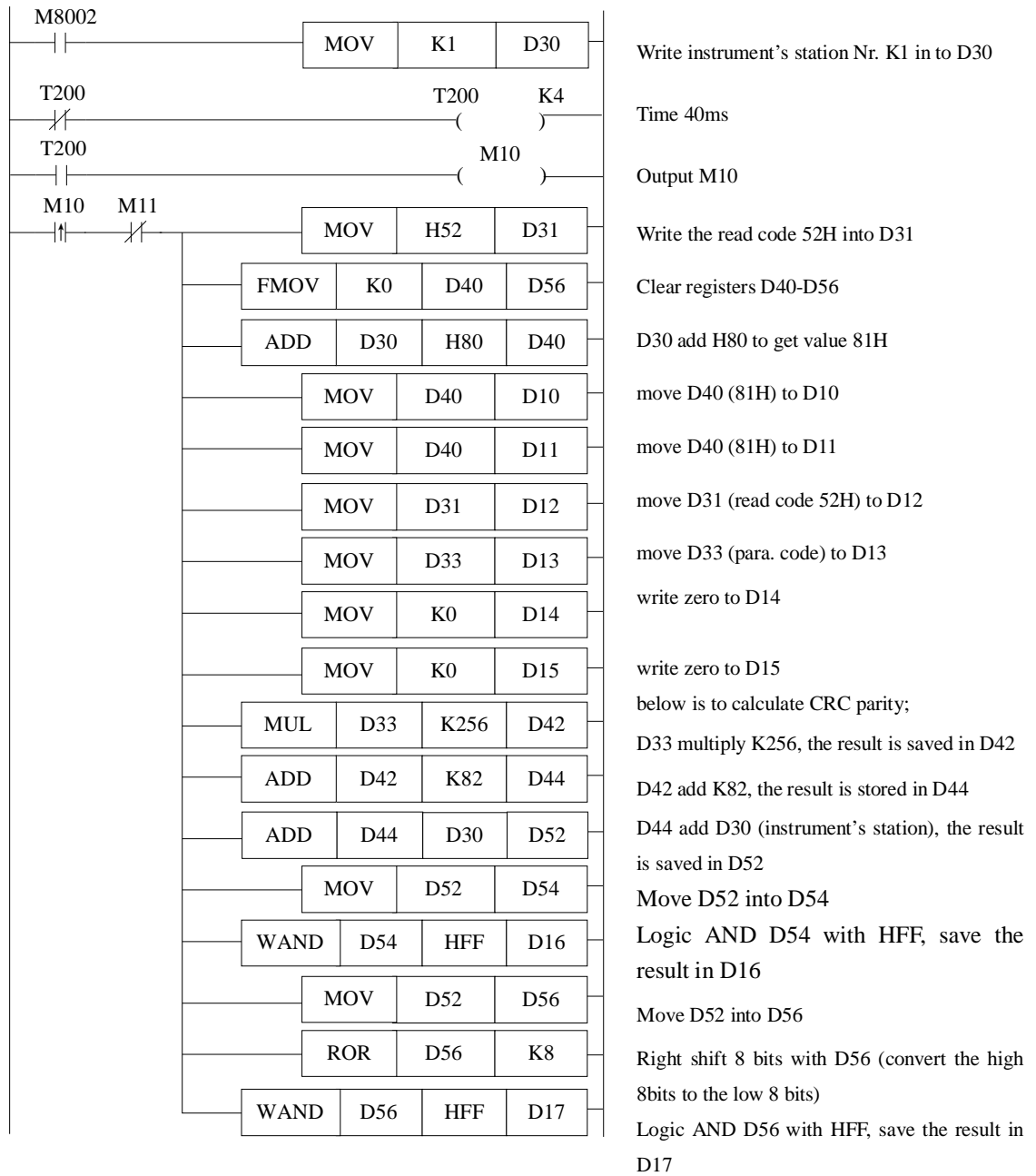

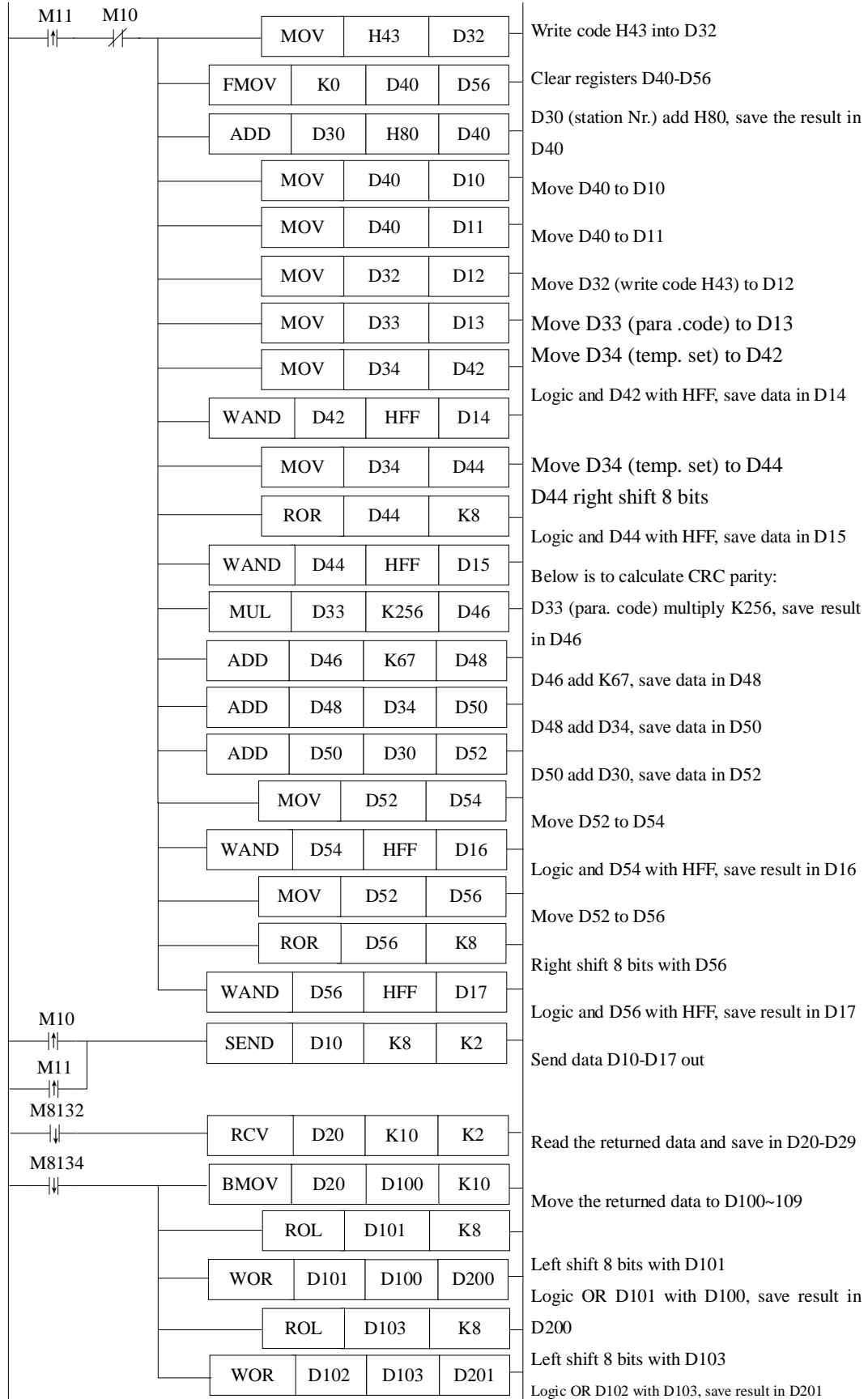

---

Program Description:

The above program is written according to DH instrument's communication protocol, the soft component's functions are listed below:

Relationship of sent (SEND) data string and registers:

|       | D10          | D11          | D12            | D13             | D14                           | D15                            | D16           | D17            |
|-------|--------------|--------------|----------------|-----------------|-------------------------------|--------------------------------|---------------|----------------|
| Read  | Address code | Address code | Read code 52H  | Parameters code | 0                             | 0                              | CRC low bytes | CRC high bytes |
| Write | Address code | Address code | Write code 42H | Parameters code | low bytes of the written data | high bytes of the written data | CRC low bytes | CRC high bytes |

Relationship of received (RCV) data (data returned by the instrument) and the registers:

| D20          | D21           | D22          | D23           | D24          | D25          | D26                  | D27                   | D28           | D29            |
|--------------|---------------|--------------|---------------|--------------|--------------|----------------------|-----------------------|---------------|----------------|
| PV low bytes | PV high bytes | SV low bytes | SV high bytes | Output value | Alarm status | Read/write low bytes | Read/write high bytes | CRC low bytes | CRC high bytes |

So, if write data string according to the communication objects' protocol, use SEND and RCV commands from free format communication, user will get the communication with the objects.

## **Appendix 1 Special soft device list**

---

Here we mainly introduce the functions of special soft device, data register and FlashROM, and introduce the address of expansion. Users can scan fast.

Appendix 1-1. Special Auxiliary Relay List

Appendix 1-2. Special Data Register List

Appendix 1-3. Special Module Address List

Appendix 1-4. Special Flash Register List

**Appendix 1-1. Special Auxiliary Relay List**

**PC Status (M8000-M8003)**

| ID    | Function                       | Description |  |
|-------|--------------------------------|-------------|--|
| M8000 | Normally ON coil when running  |             | M8000 keeps being ON status when PLC is running  |
| M8001 | Normally OFF coil when running |             | M8001 keeps being OFF status when PLC is running |
| M8002 | Initial positive pulse coil    |             | M8002 be ON in first scan cycle                  |
| M8003 | Initial negative pulse coil    |             | M8003 be OFF in first scan cycle                 |

**Clock (M8011-M8014)**

| ID    | Function                      | Description |
|-------|-------------------------------|-------------|
| M8011 | Shake with the cycle of 10ms  |             |
| M8012 | Shake with the cycle of 100ms |             |
| M8013 | Shake with the cycle of 10sec |             |
| M8014 | Shake with the cycle of 1min  |             |

**Flag (M8020-M8029)**

| ID    | Function  | Description   |
|-------|-----------|---|
| M8020 | Zero      | The plus/minus operation result is 0  |
| M8021 | Borrow    | “borrow” occurs in minus operation  |
| M8022 | Carry     | When carry occurs in plus operation or overflow occurs in bit shift operation |
| M8023 |           |   |
| M8026 | RAMP Mode |   |
| M8029 |           |   |

**PC Mode (M8030-M8038)**

| ID    | Function                     | Description   |
|-------|------------------------------|---|
| M8030 | PLC initializing             |   |
| M8031 | Non-retentive register reset | When driving this M, ON/OFF mapping memory of Y, M, S, TC and the current values of T, C, D are all reset to be 0 |
| M8032 | Retentive register reset     |   |
| M8033 | Registers keep stopping      | When PLC changes from RUN to STOP, leave all content in mapping registers and data registers                      |
| M8034 | All output forbidden         | Set PC's all external contacts to be OFF status   |
| M8038 | Parameter setting            | Set communication parameters flag   |

**Stepping Ladder (M8041-M8046)**

| ID    | Function                   | Description  |
|-------|----------------------------|--|
| M8041 |                            |  |
| M8045 | All output reset forbidden | When shifting the mode, all outputs reset functions are forbidden    |
| M8046 | STL status activate        | When M8047 activating, act when any device of S0~S999 turns to be ON |

**Interruption (M8050-M8059)**

| ID             | Function                        | Description   |
|----------------|---------------------------------|---|
| M8050<br>I000□ | Forbid the input interruption 0 | After executing EI instruction, even the interruption is allowed, but if M acts at this time, the correspond input interruption couldn't act separately<br>E.g.: when M8050 is ON, interrupt I000□ is forbidden |
| M8051<br>I010□ | Forbid the input interruption 1 |   |
| M8052<br>I020□ | Forbid the input interruption 2 |   |
| M8053<br>I030□ | Forbid the input interruption 3 |   |
| M8054<br>I040□ | Forbid the input interruption 4 |   |
| M8055<br>I050□ | Forbid the input interruption 5 |   |
| M8056<br>I40□□ | Forbid the time interruption 0  | After executing EI instruction, even the interruption is allowed, but if M acts at this time, the correspond time interruption couldn't act separately  |
| M8057<br>I41□□ | Forbid the time interruption 1  |   |
| M8058<br>I42□□ | Forbid the time interruption 2  |   |
| M8059          | Forbid the interruption         | Forbid all interruption   |

**Error Testing (M8067-M8072)**

| ID    | Function           | Description                                     |
|-------|--------------------|---|
| M8067 | Operation error    | happen when calculating                         |
| M8070 | Scan time out      |   |
| M8071 | No user program    | Internal codes parity error                     |
| M8072 | User program error | execution codes or configure table parity error |

**Communication (M8120-M8148)**

|      | ID    | Function                      | Description   |
|------|-------|-------------------------------|---|
| COM1 | M8120 |                               |   |
|      | M8121 | Waiting to send via RS232     |   |
|      | M8122 | “sending by RS232” flag       |   |
|      | M8123 | “RS232 receiving finish” flag |   |
|      | M8124 | RS232 receiving flag          |   |
|      | M8125 | “Receive incomplete” flag     | acceptance ends normally, but the accepted data number is less than the required number |
|      | M8126 | Global signal                 |   |
|      | M8127 | “Accept error” flag           |   |
|      | M8128 | “Accept correct” flag         |   |
|      | M8129 |                               |   |
| COM2 | M8130 |                               |   |
|      | M8131 | Waiting to send via RS232     |   |
|      | M8132 | “sending by RS232” flag       |   |
|      | M8133 | “RS232 receiving finish” flag |   |
|      | M8134 | RS232 receiving flag          |   |
|      | M8135 | “Receive incomplete” flag     | acceptance ends normally, but the accepted data number is less than the required number |
|      | M8136 | Global signal                 |   |
|      | M8137 | “Accept error” flag           |   |
|      | M8138 | “Accept correct” flag         |   |
|      | M8139 |                               |   |
| COM3 | M8140 |                               |   |
|      | M8141 | Waiting to send via RS232     |   |
|      | M8142 | “sending by RS232” flag       |   |
|      | M8143 | “RS232 receiving finish” flag |   |
|      | M8144 | RS232 receiving flag          |   |
|      | M8145 | “Receive incomplete” flag     | acceptance ends normally, but the accepted data number is less than the required number |
|      | M8146 | Global signal                 |   |
|      | M8147 | “Accept error” flag           |   |
|      | M8148 | “Accept correct” flag         |   |
|      | M8149 |                               |   |

**“High Speed Counter Interruption Finished” Flag (M8150-M 8169)**

| ID    | Counter ID | Function                           | Description                                |
|-------|------------|------------------------------------|--|
| M8150 | C600       | “Count Interruption Finished” Flag | Set flag ON when count interruption finish |
| M8151 | C602       | “Count Interruption Finished” Flag | Set flag ON when count interruption finish |
| M8152 | C604       | “Count Interruption Finished” Flag | Set flag ON when count interruption finish |
| M8153 | C606       | “Count Interruption Finished” Flag | Set flag ON when count interruption finish |
| M8154 | C608       | “Count Interruption Finished” Flag | Set flag ON when count interruption finish |
| M8155 | C610       | “Count Interruption Finished” Flag | Set flag ON when count interruption finish |
| M8156 | C612       | “Count Interruption Finished” Flag | Set flag ON when count interruption finish |
| M8157 | C614       | “Count Interruption Finished” Flag | Set flag ON when count interruption finish |
| M8158 | C616       | “Count Interruption Finished” Flag | Set flag ON when count interruption finish |
| M8159 | C618       | “Count Interruption Finished” Flag | Set flag ON when count interruption finish |
| M8160 | C620       | “Count Interruption Finished” Flag | Set flag ON when count interruption finish |
| M8161 | C622       | “Count Interruption Finished” Flag | Set flag ON when count interruption finish |
| M8162 | C624       | “Count Interruption Finished” Flag | Set flag ON when count interruption finish |
| M8163 | C626       | “Count Interruption Finished” Flag | Set flag ON when count interruption finish |
| M8164 | C628       | “Count Interruption Finished” Flag | Set flag ON when count interruption finish |
| M8165 | C630       | “Count Interruption Finished” Flag | Set flag ON when count interruption finish |
| M8166 | C632       | “Count Interruption Finished” Flag | Set flag ON when count interruption finish |
| M8167 | C634       | “Count Interruption Finished” Flag | Set flag ON when count interruption finish |
| M8168 | C636       | “Count Interruption Finished” Flag | Set flag ON when count interruption finish |
| M8169 | C638       | “Count Interruption Finished” Flag | Set flag ON when count interruption finish |

**Pulse output (M8170-M8238)**

| ID    | Pulse ID | Function                                 | specification  |
|-------|----------|--|--|
| M8170 | PULSE_1  | “sending pulse” flag                     | Being ON when sending the pulse,                             |
| M8171 |          | overflow flag of “32 bits pulse sending” | When overflow, Flag is on                                    |
| M8172 |          | Direction flag                           | 1 is positive direction, the correspond direction port is on |
| M8173 | PULSE_2  | “sending pulse” flag                     | Being ON when sending the pulse,                             |
| M8174 |          | overflow flag of “32 bits pulse sending” | When overflow, Flag is on                                    |
| M8175 |          | Direction flag                           | 1 is positive direction, the correspond direction port is on |

|       |         |  |  |
|-------|---------|--|--|
| M8176 | PULSE_3 | “sending pulse” flag                     | Being ON when sending the pulse,                             |
| M8177 |         | overflow flag of “32 bits pulse sending” | When overflow, Flag is on                                    |
| M8178 |         | Direction flag                           | 1 is positive direction, the correspond direction port is on |
| M8179 | PULSE_4 | “sending pulse” flag                     | Being ON when sending the pulse,                             |
| M8180 |         | overflow flag of “32 bits pulse sending” | When overflow, Flag is on                                    |
| M8181 |         | Direction flag                           | 1 is positive direction, the correspond direction port is on |

**Absolute, relative bit:**

| ID    | function                                     | specification                              |         |
|-------|--|--|---------|
| M8190 | C600 (24 segments)                           | <b>1</b> is absolute, <b>0</b> is relative |         |
| M8191 | C602 (24 segments)                           | <b>1</b> is absolute, <b>0</b> is relative |         |
| M8192 | C604 (24 segments)                           | <b>1</b> is absolute, <b>0</b> is relative |         |
| M8193 | C606 (24 segments)                           | <b>1</b> is absolute, <b>0</b> is relative |         |
| M8194 | C608 (24 segments)                           | <b>1</b> is absolute, <b>0</b> is relative |         |
| M8195 | C610 (24 segments)                           | .....                                      |         |
| M8196 | C612 (24 segments)                           |  |         |
| M8197 | C614 (24 segments)                           |  |         |
| M8198 | C616 (24 segments)                           |  |         |
| M8199 | C618 (24 segments)                           |  |         |
| M8200 | C620 (24 segments)                           |  |         |
| M8201 | C622 (24 segments)                           |  |         |
| M8202 | C624 (24 segments)                           |  |         |
| M8203 | C626 (24 segments)                           |  |         |
| M8204 | C628 (24 segments)                           |  |         |
| M8205 | C630 (24 segments)                           |  |         |
| M8206 | C632 (24 segments)                           |  |         |
| M8207 | C634 (24 segments)                           |  |         |
| M8208 | C636 (24 segments)                           |  |         |
| M8209 | C638 (24 segments)                           |  |         |
| M8210 | Pulse alarm flag (frequency change suddenly) | <b>1</b> is alarm, <b>0</b> is correct     | PULSE_1 |
| M8211 | Neglect the alarm or not                     | When flag is 1, stop sending alarm         | PULSE_1 |
| M8212 | Pulse alarm flag (frequency change suddenly) | <b>1</b> is alarm, <b>0</b> is correct     | PULSE_2 |
| M8213 | Neglect the alarm or not                     | When flag is 1, stop sending alarm         | PULSE_2 |
| M8214 | Pulse alarm flag (frequency change suddenly) | <b>1</b> is alarm, <b>0</b> is correct     | PULSE_3 |
| M8215 | Neglect the alarm or not                     | When flag is 1, stop sending alarm         | PULSE_3 |

|       |  |  |         |
|-------|--|--|---------|
| M8216 | Pulse alarm flag (frequency change suddenly) | <b>1</b> is alarm, <b>0</b> is correct | PULSE_4 |
| M8217 | Neglect the alarm or not                     | When flag is 1, stop sending alarm     | PULSE_4 |
| M8218 | Pulse alarm flag (frequency change suddenly) | <b>1</b> is alarm, <b>0</b> is correct | PULSE_5 |
| M8219 | Neglect the alarm or not                     | When flag is 1, stop sending alarm     | PULSE_5 |

**Positive/negative count**

| ID    | Counter Nr. | Function                          | Specification  |
|-------|-------------|-----------------------------------|--|
| M8238 | C300~C498   | Positive/negative counter control | <b>0</b> is increment counter, <b>1</b> is decrement counter, default is 0 |

**24 segments HSC interruption loop (M8270~M8289)**

| ID    | Counter ID                               | Specification  |
|-------|--|--|
| M8270 | 24 segments HSC interruption loop (C600) | if set it to be 1, then loop executing the interruption; or else execute only one time interruption; |
| M8271 | 24 segments HSC interruption loop (C602) |  |
| M8272 | 24 segments HSC interruption loop (C604) |  |
| M8273 | 24 segments HSC interruption loop (C606) |  |
| M8274 | 24 segments HSC interruption loop (C608) |  |
| M8275 | 24 segments HSC interruption loop (C610) |  |
| M8276 | 24 segments HSC interruption loop (C612) |  |
| M8277 | 24 segments HSC interruption loop (C614) |  |
| ..... | .....                                    |  |
| M8279 | 24 segments HSC interruption loop (C618) |  |
| M8280 | 24 segments HSC interruption loop (C620) | if set it to be 1, then loop executing the interruption; or else execute only one time interruption; |
| M8281 | 24 segments HSC interruption loop (C622) |  |
| ..... | .....                                    |  |
| M8284 | 24 segments HSC interruption loop (C628) |  |
| M8285 | 24 segments HSC interruption loop        | if set it to be 1, then loop   |

|       |   |   |  |
|-------|---|---|--|
|       | (C630)                                      | executing the interruption; or<br>else execute only one time<br>interruption; |  |
| ..... | .....                                       |   |  |
| M8289 | 24 segments HSC interruption loop<br>(C638) |   |  |

**Read & Write the Expansions (M8340~M8341)**

| ID    | Function   | Specification |
|-------|--|---------------|
| M8340 | Read the expansion error flag ( <b>read</b> instruction)   |               |
| M8341 | Write the expansion error flag ( <b>write</b> instruction) |               |

**BLOCK Execution (M8630~M8730)**

| ID    | Function                 | Specification |
|-------|--------------------------|---------------|
| M8630 |                          |               |
| M8631 | BLOCK1 is running flag   |               |
| M8632 | BLOCK2 is running flag   |               |
| ..... | .....                    | .....         |
| ..... | .....                    | .....         |
| ..... | .....                    | .....         |
| M8730 | BLOCK100 is running flag |               |

## Appendix 1-2. List of special memory and special data register

### Clock (D8010-D8019)

| ID    | Function               | Specification                      |
|-------|------------------------|------------------------------------|
| D8010 | The current scan cycle | Unit:0.1ms                         |
| D8011 | The min. scan time     | Unit:0.1ms                         |
| D8012 | The max. scan time     | Unit:0.1ms                         |
| D8013 | Second (clock)         | 0~59 (BCD code)                    |
| D8014 | minute (clock)         | 0~59 (BCD code)                    |
| D8015 | hour (clock)           | 0~23 (BCD code)                    |
| D8016 | day (clock)            | 0~31 (BCD code)                    |
| D8017 | month (clock)          | 0~12 (BCD code)                    |
| D8018 | year (clock)           | 2000~2099 (BCD code)               |
| D8019 | week (clock)           | 0 (Sunday)~6 (Saturday) (BCD code) |

### Flag (D8021-D8029)

| ID    | Function                           | Specification          |
|-------|------------------------------------|------------------------|
| D8021 | Model                              | Low byte               |
|       | Series number                      | High byte              |
| D8022 | Compatible system's version number | Low byte               |
|       | System's version number            | High byte              |
| D8023 | Compatible model's version number  | Low byte               |
|       | Model's version number             | High byte              |
| D8024 | Model's information                | Max 5 characters +“\0” |
| D8025 |                                    |                        |
| D8026 |                                    |                        |
| D8027 |                                    |                        |
| D8028 | Suitable program software version  |                        |
| D8029 |                                    |                        |

**Error check (D8067-D8098)**

| ID    | Function                   | Specification            |
|-------|----------------------------|--------------------------|
| D8067 | Operation error code's Nr. | The error of divide zero |
| D8068 | lock the Nr. of error code |                          |
| D8069 |                            |                          |
| D8070 | exceeded scan time         | Unit 1ms                 |
| D8074 | Nr. of offset registers D  |                          |
| D8097 |                            |                          |
| D8098 |                            |                          |

**Communication (D8120-D8149)**

|       | ID    | Function   | specification  |
|-------|-------|--|--|
| Com 1 | D8120 |  |  |
|       | D8121 |  |  |
|       | D8122 | the left data RS232 should send  |  |
|       | D8123 | Data number RS232 received   |  |
|       | D8126 |  |  |
|       | D8127 | Communication error code   | 7: hardware error<br>8: CRC Parity error<br>9: station number error<br>10: no start code<br>11: no end code<br>12: communication time out                      |
|       | D8128 | Modbus communication error<br>(the replied message from slaves<br>when the master send errors) | 0: correct<br>1: don't support function ID<br>2: address error (overrun address)<br>3: Data error (the number of data)<br>8: saving data error (rewrite Flash) |
|       | D8129 |  |  |
| Com2  | D8130 |  |  |
|       | D8131 |  |  |
|       | D8132 | the left data RS232 should send  |  |
|       | D8133 | Data number RS232 received   |  |
|       | D8136 |  |  |

|       |       |  |  |
|-------|-------|--|--|
|       | D8137 | Communication error code   | 7: hardware error<br>8: CRC check error<br>9: station number error<br>10: no start sign<br>11: no end sign<br>12: communication time out                         |
|       | D8138 | Modbus communication error<br>(the replied message from slaves<br>when the master send errors) | 0: correct<br>1: don't support function ID<br>2: address error(overrun address)<br>3: Data error ( the number of data)<br>8: saving data error ( rewrite Flash ) |
|       | D8139 |  |  |
| Com 3 | D8140 |  |  |
|       | D8141 |  |  |
|       | D8142 | the left data RS232 should send  |  |
|       | D8143 | Data number RS232 received   |  |
|       | D8146 |  |  |
|       | D8147 | Communication error code   | 7: hardware error<br>8: CRC check error<br>9: station number error<br>10: no start sign<br>11: no end sign<br>12: communication time out                         |
|       | D8148 | Modbus communication error<br>(the replied message from slaves<br>when the master send errors) | 0: correct<br>1: don't support function ID<br>2: address error(overrun address)<br>3: Data error ( the number of data)<br>8: saving data error ( rewrite Flash ) |
|       | D8149 |  |  |

**HSC Interruption Station (D8150-D8169)**

| ID    | Counter ID | function                                   | specification |
|-------|------------|--|---------------|
| D8150 | C600       | The current segment ( <b>No.n</b> segment) |               |
| D8151 | C602       | The current segment                        |               |
| D8152 | C604       | The current segment                        |               |
| D8153 | C606       | The current segment                        |               |
| D8154 | C608       | The current segment                        |               |
| D8155 | C610       | The current segment                        |               |
| D8156 | C612       | The current segment                        |               |
| D8157 | C614       | The current segment                        |               |

|       |      |                     |  |
|-------|------|---------------------|--|
| D8158 | C616 | The current segment |  |
| D8159 | C618 | The current segment |  |
| D8160 | C620 | The current segment |  |
| D8161 | C622 | The current segment |  |
| D8162 | C624 | The current segment |  |
| D8163 | C626 | The current segment |  |
| D8164 | C628 | The current segment |  |
| D8165 | C630 | The current segment |  |
| D8166 | C632 | The current segment |  |
| D8167 | C634 | The current segment |  |
| D8168 | C636 | The current segment |  |
| D8169 | C638 | The current segment |  |

**Pulse output (D8170-D8220)**

| ID    | Pulse ID | function   | specification                       |
|-------|----------|--|-------------------------------------|
| D8170 | PULSE_1  | The low 16 bits of accumulated pulse number                      |                                     |
| D8171 |          | The high 16 bits of accumulated pulse number                     |                                     |
| D8172 |          | The current segment (means Nr.n segment)                         |                                     |
| D8173 | PULSE_2  | The low 16 bits of accumulated pulse number                      |                                     |
| D8174 |          | The high 16 bits of accumulated pulse number                     |                                     |
| D8175 |          | The current segment (means Nr.n segment)                         |                                     |
| D8176 | PULSE_3  | The low 16 bits of accumulated pulse number                      | Only XC5-32RT-E<br>(4PLS) model has |
| D8177 |          | The high 16 bits of accumulated pulse number                     |                                     |
| D8178 |          | The current segment (means Nr.n segment)                         |                                     |
| D8179 | PULSE_4  | The low 16 bits of accumulated pulse number                      |                                     |
| D8180 |          | The high 16 bits of accumulated pulse number                     |                                     |
| D8181 |          | The current segment (means Nr.n segment)                         |                                     |
| D8190 | PULSE_1  | The low 16 bits of the current accumulated current pulse number  |                                     |
| D8191 |          | The high 16 bits of the current accumulated current pulse number |                                     |
| D8192 | PULSE_2  | The low 16 bits of the current accumulated current pulse number  |                                     |
| D8193 |          | The high 16 bits of the current accumulated                      |                                     |

|       |         |  |                                  |
|-------|---------|--|----------------------------------|
|       |         | current pulse number   |                                  |
| D8194 | PULSE_3 | The low 16 bits of the current accumulated current pulse number  | Only XC5-32RT-E (4PLS) model has |
| D8195 |         | The high 16 bits of the current accumulated current pulse number |                                  |
| D8196 | PULSE_4 | The low 16 bits of the current accumulated current pulse number  |                                  |
| D8197 |         | The high 16 bits of the current accumulated current pulse number |                                  |

| ID    | Pulse ID                    | Function  | Description |
|-------|-----------------------------|---|-------------|
| D8210 | PULSE_1                     | Error segment number  | PULSE_1     |
|       |                             |   |             |
| D8212 | PULSE_2                     | Error segment number  | PULSE_2     |
|       |                             |   |             |
| D8214 | PULSE_3                     | Error segment number  | PULSE_3     |
|       |                             |   |             |
| D8216 | PULSE_4                     | Error segment number  | PULSE_4     |
|       |                             |   |             |
| D8218 | PULSE_5                     | Error segment number  | PULSE_5     |
|       |                             |   |             |
| D8220 | Frequency Testing Precision | indicate the bit Nr. Behind the decimal dot, <b>1</b> means <b>*10</b> , <b>2</b> means <b>*100</b> |             |

**Absolute Positioning/Relative Positioning/the Origin Return (D8230-D8239)**

| ID    | Pulse   | Function   | Description |
|-------|---------|--|-------------|
| D8230 | PULSE_1 | Rising time of the absolute/relation position instruction (Y0) |             |
| D8231 |         | Falling time of the origin return instruction (Y0)             |             |
| D8232 | PULSE_2 | Rising time of the absolute/relation position instruction (Y1) |             |
| D8233 |         | Falling time of the origin return instruction (Y1)             |             |
| D8234 | PULSE_3 | Rising time of the absolute/relation position instruction (Y2) |             |
| D8235 |         | Falling time of the origin return instruction (Y2)             |             |
| D8236 | PULSE_4 | Rising time of the absolute/relation position instruction (Y3) |             |
| D8237 |         | Falling time of the origin return instruction (Y3)             |             |
| D8238 | PULSE_5 | Rising time of the absolute/relation position instruction      |             |
| D8239 |         | Falling time of the origin return instruction                  |             |

**Read/Write the Expansion (D8315-D8316)**

| ID    | Function                         | Description |
|-------|----------------------------------|-------------|
| D8315 | Read the expansion's error type  |             |
| D8316 | Write the expansion's error type |             |

**Sequential Function Block (D8630-D8730)**

| ID    | Function   | Description                                       |
|-------|--|---|
| D8630 |  |   |
| D8631 | The current executing instruction of <b>BLOCK1</b>   | The value is used when <b>BLOCK</b> is monitoring |
| D8632 | The current executing instruction of <b>BLOCK2</b>   | The value is used when <b>BLOCK</b> is monitoring |
| ..... | .....  | .....   |
| ..... | .....  | .....   |
| ..... | .....  | .....   |
| D8730 | The current executing instruction of <b>BLOCK100</b> | The value is used when <b>BLOCK</b> is monitoring |

**Error information of the Expansions (D8600-D8627)**

| ID    | Function                          | specification  | Expansion ID |
|-------|-----------------------------------|--|--------------|
| D8600 | Read the expansion's error times  |  | Expansion 1  |
| D8601 | Read the expansion's error        | <ol style="list-style-type: none"> <li>1. expansion's CRC parity error</li> <li>2. expansion's address error</li> <li>3. expansion's accepted data length error</li> <li>4. expansion's accept buffer zone overflow</li> <li>5. expansion's timeout error</li> <li>6. CRC parity error when PLC is accepting data</li> <li>7. unknown error</li> </ol> |              |
| D8602 | write the expansion's error times |  |              |
| D8603 | write the expansion's error       | .....  |              |

|       |                                   |       |             |
|-------|-----------------------------------|-------|-------------|
| D8604 | Read the expansion's times        |       | Expansion 2 |
| D8605 | Read the expansion's error        | ..... |             |
| D8606 | write the expansion's error times |       |             |
| D8607 | write the expansion's error       | ..... |             |
| D8608 | Read the expansion's times        |       | Expansion 3 |
| D8609 | Read the expansion's error        | ..... |             |
| D8610 | write the expansion's error times |       |             |
| D8611 | write the expansion's error       | ..... | Expansion 4 |
| D8612 | Read the expansion's times        |       |             |
| D8613 | Read the expansion's error        | ..... |             |
| D8614 | write the expansion's error times |       |             |
| D8615 | write the expansion's error       | ..... | Expansion 7 |
| ..... | .....                             | ..... |             |
| ..... | .....                             | ..... |             |
| D8624 | Read the expansion's times        |       |             |
| D8625 | Read the expansion's error        | ..... |             |
| D8626 | write the expansion's error times |       |             |
| D8627 | write the expansion's error       | ..... |             |

**Appendix 1-3. ID List of the Expansions**

Take the first expansion module as the example:

| Channel           | AD signal | DA signal | PID Output value | PID run/stop bit | Set value | PID parameter: Kp, Ki, Kd, control range Diff, Death range death           |
|-------------------|-----------|-----------|------------------|------------------|-----------|--|
| <b>XC-E8AD</b>    |           |           |                  |                  |           |  |
| 0CH               | ID100     | -         | ID108            | Y100             | QD100     | Kp----QD108<br>Ki-----QD109<br>Kd----QD110<br>Diff---QD111<br>Death--QD112 |
| 1CH               | ID101     | -         | ID109            | Y101             | QD101     |  |
| 2CH               | ID102     | -         | ID110            | Y102             | QD102     |  |
| 3CH               | ID103     | -         | ID111            | Y103             | QD103     |  |
| 4CH               | ID104     | -         | ID112            | Y104             | QD104     |  |
| 5CH               | ID105     | -         | ID113            | Y105             | QD105     |  |
| 6CH               | ID106     | -         | ID114            | Y106             | QD106     |  |
| 7CH               | ID107     | -         | ID115            | Y107             | QD107     |  |
| <b>XC-E4AD2DA</b> |           |           |                  |                  |           |  |
| 0CH               | ID100     | -         | ID104            | Y100             | QD102     | Kp----QD106<br>Ki-----QD107<br>Kd----QD108<br>Diff---QD109<br>Death--QD110 |
| 1CH               | ID101     | -         | ID105            | Y101             | QD103     |  |
| 2CH               | ID102     | -         | ID106            | Y102             | QD104     |  |
| 3CH               | ID103     | -         | ID107            | Y103             | QD105     |  |
| 0CH               | -         | QD100     | -                | -                | -         |  |
| 1CH               | -         | QD101     | -                | -                | -         |  |
| <b>XC-E4AD</b>    |           |           |                  |                  |           |  |
| 0CH               | ID100     | -         | ID104            | Y100             | QD100     | Kp----QD104<br>Ki-----QD105<br>Kd----QD106                                 |
| 1CH               | ID101     | -         | ID105            | Y101             | QD101     |  |
| 2CH               | ID102     | -         | ID106            | Y102             | QD102     |  |

|     |       |   |       |      |       |                              |
|-----|-------|---|-------|------|-------|------------------------------|
| 3CH | ID103 | - | ID107 | Y103 | QD103 | Diff---QD107<br>Death--QD108 |
|-----|-------|---|-------|------|-------|------------------------------|

**XC-E4DA**

| CH Nr. | Exp. 1 | Exp. 2 | Exp. 3 | Exp. 4 | Exp. 5 | Exp. 6 | Exp. 7 |
|--------|--------|--------|--------|--------|--------|--------|--------|
| 0CH    | QD100  | QD200  | QD300  | QD400  | QD500  | QD600  | QD700  |
| 1CH    | QD101  | QD201  | QD301  | QD401  | QD501  | QD601  | QD701  |
| 2CH    | QD102  | QD202  | QD302  | QD402  | QD502  | QD602  | QD702  |
| 3CH    | QD103  | QD203  | QD303  | QD403  | QD503  | QD603  | QD703  |

**XC-E2DA**

| CH Nr. | Exp. 1 | Exp. 2 | Exp. 3 | Exp. 4 | Exp. 5 | Exp. 6 | Exp. 7 |
|--------|--------|--------|--------|--------|--------|--------|--------|
| 0CH    | QD100  | QD200  | QD300  | QD400  | QD500  | QD600  | QD700  |
| 1CH    | QD101  | QD201  | QD301  | QD401  | QD501  | QD601  | QD701  |

**XC-E6PT-P/ XC-E6TC-P**

| CH Nr. | Current temp. | Set temp. | PID run/stop bit | The first 3CH PID value                            | The last 3CH PID value                             |
|--------|---------------|-----------|------------------|--|--|
| 0CH    | ID100         | QD100     | Y100             | Kp: QD106<br>Ki: QD107<br>Kd: QD108<br>Diff: QD109 | Kp: QD110<br>Ki: QD111<br>Kd: QD112<br>Diff: QD113 |
| 1CH    | ID101         | QD101     | Y101             |  |  |
| 2CH    | ID102         | QD102     | Y102             |  |  |
| 3CH    | ID103         | QD103     | Y103             |  |  |
| 4CH    | ID104         | QD104     | Y104             |  |  |
| 5CH    | ID105         | QD105     | Y105             |  |  |

**XC-E6TCA-P**

| RELATIVE PARAMETERS   | COMMENTS AND DESCRIPTIONS |       |       |       |       |
|---|---------------------------|-------|-------|-------|-------|
|   | CH                        | Ch0   | Ch1   | ..... | Ch5   |
| Display temperature<br>(unit: 0.1°C)                                | module 1                  | ID100 | ID101 | ID10× | ID105 |
| PID output<br>(X input which returns to main unit)                  | module 1                  | X100  | X101  | X10×  | X105  |
| Thermocouple's connecting status<br>(0 is connect, 1 is disconnect) | module 1                  | X110  | X111  | X11×  | X115  |

|  |  |      |      |      |      |
|--|--|------|------|------|------|
| PID auto tune error bit (0 is normal, 1 is parameters error) | module 1   | X120 | X121 | X12× | X125 |
| Enable channel's signal                                      | module 1   | Y100 | Y101 | Y10× | Y105 |
| Auto tune PID control bit                                    | Auto tune activate signal, enter auto tune stage if being set to be 1; when auto turn finish, PID parameters and temperature control cycle value are refreshed, reset this bit automatically.<br>Users can also read its status; 1 represents auto tune processing; 0 represents no auto tune or auto tune finished  |      |      |      |      |
| PID output value (operation value)                           | Digital output value range: 0~4095<br>If PID output is analogue control (like steam valve open scale or thyistor ON angle), transfer this value to the analogue output module to realize the control requirements  |      |      |      |      |
| PID parameters (P、I、D)                                       | Via PID auto tune to get the best parameters;<br>If the current PID control can't fulfill the control requirements, users can also write the PID parameters according to experience. Modules carry on PID control according to the set PID parameters.   |      |      |      |      |
| PID operation range (Diff) (unit: 0.1℃)                      | PID operation activates between $\pm$ Diff range. In real temperature control environments, if the temperature is lower than $T_{\text{set temp.}} - T_{\text{Diff}}$ , PID output the max value; if the temperature is higher than $T_{\text{set temp.}} + T_{\text{Diff}}$ , PID output the mini value;  |      |      |      |      |
| Temperature difference $\delta$ (unit: 0.1℃)                 | (sample temperature+ Temperature difference $\delta$ )/10=display temperature value. Then temperature display value can equal or close to the real temperature value. This parameter has sign (negative or positive). Unit is 0.1℃, the default value is 0.  |      |      |      |      |
| The set temperature value(unit: 0.1℃)                        | Control system's target temperature value. The range is 0~1000℃, the precision is 0.1℃.  |      |      |      |      |
| Temperature control cycle (unit: 0.1s)                       | Control cycle's range is 0.5s~200s, the minimum precision is 0.1s. the write value is the real temperature control cycle multiply 10. i.e. 0.5s control cycle should write 5, 200s control cycle should write 2000.  |      |      |      |      |
| Adjust environment temperature value (unit: 0.1℃)            | If users think the environment temperature is different with the display temperature, he can write in the known temperature value. At the moment of value written in, calculate the temperature difference $\delta$ and save.<br>Calculate the temperature difference value $\delta$ =adjust environment temperature value—sample temperature value. Unit: 0.1℃.<br>E.g.: under heat balance status, user test the environmental temperature as 60.0℃ with mercurial thermometer, the display temperature is 55.0℃ (correspond sample temperature is 550), temperature difference $\delta$ =0. at this time, users write this parameters with 600, temperature difference $\delta$ is re-calculated to be 50 (5℃), then the display temperature = (sample temperature+temperature difference $\delta$ ) /10 =60℃。<br>**Note: when users write the adjust temperature value, make sure that the temperature is same with the environment temperature value. This value is very important, once it's wrong, temperature difference $\delta$ will be wrong, then effect the display temperature |      |      |      |      |
| Auto tune output value                                       | The output when auto tune, use % as the unit, 100 represents 100% of full scale  |      |      |      |      |

|   |
|---|
| output. 80 represents 80% of full scale output. |
|---|

**XC-E3AD4PT2DA**

| CH Nr. | AD signal | PID output value | PID run/stop bit | Set value | PID parameters: <b>Kp</b> , <b>Ki</b> , <b>Kd</b> , control range <b>Diff</b> , death range <b>Death</b> |
|--------|-----------|------------------|------------------|-----------|--|
| 0CH    | ID100     | ID107            | Y100             | QD102     |  |
| 1CH    | ID101     | ID108            | Y101             | QD103     |  |
| 2CH    | ID102     | ID109            | Y102             | QD104     |  |
| CH Nr. | PT signal | PID output value | PID run/stop bit | Set value |  |
| 3CH    | ID103     | ID110            | Y103             | QD105     |  |
| 4CH    | ID104     | ID111            | Y104             | QD106     |  |
| 5CH    | ID105     | ID112            | Y105             | QD107     |  |
| 6CH    | ID106     | ID113            | Y106             | QD108     |  |
|        |           |                  |                  |           | Kp----- QD109<br>Ki----- QD110<br>Kd----- QD111<br>Diff----- QD112<br>Death---- QD113                    |
| CH Nr. | DA signal | -                | -                | -         |  |
| 0CH    | QD100     | -                | -                | -         |  |
| 1CH    | QD101     | -                | -                | -         |  |

**XC-E2AD2PT2DA**

| RELATIVE PARAMETERS   | COMMENTS AND DESCRIPTIONS |             |             |       |       |
|---|---------------------------|-------------|-------------|-------|-------|
|   | CH                        | PT0 (0.01℃) | PT1 (0.01℃) | AD0   | AD1   |
| Display temperature<br>(unit: 0.1℃)                             | module 1                  | ID100       | ID101       | ID102 | ID103 |
| PID output<br>(X input which returns to main unit)              | module 1                  | X100        | X101        | X102  | X103  |
| Connecting status<br>(0 is connect, 1 is disconnect)            | module 1                  | X110        | X111        | X112  | X113  |
| PID auto tune error bit<br>(0 is normal, 1 is parameters error) | module 1                  | X120        | X121        | X122  | X123  |

| Enable channel's signal                      | module 1   | Y100 | Y101 | Y102 | Y103 |
|--|--|------|------|------|------|
| Auto tune PID control bit                    | Auto tune activate signal, enter auto tune stage if being set to be 1; when auto turn finish, PID parameters and temperature control cycle value are refreshed, reset this bit automatically.<br>Users can also read its status; 1 represents auto tune processing; 0 represents no auto tune or auto tune finished  |      |      |      |      |
| PID output value (operation value)           | Digital output value range: 0~4095<br>If PID output is analogue control (like steam valve open scale or thyistor ON angle), transfer this value to the analogue output module to realize the control requirements  |      |      |      |      |
| PID parameters (P、I、D)                       | Via PID auto tune to get the best parameters;<br>If the current PID control can't fulfill the control requirements, users can also write the PID parameters according to experience. Modules carry on PID control according to the set PID parameters.   |      |      |      |      |
| PID operation range (Diff) (unit: 0.1℃)      | PID operation activates between $\pm$ Diff range. In real temperature control environments, if the temperature is lower than $T_{set\ temp.} - T_{Diff}$ , PID output the max value; if the temperature is higher than $T_{set\ temp.} + T_{Diff}$ , PID output the mini value;  |      |      |      |      |
| Temperature difference $\delta$ (unit: 0.1℃) | (sample temperature+ Temperature difference $\delta$ )/10=display temperature value. Then temperature display value can equal or close to the real temperature value. This parameter has sign (negative or positive). Unit is 0.1℃, the default value is 0.  |      |      |      |      |
| The set temperature value(unit: 0.1℃)        | Control system's target temperature value. The range is 0~1000℃, the precision is 0.1℃.  |      |      |      |      |
| Temperature control cycle (unit: 0.1s)       | Control cycle's range is 0.5s~200s, the minimum precision is 0.1s. the write value is the real temperature control cycle multiply 10. i.e. 0.5s control cycle should write 5, 200s control cycle should write 2000.  |      |      |      |      |
| Real value (unit: 0.1℃)                      | <p>If users think the environment temperature is different with the display temperature, he can write in the known temperature value. At the moment of value written in, calculate the temperature difference <math>\delta</math> and save.</p> <p>Calculate the temperature difference value <math>\delta</math>=adjust environment temperature value—sample temperature value. Unit: 0.1℃.</p> <p>E.g.: under heat balance status, user test the environmental temperature as 60.0℃ with mercurial thermometer, the display temperature is 55.0℃ (correspond sample temperature is 550), temperature difference <math>\delta</math>=0. at this time, users write this parameters with 600, temperature difference <math>\delta</math> is re-calculated to be 50 (5℃), then the display temperature = (sample temperature + temperature difference <math>\delta</math>) /10 =60℃.</p> <p>**Note: when users write the adjust temperature value, make sure that the temperature is same with the environment temperature value. This value is very important, once it's wrong, temperature difference <math>\delta</math> will be wrong, then effect the display temperature</p> |      |      |      |      |
| Auto tune output value                       | The output when auto tune, use % as the unit, 100 represents 100% of full scale output. 80 represents 80% of full scale output.  |      |      |      |      |

## Appendix 1-4. Special Flash Register List

### 1、 I filter

| ID     | Function                    | Initial Value | Description |
|--------|-----------------------------|---------------|-------------|
| FD8000 | input filter time of X port | 10            | Unit: ms    |
| FD8002 |                             | 0             |             |
| FD8003 |                             | 0             |             |
| .....  |                             | 0             |             |
| FD8009 |                             | 0             |             |

### 2、 I mapping

| ID     | Function                               | Initial value | Description                                   |
|--------|--|---------------|---|
| FD8010 | <b>X00</b> corresponds with <b>I**</b> | 0             | X0 corresponds with number of input image I** |
| FD8011 | <b>X01</b> corresponds with <b>I**</b> | 1             | Initial values are all decimal                |
| FD8012 | <b>X02</b> corresponds with <b>I**</b> | 2             |   |
| .....  | .....                                  |               |   |
| FD8073 | <b>X77</b> corresponds with <b>I**</b> | 63            |   |

### 3、 O mapping

| ID     | Function                               | Initial value | Description  |
|--------|--|---------------|--|
| FD8074 | <b>Y00</b> corresponds with <b>I**</b> | 0             | Y0 corresponds with the number of output image O** |
| FD8075 | <b>Y01</b> corresponds with <b>I**</b> | 1             | Initial value are all decimal                      |
| FD8076 | <b>Y02</b> corresponds with <b>I**</b> | 2             |  |
| .....  | .....                                  |               |  |
| FD8137 | <b>Y77</b> corresponds with <b>I**</b> | 63            |  |

### 4、 I property

| ID     | function     | Initial value | Description                                  |
|--------|--------------|---------------|--|
| FD8138 | X00 property | all be 0      | 0: positive logic;<br>others: negative logic |
| FD8139 | X01 property |               |  |
| FD8140 | X02 property |               |  |
| .....  | .....        |               |  |
| FD8201 | X77 property |               |  |

### 5、 power-off retentive area of soft components

|                   | Soft component | FD REGISTER | FUNCTION                                | Default value | Power-off retentive range |
|-------------------|----------------|-------------|---|---------------|---------------------------|
| <b>XC1 series</b> | D              | FD8202      | Start tag of D power off retentive area | 100           | D100~D149                 |
|                   | M              | FD8203      | Start tag of M power off                | 200           | M200~M319                 |

|                   |    |        |  |      |             |
|-------------------|----|--------|--|------|-------------|
|                   |    |        | retentive area                           |      |             |
|                   | T  | FD8204 | Start tag of T power off retentive area  | 640  | -           |
|                   | C  | FD8205 | Start tag of C power off retentive area  | 320  | C320~C631   |
|                   | S  | FD8206 | Start tag of S power off retentive area  | 512  | -           |
| <b>XC2 series</b> | D  | FD8202 | Start tag of D power off retentive area  | 4000 | D4000~D4999 |
|                   | M  | FD8203 | Start tag of M power off retentive area  | 3000 | M3000~M7999 |
|                   | T  | FD8204 | Start tag of T power off retentive area  | 640  | -           |
|                   | C  | FD8205 | Start tag of C power off retentive area  | 320  | C320~C639   |
|                   | S  | FD8206 | Start tag of S power off retentive area  | 512  | S512~S1023  |
| <b>XC3 series</b> | D  | FD8202 | Start tag of D power off retentive area  | 4000 | D4000~D7999 |
|                   | M  | FD8203 | Start tag of M power off retentive area  | 3000 | M3000~M7999 |
|                   | T  | FD8204 | Start tag of T power off retentive area  | 640  | -           |
|                   | C  | FD8205 | Start tag of C power off retentive area  | 320  | C320~C639   |
|                   | S  | FD8206 | Start tag of S power off retentive area  | 512  | S512~S1023  |
|                   | ED | FD8207 | Start tag of ED power off retentive area | 0    | ED0~ED16383 |
| <b>XC5 series</b> | D  | FD8202 | Start tag of D power off retentive area  | 4000 | D4000~D7999 |
|                   | M  | FD8203 | Start tag of M power off retentive area  | 4000 | M4000~M7999 |
|                   | T  | FD8204 | Start tag of T power off retentive area  | 640  | -           |
|                   | C  | FD8205 | Start tag of C power off retentive area  | 320  | C320~C639   |
|                   | S  | FD8206 | Start tag of S power off retentive area  | 512  | S512~S1023  |
|                   | ED | FD8207 | Start tag of ED power off retentive area | 0    | ED0~ED36863 |
| <b>XCM</b>        | D  | FD8202 | Start tag of D power off                 | 4000 | D4000~D4999 |

| series |    |        | retentive area                           |      |             |
|--------|----|--------|--|------|-------------|
|        | M  | FD8203 | Start tag of M power off retentive area  | 3000 | M3000~M7999 |
|        | T  | FD8204 | Start tag of T power off retentive area  | 640  | -           |
|        | C  | FD8205 | Start tag of C power off retentive area  | 320  | C320~C639   |
|        | S  | FD8206 | Start tag of S power off retentive area  | 512  | S512~S1023  |
|        | ED | FD8207 | Start tag of ED power off retentive area | 0    | ED0~ED36863 |

## 6、Communication

|      | ID     | Function                          | Initial | Description   |
|------|--------|-----------------------------------|---------|---|
| COM1 | FD8210 | Communicate Mode (station number) | 1       | 255 (FF) is free mode, 1~254 is modbus station number           |
|      | FD8211 | Communicate format                | 8710    | Baud rate, Data bit, stop bit, parity                           |
|      | FD8212 | Judgment time of ASC timeout      | 3       | Unit ms, if set to be 0, it means no timeout waiting            |
|      | FD8213 | Judgment time of reply timeout    | 300     | Unit ms, if set to be 0, it means no timeout waiting            |
|      | FD8214 | Start ASC                         | 0       | High 8 bits invalid   |
|      | FD8215 | End ASC                           | 0       | High 8 bits invalid   |
|      | FD8216 | Free format setting               | 0       | 8/16 bits buffer; With/without start bit, With/without stop bit |
| COM2 | FD8220 | Communicate Mode (station number) | 8710    | 255 (FF) is free mode, 1~254 is modbus station number           |
|      | FD8221 | Communicate format                | 3       | Baud rate, Data bit, stop bit, parity                           |
|      | FD8222 | Judgment time of ASC timeout      | 300     | Unit ms, if set to be 0, it means no timeout waiting            |
|      | FD8223 | Judgment time of reply timeout    | 0       | Unit ms, if set to be 0, it means no timeout waiting            |
|      | FD8224 | Start ASC                         | 0       | High 8 bits invalid   |
|      | FD8225 | End ASC                           | 0       | High 8 bits invalid   |
|      | FD8226 | Free format setting               | 8710    | 8/16 bits buffer; With/without start bit, With/without stop bit |

|      |        |                                      |      |   |
|------|--------|--------------------------------------|------|---|
| COM3 | FD8230 | Communicate Mode<br>(station number) | 8710 | 255 (FF) is free mode,<br>1~254 is modbus station number              |
|      | FD8231 | Communicate format                   | 3    | Baud rate, Data bit, stop bit,<br>parity                              |
|      | FD8232 | Judgment time of ASC<br>timeout      | 300  | Unit ms, if set to be 0, it means no<br>timeout waiting               |
|      | FD8233 | Judgment time of reply<br>timeout    | 0    | Unit ms, if set to be 0, it means no<br>timeout waiting               |
|      | FD8234 | Start ASC                            | 0    | High 8 bits invalid   |
|      | FD8235 | End ASC                              | 0    | High 8 bits invalid   |
|      | FD8236 | Free format setting                  | 8710 | 8/16 bits buffer;<br>With/without start bit,<br>With/without stop bit |

---

※: If you change special FLASH memory, it will take into effect after restart the PLC

---

---

## Appendix 2 Special function version requirements

---

Some special functions have version requirements for PLC hardware and software. Please pay attention to the following table:

| Function  | Hardware version | Software version                  |
|---|------------------|-----------------------------------|
| DFMOV fill move 32-bit instruction                      | ≧ V3.0           | ≧ V3.0                            |
| EMOV float move   | ≧ V3.3           | ≧ V3.3                            |
| GRY and GBIN gray code and binary switching             | ≧ V3.3           | ≧ V3.3                            |
| Anti-trigonometric functions                            | ≧ V3.0           | ≧ V3.0                            |
| Read and write RTC                                      | ≧ V2.51          | ≧ V3.0                            |
| Read and write high speed counter                       | ≧ V3.1c          | ≧ V3.0                            |
| High speed counter interruption                         | ≧ V3.1c          | ≧ V3.0                            |
| Pulse output PTO、PTOA、PSTOP、PTF                         | ≧ V3.3           | ≧ V3.3                            |
| RCVST serial port release for free format communication | ≧ V3.1e          | ≧ V3.1f                           |
| Read precise timer                                      | ≧ V3.0e          | ≧ V3.0                            |
| Stop precise timer                                      | ≧ V3.0e          | ≧ V3.0                            |
| C function block  | ≧ V3.0c          | ≧ V3.0                            |
| PID function  | ≧ V3.0           | ≧ V3.0                            |
| Sequence block  | ≧ V3.2           | ≧ V3.1h                           |
| Connect to T-BOX, XC-TBOX-BD                            | ≧ V3.0g          | V3.0f or<br>≧ V3.3f <sup>※1</sup> |
| Connect to G-BOX  | ≧ V3.0i          | ≧ V3.0                            |
| Connect to XC-SD-BD                                     | ≧ V3.2           | ≧ V3.2                            |
| Read and write XC-E6TCA-P, XC-E2AD2PT3DA, XC-E2AD2PT2DA | ≧ V3.1f          | ≧ V3.1b                           |
| ED extension register                                   | ≧ V3.0           | ≧ V3.0                            |

---

※1: Old version of T-BOX, T-BOX-BD: software v3.0f; new version of T-BOX, T-BOX-BD (made after Oct, 2010): software v3.3f and higher.

---



|                 |  |   |   |   |   |   |   |        |
|-----------------|--|---|---|---|---|---|---|--------|
| OR >=           | OR activate if(S1) >= (S2)                         | • | • | • | • | • | • | 4-4-3  |
| Data move       |  |   |   |   |   |   |   |        |
| CMP             | Data compare                                       | • | • | • | • | • | • | 4-5-1  |
| ZCP             | Data zone compare                                  | • | • | • | • | • | • | 4-5-2  |
| MOV             | Move   | • | • | • | • | • | • | 4-5-3  |
| BMOV            | Block move   | • | • | • | • | • | • | 4-5-4  |
| PMOV            | Block move   | • | • | • | • | • | • | 4-5-5  |
| FMOV            | Repeat move  | • | • | • | • | • | • | 4-5-6  |
| EMOV            | Float move   |   | • | • | • | • | • | 4-5-7  |
| FWRT            | FlashROM Written                                   | • | • | • | • | • | • | 4-5-8  |
| MSET            | Zone set   | • | • | • | • | • | • | 4-5-9  |
| ZRST            | Zone reset   | • | • | • | • | • | • | 4-5-10 |
| SWAP            | The high bytes and low bytes exchange              | • | • | • | • | • | • | 4-5-11 |
| XCH             | Data exchange                                      | • | • | • | • | • | • | 4-5-12 |
| Data operations |  |   |   |   |   |   |   |        |
| ADD             | addition   | • | • | • | • | • | • | 4-6-1  |
| SUB             | subtraction  | • | • | • | • | • | • | 4-6-2  |
| MUL             | multiplication                                     | • | • | • | • | • | • | 4-6-3  |
| DIV             | division   | • | • | • | • | • | • | 4-6-4  |
| INC             | Increment  | • | • | • | • | • | • | 4-6-5  |
| DEC             | decrement  | • | • | • | • | • | • | 4-6-5  |
| MEAN            | mean   | • | • | • | • | • | • | 4-6-6  |
| WAND            | Word and   | • | • | • | • | • | • | 4-6-6  |
| WOR             | Word or  | • | • | • | • | • | • | 4-6-6  |
| WXOR            | Word exclusive or                                  | • | • | • | • | • | • | 4-6-7  |
| CML             | Complement   | • | • | • | • | • | • | 4-6-8  |
| NEG             | Negative   | • | • | • | • | • | • | 4-6-9  |
| Data shift      |  |   |   |   |   |   |   |        |
| SHL             | Arithmetic shift left                              |   | • | • | • | • | • | 4-7-1  |
| SHR             | Arithmetic shift right                             |   | • | • | • | • | • | 4-7-1  |
| LSL             | Logic shift left                                   |   | • | • | • | • | • | 4-7-2  |
| LSR             | Logic shift right                                  |   | • | • | • | • | • | 4-7-2  |
| ROL             | Rotation shift left                                |   | • | • | • | • | • | 4-7-3  |
| ROR             | Rotation shift right                               |   | • | • | • | • | • | 4-7-3  |
| SFTL            | Bit shift left                                     |   | • | • | • | • | • | 4-7-4  |
| SFTR            | Bit shift right                                    |   | • | • | • | • | • | 4-7-5  |
| WSFL            | Word shift left                                    |   | • | • | • | • | • | 4-7-6  |
| WSFR            | Word shift right                                   |   | • | • | • | • | • | 4-7-7  |
| Data convert    |  |   |   |   |   |   |   |        |
| WTD             | Single word integer convert to double word integer |   | • | • | • | • | • | 4-8-1  |

|                    |  |  |   |   |   |   |   |        |
|--------------------|--|--|---|---|---|---|---|--------|
| FLT                | 16 bits integer convert to float                     |  | • | • | • | • | • | 4-8-2  |
| DFLT               | 32 bits integer convert to float                     |  | • | • | • | • | • | 4-8-2  |
| FLTD               | 64 bits integer convert to float                     |  | • | • | • | • | • | 4-8-2  |
| INT                | Float convert to integer                             |  | • | • | • | • | • | 4-8-3  |
| BIN                | BCD convert to binary                                |  | • | • | • | • | • | 4-8-4  |
| BCD                | Binary convert to BCD                                |  | • | • | • | • | • | 4-8-5  |
| ASCI               | Hex convert to ASCII                                 |  | • | • | • | • | • | 4-8-6  |
| HEX                | ASCII convert to Hex                                 |  | • | • | • | • | • | 4-8-7  |
| DECO               | Coding   |  | • | • | • | • | • | 4-8-8  |
| ENCO               | High bit coding                                      |  | • | • | • | • | • | 4-8-9  |
| ENCOL              | Low bit coding                                       |  | • | • | • | • | • | 4-8-10 |
| GRY                | Binary to gray code                                  |  | • | • | • | • | • | 4-8-11 |
| GBIN               | Gray code to binary                                  |  | • | • | • | • | • | 4-8-12 |
| Float operation    |  |  |   |   |   |   |   |        |
| ECMP               | Float compare  |  | • | • | • | • | • | 4-9-1  |
| EZCP               | Float zone compare                                   |  | • | • | • | • | • | 4-9-2  |
| EADD               | Float addition                                       |  | • | • | • | • | • | 4-9-3  |
| ESUB               | Float subtraction                                    |  | • | • | • | • | • | 4-9-4  |
| EMUL               | Float multiplication                                 |  | • | • | • | • | • | 4-9-5  |
| EDIV               | Float division                                       |  | • | • | • | • | • | 4-9-6  |
| ESQR               | Float square root                                    |  | • | • | • | • | • | 4-9-7  |
| SIN                | Sine   |  | • | • | • | • | • | 4-9-8  |
| COS                | Cosine   |  | • | • | • | • | • | 4-9-9  |
| TAN                | tangent  |  | • | • | • | • | • | 4-9-10 |
| ASIN               | Float arcsin   |  | • | • | • | • | • | 4-9-11 |
| ACOS               | Float arccos   |  | • | • | • | • | • | 4-9-12 |
| ATAN               | Float arctan   |  | • | • | • | • | • | 4-9-13 |
| Clock              |  |  |   |   |   |   |   |        |
| TRD                | Read RTC data  |  | • | • | • | • | • | 4-10-1 |
| TWR                | Set RTC data   |  | • | • | • | • | • | 4-10-2 |
| High speed counter |  |  |   |   |   |   |   |        |
| HSCR               | Read high speed counter value                        |  | • | • | • | • | • | 5-6-1  |
| HSCW               | Write high speed counter value                       |  | • | • | • | • | • | 5-6-2  |
| Pulse output       |  |  |   |   |   |   |   |        |
| PLSY               | Single segment no accelerate/decelerate pulse output |  | • | • | • | • | • | 6-2-1  |
| PLSF               | Changeable frequency pulse output                    |  | • | • | • | • | • | 6-2-2  |
| PLSR               | Relative position multi-segment pulse                |  | • | • | • | • | • | 6-2-3  |

|                           |  |  |   |   |   |   |   |   |        |
|---------------------------|--|--|---|---|---|---|---|---|--------|
|                           | control  |  |   |   |   |   |   |   |        |
| PLSNEXT/<br>PLSNT         | change the pulse segment                       |  | • | • | • | • | • | • | 6-2-4  |
| STOP                      | Pulse stop                                     |  | • | • | • | • | • | • | 6-2-5  |
| PLSMV                     | Save the pulse number in the register          |  | • | • | • | • | • | • | 6-2-6  |
| ZRN                       | Origin return                                  |  | • | • | • | • | • | • | 6-2-7  |
| DRVI                      | Relative position                              |  | • | • | • | • | • | • | 6-2-8  |
| DRVA                      | Absolute position                              |  | • | • | • | • | • | • | 6-2-9  |
| PLSA                      | Absolute position multi-segment pulse control  |  | • | • | • | • | • | • | 6-2-10 |
| PTO                       | Relative position multi-segment pulse control  |  |   | • | • | • | • | • | 6-2-11 |
| PTOA                      | Absolute position multi-segment pulse control  |  |   | • | • | • | • | • | 6-2-12 |
| PSTOP                     | Pulse stop                                     |  |   | • | • | • | • | • | 6-2-13 |
| PTF                       | Variable frequency single-segment pulse output |  |   | • | • | • | • | • | 6-2-14 |
| MODBUS communication      |  |  |   |   |   |   |   |   |        |
| COLR                      | MODBUS coil read                               |  | • | • | • | • | • | • | 7-2-3  |
| INPR                      | MODBUS input coil read                         |  | • | • | • | • | • | • | 7-2-3  |
| COLW                      | MODBUS single coil write                       |  | • | • | • | • | • | • | 7-2-3  |
| MCLW                      | MODBUS multi coil write                        |  | • | • | • | • | • | • | 7-2-3  |
| REGR                      | MODBUS register read                           |  | • | • | • | • | • | • | 7-2-3  |
| INRR                      | MODBUS input register write                    |  | • | • | • | • | • | • | 7-2-3  |
| REGW                      | MODBUS single register write                   |  | • | • | • | • | • | • | 7-2-3  |
| MRGW                      | MODBUS multi register write                    |  | • | • | • | • | • | • | 7-2-3  |
| Free format communication |  |  |   |   |   |   |   |   |        |
| SEND                      | Free format data send                          |  | • | • | • | • | • | • | 7-3-2  |
| RCV                       | Free format data receive                       |  | • | • | • | • | • | • | 7-3-2  |
| RCVST                     | Release serial port                            |  | • | • | • | • | • | • | 7-3-2  |
| CAN-bus communication     |  |  |   |   |   |   |   |   |        |
| CCOLR                     | CANBUS coil read                               |  |   |   | • |   |   | • | 7-4-4  |
| CCOLW                     | CANBUS coil write                              |  |   |   | • |   |   | • | 7-4-4  |
| CREGR                     | CANBUS register read                           |  |   |   | • |   |   | • | 7-4-4  |
| CREGW                     | CANBUS register write                          |  |   |   | • |   |   | • | 7-4-4  |
| Other                     |  |  |   |   |   |   |   |   |        |
| PID                       | PID control                                    |  | • | • | • | • | • | • | 8-2    |

|                    |  |  |   |   |   |   |   |        |
|--------------------|--|--|---|---|---|---|---|--------|
| NAME_C             | Call the C function                                |  | ● | ● | ● | ● | ● | 9-2    |
| SBSTOP             | Pause BLOCK running                                |  | ● | ● | ● | ● | ● | 10-6   |
| SBGOON             | Continue running BLOCK                             |  | ● | ● | ● | ● | ● | 10-6   |
| WAIT               | Wait   |  | ● | ● | ● | ● | ● | 10-3-4 |
| PWM                | Pulse output with certain frequency and duty ratio |  | ● | ● | ● | ● | ● | 11-1   |
| FRQM               | Frequency test                                     |  | ● | ● | ● | ● |   | 11-2   |
| STR                | Precise timer                                      |  | ● | ● | ● | ● | ● | 11-3   |
| STRR               | Read precise timer register                        |  | ● | ● | ● | ● | ● | 11-3   |
| STRS               | Stop the precise timer                             |  | ● | ● | ● | ● | ● | 11-3   |
| EI                 | Interruption enable                                |  | ● | ● | ● | ● | ● | 11-4   |
| DI                 | Interruption disable                               |  | ● | ● | ● | ● | ● | 11-4   |
| IRET               | Interruption return                                |  | ● | ● | ● | ● | ● | 11-4   |
| Read write module  |  |  |   |   |   |   |   |        |
| FROM <sup>※1</sup> | Read the module                                    |  | ● | ● | ● | ● | ● |        |
| TO <sup>※2</sup>   | Write the module                                   |  | ● | ● | ● | ● | ● |        |

※1: Please refer to XC series expansion module manual.

※2: “●” means this model supports the present instruction.

## Appendix 4 PLC resource conflict list

Some functions will occupy the same resource of PLC, especially high speed counter, precise timer, pulse output and PWM and frequency test. Please do not use these functions at the same time.

|                                |      | High speed counter |      |                  | Pulse output | PWM | Frequency test |
|--------------------------------|------|--------------------|------|------------------|--------------|-----|----------------|
| <b>XC2-14/16/24/32/48/60</b>   |      |                    |      |                  |              |     |                |
|                                | T618 | -                  | -    | -                | Y0           | Y0  | -              |
|                                | T606 | C604               | C622 | C632             | -            | -   | -              |
|                                | T610 | C600               | C620 | C630             | -            | -   | -              |
|                                | T614 | -                  | -    | -                | Y1           | Y1  | -              |
|                                | T604 | C606               | -    | -                | -            | -   | X6             |
|                                | T616 | -                  | -    | -                | Y0           | -   | -              |
|                                | T608 | C602               | -    | -                | -            | -   | X1             |
|                                | T602 | C608               | -    | C630(24-segment) | -            | -   | X7             |
|                                | T612 | -                  | -    | -                | Y1           | -   | -              |
| <b>XC3-14</b>                  |      |                    |      |                  |              |     |                |
|                                | T618 | -                  |      |                  | Y0           | Y0  | -              |
|                                | T614 | C600               | C620 | C630             | -            | -   | -              |
|                                | T604 | C606               | -    | -                | -            | -   | -              |
|                                | T610 | -                  | -    | -                | Y1           | Y1  | -              |
|                                | T612 | C602               | -    | -                | -            | -   | X2             |
|                                | T616 | -                  | -    | -                | Y0           | -   | -              |
|                                | T606 | C604               | -    | -                | -            | -   | X3             |
|                                | T608 | -                  | -    | -                | Y1           | -   | -              |
| <b>XC3-24/32/42, XC5-48/60</b> |      |                    |      |                  |              |     |                |
|                                | T606 | -                  | -    | -                | Y1           | Y1  | -              |
|                                | T618 | -                  | -    | -                | Y0           | Y0  | -              |
|                                | T610 | C604               | C622 | C632             | -            | -   | -              |
|                                | T614 | C600               | C620 | C630             | -            | -   | -              |
|                                | T604 | C606               | C624 | C634             | -            | -   | -              |
|                                | T608 | -                  | -    | -                | Y1           | -   | -              |
|                                | T616 | -                  | -    | -                | Y0           | -   | -              |
|                                | T612 | C602               | -    | -                | -            | -   | X1             |
|                                | T602 | C608               | -    | C630(24-segment) | -            | -   | X11            |
|                                | T600 | -                  | -    | -                | -            | -   | X12            |
| <b>XC3-48/60</b>               |      |                    |      |                  |              |     |                |
|                                | -    | -                  | -    | -                | -            | -   | -              |

|                            |      |                      |                      |    |    |    |
|----------------------------|------|----------------------|----------------------|----|----|----|
| T618                       | -    | -                    | -                    | Y0 | Y0 | -  |
| T614                       | C600 | C620                 | C630                 | -  | -  | -  |
| T604                       | C602 | C622                 | C632                 | -  | -  | -  |
| T610                       | -    | -                    | -                    | Y1 | Y1 | -  |
| T612                       | C604 | -                    | -                    | -  | -  | X4 |
| T616                       | -    | -                    | -                    | Y0 | -  | -  |
| T606                       | C606 | -                    | -                    | -  | -  | X5 |
| T600                       | -    | -                    | C630(24-segment)     | -  | -  | -  |
| T608                       | -    | -                    | -                    | Y1 | -  | -  |
| <b>XC3-19AR-E</b>          |      |                      |                      |    |    |    |
| T602                       | -    | -                    | -                    | -  | -  | -  |
| T618                       | -    | -                    | -                    | Y0 | Y0 | -  |
| T614                       | C600 | C620                 | C630                 | -  | -  | -  |
| T604                       | C602 | C622                 | C632                 | -  | -  | -  |
| T610                       | -    | -                    | -                    | -  | -  | -  |
| T612                       | C604 | -                    | -                    | -  | -  | X4 |
| T616                       | -    | -                    | -                    | Y0 | -  | -  |
| T606                       | C606 | -                    | -                    | -  | -  | X5 |
| T600                       | -    | -                    | C630(24-segment)     | -  | -  | -  |
| T608                       | -    | -                    | -                    | -  | -  | -  |
| <b>XC5-24/32、XCM-24/32</b> |      |                      |                      |    |    |    |
| T614                       | -    | -                    | -                    | Y1 | Y1 | -  |
| T618                       | -    | -                    | -                    | Y0 | Y0 | -  |
| T610                       | -    | -                    | -                    | Y2 | Y2 | -  |
| T606                       | C600 | C620                 | C630                 | -  | -  | -  |
| T602                       | -    | -                    | -                    | Y3 | Y3 | -  |
| T612                       | -    | -                    | -                    | Y1 | -  | -  |
| T616                       | -    | -                    | -                    | Y0 | -  | -  |
| T608                       | -    | -                    | -                    | Y2 | -  | -  |
| T604                       | C602 | -                    | C630(24-segment)     | -  | -  | X3 |
| T600                       | -    | -                    | -                    | Y3 | -  | -  |
| <b>XCM-60</b>              |      |                      |                      |    |    |    |
| T614                       | -    | -                    | -                    | Y1 | Y1 | -  |
| T618                       | -    | -                    | -                    | Y0 | Y0 | -  |
| T610                       | -    | -                    | -                    | Y2 | Y2 | -  |
| T606                       | C600 | C620<br>(24-segment) | C630<br>(24-segment) | -  | -  | X1 |
| T602                       | -    | -                    | -                    | Y3 | Y3 | -  |
| T612                       | -    | -                    | -                    | Y0 | -  | -  |
| T616                       | -    | -                    | -                    | Y1 | -  | -  |
| T608                       | -    | -                    | -                    | Y2 | -  | -  |
| T604                       | C602 | -                    | C630                 | -  | -  | -  |

|                  |      |   |                      |    |    |   |
|------------------|------|---|----------------------|----|----|---|
|                  |      |   | (24-segment)         |    |    |   |
| T600             |      |   |                      | Y3 | -  | - |
|                  | C604 | - | C632<br>(24-segment) |    | -  | - |
|                  | C606 | - | C634<br>(24-segment) |    | -  | - |
|                  |      |   |                      |    |    |   |
| <b>XCC-24/32</b> |      |   |                      |    |    |   |
| T616             | -    | - | -                    | Y4 | Y4 | - |
| T618             | -    | - | -                    | Y0 | Y0 | - |
| T614             | -    | - | -                    | Y1 | Y1 | - |
| T612             | -    | - | -                    | Y2 | Y2 | - |
| T610             | -    | - | -                    | Y3 | Y3 | - |
| T606             | -    | - | -                    | Y4 | -  | - |
| T608             | -    | - | -                    | Y0 | -  | - |
| T604             | -    | - | -                    | Y1 | -  | - |
| T602             | -    | - | -                    | Y2 | -  | - |
| T600             | -    | - | -                    | Y3 | -  | - |
|                  | C600 | - | C630                 |    | -  | - |
|                  | C602 |   | C632                 |    |    |   |
|                  | C604 |   | C634                 |    |    |   |
|                  | C606 |   | C636                 |    |    |   |
|                  | C608 |   | C638                 |    |    |   |

※1: Any two resources in the same row cannot be used at the same time.

※2: For some models, pulse output terminal Y1 cannot be used together with extension BD board.



**XINJE Electric Co., Ltd.**

4th Floor, Building 7th, No.100

Dicui Rd, Wuxi, China

Tel: 86-0510-85134139

Fax: 86-0510-85111290

[www.xinje.com](http://www.xinje.com)

Email: [cheerfiona@gmail.com](mailto:cheerfiona@gmail.com)